

Precision Dial Indicators 810 DIN style

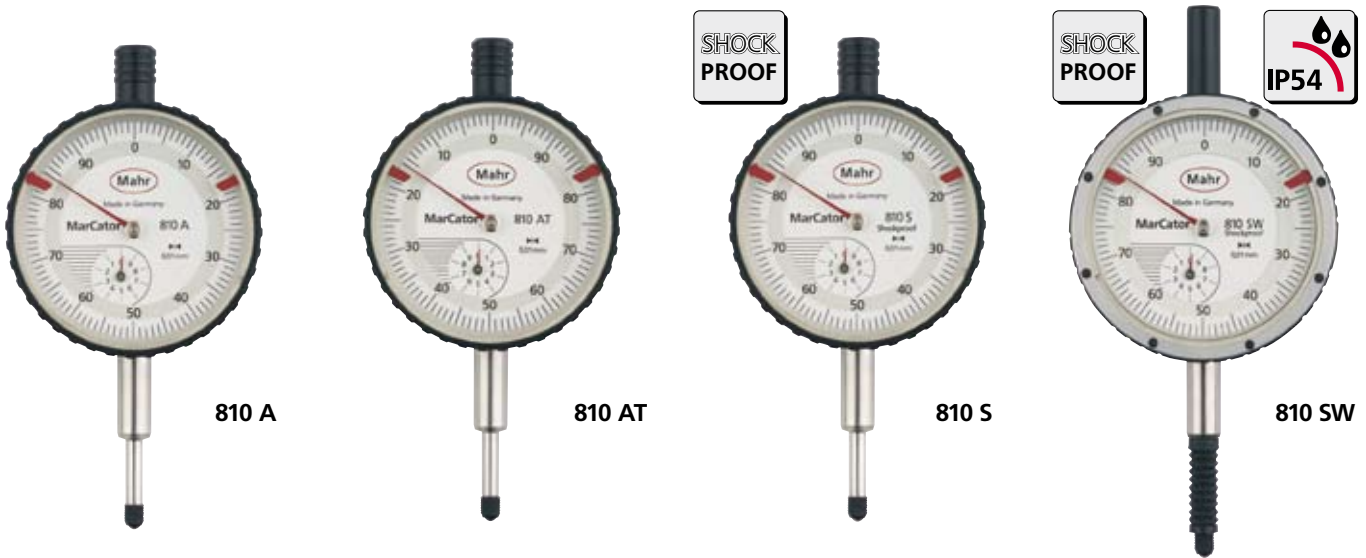

Features

Dial Indicator 810 A

Standard version

- High precision gears and pinions
- Lifter protection cap on the upper end of the measuring spindle
- Adjustable tolerance markers
- Chrome-plated housing

Dial Indicator 810 AT

for depth measurement

- Design features identical to 810 A, with the following exception:
- Scale of the dial face is counter-clockwise

Dial Indicator 810 S

Shockproof

- High precision gears and pinions
- Lifter protection cap on the upper end of the measuring spindle
- Adjustable tolerance markers
- Chrome-plated housing

Dial Indicator 810 SW

Waterproof and oil proof

- Design features identical to 810 S, with the following exceptions:
- Measuring spindle sealed with rubber sleeve, thus preventing contamination by liquids and impurities
 - Hermetically sealed protective measuring spindle cap

All indicators delivered in plastic case

Technical Data

	Range	Readings	Dial face dia.	Overtravel	Mounting shank dia.	Measuring force	Accuracy	Order no.
	mm	mm	mm	mm	mm	N	DIN 878	
810 A	10	0.01	50	0.1	8h6	0.7 - 1.3	●	4311050
810 AT	10	0.01	50	0.1	8h6	0.7 - 1.3	●	4311060
810 S	10	0.01	50	0.1	8h6	0.8 - 1.3	●	4311000
810 SW	10	0.01	50	0.1	8h6	0.9 - 1.5	●	4315000
810 SB	0.8 (±0.4)	0.01	50	9	8h6	0.9	●	4317000
810 SM	1	0.001	50	4	8h6	1.3 - 1.8		4311070
810 SRM	5	0.001	50	0.1	8h6	1.5 - 2		4311080
810 AZ	.400"	.0005"	2"	.004"	8h6	0.9 - 1.5		4311900

Accessories

	Order no.		Order no.
Adapter Bush for adapting mounting shank 8h6 mm to inch bore .375"	940	4310103	
Splash Guard Cover for bezel dia. 58 mm	955	4373020	
Mounting Lug			
Bore perpendicular to mounting shank	961	4375010	
Bore parallel to mounting shank	962	4375011	

Precision Dial Indicators 810 DIN style



810 SB



810 SM

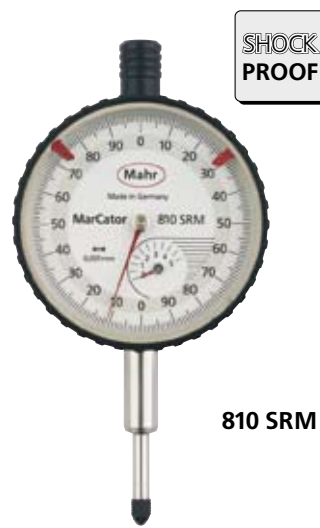

810 SRM

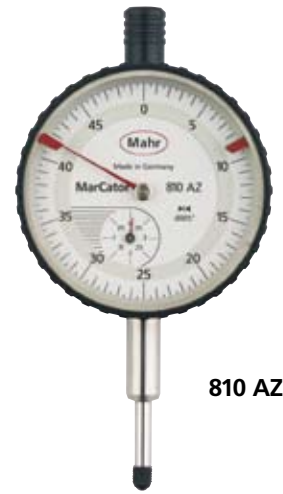

810 AZ

Features

Dial Indicator 810 SB with limited measuring range

Design features identical to 810 S, with the following exceptions:

- Limited measuring range (0.8 mm) for error-free readings
- Large overtravel (approx. 9 mm) for easier insertion of test items in measuring devices
- Hermetically sealed protective measuring spindle cap

Dial Indicator 810 SM Shockproof with reading 0.001 mm

- Precise mechanism with a combined gear lever transmission
- High accuracy with a minimum span of error
- Lifter protection cap on the upper end of the measuring spindle
- Adjustable tolerance markers
- Chrome-plated housing

Dial Indicator 810 SRM Shockproof with reading 0.001 mm

- High precision gears and pinions
- Lifter protection cap on the upper end of the measuring spindle
- Adjustable tolerance markers
- Chrome-plated housing

Dial Indicator 810 AZ Inch version

Design features are identical to 810 A, with the following exception:

- The scope of supply includes an Adapter Bush 940 for adapting mounting shank 8h6 mm to inch bore .375"

Dimensions according to DIN EN ISO 463

mm	a	b	c	d	e	f	g
810 A/AT	∅ 58	23	7.5	52	112	21	16
810 S	∅ 58	23	7.5	52	111.5	22	15
810 SW	∅ 61	24.15	7.9	52	127.6	22	22.1
810 SB	∅ 58	23	7.5	52	120	22	15
810 SM	∅ 58	25	8.5	52	111.5	22	15
810 SRM	∅ 58	23	7.5	52	111.5	22	15
810 AZ	∅ 58	23	7.5	52	111.5	22	15

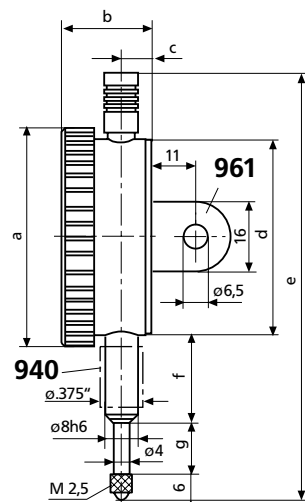

Shown with Mounting Lug

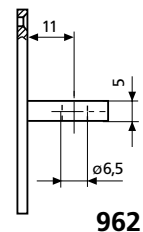

Contact Points and Accessories for Dial Indicators, Dial Comparators and Probes

Standard Contact Points 901

Ball dia. 3 mm

Catalog no.		Order no.
901	with steel ball	4360001
901 H	with carbide ball	4360002
901 R	with ruby ball	4360003

Spherical Contact Points 902 Flat Contact Points 903

902 Steel	902 H Carbide contact face	903 Steel	903 H Carbide tipped
Length mm	Order no.	Order no.	Order no.
4	4360007	—	4360070
6	4360009	—	4360071
8	4360010	4360040	4360072
10	4360011	4360041	4360073
12	4360012	4360042	4360074
15	4360013	4360043	4360075
20	4360014	4360044	4360076
25	4360015	4360045	4360077
30	4360016	4360046	4360300
35	4360017	4360047	4360078
40	4360019	4360049	4360310
45	4360026	4360050	4360303
50	4360018	4360048	4360079
55	4360031		
65	4360035		
75	4360020		
85	4360036		
95	4360029		

Ball Contact Point 906 H

with carbide ball. accuracy ball dia. 0/-6µm

Ball dia. d mm	l mm	Order no.	Ball dia. d mm	l mm	Order no.
1	8.5	4360150	5.5	9	4360161
1.25	8.5	4360151	6	9	4360162
1.5	8.5	4360152	6.35 (1/4")	9	4360163
1.75	8.5	4360153	6.5	10	4360164
2	8.5	4360154	7	10	4360165
2.5	8.5	4360155	7.5	11	4360166
3	8.5	4360156	8	11	4360167
3.5	8.5	4360157	8.5	12	4360168
4	8.5	4360158	9	12	4360169
4.5	8.5	4360159	10	13	4360170
5	9	4360160			

Contact Rollers 909

Concentricity error 3 µm

	Order no.
Cylindrical Roller	909 A 4360220
Radiused Roller, R = 5 mm	909 B 4360221

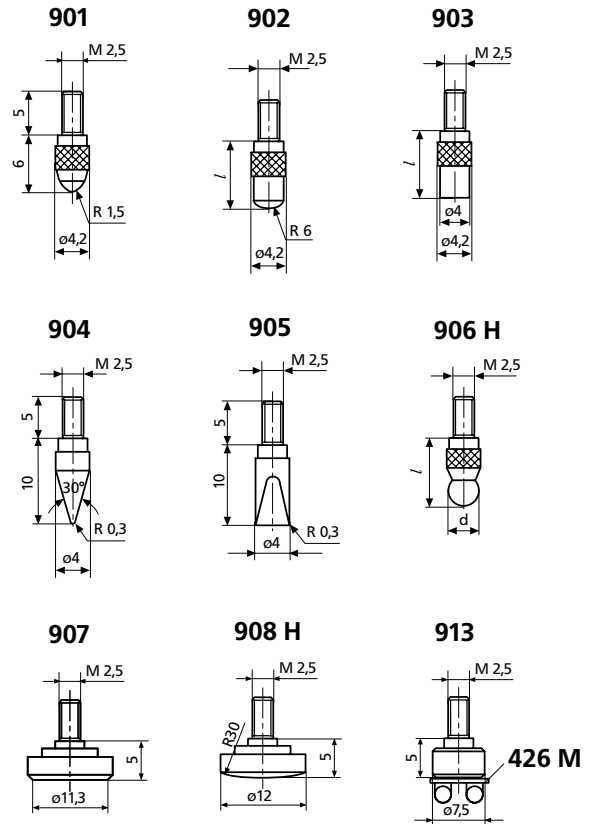

Special Contact Points

	Order no.
Conical Contact Points, Steel	904 4360130
Carbide tipped	904 H 4360131
Wedge Shaped Contact Points, Steel	905 4360140
Carbide tipped	905 H 4360141
Flat Contact Points, Steel, A = 1 cm²	907 4360200
Carbide tipped, dia. 7 mm	907 H 4360201
Spherical Contact Points, Steel	908 4360210
Carbide tipped	908 H 4360211
Flat Contact Point, for mounting Pin Gage Holder 426 M for measuring threads using three-wire method	913 4360400

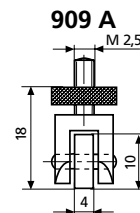

Contact Points and Accessories for Dial Indicators, Dial Comparators and Probes

Measuring Attachment 910 H

	Order no.
with parallel adjustable carbide blades	910 H 4360230

Pin Contact Point 911

dia. 1 mm, flat

Length <i>l</i> mm	Order no.	Length <i>l</i> mm	Order no.
15	4360280	35	4360284
20	4360281	40	4360285
25	4360282	50	4360286
30	4360283		

Pin Contact Point 911 H

	Order no.
Carbide tipped, dia 1 mm, flat	911 H1 4360240
Carbide tipped, dia 1.5 mm, flat	911 H2 4360241

Measuring Spindle Extensions 912

Length <i>l</i> mm	Order no.	Length <i>l</i> mm	Order no.
10	4360250	35	4360254
15	4360251	50	4360255
20	4360252	75	4360256
25	4360253	100	4360257

Special Holder 941

For all types of measuring equipment
 For placing a dial indicator at a certain distance or angle
 Travel of the measuring spindle 3 mm
 Contact Point 901 (interchangeable)

Straight Holder 941 G
 Mounting shank length *l*₁

Angular Holder 941 W

Order no.	<i>l</i> ₂	Order no.	<i>l</i> ₂	Order no.	<i>l</i> ₂
25	4365000	} 53.7	} 49.3	} 34.5	
50	4365001				
75	4365002				
	4365010	} 53.7	} 49.3	} 34.5	
	4365011				
	4365012				
	4365020	} 49.3	} 34.5		
	4365021				
	4365022				
	4365030	} 34.5			
	4365031				
	4365032				

Sensor Level 943

	Order no.
For testing concentricity in bore holes as well as difficult to reach outside diameters To be inserted in a measuring stand with a lifting device Contact Point 901 interchangeable Travel ±1 mm	4367000

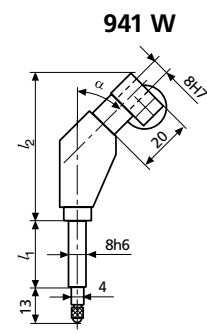
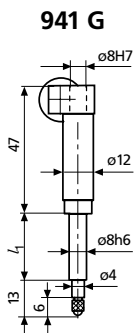
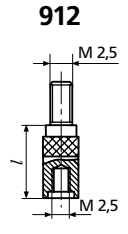
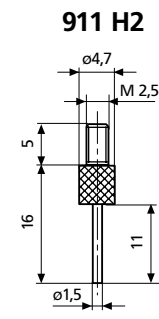
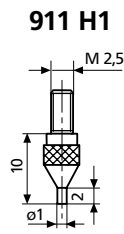
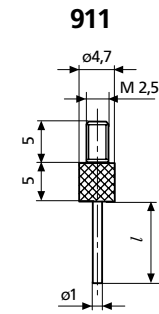
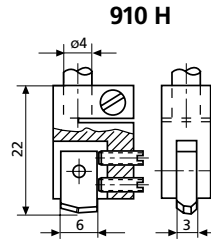

Transmission error with the 941 W
 max. 1%;
 for travel 3 mm = 0.03 mm

