

GESAMTKATALOG GENERAL CATALOGUE CATALOGUE GÉNÉRAL 2020





K KEMMLER®

Ein Unternehmen mit Geschichte und Tradition

KEMMLER® Präzisionswerkzeuge GmbH, das Familienunternehmen aus der baden-württembergischen Stadt Mössingen bei Stuttgart, entwickelt, fertigt und vertreibt innovative und hochpräzise Produkte rund um die Werkzeugmaschine.

Das international tätige Unternehmen wurde 1997 von Fritz Kemmler gegründet und wird mittlerweile in zweiter Generation von Jörg Kemmler geführt.

K KEMMLER®

A company with history and tradition

KEMMLER® Präzisionswerkzeuge GmbH, the family business at Mössingen near Stuttgart in Baden-Württemberg develops, manufactures and distributes innovative and high-precision products around the machine tools.

The international acting company was founded in 1997 by Fritz Kemmler and is now run by the second generation of Jörg Kemmler.

K KEMMLER®

Une entreprise plein d'histoire et de tradition

KEMMLER® Präzisionswerkzeuge GmbH, une entreprise familiale située à Mössingen près de Stuttgart en Bade-Wurtemberg, développe, produit et distribue des produits innovants et précis pour machines outils.

Dès 1997 l'entreprise inaugurée par Fritz Kemmler est active dans le monde entier. Entre-temps ses fils Jörg Kemmler ont pris en charge la direction.

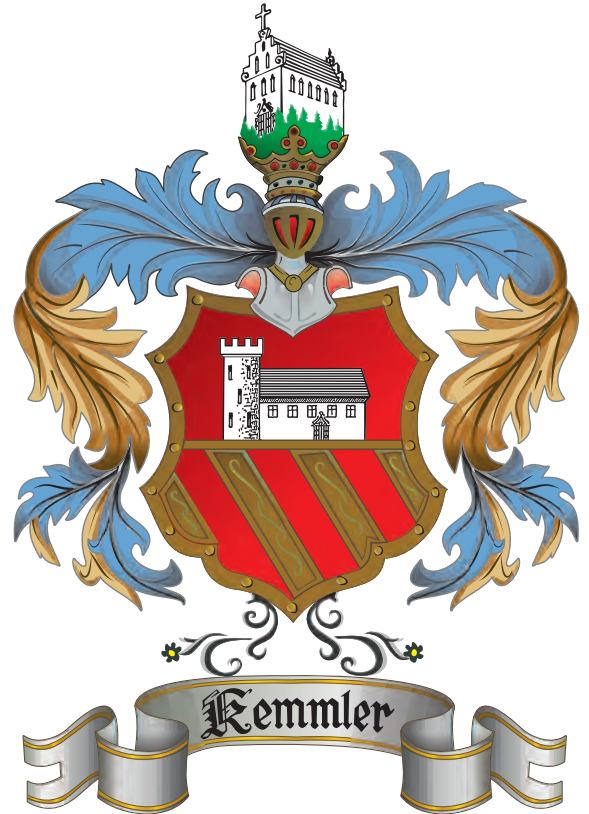

Familienwappen seit 1396

Family crest since 1396

Blason familial dès 1396

<p>Werkzeugaufnahmen DIN 69871 AD/B Toolholders DIN 69871 AD/B Porte-outils DIN 69871 AD/B</p>	1
<p>Werkzeugaufnahmen JIS B 6339 (MAS 403 BT) AD/B Toolholders JIS B 6339 (MAS 403 BT) AD/B Porte-outils JIS B 6339 (MAS 403 BT) AD/B</p>	2
<p>Werkzeugaufnahmen mit Plananlage Toolholders Dual contact Porte-outils Contact direct</p>	3
<p>Werkzeugaufnahmen DIN 2080 Toolholders DIN 2080 Porte-outils DIN 2080</p>	4
<p>Werkzeugaufnahmen DIN 69893 / ISO 12164 (HSK) Toolholders DIN 69893 / ISO 12164 (HSK) Porte-outils DIN 69893 / ISO 12164 (HSK)</p>	5
<p>Werkzeugaufnahmen mit Polygonalschaft ISO 26623 Toolholders with polygonal shank ISO 26623 Porte-outils à queue polygonale ISO 26623</p>	6
<p>Statische u. angetriebene Werkzeuge für CNC-Drehmaschinen Static and power-driven tools for CNC lathes and machining centers porte-outils statiques ou rotatifs pour tours CN</p>	7
<p>Werkzeugaufnahmen MK DIN 228-1 A und DIN 228-1 B Toolholders MT DIN 228-1 A and DIN 228-1 B Porte-outils CM DIN 228-1 A et DIN 228-1 B</p>	8
<p>Spannzangen Collets Pinces</p>	9
<p>Zubehör · Anzugsbolzen Accessories · Pull studs Accessoires · Tirettes</p>	10
<p>Präzisionsschraubstöcke Precision vices Etaux de précision</p>	11
<p>Messtechnik Measuring technique Métrologie</p>	12
<p>Schneidwerkzeuge Cutting tools Outils de coupant</p>	13
<p>Technische Daten Technical data Données techniques</p>	14



KEMMLER®

Fertigung Werkzeughalter

Vom Schmiederohling bis hin zum Endprodukt erfolgen alle Bearbeitungsprozesse unter einem Dach. Nur so kann die 100% **KEMMLER®** Qualität erreicht werden.

Mit modernstem Maschinenpark der jüngsten Generation und sehr hohem Automatisierungsgrad bei großer Fertigungstiefe werden mehr als 40.000 Werkzeughalter im Monat produziert.

KEMMLER®

Toolholder production

*From the forging blank to the final product all working processes take place under the same roof. Just this way the 100% **KEMMLER®** quality can be achieved.*

With modern machinery of the latest generation and a very high degree of automation in a large vertical range of manufacture more than 40.000 toolholders are produced every month.

KEMMLER®

Fabrication de porte-outils

De l'ébauche de forge au produit fini tous les processus d'usinage ont lieu sous le même toit. Seulement ainsi la qualité **KEMMLER®** de 100% peut être obtenue.

Avec des machines modernes de la dernière génération et de très haut degré d'automatisation dans une large portée verticale de fabrication plus de 40.000 porte-outils sont produits par mois.

Schmieden

Forging

Forger



Fräsen und Drehen

Milling and Turning

Fraisage et Tournasage

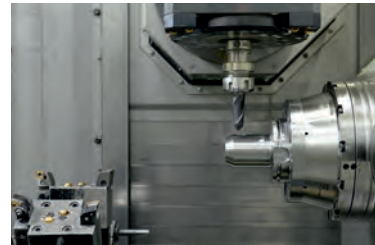
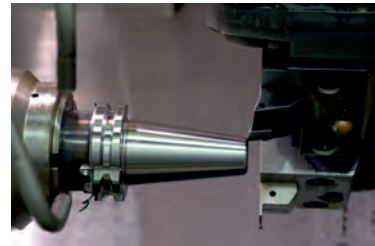
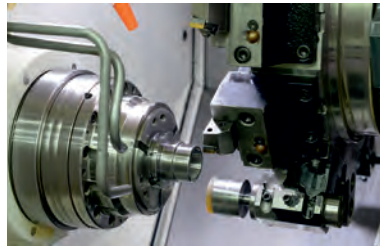
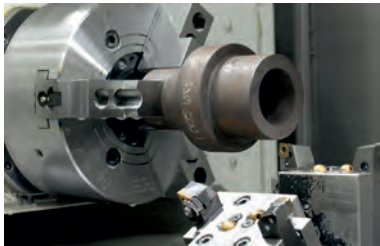

Schleifen

Grinding

Affûtage

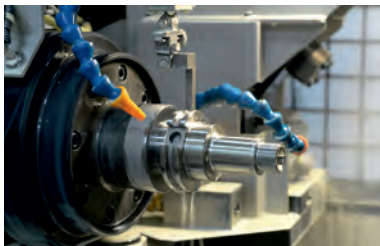

Messen und Auswuchten

Measuring and Balancing

Métrie et Équilibrage

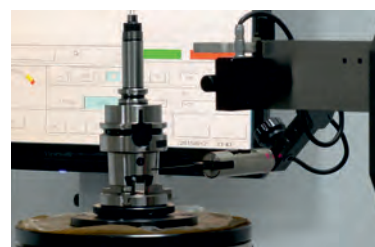
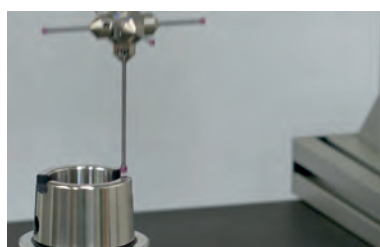
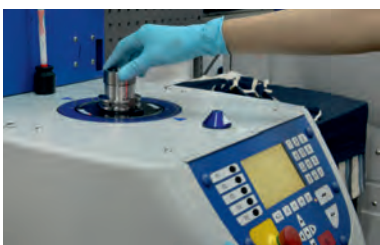



KEMMLER®

Präzision in Perfektion

KEMMLER® Präzisionswerkzeuge ist Ihr kompetenter Partner und Lieferant für qualitativ hochwertige Produkte und fertigt auf Werkzeugmaschinen der jüngsten Generation. Als Hersteller von Werkzeugaufnahmen hat sich das mehrsprachige Unternehmen aufgrund hoher Innovationsfreude und einem überdurchschnittlichen Qualitätsniveau vor Jahren am nationalen und internationalen Markt etabliert.

Der Vertrieb der Produkte erfolgt über die führenden Handelshäuser, Werkzeughersteller, namhaften Erstausrüster und den einschlägigen Fachhandel.

KEMMLER® steht für höchste Präzision in Perfektion, Zuverlässigkeit sowie Qualität und kann damit seine Produkte in besonders anspruchsvollen Branchen zum Einsatz bringen: Luft- und Raumfahrt, Maschinenbau, Medizintechnik und Automobilindustrie.

KEMMLER®

Precision in perfection

KEMMLER® *Präzisionswerkzeuge is your professional partner and supplier for high quality products and manufactures with machine tools of the latest generation. As a manufacturer of tool holders, the multilingual business has established on the national and international market since years due to high innovation and an above-average quality level.*

The products distribution takes place via leading retail companies, tool manufacturer, original equipment manufacturers and the specialist shops.

KEMMLER® *stands for high-precision in perfection, reliability as well as quality and can thus bring its products to ambitious industries: aerospace, engineering, medical technology and the automotive industry.*

KEMMLER®

Précision en perfection

KEMMLER® Präzisionswerkzeuge est votre partenaire et fournisseur compétent pour des produits de haute qualité fabriqués sur machines innovatrices. En tant que producteur de porte-outils notre entreprise plurilingue s'est établie sur le marché national et international grâce à innovations permanentes et une qualité de haut niveau.

La distribution des produits s'effectue par maisons de commerce, fournisseurs d'outils, OEM connus et le commerce spécialisé.

KEMMLER® garantit haute précision, fiabilité et qualité ce qui permet l'emploi de nos produits dans des branches exigeantes – aéronautique et astronautique, construction de machines, technologie médicale et l'industrie automobile.





First Class® ist ein eingetragenes Warenzeichen der Kemmler Präzisionswerkzeuge GmbH. Ein Gütesiegel das Präzision, Qualität, Zuverlässigkeit und hervorragenden Service symbolisiert.

First Class® is a licenced trade mark of Kemmler Präzisionswerkzeuge GmbH. A grade standing for precision, quality, reliability and top class service.

First Class® est une marque déposée de Kemmler Präzisionswerkzeuge GmbH. Une marque qui représente la précision, qualité, fiabilité et un service extraordinaire.

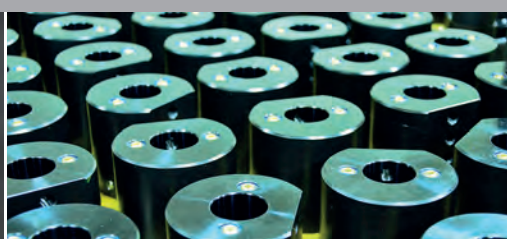



KEMMLER®

Service in Perfektion

KEMMLER® steht nicht nur für Präzision und Qualität bei der Herstellung von Werkzeugaufnahmen, sondern wir wünschen uns vor allem, dass Sie sich wohl fühlen und bieten Ihnen einen erstklassigen Rundum-Service.



SIE BESTELLEN – WIR LIEFERN

KEMMLER® möchte seinen Kunden lange Wartezeiten auf bestellte Ware ersparen. Daher sind rund 98% der **KEMMLER®**-Produkte sofort ab Lager lieferbar. Zudem können Sie als Kunde jederzeit online die Lieferverfügbarkeit abrufen – einfach einloggen, die gewünschte Ware abrufen und bestellen.

KEMMLER®

Service in perfection

KEMMLER® not only stands for precision and quality in the manufacture of toolholders, but our aim is to make you feel comfortable and therefore we offer you a first class all round service.



YOU ORDER – WE DELIVER

KEMMLER® minimizes delivery time for ordered goods. Therefore 98% of all **KEMMLER®**-products are available ex-stock. As a registered customer you can check the availability of the products anytime by online access – just log in, retrieve the desired goods and place the order.

KEMMLER®

Service en perfection

KEMMLER® ne signifie pas seulement précision et qualité au niveau de nos produits. Nous tenons surtout à votre contentement et nous nous efforçons à vous offrir un service complet.



VOUS COMMANDEZ – NOUS EXPÉDIONS

KEMMLER® réduit de longs délais. 98% des produits Kemmler sont en stock. Sur notre site nos clients peuvent vérifier si l'article demandé est disponible. Il faut tout simplement se connecter sur internet et passer la commande.





KEMMLER® WELTWEIT

Als Unternehmen mit internationaler Ausrichtung möchten wir auf die Bedürfnisse unserer Kunden weltweit eingehen: mit persönlicher und kompetenter Fachberatung, der Unterstützung unseres mehrsprachigen Teams und umfassenden, dreisprachigen Produktkatalogen sind wir für Sie da.

Darf es etwas mehr sein?

Sie benötigen spezielle Werkzeuge? Wir stellen uns jeder Herausforderung und fertigen für Sie kurzfristig Sonderwerkzeuge nach Wunsch und liefern innerhalb weniger Wochen.



KEMMLER® WORLDWIDE

As a company with international focus, we want to commit to the needs of our worldwide customers: with personal and competent technical advice, the support of our multi-lingual team and comprehensive, trilingual product catalogues, we are ready to attend you.

Any additional requirements?

You need special tools? We accept every challenge and finish special tools according to your wishes and deliver within few weeks.



KEMMLER® AUTOUR DU MONDE

Comme entreprise à orientation internationale notre objectif est de répondre aux besoins de nos clients dans le monde entier: par une consultation individuelle de notre personnel plurilingue et qualifié et des catalogues détaillés trilingues.

Vous avez un besoin en plus?

Il vous faut des outils spéciaux? Nous acceptons le défi et fabriquons des porte-outils spéciaux sur demande à court terme.



SCHNELLER SERVICE

Wir garantieren Ihnen eine zügige und reibungslose Bestellabwicklung. Wir bearbeiten Ihre Kundenanfragen direkt und verschicken die Ware noch am selben Tag an Sie oder ihren Kunden. Neben einer schnellen Abwicklung erhalten Sie zusätzlich eine Versandbestätigung per E-Mail und können Ihre Bestellung nachverfolgen. Bei Bestellungen aus dem Ausland übernimmt **KEMMLER®** die Zollformalitäten.



RAPID SERVICE

*We guarantee a fast and smooth order processing. We execute your customer inquiries directly and send the goods the same day to you or your customer. In addition to a quick execution you will receive a shipping confirmation by e-mail and you will be able to track your order online. For orders from foreign countries **KEMMLER®** procures the incurring customs formalities.*



SERVICE RAPIDE

Nous garantissons un déroulement vite et sans difficulté. Nous traitons les commandes de vos clients et expédions la marchandise le même jour directement à votre clientèle bien sûr en emballage neutre. La preuve d'expédition vous parvient par mail et vous permet de suivre le transport. **KEMMLER®** s'occupe des formalités douanières si nécessaire.





100% GEPRÜFTE KEMMLER® QUALITÄT

Wer hohe Ansprüche hat, kann sich keine Kompromisse erlauben.

Deshalb fertigt Kemmler leistungsstarke Werkzeuge für optimale Zerspanungsprozesse.

- Sämtliche Aufnahmen werden aus geschmiedetem Stahl gefertigt
- Spezifisch, verzugsarm gehärtet
- Oberflächenhärte HRC 60 ± 2
- Härtetiefe 0,8 mm ± 0,2 mm
- Brüniert und präzisionsgeschliffen
- Kegelwinkeltoleranz < AT 3 nach DIN 7187 und DIN 2080
- Max. Rundlauffehler kleiner als 0,003 mm
- Oberflächenrauigkeit Rz kleiner als 0,5 µ
- Zugfestigkeit im Kern von min. 800 N/mm²
- Standardmäßig dynamisch gewuchtet auf G 6,3 / 15.000 U/min

- Wir liefern Qualität auf höchstem Niveau
- 100 % Qualitätssicherung
- Unschlagbares Preis-Leistungs-Verhältnis
- Katalogwerkzeuge ab Lager lieferbar
- Sonderwerkzeuge kurzfristig innerhalb weniger Wochen
- Qualitätsmanagement nach DIN EN ISO 9001
- Umweltmanagement nach DIN EN ISO 14001
- Qualitätsmanagement nach IATF 16949



K KEMMLER® Quality in perfection

100% CERTIFICATED KEMMLER® QUALITY
Who has high claims cannot afford to make compromises.
Therefore Kemmler manufactures powerful tools for ideal machining processes.

- All holders are made of forged steel
- Specific, low warpage hardened
- Surface hardened HRC 60 ± 2
- Hardening depth 0,8 mm ± 0,2 mm
- Black-finished and precisionground
- Taper angle tolerance < AT 3 according to DIN 7187 and DIN 2080
- Max. runout less than 0,003 mm
- Surface roughness Rz less than 0,5 μ
- Tensile strength in the core of min. 800 N/mm²
- Dynamically balanced by default G 6,3 / 15.000 U/min

- We deliver quality at the highest level
- 100 % quality control
- Unbeatable price-performance ratio
- Catalogue tools available ex-stock
- Special tools shortly available within a few weeks
- Quality management according to DIN EN ISO 9001
- Environment management according to DIN EN ISO 14001
- Quality management according to IATF 16949

K KEMMLER® Qualité en perfection

QUALITÉ KEMMLER® ÉPROUVÉ A 100 %
Ce qui a des exigences élevés ne peut pas accepter des compromis. Kemmler produit des porte-outils performants pour usinage optimal.

- Tous les porte-outils sont fabriqués d'acier forge
- Trempé spécifiquement, déformation minimale
- Rigueur superficielle HRC 60± 2
- Profondeur trempée 0,8 mm ± 2 mm
- Bruni et rectifié précisément
- Tolerance angle du cône < AT 3 selon DIN 7187 et DIN 2080
- Erreur de concentricité max. < 0,003 mm
- Rugosité de la surface Rz <0,5 μ
- Résistance à la traction au moins 800 N/mm²
- Equilibrage dynamique standard G 6,3 / 15.000 t/min

- Nous fournissons une qualité de haut niveau
- 100 % d'assurance qualité
- Rapport prix-performance imbattable
- Porte-outils „standard“ en stock
- Porte-outils spéciaux à court terme
- Contrôle de qualité selon DIN EN ISO 9001
- Management environnemental DIN EN ISO 14001
- Contrôle de qualité selon IATF 16949



IATF 16949
Qualitätsmanagementsystem für die Automobilindustrie

Die Zertifizierung nach IATF 16949 ergänzt unser bereits seit vielen Jahren eingerichtetes Qualitätssicherungssystem nach DIN/ISO 9001/9002. Wir hatten uns zur Zertifizierung entschieden, da für ein Produktionsunternehmen unserer Branche eine Qualitätssicherung nahezu unabdingbare Voraussetzung ist. Hierzu war die IATF 16949 der richtige Maßstab, da sich diese Qualitätssicherungsnorm nicht wie bei den bisherigen Normen auf den Herstellungs- und Prüfungsaspekt der Produkte beschränkt. Sie ist vielmehr ein gesamtunternehmerischer Ansatz, der u.a. das Managementsystem, die Technologie, die Wettbewerbsfähigkeit sowie den Arbeits- und Umweltschutz des Unternehmens einer sehr kritischen Überprüfung und Bewertung unterzieht.

Mit dem Erreichen der IATF 16949 Zertifizierung sehen wir eine Steigerung unserer Leistungsfähigkeit und Verantwortung, die Kundenforderungen qualitätsgerecht und gezielt umzusetzen. Wir überprüfen unsere Kundenorientierung nicht nur, indem wir das Ohr am Kunden haben, sondern auch durch Bewertung der Kundenzufriedenheit und der internen Kunden-Lieferanten-Beziehungen in unserem Unternehmen.

Benchmarking und die Optimierung unserer Prozesse sind Schlüsselfunktionen für weitere Meilensteine unseres Erfolges.



IATF 16949
Quality management system for the automobile industry

The certificate according to IATF 16949 supplements our quality assurance system as described in DIN/ISO 9001/9002, which we established many years ago. Our decision to obtain quality certification is based on the fact that for a producing company independent quality assurance is almost a predetermined prerequisite. In this regard, the IATF 16949 was considered to be the ideal level of measure because the quality assurance standard is not, as in the case of other previously used standards, restricted to manufacturing and examination aspects of our products. In essence, it forms a complete industrial basis including the management system, technology, competitiveness as well as labour and environmental protection, thus providing a critical examination and evaluation.

Our successful acquisition of the certification according to IATF 16949 increases our productivity and potential to implement customer requirements in a qualitative and effective fashion. We review our customer orientation not only by keeping close touch with their needs but also by evaluating customer satisfaction and the relationship between customers and suppliers within our company. Setting benchmarks and optimising internal processes are key indicators for further milestones of our success.



IATF 16949
Système de gestion de qualité pour l'industrie automobile

Ce certificat d'après IATF 16949 complète notre système d'assurance de qualité d'après DIN/ISO 9001/9002 qui a été implanté avant plusieurs ans. Nous avons décidé d'être certifié, parce que pour une entreprise produisant une certification de qualité est presque une supposition inaliénable dans notre branche. L' IATF 16949 a été le bon critère, parce que ce standard d'assurance de qualité ne se limite pas à l'aspect de la production et vérification de nos produits, comme c'était le cas chez des standards précédents. Elle est plutôt un fondement industriel complet, qui inclut le système de gestion, technologie, compétitivité ainsi que protection de l'emploi et de l'environnement, donc fournissant une vérification et évaluation très solide.

Notre acquisition du certificat d'après IATF 16949 élève notre productivité et potentiel de réaliser des demandes de nos clients dans une manière qualitative et effective. Nous vérifions l'orientation de nos clients ne pas seulement par nous aligner sur leurs demandes, mais aussi par évaluer leur satisfaction et la relation entre clients et fournisseurs dans notre société. Benchmarking et l'optimisation de nos procès sont les indicateurs décisifs pour des jalons supplémentaires de notre succès.



Technische Datenblätter, STEP/STL Modelle für die Simulation der NC-Programme und DXF-Zeichnungen zur Erstellung des Einrichteblattes stehen Online zur Verfügung.

Technical data sheets, STEP/STL models for the simulation of NC programs and DXF drawings to create the tooling sheet are online available.

Fiches techniques, STEP/STL modèles techniques pour la simulation de programmes CN et dessins DXF pour créer la feuille d'installation sont disponible online.

Sie können unsere Kataloge entweder direkt im Browser betrachten oder sie auf Ihren PC, Smartphone oder Tablet herunterladen (PDF-Reader notwendig).

You can view our catalogues either directly in the browser or download to your PC, smartphone or tablet (PDF reader required).

Vous pouvez consulter nos catalogues directement dans le navigateur ou télécharger sur votre PC, smartphone ou tablet (lecteur PDF requis).

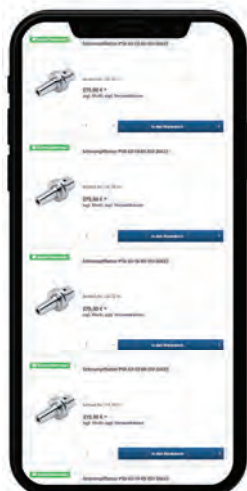

Auf unserer Internetseite können Sie die Lagerverfügbarkeit prüfen - auch auf Mobilgeräten.

On our website you can check the stock availability - also on mobile devices.

Vous pouvez également vérifier la disponibilité de nos produits sur le site Internet - ainsi que sur vos appareils

*WERKZEUGAUFNAHMEN
DIN 69871*

*TOOLHOLDERS
DIN 69871*

*PORTE-OUTILS
DIN 69871*

DIN 69871

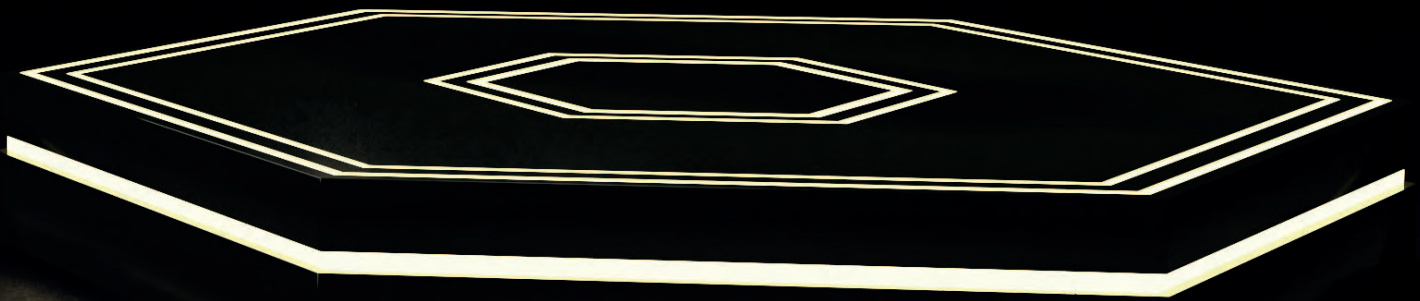
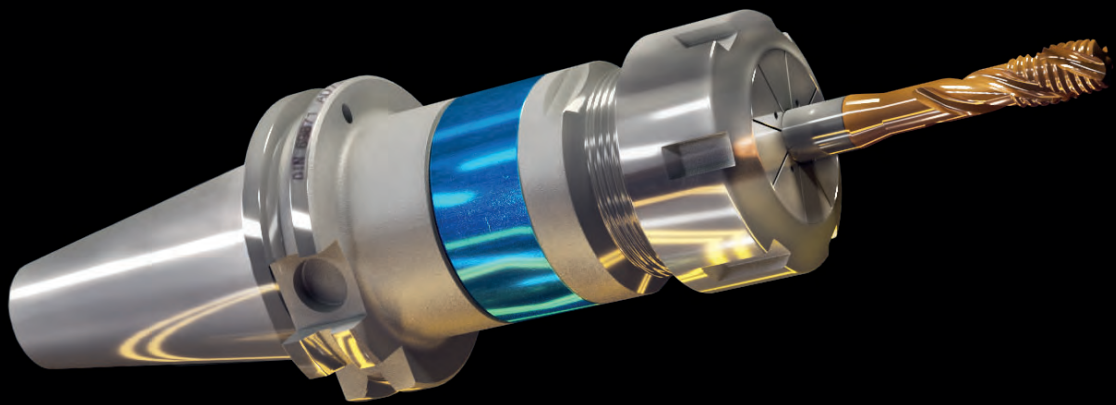

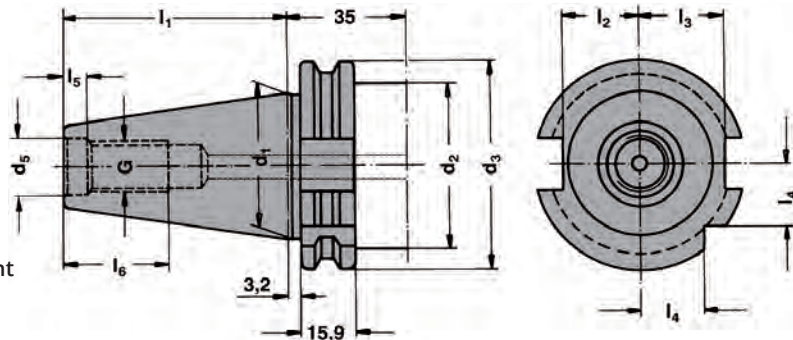
Toolholders DIN 69871
Porte-outils DIN 69871
1
Vorgewuchtet
Pre-balanced
Pré-équilibré
G 6,3 15.000 min⁻¹
G 2,5 *Feinwuchten gegen Aufpreis*
G 2.5 Fine balancing at extra charge
G 2,5 *Equilibrage fin contre un supplément*

SK	d ₁	G	d ₅	d ₂	d ₃	l ₁	l ₂	l ₃	l ₄	l ₅	l ₆	d ₆	e
30	31,75	M12	13	45	50,00	47,80	16,4	19,0	15,0	5,5	24	M4	21
40	44,45	M16	17	50	63,55	68,40	22,8	25,0	18,5	8,2	32	M4	27
50	69,85	M24	25	80	97,50	101,75	35,5	37,7	30,0	11,5	47	M6	42

Mit innerer Kühlmittelzufuhr über den Bund - Form AD/B

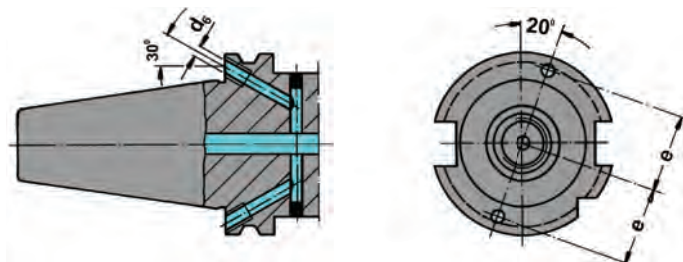
With internal coolant through the collar - form AD/B
Avec arrosage interne par la collerette - forme AD/B
Bei Lieferung mit Gewindestiften verschlossen
Delivery with headless screws in closed position
Livraison en état fermé avec de vis sans tête

Werkstoff: Legierter Einsatzstahl mit einer Zugfestigkeit im Kern von min. 800 N / mm². Einsatzgehärtet HRC 60 ± 2 (HV 700 ± 50), Härtetiefe 0,8 mm ± 0,2 mm, brüniert und präzisionsgeschliffen.

Form AD/B: Lieferung in Ausführung AD, Form B mit lösbaren Gewindestiften verschlossen.

Genauigkeit: Kegelwinkel - Toleranzqualität < AT 3 nach DIN 7187 und DIN 2080.

Material: *Alloyed case-hardened steel, tensile core strength of min. 800 N / mm². Case hardened HRC 60 ± 2 (HV 700 ± 50), hardening depth 0.8 mm ± 0.2 mm, black-finished and precisely grinded.*
Form AD/B: *Delivery in form AD, type B closed with releasable headless screws.*
Accuracy: *Quality of taper < AT 3 according to DIN 7187 and DIN 2080.*
Matière: Acier de cémentation allié. Résistance à la traction dans le noyau de min 800 N / mm². Cémentation à HRC 60 ± 2 (HV 700 ± 50), profondeur de cémentation 0,8 mm ± 0,2 mm, bruni et rectifié précisément.

Forme AD/B: Livraison en forme AD, forme B fermée avec de vis sans tête amovibles.

Précision: Qualité du cône < AT 3 selon DIN 7187 et DIN 2080.



Index
Sommaire



1.05	1.06	1.09	1.11
1.12	1.13	1.14	1.15
1.22	1.23	1.24	1.25
1.27	1.29	1.30	1.31
1.33	1.34	1.35	1.36
1.37	1.38	1.40	1.45
1.46	1.47	1.48	



Collet chucks DIN 6391 for collets DIN 6388 (ISO 10897) OZ-system
Mandrins à pinces DIN 6391 pour pinces DIN 6388 (ISO 10897) système OZ

1



Verwendung:
Zur Aufnahme von Werkzeugen mit Zylinderschaft in Spannzangen.

Application:
For mounting straight-shank tools in collets.

Application:
Pour le serrage d'outils avec queue cylindrique dans des pinces de serrage.

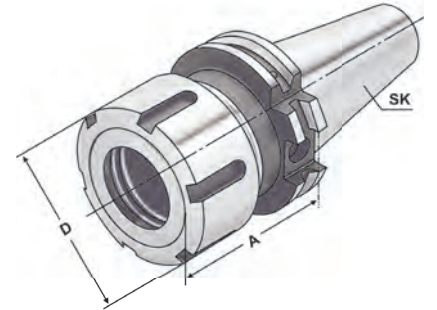

DIN 69871



AD/B

$\nabla \leq 0,003$

G6.3
15.000 min⁻¹



14.04

Bestell-Nr. Order no. Référence	SK	Spannbereich Capacity Capacité	A	D
302.01.16 *	SK 30	2 – 16 (OZ 16)	60	43
302.01.25 *	SK 30	2 – 25 (OZ 25)	80	60
403.01.16	SK 40	2 – 16 (OZ 16)	70	43
403.01.25	SK 40	2 – 25 (OZ 25)	70	60
403.01.32	SK 40	3 – 32 (OZ 32)	90	72
403.01.16.1	SK 40	2 – 16 (OZ 16)	100	43
403.01.25.1	SK 40	2 – 25 (OZ 25)	100	60
503.01.25	SK 50	2 – 25 (OZ 25)	70	60
503.01.32	SK 50	3 – 32 (OZ 32)	80	72
503.01.32.1	SK 50	3 – 32 (OZ 32)	100	72

* DIN 69871 Form AD

* DIN 69871 form AD

* DIN 69871 forme AD

Lieferumfang: Mit kugelgelagerter Spannmutter
Delivery: With ball bearing clamping nut
Livraison: Avec écrou de serrage à roulement à billes

Gewuchtete Ausführung

Balanced type
Type équilibré



Bestell-Nr. Order no. Référence	Abmessung Size Dimension
---------------------------------------	--------------------------------

Wuchten auf G 2,5 von vorgewuchteten Kemmler-Werkzeugen

Balancing at G 2.5 of pre-balanced Kemmler-tools
Équilibrage sur G 2,5 d'outils Kemmler pré-équilibrés

W25 **Ohne Wuchtprotokoll**
Without balancing report
Sans protocole d'équilibrage

W25.2 **Mit Wuchtprotokoll**
With balancing report
Avec protocole d'équilibrage

Wuchten von nicht vorgewuchteten Werkzeugen
Balancing of unbalanced tools
Équilibrage d'outils non-équilibrés

W25.1 **Ohne Wuchtprotokoll**
Without balancing report
Sans protocole d'équilibrage



Collet chucks for collets DIN 6499 (ISO 15488) ER-system
Mandrins à pinces pour pinces DIN 6499 (ISO 15488) système ER



Verwendung:
Zur Aufnahme von Werkzeugen mit
Zylinderschaft in Spannzangen.

Application:
For mounting straight-shank tools in
collets.

Application:
Pour le serrage d'outils avec queue
cylindrique dans des pinces de serrage.

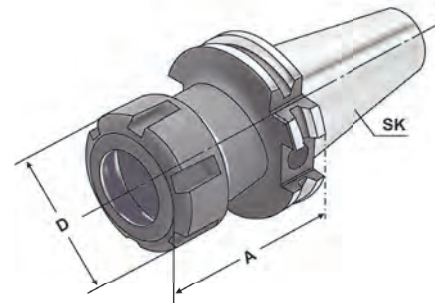

DIN 69871



AD

 $\nabla \leq 0,003$ G6.3
15.000 min⁻¹

Bestell-Nr. Order no. Référence	SK	Spannbereich Capacity Capacité	A	D
302.02.10	SK 30	1 – 10 (ER 16)	70	32
302.02.13	SK 30	2 – 13 (ER 20)	70	35
302.02.16	SK 30	2 – 16 (ER 25)	70	42
302.02.20	SK 30	2 – 20 (ER 32)	70	50
302.02.26	SK 30	3 – 26 (ER 40)	70	63
302.02.10.1	SK 30	1 – 10 (ER 16)	100	32
302.02.13.1	SK 30	2 – 13 (ER 20)	100	35
302.02.16.1	SK 30	2 – 16 (ER 25)	100	42
302.02.20.1	SK 30	2 – 20 (ER 32)	100	50
402.02.10	SK 40	1 – 10 (ER 16)	63	32
402.02.13	SK 40	2 – 13 (ER 20)	70	35
402.02.16	SK 40	2 – 16 (ER 25)	60	42
402.02.20	SK 40	2 – 20 (ER 32)	70	50
402.02.26	SK 40	3 – 26 (ER 40)	80	63
402.02.10.1	SK 40	1 – 10 (ER 16)	100	32
402.02.13.1	SK 40	2 – 13 (ER 20)	100	35
402.02.16.1	SK 40	2 – 16 (ER 25)	100	42
402.02.20.1	SK 40	2 – 20 (ER 32)	100	50
402.02.26.1	SK 40	3 – 26 (ER 40)	100	63

Lieferumfang: Mit gewuchteter Spannmutter
Delivery: With balanced clamping nut
Livraison: Avec écrou de serrage équilibré





DIN 6499 (ISO 15488) System ER

Collet chucks for collets DIN 6499 (ISO 15488) ER-system
Mandrins à pinces pour pinces DIN 6499 (ISO 15488) système ER

1



Verwendung:
Zur Aufnahme von Werkzeugen mit Zylinderschaft in Spannzangen.

Application:
For mounting straight-shank tools in collets.

Application:
Pour le serrage d'outils avec queue cylindrique dans des pinces de serrage.

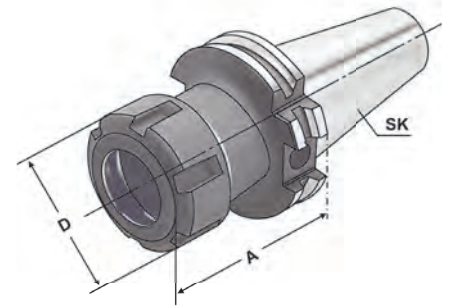

DIN 69871



AD/B

 $\nabla \leq 0,003$ G6.3
15.000 min⁻¹

14.04

Bestell-Nr. Order no. Référence	SK	Spannbereich Capacity Capacité	A	D
403.02.10	SK 40	1 – 10 (ER 16)	63	32
403.02.13	SK 40	2 – 13 (ER 20)	70	35
403.02.16	SK 40	2 – 16 (ER 25)	60	42
403.02.20	SK 40	2 – 20 (ER 32)	70	50
403.02.26	SK 40	3 – 26 (ER 40)	80	63
403.02.10.1	SK 40	1 – 10 (ER 16)	100	32
403.02.13.1	SK 40	2 – 13 (ER 20)	100	35
403.02.16.1	SK 40	2 – 16 (ER 25)	100	42
403.02.20.1	SK 40	2 – 20 (ER 32)	100	50
403.02.26.1	SK 40	3 – 26 (ER 40)	100	63
403.02.10.2	SK 40	1 – 10 (ER 16)	160	32
403.02.13.2	SK 40	2 – 13 (ER 20)	160	35
403.02.16.2	SK 40	2 – 16 (ER 25)	160	42
403.02.20.2	SK 40	2 – 20 (ER 32)	160	50
403.02.26.2	SK 40	3 – 26 (ER 40)	160	63
403.02.10.3	SK 40	1 – 10 (ER 16)	200	32
403.02.13.3	SK 40	2 – 13 (ER 20)	200	35
403.02.16.3	SK 40	2 – 16 (ER 25)	200	42
403.02.20.3	SK 40	2 – 20 (ER 32)	200	50
403.02.26.3	SK 40	3 – 26 (ER 40)	200	63

Lieferumfang: Mit gewichteter Spannmutter
Delivery: With balanced clamping nut
Livraison: Avec écrou de serrage équilibré



9.03



10.11



10.22

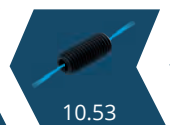

10.53



10.24

DIN 6499 (ISO 15488) System ER

Collet chucks for collets DIN 6499 (ISO 15488) ER-system
Mandrins à pinces pour pinces DIN 6499 (ISO 15488) système ER



Verwendung:
Zur Aufnahme von Werkzeugen mit Zylinderschaft in Spannzangen.

Application:
For mounting straight-shank tools in collets.

Application:
Pour le serrage d'outils avec queue cylindrique dans des pinces de serrage.

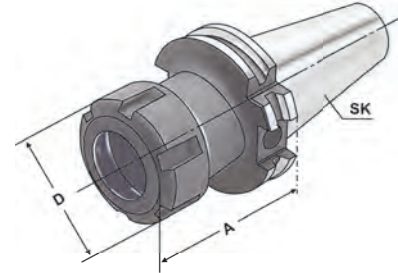

1

DIN 69871



AD/B

 $\nabla \leq 0,003$ G6.3
15.000 min⁻¹

Bestell-Nr. Order no. Référence	SK	Spannbereich Capacity Capacité	A	D
503.02.10	SK 50	1 – 10 (ER 16)	70	32
503.02.13	SK 50	2 – 13 (ER 20)	70	35
503.02.16	SK 50	2 – 16 (ER 25)	60	42
503.02.20	SK 50	2 – 20 (ER 32)	70	50
503.02.26	SK 50	3 – 26 (ER 40)	80	63
503.02.10.1	SK 50	1 – 10 (ER 16)	100	32
503.02.13.1	SK 50	2 – 13 (ER 20)	100	35
503.02.16.1	SK 50	2 – 16 (ER 25)	100	42
503.02.20.1	SK 50	2 – 20 (ER 32)	100	50
503.02.26.1	SK 50	3 – 26 (ER 40)	100	63
503.02.10.2	SK 50	1 – 10 (ER 16)	160	32
503.02.13.2	SK 50	2 – 13 (ER 20)	160	35
503.02.16.2	SK 50	2 – 16 (ER 25)	160	42
503.02.20.2	SK 50	2 – 20 (ER 32)	160	50
503.02.26.2	SK 50	3 – 26 (ER 40)	160	63
503.02.10.3	SK 50	1 – 10 (ER 16)	200	32
503.02.13.3	SK 50	2 – 13 (ER 20)	200	35
503.02.16.3	SK 50	2 – 16 (ER 25)	200	42
503.02.20.3	SK 50	2 – 20 (ER 32)	200	50
503.02.26.3	SK 50	3 – 26 (ER 40)	200	63

Lieferumfang: Mit gewichteter Spannmutter
Delivery: With balanced clamping nut
Livraison: Avec écrou de serrage équilibré





Collet chucks for collets KPS-system
Mandrins à pinces pour pinces système KPS



Verwendung:
Zur Aufnahme von Werkzeugen mit Zylinder-
schaft in Spannzangen.
Für Anwendungen im HSC-Bereich und für
hochpräzise Bearbeitungsergebnisse.

Application:
For mounting straight-shank tools in collets.
To use for high speed cutting and high precision
milling.

Application:
Pour le serrage d'outils avec queue cylindrique
dans des pinces de serrage.
Pour l'usage dans le coupage à grande vitesse
et dans l'usinage à grande précision.

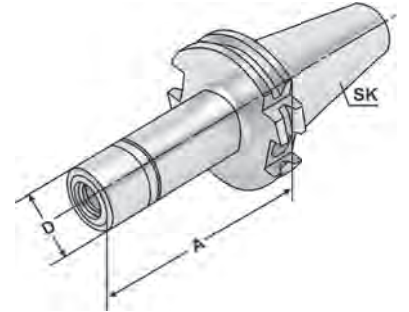

DIN 69871	AD	$\lambda \leq 0,003$	G2,5 30.000 min ⁻¹	14.04
-----------	----	----------------------	----------------------------------	-------

Bestell-Nr. Order no. Référence	SK	Spannbereich Capacity Capacité	A	D
302.03.10	SK 30	1 – 10 (KPS 10)	60	27,5
302.03.16	SK 30	4 – 16 (KPS 16)	60	40
302.03.10.1	SK 30	1 – 10 (KPS 10)	90	27,5
302.03.16.1	SK 30	4 – 16 (KPS 16)	90	40
402.03.10	SK 40	1 – 10 (KPS 10)	60	27,5
402.03.16	SK 40	4 – 16 (KPS 16)	60	40
402.03.10.1	SK 40	1 – 10 (KPS 10)	90	27,5
402.03.16.1	SK 40	4 – 16 (KPS 16)	90	40
402.03.10.2	SK 40	1 – 10 (KPS 10)	120	27,5
402.03.16.2	SK 40	4 – 16 (KPS 16)	120	40
402.03.10.3	SK 40	1 – 10 (KPS 10)	160	27,5
402.03.16.3	SK 40	4 – 16 (KPS 16)	160	40

Lieferumfang: Mit gewichteter Spannmutter
Delivery: With balanced clamping nut
Livraison: Avec écrou de serrage équilibré



Collet chucks for collets KPS-system

Mandrins à pinces pour pinces système KPS



Verwendung:
Zur Aufnahme von Werkzeugen mit Zylinderschaft in Spannzangen.
Für Anwendungen im HSC-Bereich und für hochpräzise Bearbeitungsergebnisse.

Application:
For mounting straight-shank tools in collets.
To use for high speed cutting and high precision milling.

Application:
Pour le serrage d'outils avec queue cylindrique dans des pinces de serrage.
Pour l'usage dans le coupage à grande vitesse et dans l'usinage à grande précision.

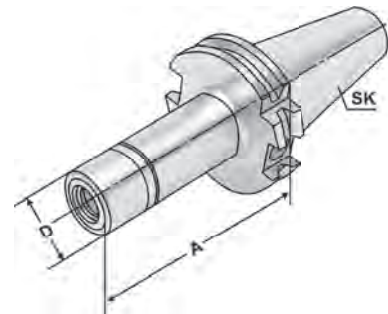

DIN 69871



AD

 $\nabla \leq 0,003$ G2.5
30.000 min⁻¹

14.04

Bestell-Nr. Order no. Référence	SK	Spannbereich Capacity Capacité	A	D
502.03.10	SK 50	1 – 10 (KPS 10)	105	27,5
502.03.16	SK 50	4 – 16 (KPS 16)	105	40
502.03.10.1	SK 50	1 – 10 (KPS 10)	135	27,5
502.03.16.1	SK 50	4 – 16 (KPS 16)	135	40
502.03.10.2	SK 50	1 – 10 (KPS 10)	165	27,5
502.03.16.2	SK 50	4 – 16 (KPS 16)	165	40

Lieferumfang: Mit gewuchteter Spannmutter
Delivery: With balanced clamping nut
Livraison: Avec écrou de serrage équilibré





DIN 6388 (ISO 10897) System OZ – ohne Mitnehmernuten

Collet chucks DIN 6391 for collets DIN 6388 (ISO 10897) OZ-system – without drive slots
Mandrins à pinces DIN 6391 pour pinces ISO 10897 système OZ – sans rainures d'entraînement



Verwendung:
Zur Aufnahme von Werkzeugen zur Holzbearbeitung mit Zylinderschaft in Spannzangen.

Application:
For mounting straight-shank tools for woodworking in collets.

Application:
Pour le serrage d'outils pour le travail du bois avec queue cylindrique dans des pinces de serrage.

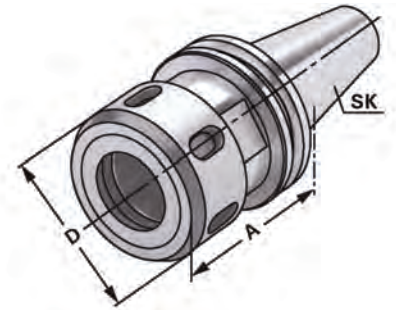

DIN 69871	AD	$\sqrt{\text{Ra}} \leq 0,003$	G6.3 20.000 min ⁻¹	14.04
-----------	----	-------------------------------	----------------------------------	-------

Bestell-Nr. Order no. Référence	SK	Spannbereich Capacity Capacité	A	D
302.61.25	SK 30	2 – 25 (OZ 25)	71	60
402.61.25	SK 40	2 – 25 (OZ 25)	63	60

Lieferumfang: Mit kugelgelagerter Spannmutter
Delivery: With ball bearing clamping nut
Livraison: Avec écrou de serrage à roulement à billes



DIN 6499 (ISO 15488) System ER – ohne MitnehmernutenCollet chucks for collets DIN 6499 (ISO 15488) ER-system – without drive slotsMandrins à pinces pour pinces DIN 6499 (ISO 15488) système ER – sans rainures d'entraînement

Verwendung:
Zur Aufnahme von Werkzeugen zur Holzbearbeitung mit Zylinderschaft in Spannzangen.

Application:
For mounting straight-shank tools for woodworking in collets.

Application:
Pour le serrage d'outils pour le travail du bois avec queue cylindrique dans des pinces de serrage.

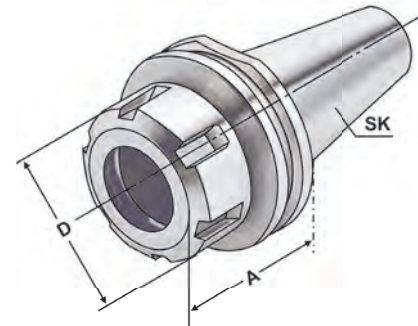

DIN 69871



AD

 $\nabla \leq 0,003$ G6,3
20.000 min⁻¹

14.04

Bestell-Nr. Order no. Référence	SK	Spannbereich Capacity Capacité	A	D
302.62.16	SK 30	2 – 16 (ER 25)	50	42
302.62.20	SK 30	2 – 20 (ER 32)	50	50
302.62.20.1	SK 30	2 – 20 (ER 32)	57	50
302.62.20.2	SK 30	2 – 20 (ER 32)	63	50
302.62.26	SK 30	3 – 26 (ER 40)	60	63
402.62.16	SK 40	2 – 16 (ER 25)	50	42
402.62.20	SK 40	2 – 20 (ER 32)	50	50
402.62.26	SK 40	3 – 26 (ER 40)	63	63

Lieferumfang: Mit gewichteter Spannmutter
Delivery: With balanced clamping nut
Livraison: Avec écrou de serrage équilibré



9.03



10.11



10.22



10.24



Collet chucks for collets DIN 6499 (ISO 15488) ER-system - Mini
Mandrins à pinces pour pinces DIN 6499 (ISO 15488) système ER - Mini

1



Verwendung:
Zur Aufnahme von Werkzeugen mit Zylinderschaft in Spannzangen.

Application:
For mounting straight-shank tools in collets.

Application:
Pour le serrage d'outils avec queue cylindrique dans des pinces de serrage.

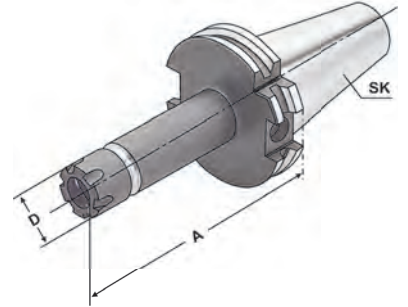

DIN 69871



AD/B

 $\nabla \leq 0,003$ G6.3
15.000 min⁻¹

14.04

Bestell-Nr. Order no. Référence	SK	Spannbereich Capacity Capacité	A	D
302.02.07*	SK 30	1 – 7 (ER 11)	70	16
302.02.07.1*	SK 30	1 – 7 (ER 11)	100	16
302.02.07.10*	SK 30	1 – 10 (ER 16)	70	22
302.02.07.10.1*	SK 30	1 – 10 (ER 16)	100	22
403.02.07	SK 40	1 – 7 (ER 11)	55	16
403.02.07.1	SK 40	1 – 7 (ER 11)	100	16
403.02.07.2	SK 40	1 – 7 (ER 11)	160	16
403.02.07.10	SK 40	1 – 10 (ER 16)	55	22
403.02.07.10.1	SK 40	1 – 10 (ER 16)	100	22
403.02.07.10.2	SK 40	1 – 10 (ER 16)	160	22
503.02.07.10.1	SK 50	1 – 10 (ER 16)	100	22
503.02.07.10.2	SK 50	1 – 10 (ER 16)	160	22

* DIN 69871 Form AD

* DIN 69871 form AD

* DIN 69871 forme AD

Lieferumfang: Mit gewuchteter Spannmutter
Delivery: With balanced clamping nut
Livraison: Avec écrou de serrage équilibré



9.03



10.10



10.23



10.24



High Performance Milling Chuck HKS-system
Mandrin de serrage à haute performance système HKS



Verwendung:
Zur Aufnahme von Werkzeugen mit Zylinderschaft nach DIN 1835 Form A+B+E und DIN 6535 Form HB+HE

Application:
For mounting straight-shank tools acc. DIN 1835 form A+B+E and DIN 6535 form HB+HE

Application:
Pour le serrage d'outils avec queue cylindrique suivant DIN 1835 forme A+B+E et DIN 6535 forme HB+HE

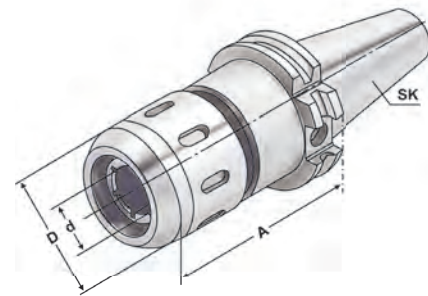

DIN 69871 AD/B $\sqrt{\text{Ra}} \leq 0,003$ $G6,3$ 15.000 min^{-1} 14.04

Bestell-Nr. Order no. Référence	SK	Spannbereich Capacity Capacité	A	D	d
403.64.20	SK 40	20 (HKS 20)	90	53	20
403.64.25	SK 40	25 (HKS 25)	105	63	25
403.64.32	SK 40	32 (HKS 32)	105	68	32
503.64.20	SK 50	20 (HKS 20)	90	53	20
503.64.25	SK 50	25 (HKS 25)	90	63	25
503.64.32	SK 50	32 (HKS 32)	90	68	32

Gewuchtete Ausführung

Balanced type
Type équilibré



Bestell-Nr. Order no. Référence	Abmessung Size Dimension
---------------------------------------	--------------------------------

Wuchten auf G 2,5 von vorgewuchteten Kemmler-Werkzeugen
Balancing at G 2.5 of pre-balanced Kemmler-tools
Équilibrage sur G 2,5 d'outils Kemmler pré-équilibrés

- W25 **Ohne Wuchtprotokoll**
Without balancing report
Sans protocole d'équilibrage
- W25.2 **Mit Wuchtprotokoll**
With balancing report
Avec protocole d'équilibrage

Wuchten von nicht vorgewuchteten Werkzeugen
Balancing of unbalanced tools
Équilibrage d'outils non-équilibrés

- W25.1 **Ohne Wuchtprotokoll**
Without balancing report
Sans protocole d'équilibrage



End mill holders DIN 6359 for end mills DIN 1835-B
 Porte-fraises DIN 6359 pour queues cylindriques DIN 1835-B

1



Verwendung:
 Zum Spannen von zylindrischen Werkzeugschäften mit seitlicher Spannfläche nach DIN 1835 Form B (Weldon).

Application:
 For mounting straight-shank tools with lateral flat according to DIN 1835 form B (Weldon).

Application:
 Pour le serrage d'outils avec queue cylindrique et avec méplat suivant DIN 1835 forme B (Weldon).

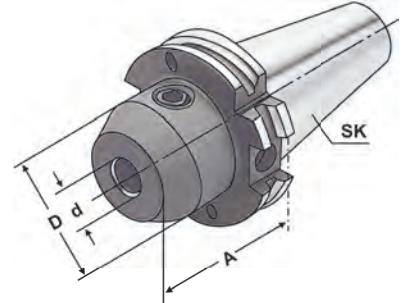

DIN 69871
 AD
 $\sqrt{\text{Ra}} \leq 0,003$
 G6.3 15.000 min⁻¹
 14.04

Bestell-Nr. Order no. Référence	SK	d ^{H4}	A	D
302.04.06	SK 30	6	50	25
302.04.08	SK 30	8	50	28
302.04.10	SK 30	10	50	35
302.04.12	SK 30	12	50	42
302.04.14	SK 30	14	63	44
302.04.16	SK 30	16	63	48
302.04.18	SK 30	18	63	50
302.04.20	SK 30	20	70	52
402.04.06	SK 40	6	50	25
402.04.08	SK 40	8	50	28
402.04.10	SK 40	10	50	35
402.04.12	SK 40	12	50	42
402.04.14	SK 40	14	50	44
402.04.16	SK 40	16	63	48
402.04.18	SK 40	18	63	50
402.04.20	SK 40	20	63	52
402.04.25	SK 40	25	100	65
402.04.32	SK 40	32	100	72
402.04.06.1	SK 40	6	100	25
402.04.08.1	SK 40	8	100	28
402.04.10.1	SK 40	10	100	35
402.04.12.1	SK 40	12	100	42
402.04.14.1	SK 40	14	100	44
402.04.16.1	SK 40	16	100	48
402.04.18.1	SK 40	18	100	50
402.04.20.1	SK 40	20	100	52

Hinweis: Ab d = 25 mit zwei Spannschrauben
Note: From d = 25 on two clamping screws
Observation: A partir de d = 25 avec deux vis de serrage

Lieferumfang: Mit Spannschraube
Delivery: With clamping screw
Livraison: Avec vis de serrage



End mill holders DIN 6359 for end mills DIN 1835-B
Porte-fraises DIN 6359 pour queues cylindriques DIN 1835-B



Verwendung:
Zum Spannen von zylindrischen Werkzeugschäften mit seitlicher Spannfläche nach DIN 1835 Form B (Weldon).

Application:
For mounting straight-shank tools with lateral flat according to DIN 1835 form B (Weldon).

Application:
Pour le serrage d'outils avec queue cylindrique et avec méplat suivant DIN 1835 forme B (Weldon).

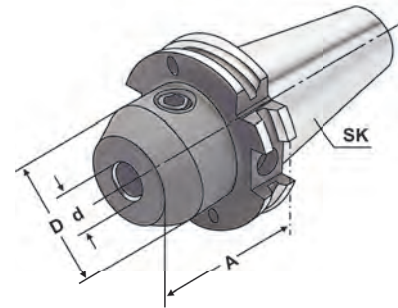

DIN 69871

 $\nabla \leq 0,003$ G6,3
15.000 min⁻¹

Bestell-Nr. Order no. Référence	SK	d ^{H4}	A	D
403.04.16.0	SK 40	16	35	45
403.04.20.0	SK 40	20	35	45
403.04.25.0	SK 40	25	35	50
403.04.32.0	SK 40	32	65	50
403.04.06	SK 40	6	50	25
403.04.08	SK 40	8	50	28
403.04.10	SK 40	10	50	35
403.04.12	SK 40	12	50	42
403.04.14	SK 40	14	50	44
403.04.16	SK 40	16	63	48
403.04.18	SK 40	18	63	50
403.04.20	SK 40	20	63	52
403.04.25	SK 40	25	100	65
403.04.32	SK 40	32	100	72
403.04.40	SK 40	40	120	80
403.04.06.1	SK 40	6	100	25
403.04.08.1	SK 40	8	100	28
403.04.10.1	SK 40	10	100	35
403.04.12.1	SK 40	12	100	42
403.04.14.1	SK 40	14	100	44
403.04.16.1	SK 40	16	100	48
403.04.18.1	SK 40	18	100	50
403.04.20.1	SK 40	20	100	52
403.04.06.2	SK 40	6	160	25
403.04.08.2	SK 40	8	160	28
403.04.10.2	SK 40	10	160	35
403.04.12.2	SK 40	12	160	42
403.04.14.2	SK 40	14	160	44
403.04.16.2	SK 40	16	160	48
403.04.18.2	SK 40	18	160	50
403.04.20.2	SK 40	20	160	52
403.04.25.2	SK 40	25	160	65
403.04.32.2	SK 40	32	160	72
403.04.40.2	SK 40	40	160	80

Hinweis: Ab d = 25 mit zwei Spannschrauben
Note: From d = 25 on two clamping screws
Observation: A partir de d = 25 avec deux vis de serrage

Lieferumfang: Mit Spannschraube
Delivery: With clamping screw
Livraison: Avec vis de serrage

End mill holders DIN 6359 for end mills DIN 1835-B
 Porte-fraises DIN 6359 pour queues cylindriques DIN 1835-B

1



Verwendung:
 Zum Spannen von zylindrischen Werkzeugschäften mit seitlicher Spannfläche nach DIN 1835 Form B (Weldon).

Application:
 For mounting straight-shank tools with lateral flat according to DIN 1835 form B (Weldon).

Application:
 Pour le serrage d'outils avec queue cylindrique et avec méplat suivant DIN 1835 forme B (Weldon).

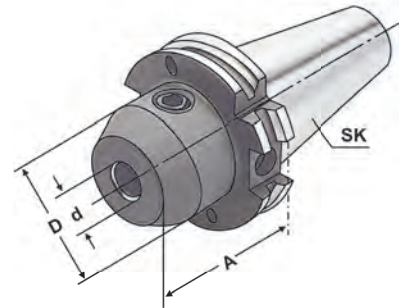

DIN 69871
 AD/B
 $\sqrt{\text{Ra}} \leq 0,003$
 G6.3 15.000 min⁻¹
 14.04

Bestell-Nr. Order no. Référence	SK	d ^{H4}	A	D
503.04.06	SK 50	6	63	25
503.04.08	SK 50	8	63	28
503.04.10	SK 50	10	63	35
503.04.12	SK 50	12	63	42
503.04.14	SK 50	14	63	44
503.04.16	SK 50	16	63	48
503.04.18	SK 50	18	63	50
503.04.20	SK 50	20	63	52
503.04.25	SK 50	25	80	65
503.04.32	SK 50	32	100	72
503.04.40	SK 50	40	100	80
503.04.06.1	SK 50	6	100	25
503.04.08.1	SK 50	8	100	28
503.04.10.1	SK 50	10	100	35
503.04.12.1	SK 50	12	100	42
503.04.14.1	SK 50	14	100	44
503.04.16.1	SK 50	16	100	48
503.04.18.1	SK 50	18	100	50
503.04.20.1	SK 50	20	100	52
503.04.25.1	SK 50	25	120	65

Hinweis: Ab d = 25 mit zwei Spanschrauben
Note: From d = 25 on two clamping screws
Observation: A partir de d = 25 avec deux vis de serrage

Lieferumfang: Mit Spanschraube
Delivery: With clamping screw
Livraison: Avec vis de serrage



End mill holders DIN 6359 for end mills DIN 1835-B
 Porte-fraises DIN 6359 pour queues cylindriques DIN 1835-B



Verwendung:
 Zum Spannen von zylindrischen Werkzeugschäften mit seitlicher Spannfläche nach DIN 1835 Form B (Weldon).

Application:
 For mounting straight-shank tools with lateral flat according to DIN 1835 form B (Weldon).

Application:
 Pour le serrage d'outils avec queue cylindrique et avec méplat suivant DIN 1835 forme B (Weldon).

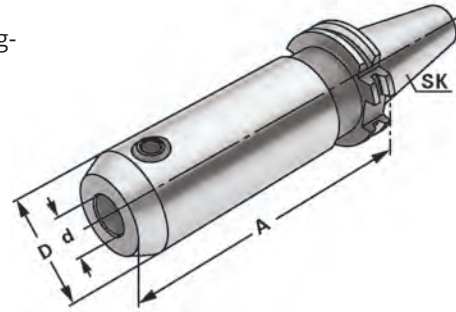

DIN 69871

 $\nabla \leq 0,003$ G6,3
15.000 min⁻¹

Bestell-Nr. Order no. Référence	SK	d ^{H4}	A	D
503.04.06.2	SK 50	6	160	25
503.04.08.2	SK 50	8	160	28
503.04.10.2	SK 50	10	160	35
503.04.12.2	SK 50	12	160	42
503.04.14.2	SK 50	14	160	44
503.04.16.2	SK 50	16	160	48
503.04.18.2	SK 50	18	160	50
503.04.20.2	SK 50	20	160	52
503.04.25.2	SK 50	25	160	65
503.04.32.2	SK 50	32	160	72
503.04.40.2	SK 50	40	160	80
503.04.06.3	SK 50	6	200	25
503.04.08.3	SK 50	8	200	28
503.04.10.3	SK 50	10	200	35
503.04.12.3	SK 50	12	200	42
503.04.14.3	SK 50	14	200	44
503.04.16.3	SK 50	16	200	48
503.04.18.3	SK 50	18	200	50
503.04.20.3	SK 50	20	200	52
503.04.25.3	SK 50	25	200	65
503.04.32.3	SK 50	32	200	72
503.04.40.3	SK 50	40	200	80

Hinweis: Ab d = 25 mit zwei Spansschrauben
Note: From d = 25 on two clamping screws
Observation: A partir de d = 25 avec deux vis de serrage

Lieferumfang: Mit Spansschraube
Delivery: With clamping screw
Livraison: Avec vis de serrage





für Zylinderschäfte DIN 1835-B

End mill holders DIN 6359 with coolant channels for end mills DIN 1835-B

Porte-fraises DIN 6359 avec canaux d'arrosage pour queues cylindriques DIN 1835-B

1

**Verwendung:**

Zum Spannen von zylindrischen Werkzeugschäften mit seitlicher Spannfläche nach DIN 1835 Form B (Weldon). Mit Kühlkanälen für optimale Kühlung der Werkzeugschneide.

Application:

For mounting straight-shank tools with lateral flat according to DIN 1835 form B (Weldon). With coolant channels for optimal coolant at the cutting edge.

Application:

Pour le serrage d'outils avec queue cylindrique et avec méplat suivant DIN 1835 forme B (Weldon). Avec canaux d'arrosage pour un refroidissement optimal aux lames.

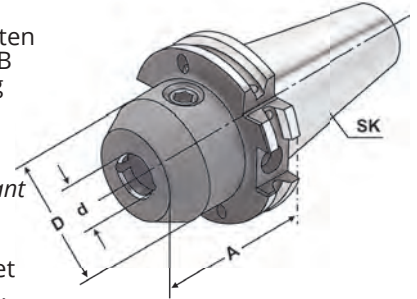

DIN 69871



AD/B

 $\nabla \leq 0,003$ G6.3
15.000 min⁻¹

14.04

Bestell-Nr. Order no. Référence	SK	d ^{H4}	A	D
403.04.06.K	SK 40	6	50	25
403.04.08.K	SK 40	8	50	28
403.04.10.K	SK 40	10	50	35
403.04.12.K	SK 40	12	50	42
403.04.14.K	SK 40	14	50	44
403.04.16.K	SK 40	16	63	48
403.04.18.K	SK 40	18	63	50
403.04.20.K	SK 40	20	63	52
403.04.25.K	SK 40	25	100	65
403.04.32.K	SK 40	32	100	72
403.04.40.K	SK 40	40	120	80
403.04.06.1.K	SK 40	6	100	25
403.04.08.1.K	SK 40	8	100	28
403.04.10.1.K	SK 40	10	100	35
403.04.12.1.K	SK 40	12	100	42
403.04.14.1.K	SK 40	14	100	44
403.04.16.1.K	SK 40	16	100	48
403.04.18.1.K	SK 40	18	100	50
403.04.20.1.K	SK 40	20	100	52

Hinweis:

Ab d = 25 mit zwei Spannschrauben
d = 6 bis 18 mit zwei Kühlkanälen
d = 20 bis 40 mit vier Kühlkanälen

Für Werkzeuge mit innerer Kühlmittelzufuhr muss ein O-Ring eingesetzt werden.

Note:

From d = 25 on two clamping screws
d = 6 to 18 with two coolant channels
d = 20 to 40 with four coolant channels

For tools with through coolant an O-ring must be used.

Observation:

A partir de d = 25 avec deux vis de serrage
d = 6 bis 18 avec deux canaux d'arrosage
d = 20 bis 40 avec quatre canaux d'arrosage

Pour outils avec arrosage interne il faut utiliser un joint torique.

Lieferumfang:

Mit Spannschraube und O-Ring

Delivery:

With clamping screw and O-ring

Livraison:

Avec vis de serrage et joint torique



10.52



10.24

für Zylinderschäfte DIN 1835-B

End mill holders DIN 6359 with coolant channels for end mills DIN 1835-B

Porte-fraises DIN 6359 avec canaux d'arrosage pour queues cylindriques DIN 1835-B

**Verwendung:**

Zum Spannen von zylindrischen Werkzeugschäften mit seitlicher Spannfläche nach DIN 1835 Form B (Weldon). Mit Kühlkanälen für optimale Kühlung der Werkzeugschneide.

Application:

For mounting straight-shank tools with lateral flat according to DIN 1835 form B (Weldon). With coolant channels for optimal coolant at the cutting edge.

Application:

Pour le serrage d'outils avec queue cylindrique et avec méplat suivant DIN 1835 forme B (Weldon). Avec canaux d'arrosage pour un refroidissement optimal aux lames.

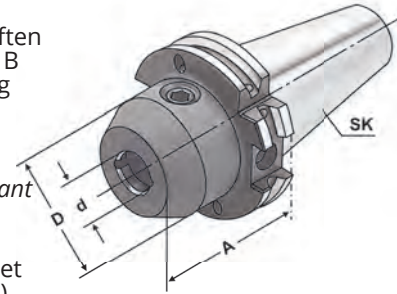

DIN 69871



AD/B

 $\nabla \leq 0,003$
 $G6,3$
 15.000 min^{-1}
Bestell-Nr.
Order no.
Référence

SK

d^{H4}

A

D

503.04.06.K

SK 50

6

63

25

503.04.08.K

SK 50

8

63

28

503.04.10.K

SK 50

10

63

35

503.04.12.K

SK 50

12

63

42

503.04.14.K

SK 50

14

63

44

503.04.16.K

SK 50

16

63

48

503.04.18.K

SK 50

18

63

50

503.04.20.K

SK 50

20

63

52

503.04.25.K

SK 50

25

80

65

503.04.32.K

SK 50

32

100

72

503.04.40.K

SK 50

40

100

80

503.04.06.1.K

SK 50

6

100

25

503.04.08.1.K

SK 50

8

100

28

503.04.10.1.K

SK 50

10

100

35

503.04.12.1.K

SK 50

12

100

42

503.04.14.1.K

SK 50

14

100

44

503.04.16.1.K

SK 50

16

100

48

503.04.18.1.K

SK 50

18

100

50

503.04.20.1.K

SK 50

20

100

52

Hinweis:

Ab d = 25 mit zwei Spanschrauben
 d = 6 bis 18 mit zwei Kühlkanälen
 d = 20 bis 40 mit vier Kühlkanälen

Für Werkzeuge mit innerer Kühlmittelzufuhr muss ein O-Ring eingesetzt werden.

Note:

From d = 25 on two clamping screws
 d = 6 to 18 with two coolant channels
 d = 20 to 40 with four coolant channels

For tools with through coolant an O-ring must be used.

Observation:

A partir de d = 25 avec deux vis de serrage
 d = 6 bis 18 avec deux canaux d'arrosage
 d = 20 bis 40 avec quatre canaux d'arrosage

Pour outils avec arrosage interne il faut utiliser un joint torique.

Lieferumfang:

Mit Spanschraube und O-Ring

Delivery:

With clamping screw and O-ring

Livraison:

Avec vis de serrage et joint torique



10.52



10.24

End mill holders DIN 6359 for end mills DIN 1835-E
 Porte-fraises DIN 6359 pour queues cylindriques DIN 1835-E

1



Verwendung:
 Zum Spannen von zylindrischen Werkzeugschäften mit geneigter Spannfläche nach DIN 1835 Form E (Whistle Notch).

Application:
 For mounting straight-shank tools and inclined flat according to DIN 1835 form E (Whistle Notch).

Application:
 Pour le serrage d'outils avec queue cylindrique et avec méplat incliné suivant DIN 1835 forme E (Whistle Notch).

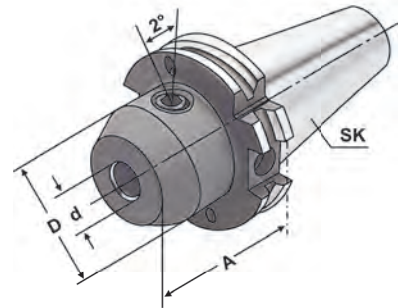

DIN 69871
 AD/B
 $\sqrt{\text{Ra}} \leq 0,003$
 G6.3 15.000 min⁻¹
 14.04

Bestell-Nr. Order no. Référence	SK	d ^{H4}	A	D
403.05.06	SK 40	6	50	25
403.05.08	SK 40	8	50	28
403.05.10	SK 40	10	50	35
403.05.12	SK 40	12	50	42
403.05.14	SK 40	14	50	44
403.05.16	SK 40	16	63	48
403.05.18	SK 40	18	63	50
403.05.20	SK 40	20	63	52
403.05.25	SK 40	25	100	65
403.05.32	SK 40	32	100	72
403.05.40	SK 40	40	120	80
503.05.06	SK 50	6	63	25
503.05.08	SK 50	8	63	28
503.05.10	SK 50	10	63	35
503.05.12	SK 50	12	63	42
503.05.14	SK 50	14	63	44
503.05.16	SK 50	16	63	48
503.05.18	SK 50	18	63	50
503.05.20	SK 50	20	63	52
503.05.25	SK 50	25	80	65
503.05.32	SK 50	32	100	72
503.05.40	SK 50	40	100	80

Hinweis: Ab d = 25 mit zwei Spannschrauben
Note: From d = 25 on two clamping screws
Observation: A partir de d = 25 avec deux vis de serrage

Lieferumfang: Mit Spannschraube und axialer Verstellechraube
Delivery: With clamping screw and axial adjustment bolt
Livraison: Avec vis de serrage et vis de butée axiale



Adaptor sleeves for MT with tang DIN 6383
 Douilles de réduction pour CM à tenon DIN 6383



Verwendung:
 Zur Aufnahme von Werkzeugen mit Morsekegelschaft und Austreibblappen nach DIN 228-1 Form B.

Application:
 For mounting tools with Morse taper shank and tang according to DIN 228-1 form B.

Application:
 Pour le serrage d'outils avec queue cône Morse et tenon suivant DIN 228-1 forme B.

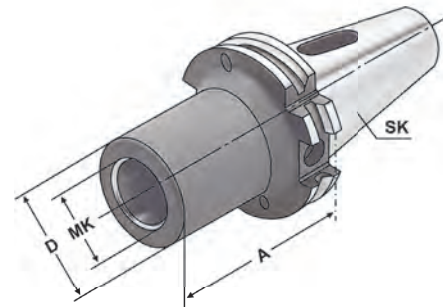

1

DIN 69871

AD/B

 $\nabla \leq 0,005$ G6,3
15.000 min⁻¹

Bestell-Nr. Order no. Référence	SK	MK MT CM	A	D
302.07.01 *	SK 30	1	50	25
302.07.02 *	SK 30	2	60	32
302.07.03 *	SK 30	3	80	40
402.07.01 *	SK 40	1	50	25
402.07.02 *	SK 40	2	50	32
402.07.03 *	SK 40	3	70	40
402.07.04 *	SK 40	4	95	48
403.07.01	SK 40	1	50	25
403.07.02	SK 40	2	50	32
403.07.03	SK 40	3	70	40
403.07.04	SK 40	4	95	48
402.07.02.1 *	SK 40	2	117	32
402.07.03.1 *	SK 40	3	133	40
402.07.04.1 *	SK 40	4	156	48
503.07.01	SK 50	1	45	25
503.07.02	SK 50	2	60	32
503.07.03	SK 50	3	65	40
503.07.04	SK 50	4	95	48
503.07.05	SK 50	5	105	63
502.07.02.1 *	SK 50	2	117	32
502.07.03.1 *	SK 50	3	137	40
502.07.04.1 *	SK 50	4	167	48
502.07.05.1 *	SK 50	5	197	63

* DIN 69871 Form AD

* DIN 69871 form AD

* DIN 69871 forme AD



8.12

10.24



Adaptor sleeves for MT with drawbar thread DIN 6364
 Douilles de réduction pour CM avec filetage DIN 6364



Verwendung:
 Zum Spannen von Werkzeugen mit Morsekegelschaft und Anzugsgewinde nach DIN 228-1 Form A.

Application:
 For clamping tools with Morse taper shank and thread according to DIN 228-1 form A.

Application:
 Pour le serrage d'outils avec queue cône Morse et filetage suivant DIN 228-1 forme A.

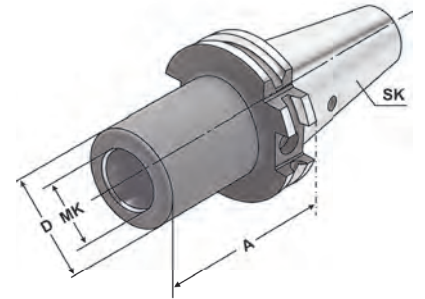

DIN 69871 Form A $\nabla \leq 0,005$ G6,3 15.000 min⁻¹

Bestell-Nr. Order no. Référence	SK	MK MT CM	M	A	D
402.08.01	SK 40	1	M6	50	25
402.08.02	SK 40	2	M10	50	32
402.08.03	SK 40	3	M12	70	40
402.08.04	SK 40	4	M16	95	48
402.08.04A*	SK 40	4	M16	110	63
502.08.01	SK 50	1	M6	45	25
502.08.02	SK 50	2	M10	60	32
502.08.03	SK 50	3	M12	65	40
502.08.04	SK 50	4	M16	70	48
502.08.04A*	SK 50	4	M16	85	63
502.08.05	SK 50	5	M20	100	63
502.08.05A*	SK 50	5	M20	118	78

- * Mit Mitnahmeausfräsung nach DIN 2201
- * With drive flats according to DIN 2201
- * Avec des fraises d'entraînement suivant DIN 2201

Lieferumfang: Mit eingebauter Fräseranzugsschraube
Delivery: With built-in tightening bolt
Livraison: Avec vis de serrage montée



Adaptor sleeves for ISO-toolholders
 Douilles de réduction pour porte-outils ISO/SA



Verwendung:
 Zur Aufnahme von Steilkegeln nach DIN 69871, JIS B 6339 und DIN 2080.

Application:
 For holding tapers according to DIN 69871, JIS B 6339 and DIN 2080.

Application:
 Pour le serrage de porte-outils suivant DIN 69871, JIS B 6339 et DIN 2080.

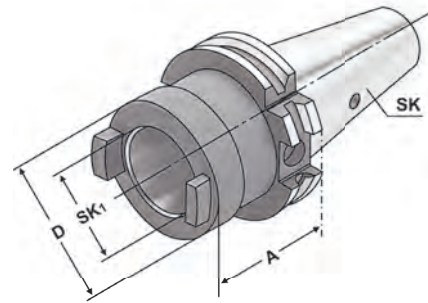

DIN 69871 Form A $\nabla \leq 0,005$ G6,3 15.000 min⁻¹

Bestell-Nr. Order no. Référence	SK	SK ₁	A	D
402.09.30	SK 40	SK 30	50	50
402.09.40	SK 40	SK 40	100	63
502.09.40	SK 50	SK 40	70	70
502.09.50	SK 50	SK 50	120	97

- Hinweis:** Lieferung erfolgt mit eingebauter Schraube für Werkzeuge mit gekürztem Steilkegel. Schraube für DIN 2080 Werkzeuge beiliegend.
- Note:** Delivered with a built-in screw for shortened taper tools. Additional screw for DIN 2080 tools included.
- Observation:** Livraison avec un vis incorporée pour outils à cône court. Vis pour cônes DIN 2080 incluse.



Combi shell mill holders DIN 6358 Porte-fraises à double usage DIN 6358

1



Verwendung:
Zur Aufnahme von Walzen-, Walzenstirnfräsern oder Messerköpfen mit Längs- oder Quernut.

Application:
For mounting milling cutters with transverse or longitudinal groove.

Application:
Pour le serrage de fraises à rainure transversale ou à rainure longitudinale.

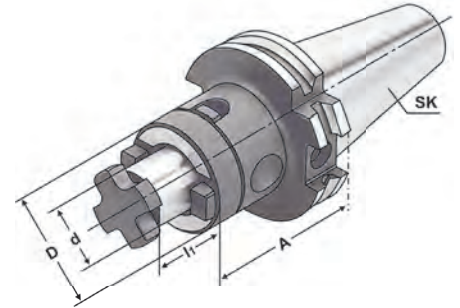

DIN 69871



AD/B

$\nabla \leq 0,005$

G6,3
15.000 min⁻¹

Bestell-Nr. Order no. Référence	SK	d _{h6}	A	l ₁	D
302.10.16 *	SK 30	16	50	17	32
302.10.22 *	SK 30	22	50	19	40
302.10.27 *	SK 30	27	55	21	48
302.10.32 *	SK 30	32	60	24	58
403.10.16	SK 40	16	55	17	32
403.10.22	SK 40	22	55	19	40
403.10.27	SK 40	27	55	21	48
403.10.32	SK 40	32	60	24	58
403.10.40	SK 40	40	60	27	70
403.10.16.1	SK 40	16	100	17	32
403.10.22.1	SK 40	22	100	19	40
403.10.27.1	SK 40	27	100	21	48
403.10.32.1	SK 40	32	100	24	58
403.10.40.1	SK 40	40	100	27	70
403.10.16.2	SK 40	16	160	17	32
403.10.22.2	SK 40	22	160	19	40
403.10.27.2	SK 40	27	160	21	48
403.10.32.2	SK 40	32	160	24	58
403.10.40.2	SK 40	40	160	27	70

* DIN 69871 Form AD
* DIN 69871 form AD
* DIN 69871 forme AD

Lieferumfang: Mit Fräseranzugsschraube, Mitnehmerring und Passfeder
Delivery: With retaining screw, driving ring and feather key
Livraison: Avec vis de serrage, bague d'entraînement et clavette

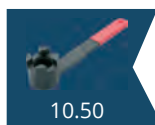

Combi shell mill holders DIN 6358
Porte-fraises à double usage DIN 6358



Verwendung:
Zur Aufnahme von Walzen-, Walzenstirnfräsern oder Messerköpfen mit Längs- oder Quernut.

Application:
For mounting milling cutters with transverse or longitudinal groove.

Application:
Pour le serrage de fraises à rainure transversale ou à rainure longitudinale.

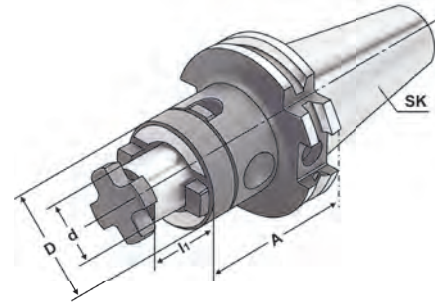

DIN 69871 AD/B $\sqrt{\leq 0,005}$ $\overset{G6.3}{15.000 \text{ min}^{-1}}$

Bestell-Nr. Order no. Référence	SK	d_{h6}	A	l_1	D
503.10.16	SK 50	16	55	17	32
503.10.22	SK 50	22	55	19	40
503.10.27	SK 50	27	55	21	48
503.10.32	SK 50	32	55	24	58
503.10.40	SK 50	40	55	27	70
503.10.16.1	SK 50	16	100	17	32
503.10.22.1	SK 50	22	100	19	40
503.10.27.1	SK 50	27	100	21	48
503.10.32.1	SK 50	32	100	24	58
503.10.40.1	SK 50	40	100	27	70
503.10.16.2	SK 50	16	160	17	32
503.10.22.2	SK 50	22	160	19	40
503.10.27.2	SK 50	27	160	21	48
503.10.32.2	SK 50	32	160	24	58
503.10.40.2	SK 50	40	160	27	70

Lieferumfang: Mit Fräseranzugsschraube, Mitnehmerring und Passfeder
Delivery: With retaining screw, driving ring and feather key
Livraison: Avec vis de serrage, bague d'entraînement et clavette





Anlagefläche und Kühlkanalbohrungen an der Stirnseite

Shell mill holders DIN 6357 with enlarged contact face and coolant exit bores on the end face

Porte-fraises à trou lisse DIN 6357 avec face de contact élargie et conduits pour l'arrosage frontal

1



Verwendung:

Zur Aufnahme von Messerköpfen und Fräsern mit Quernut.

Application:

For mounting milling cutters with transversal groove.

Application:

Pour le serrage de fraises à rainure transversale.

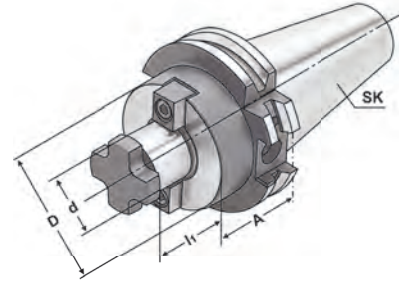

DIN 69871



AD/B

$\nabla \leq 0,005$

G6.3
15.000 min⁻¹

Bestell-Nr. Order no. Référence	SK	d _{h6}	A	l ₁	D
302.11.16 *	SK 30	16	40	17	38
302.11.22 *	SK 30	22	40	19	48
302.11.27 *	SK 30	27	50	21	58
302.11.32 *	SK 30	32	50	24	78
402.11.16 *	SK 40	16	35	17	38
402.11.22 *	SK 40	22	35	19	48
402.11.27 *	SK 40	27	40	21	58
402.11.32 *	SK 40	32	50	24	78
402.11.40 *	SK 40	40	50	27	88
403.11.16	SK 40	16	35	17	38
403.11.22	SK 40	22	35	19	48
403.11.27	SK 40	27	40	21	58
403.11.32	SK 40	32	50	24	78
403.11.40	SK 40	40	50	27	88
403.11.16.1	SK 40	16	100	17	38
403.11.22.1	SK 40	22	100	19	48
403.11.27.1	SK 40	27	100	21	58
403.11.32.1	SK 40	32	100	24	78
403.11.40.1	SK 40	40	100	27	88
403.11.16.2	SK 40	16	160	17	38
403.11.22.2	SK 40	22	160	19	48
403.11.27.2	SK 40	27	160	21	58
403.11.32.2	SK 40	32	160	24	78
403.11.40.2	SK 40	40	160	27	88

*** DIN 69871 Form AD**

* DIN 69871 form AD

* DIN 69871 forme AD

SK 30 ohne Kühlkanalbohrungen an der Stirnseite

SK 30 without coolant exit bores on the end face

SK 30 sans alésages pour l'arrosage frontal

d = 40/d = 60:

Für große Planfräser mit vier zusätzlichen Gewindebohrungen nach DIN 2079.

For large diameter face mill cutters with four additional threaded holes according to DIN 2079.

Pour fraises à surfacer à grands diamètres avec quatre trous taraudés additionnels suivant DIN 2079.

Lieferumfang:

Mit Mitnehmersteinen, Kreuzschraube und Zylinderkopfschraube nach DIN 912

für Fräser mit innerer Kühlmittelzufuhr. Bei d = 60 nur mit vier Befestigungsschrauben nach DIN 912.

Delivery:

With drivers, cross head retaining screw and cylinder head retaining screw for cutters with central coolant.

For d = 60 only with four fixation screws according to DIN 912.

Livraison:

Avec tenons, une vis cruciforme et une vis à tête cylindrique suivant DIN 912 pour fraises avec arrosage central. Pour d = 60 seulement avec quatre vis de fixation suivant DIN 912.

Anlagefläche und Kühlkanalbohrungen an der Stirnseite

Shell mill holders DIN 6357 with enlarged contact face and coolant exit bores on the end face
 Porte-fraises à trou lisse DIN 6357 avec face de contact élargie et conduits pour l'arrosage frontal



Verwendung:
 Zur Aufnahme von Messerköpfen und Fräsern mit Quernut.

Application:
 For mounting milling cutters with transversal groove.

Application:
 Pour le serrage de fraises à rainure transversale.

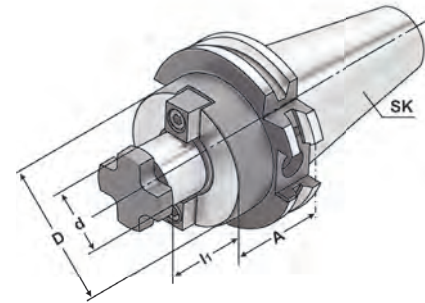

DIN 69871 AD/B $\sqrt{\leq 0,005}$ $G6,3$ 15.000 min^{-1}

Bestell-Nr. Order no. Référence	SK	d _{h6}	A	l ₁	D
503.11.16	SK 50	16	45	17	38
503.11.22	SK 50	22	35	19	48
503.11.27	SK 50	27	40	21	58
503.11.32	SK 50	32	50	24	78
503.11.40	SK 50	40	50	27	88
503.11.60	SK 50	60	70	40	129
503.11.16.1	SK 50	16	100	17	38
503.11.22.1	SK 50	22	100	19	48
503.11.27.1	SK 50	27	100	21	58
503.11.32.1	SK 50	32	100	24	78
503.11.40.1	SK 50	40	100	27	88
503.11.16.2	SK 50	16	160	17	38
503.11.22.2	SK 50	22	160	19	48
503.11.27.2	SK 50	27	160	21	58
503.11.32.2	SK 50	32	160	24	78
503.11.40.2	SK 50	40	160	27	88
503.11.16.3	SK 50	16	200	17	38
503.11.22.3	SK 50	22	200	19	48
503.11.27.3	SK 50	27	200	21	58
503.11.32.3	SK 50	32	200	24	78
503.11.40.3	SK 50	40	200	27	88

d = 40/d = 60: Für große Planfräser mit vier zusätzlichen Gewindebohrungen nach DIN 2079.
 For large diameter face mill cutters with four additional threaded holes according to DIN 2079.
 Pour fraises à surfacer à grands diamètres avec quatre trous taraudés additionnels suivant DIN 2079.

Lieferumfang: Mit Mitnehmersteinen, Kreuzschraube und Zylinderkopfschraube nach DIN 912 für Fräser mit innerer Kühlmittelzufuhr.
 Bei d = 60 nur mit vier Befestigungsschrauben nach DIN 912.

Delivery: With drivers, cross head retaining screw and cylinder head retaining screw for cutters with central coolant.
 For d = 60 only with four fixation screws according to DIN 912.

Livraison: Avec tenons, une vis cruciforme et une vis à tête cylindrique suivant DIN 912 pour fraises avec arrosage central.
 Pour d = 60 seulement avec quatre vis de fixation suivant DIN 912.





Boring holders for drills with indexable inserts form E1
Portes forets pour forets à plaquettes réversibles forme E1



Verwendung:
Zur Aufnahme von allen nach DIN 6595 genormten Vollbohrern mit Zylinderschaft.

Application:
For mounting solid drills with cylindrical shank according to DIN 6595.

Application:
Pour le serrage de forets à queue cylindrique suivant DIN 6595.

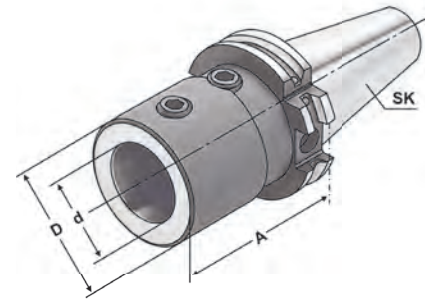

DIN 69871	AD/B	$\nabla \leq 0,004$	G6,3 15.000 min ⁻¹
-----------	------	---------------------	----------------------------------

Bestell-Nr. Order no. Référence	SK	d ^{H5}	A	D
403.51.20	SK 40	20	65	40
403.51.25	SK 40	25	70	45
403.51.32	SK 40	32	75	52
503.51.20	SK 50	20	70	40
503.51.25	SK 50	25	70	45
503.51.32	SK 50	32	70	52
503.51.40	SK 50	40	80	60

Hinweis: Plangeschliffene Anlagefläche
Note: Contact surface precision grinded
Observation: Surface de montage rectifié précisément

Lieferumfang: Mit Spannschrauben
Delivery: With clamping screws
Livraison: Avec vis de serrage



Drill chuck adaptors DIN 238
Arbres pour mandrins de perçage DIN 238



Verwendung:
Zur Aufnahme von Bohrfuttern.
Application:
For mounting drill chucks.
Application:
Pour le serrage de mandrins de perçage.

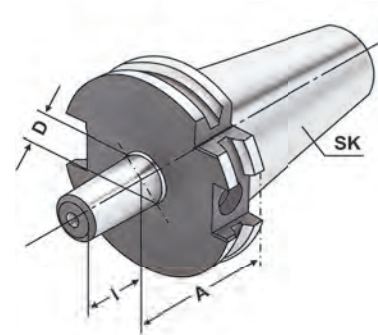

DIN 69871

Form A

 $\nabla \leq 0,005$ G6,3
15.000 min⁻¹

Bestell-Nr. Order no. Référence	SK	D	A	I
302.14.12	SK 30	B12	25	18,5
302.14.16	SK 30	B16	25	24
402.14.12	SK 40	B12	25	18,5
402.14.16	SK 40	B16	25	24
402.14.18	SK 40	B18	35	32
502.14.12	SK 50	B12	25	18,5
502.14.16	SK 50	B16	25	24
502.14.18	SK 50	B18	25	32



CNC-Drill chucks for clockwise and counter clockwise rotation Mandrins de perçage CNC pour rotation gauche-droite

1



Verwendung:
Zur Aufnahme von Werkzeugen mit Zylinderschaft.

Application:
For mounting tools with straight shanks.

Application:
Pour le serrage d'outils avec queue cylindrique.

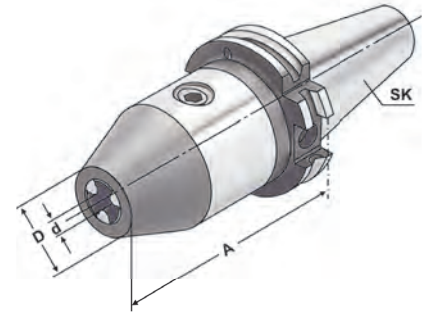

DIN 69871



AD

$\nabla \leq 0,030$

G6,3
15.000 min⁻¹



14.04

Bestell-Nr. Order no. Référence	SK	Spannbereich Capacity Capacité	A	D
302.15.08	SK 30	0 – 8	70	36
302.15.13	SK 30	1,0 – 13	111	50
302.15.16	SK 30	2,5 – 16	116	50
402.15.08	SK 40	0 – 8	70	36
402.15.13	SK 40	1,0 – 13	90	50
402.15.16	SK 40	2,5 – 16	95	50
502.15.13	SK 50	1,0 – 13	90	50
502.15.16	SK 50	2,5 – 16	95	50

Hinweis: Hohe Präzision und Rundlaufgenauigkeit von $\leq 0,03$ mm. Sichere Spannung des Werkzeuges durch mechanische Spannkraftverstärkung. Kein selbständiges Lösen der Spannung während der Bearbeitung bei Links- oder Rechtslauf, sowie bei Spindelstop. Spannen und Lösen mit Sechskantschlüssel.

Note: *High precision and accurate concentricity of ≤ 0.03 mm. Secure gripping of the tool through mechanical amplification of the clamping force. No automatic slackening of the clamping force while machining with either clockwise or counter clockwise rotation or on spindle stop. Clamping and releasing effected by means of an Allen wrench.*

Observation: Précision élevée et exactitude de circularité de $\leq 0,03$ mm. Serrage sûr de l'outil grâce à l'amplification de la force de serrage. Pas de desserrage intempestif en cours d'usinage lors de la rotation la gauche ou la droite, de même qu'en cas d'arrêt de la broche. Serrage et desserrage en utilisant un clé sur à fourche.

Lieferumfang: Mit Spannschlüssel
Delivery: With wrench
Livraison: Avec clé de serrage



10.23



10.24

CNC-Drill chucks for clockwise and counter clockwise rotation
Mandrins de perçage CNC pour rotation gauche-droite



Verwendung:
Zur Aufnahme von Werkzeugen mit Zylinderschaft.

Application:
For mounting tools with straight shanks.

Application:
Pour le serrage d'outils avec queue cylindrique.

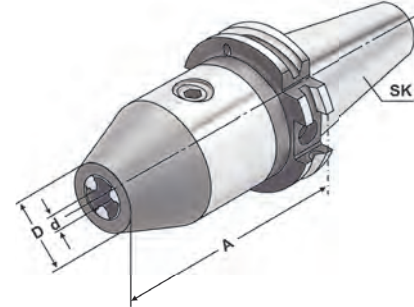

DIN 69871



AD/B

 $\nearrow \leq 0,030$
 $G6,3$
15.000 min⁻¹

14.04

Bestell-Nr. Order no. Référence	SK	Spannbereich Capacity Capacité	A	D
403.15.08	SK 40	0 – 8	70	36
403.15.13	SK 40	1,0 – 13	90	50
403.15.16	SK 40	2,5 – 16	95	50
503.15.13	SK 50	1,0 – 13	90	50
503.15.16	SK 50	2,5 – 16	95	50

Hinweis: Hohe Präzision und Rundlaufgenauigkeit von $\leq 0,03$ mm. Sichere Spannung des Werkzeuges durch mechanische Spannkraftverstärkung. Kein selbständiges Lösen der Spannung während der Bearbeitung bei Links- oder Rechtslauf, sowie bei Spindelstop. Spannen und Lösen mit Sechskantschlüssel.

Note: High precision and accurate concentricity of ≤ 0.03 mm. Secure gripping of the tool through mechanical amplification of the clamping force. No automatic slackening of the clamping force while machining with either clockwise or counter clockwise rotation or on spindle stop. Clamping and releasing effected by means of an Allen wrench.

Observation: Précision élevée et exactitude de circularité de $\leq 0,03$ mm. Serrage sûr de l'outil grâce à l'amplification de la force de serrage. Pas de desserrage intempestif en cours d'usinage lors de la rotation la gauche ou la droite, de même qu'en cas d'arrêt de la broche. Serrage et desserrage en utilisant un clé sur à fourche.

Lieferumfang: Mit Spannschlüssel
Delivery: With wrench
Livraison: Avec clé de serrage



10.23



10.24



mit Längenausgleich auf Druck und Zug

1

Quick change tapping chucks with length compensation on compression and expansion

Mandrins de taraudage à changement rapide avec compensation longitudinale à la compression et traction



Verwendung:
Zur Aufnahme von Schnellwechsel-Ein-sätzen für Gewindebohrer.

Application:
For the chucking of quick change adaptors for taps.

Application:
Pour le serrage d'adapteurs porte-tarands à changement rapide.

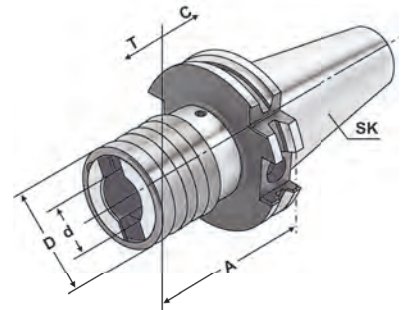

DIN 69871 Form A

14.04

Bestell-Nr. Order no. Référence	SK	Spannbereich Capacity Capacité	Größe Size Taille	A	D	d	T	C
302.16.12	SK 30	M3 - M14	1	65	36	19	7	7
302.16.20	SK 30	M5 - M22	2	102	53	31	12	12
402.16.12	SK 40	M3 - M14	1	63	36	19	7	7
402.16.20	SK 40	M5 - M22	2	97	53	31	12	12
402.16.36	SK 40	M14 - M36	3	156	78	48	17,5	17,5
502.16.12	SK 50	M3 - M14	1	63	36	19	7	7
502.16.20	SK 50	M5 - M22	2	97	53	31	12	12
502.16.36	SK 50	M14 - M36	3	140	78	48	17,5	17,5

Hinweis: Für Bearbeitungszentren ohne Synchronspindel.
Note: For machining centres without synchronous spindle.
Observation: Pour centres d'usinage sans broche synchrone.





ohne Längenausgleich auf Druck und Zug

Quick change tapping chucks **without** length compensation on compression and expansion
 Mandrins de taraudage à changement rapide **sans** compensation longitudinale à la compression et traction



Verwendung:
 Zur Aufnahme von Schnellwechsel-Einsätzen für Gewindebohrer.
Application:
 For the chucking of quick change adaptors for taps.
Application:
 Pour le serrage d'adaptateurs portetarauds à changement rapide.

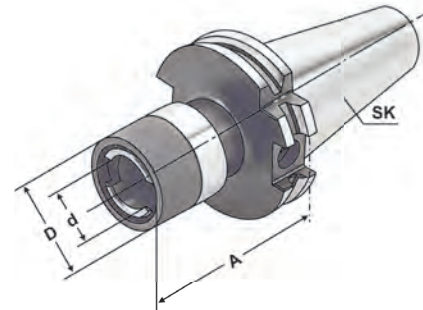

DIN 69871 AD

14.04

Bestell-Nr. Order no. Référence	SK	Spannbereich Capacity Capacité	Größe Size Taille	A	D	d
302.16.12.1	SK 30	M3 – M14	1	58	34	19
302.16.20.1	SK 30	M5 – M22	2	103	49	31
402.16.12.1	SK 40	M3 – M14	1	62	34	19
402.16.20.1	SK 40	M5 – M22	2	95	49	31
402.16.36.1	SK 40	M14 – M36	3	130	74	48
502.16.12.1	SK 50	M3 – M14	1	60	34	19
502.16.20.1	SK 50	M5 – M22	2	85	49	31
502.16.36.1	SK 50	M14 – M36	3	117	74	48

Hinweis: Für Bearbeitungszentren mit Synchronspindel.
Note: For machining centres with synchronous spindle.
Observation: Pour centres d'usinage avec broche synchrone.





für Spannzangen DIN 6499 (ISO 15488) System ER

Tapping chucks for synchronisation for collets DIN 6499 (ISO 15488) ER-system

Mandrins de taraudage pour synchronisation pour pinces DIN 6499 (ISO 15488) système ER

1

**Verwendung:**

Für Bearbeitungszentren mit Synchronspindel.

Application:

For machining centres with synchronous spindle.

Application:

Pour centres d'usinage avec broche synchrone.

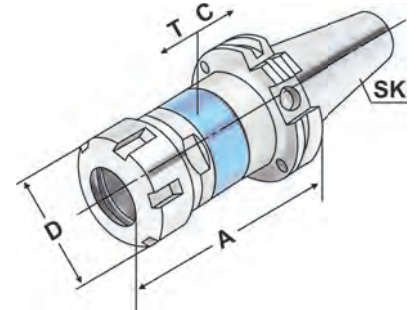

DIN 69871



AD/B

 $\gamma \leq 0,060$ G6,3
15.000 min⁻¹

14.04

Bestell-Nr. Order no. Référence	SK	Spannbereich Capacity Capacité	A	D	T	C
302.16.02.13 ¹	SK 30	M3 – M16 (ER 20)	85	34	0,5	0,5
403.16.02.10 ²	SK 40	M3 – M12 (ER 16) SW25	79	28	0,5	0,5
403.16.02.10.M ³	SK 40	M3 – M12 (ER 16) Mini	79	22	0,5	0,5
403.16.02.13	SK 40	M3 – M16 (ER 20)	80	34	0,5	0,5
403.16.02.16	SK 40	M3 – M20 (ER 25)	84	42	0,5	0,5
403.16.02.20	SK 40	M3 – M27 (ER 32)	95	50	0,5	0,5
403.16.02.26	SK 40	M3 – M33 (ER 40)	120	63	0,5	0,5
503.16.02.10 ²	SK 50	M3 – M12 (ER 16) SW25	79	28	0,5	0,5
503.16.02.10.M ³	SK 50	M3 – M12 (ER 16) Mini	79	22	0,5	0,5
503.16.02.10.1.M ³	SK 50	M3 – M12 (ER 16) Mini	90	22	0,5	0,5
503.16.02.13	SK 50	M3 – M16 (ER 20)	80	34	0,5	0,5
503.16.02.16	SK 50	M3 – M20 (ER 25)	84	42	0,5	0,5
503.16.02.20	SK 50	M3 – M27 (ER 32)	95	50	0,5	0,5
503.16.02.26	SK 50	M3 – M33 (ER 40)	105	63	0,5	0,5

¹ DIN 69871 Form AD¹ DIN 69871 form AD¹ DIN 69871 forme AD² Sechskantmutter² Hexagonal clamping nut² Écrous hexagonal³ Minimutter³ Mini nut³ Écrous mini**Hinweis:**

- Synchro-Gewindeschneidfutter kompensieren Synchronisationsfehler.
- Minimallängenausgleich in Druck- und Zugrichtung zwischen Synchronspindel und Gewindebohrer reduziert zu hohe Gewindeflankenreibungskräfte.
- Reduziert eventuelle Axialkraftehöhung während des Schneidzyklus auf ein Minimum.
- Geeignet für Innenkühlung.
- Kühlmitteldruck max. 100 bar.

Note:

- *Synchro tapping chucks compensate synchronisation errors.*
- *Minimal length compensation on compression and expansion balances very small pitch differences between synchro spindle and tap, which can cause high frictional forces on the thread flanks.*
- *A possible increase of axial force during the tapping process is reduced to a minimum.*
- *Suitable for internal coolant.*
- *Coolant pressure up to max. 100 bar.*

Observation:

- Mandrins de taraudage version „synchro“ compensent les erreurs éventuelles de synchronisation.
- Compensation longitudinale minimale à la compression et traction entre la broche synchronisée et le taraud réduit la friction au niveau des flancs de filets.
- Réduit au minimum les efforts éventuelles axiaux lors du cycle de taraudage.
- Approprié pour la lubrification centrale.
- Pression de lubrification max. 100 bar.

Lieferumfang:

Mit gewuchteter Spannmutter

Delivery:

With balanced clamping nut

Livraison:

Avec écrou de serrage équilibré



9.03



10.22



10.39



10.24

Boring bar blanks
Barres d'alésage



Verwendung:
Zur Herstellung von Sonderwerkzeugen.
Application:
For the manufacturing of special tools.
Application:
Pour la fabrication d'outils spéciaux.

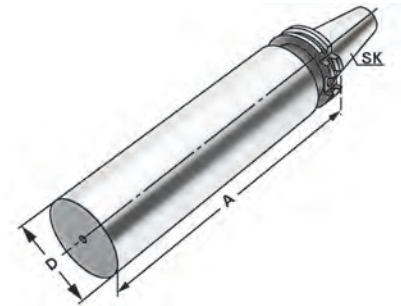

DIN 69871

Form A

Bestell-Nr. Order no. Référence	SK	D	A
302.17.40	SK 30	40,5	160
402.17.63	SK 40	63	250
502.17.97	SK 50	97	315

Ausführung: Steilkegel und Bund gehärtet und geschliffen. Schaft weich zur weiteren Bearbeitung.
Version: Cone and flange hardened and grinded. Soft body for later processing.
Version: Cône et collerette durcis et rectifiés. Corps doux pour un usinage ultérieur.

Gewuchtete Ausführung

Balanced type
Type équilibré



Bestell-Nr. Order no. Référence	Abmessung Size Dimension
---------------------------------------	--------------------------------

Wuchten auf G 2,5 von vorgewuchteten Kemmler-Werkzeugen

Balancing at G 2.5 of pre-balanced Kemmler-tools
Équilibrage sur G 2,5 d'outils Kemmler pré-équilibrés

W25 **Ohne Wuchtprotokoll**
Without balancing report
Sans protocole d'équilibrage

W25.2 **Mit Wuchtprotokoll**
With balancing report
Avec protocole d'équilibrage

Wuchten von nicht vorgewuchteten Werkzeugen
Balancing of unbalanced tools
Équilibrage d'outils non-équilibrés

W25.1 **Ohne Wuchtprotokoll**
Without balancing report
Sans protocole d'équilibrage



10.24

Test arbors
Mandrins de contrôle

1



Verwendung:
Zur Abnahme von Werkzeugmaschinen gemäß ISO-Empfehlung R230 oder zur Überprüfung der Werkzeugspindel.

Application:
For the inspection of machine tools according to ISO recommendation R230 or for testing the tool spindle.

Application:
Pour l'inspection de machine-outils suite à la recommandation ISO R230 ou pour la vérification de la broche.

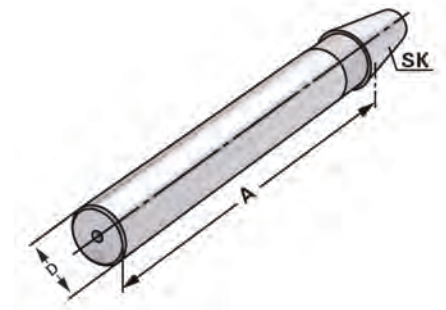

DIN 69871

Form A

$\nabla \leq 0,003$

Bestell-Nr. Order no. Référence	SK	A	D	Toleranz Tolerance Tolérance	max. Rundlaufabweichung max. concentricity deviation Faux-rond max.
302.18.32	SK 30	300	32	0,003	0,003
402.18.40	SK 40	300	40	0,003	0,003
502.18.50	SK 50	300	50	0,003	0,003

Lieferumfang: Auslieferung mit Prüfprotokoll
Delivery: Delivery with test certificate
Livraison: Livraison avec rapport d'essais

Holzkasten für Kontrolldorne

Wooden box for test arbors
Coffret en bois pour mandrins de contrôle



Verwendung:
Zur Aufbewahrung von Kontrolldornen.

Application:
For the storage of test arbors.

Application:
Pour la conservation de mandrins de contrôle.



Bestell-Nr. Order no. Référence	Abmessung Size Dimension	für Kegelgrößen for cones pour cônes
701.18	460 × 130 × 115	SK 30 / 40 / 50



10.24

Hydraulic expansion chucks
Mandrins expansibles hydrauliques



Verwendung:
Zur Aufnahme von Werkzeugen mit Zylinderschaft nach DIN 1835 Form A+B+E und DIN 6535 Form HB+HE (größer Ø 20 mm nur mit Reduzierung).

Application:
For mounting straight-shank tools acc. DIN 1835 form A+B+E and DIN 6535 form HB+HE (larger than Ø 20 mm only with reduction sleeve).

Application:
Pour le serrage d'outils avec queue cylindrique suivant DIN 1835 forme A+B+E et DIN 6535 forme HB+HE (à partir de Ø 20 mm seulement avec réduction).

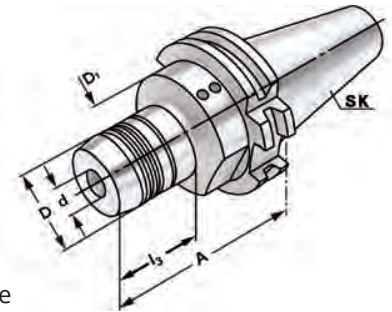

DIN 69871 AD/B $\sqrt{\leq 0,003}$ G6,3 15.000 min⁻¹ 14.04

Bestell-Nr. Order no. Référence	SK	d	A	D	D ₁	l ₁	l ₂	l ₃
302.H06*	SK 30	6	60	26	45	37	10	25
302.H08*	SK 30	8	64	28	45	37	10	29
302.H10*	SK 30	10	64	30	45	42	10	35
302.H12*	SK 30	12	72	32	45	47	10	43
302.H14*	SK 30	14	72	34	45	47	10	42
302.H16*	SK 30	16	72	38	45	52	10	43
302.H18*	SK 30	18	72	40	45	52	10	43
302.H20*	SK 30	20	90	42	42	52	10	71
403.H06	SK 40	6	68	26	50	37	10	33
403.H08	SK 40	8	68	28	50	37	10	33
403.H10	SK 40	10	72	30	50	42	10	37
403.H12	SK 40	12	77	32	50	47	10	42
403.H14	SK 40	14	77	34	50	47	10	42
403.H16	SK 40	16	80	38	50	52	10	43
403.H18	SK 40	18	80	40	50	52	10	43
403.H20	SK 40	20	82	42	50	52	10	47
403.H25	SK 40	25	117	50	63	58	10	51
403.H32	SK 40	32	117	60	63	62	10	56
403.H06.1	SK 40	6	110	26	50	37	10	33
403.H08.1	SK 40	8	110	28	50	37	10	33
403.H10.1	SK 40	10	110	30	50	42	10	37
403.H12.1	SK 40	12	110	32	50	47	10	42
403.H14.1	SK 40	14	110	34	50	47	10	42
403.H16.1	SK 40	16	110	38	50	52	10	42
403.H18.1	SK 40	18	110	40	50	52	10	47
403.H20.1	SK 40	20	110	42	50	52	10	47

* DIN 69871 Form AD
* DIN 69871 form AD
* DIN 69871 forme AD

Lieferumfang: Mit Spannschlüssel
Delivery: With wrench
Livraison: Avec clé de serrage

l₁ = max. Einstecktiefe
l₁ = max. clamping depth
l₁ = max. profondeur d'insertion

l₂ = max. Verstellweg
l₂ = max. length adjustment range
l₂ = max. course de réglage

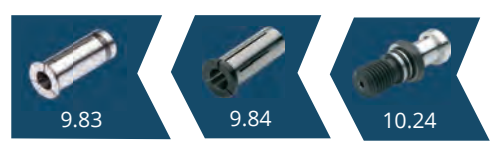



Hydraulic expansion chucks
Mandrins expansibles hydrauliques

1



Verwendung:
Zur Aufnahme von Werkzeugen mit Zylinderschaft nach DIN 1835 Form A+B+E und DIN 6535 Form HB+HE (größer Ø 20 mm nur mit Reduzierung).

Application:
For mounting straight-shank tools acc. DIN 1835 form A+B+E and DIN 6535 form HB+HE (larger than Ø 20 mm only with reduction sleeve).

Application:
Pour le serrage d'outils avec queue cylindrique suivant DIN 1835 forme A+B+E et DIN 6535 forme HB+HE (à partir de Ø 20 mm seulement avec réduction).

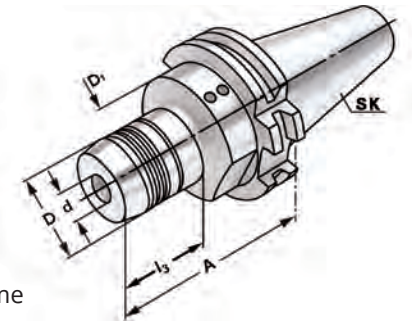

DIN 69871



AD/B

$\nabla \leq 0,003$

G6,3
15.000 min⁻¹



14.04

Bestell-Nr. Order no. Référence	SK	d	A	D	D ₁	l ₁	l ₂	l ₃
503.H06	SK 50	6	68	26	80	37	10	33
503.H08	SK 50	8	68	28	80	37	10	33
503.H10	SK 50	10	72	30	80	42	10	37
503.H12	SK 50	12	77	32	80	47	10	42
503.H14	SK 50	14	77	34	80	47	10	42
503.H16	SK 50	16	80	38	80	52	10	45
503.H18	SK 50	18	80	40	80	52	10	45
503.H20	SK 50	20	82	42	80	52	10	47
503.H25	SK 50	25	87	50	80	58	10	52
503.H32	SK 50	32	91	60	80	62	10	56
503.H06.1	SK 50	6	110	26	50	91	10	33
503.H08.1	SK 50	8	110	28	50	91	10	33
503.H10.1	SK 50	10	110	30	50	91	10	37
503.H12.1	SK 50	12	110	32	50	91	10	42
503.H14.1	SK 50	14	110	34	50	91	10	42
503.H16.1	SK 50	16	110	38	50	91	10	42
503.H18.1	SK 50	18	110	40	50	91	10	47
503.H20.1	SK 50	20	110	42	50	91	10	47
503.H25.1	SK 50	25	110	50	80	91	10	47
503.H32.1	SK 50	32	110	60	80	91	10	75
503.H06.2	SK 50	6	150	26	50	37	10	115
503.H08.2	SK 50	8	150	28	50	37	10	115
503.H10.2	SK 50	10	150	30	50	42	10	115
503.H12.2	SK 50	12	150	32	50	42	10	115
503.H14.2	SK 50	14	150	34	50	47	10	115
503.H16.2	SK 50	16	150	38	50	52	10	115
503.H18.2	SK 50	18	150	40	50	52	10	115
503.H20.2	SK 50	20	150	42	50	52	10	115
503.H25.2	SK 50	25	150	50	50	52	10	131
503.H32.2	SK 50	32	150	60	60	62	10	131
503.H40.2	SK 50	40	150	70	70	72	10	131

Lieferumfang: Mit Spannschlüssel
Delivery: With wrench
Livraison: Avec clé de serrage

l₁ = max. Einstecktiefe l₂ = max. Verstellweg
l₁ = max. clamping depth l₂ = max. length adjustment range
l₁ = max. profondeur d'insertion l₂ = max. course de réglage

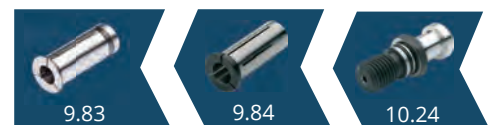

zum Spannen von HM und HSS Werkzeugschäften

Shrink chucks 4,5° for mounting of solid carbide and HSS-tool shanks

Mandrins de frettage 4,5° pour le serrage de queues d'outils carbures de type HM et HSS



Verwendung:
Zur Aufnahme von Werkzeugen mit Zylinderschaft.

Application:
For mounting straight-shank tools.

Application:
Pour le serrage d'outils avec queue cylindrique.

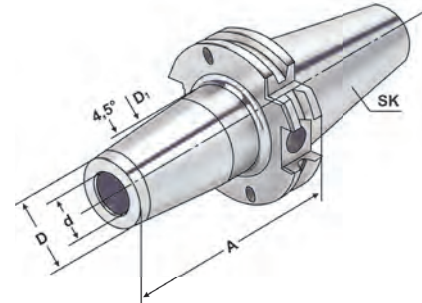

DIN 69871



AD

 $\nabla \leq 0,003$
 $G2.5$
25.000 min⁻¹

Bestell-Nr. Order no. Référence	SK	d	A	D	D ₁	l ₁	l ₂
302.70.03	SK 30	3	80	11	15	10	-
302.70.04	SK 30	4	80	14	22	20	5
302.70.05	SK 30	5	80	16	22	20	5
302.70.06	SK 30	6	80	21	27	36	10
302.70.08	SK 30	8	80	21	27	36	10
302.70.10	SK 30	10	80	24	32	41	10
302.70.12	SK 30	12	100	24	32	47	10
302.70.14	SK 30	14	100	27	34	47	10
302.70.16	SK 30	16	100	27	34	50	10
302.70.18	SK 30	18	100	33	42	50	10
302.70.20	SK 30	20	100	33	42	52	10
302.70.03.1	SK 30	3	160	11	15	10	-
302.70.04.1	SK 30	4	160	14	22	20	5
302.70.05.1	SK 30	5	160	16	22	20	5
302.70.06.1	SK 30	6	160	21	27	36	10
302.70.08.1	SK 30	8	160	21	27	36	10
302.70.10.1	SK 30	10	160	24	32	41	10
302.70.12.1	SK 30	12	160	24	32	47	10
302.70.14.1	SK 30	14	160	27	34	47	10
302.70.16.1	SK 30	16	160	27	34	50	10
302.70.18.1	SK 30	18	160	33	42	50	10
302.70.20.1	SK 30	20	160	33	42	52	10

Für Ø 3, 4 und 5 mm nur Hartmetallschäfte verwenden

For Ø 3, 4 and 5 mm only solid carbide tool shanks must be used

Pour Ø 3, 4 et 5 mm il faut seulement utiliser de queues d'outils carbures de type HM

Hinweis: Aufnahmen für Induktiv-, Kontakt- und Heißluftschumpfgeräte geeignet.
Schafttoleranz bei Ø 3, 4 und 5 mm = h₄, bei Ø 6 - Ø 32 mm = h₆

Note: Toolholders suitable for induction-, contact- and hot air shrink units.
Ø 3, 4, 5 with h₄-tolerance and Ø 6 - Ø 32 with h₆-tolerance

Observation: Porte-outils convenables pour machines à fretter par induction, par contact, ou par air chaud.
Ø 3, 4, 5 avec h₄-tolerance et Ø 6 - Ø 32 avec h₆-tolerance

l₁ = max. Einstecktiefel₁ = max. clamping depthl₁ = max. profondeur d'insertion**l₂ = max. Verstellweg**l₂ = max. length adjustment rangel₂ = max. course de réglage



zum Spannen von HM und HSS Werkzeugschäften

Shrink chucks 4,5° for mounting of solid carbide and HSS-tool shanks

Mandrins de frettage 4,5° pour le serrage de queues d'outils carbures de type HM et HSS

1

**Verwendung:**

Zur Aufnahme von Werkzeugen mit Zylinderschaft.

Application:

For mounting straight-shank tools.

Application:

Pour le serrage d'outils avec queue cylindrique.

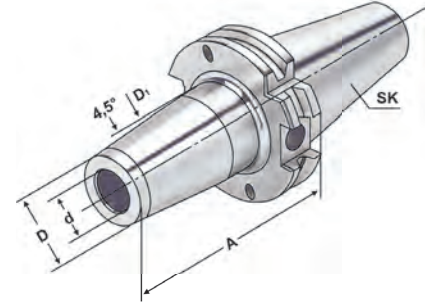

DIN 69871



AD/B

 $\gamma \leq 0,003$ G2.5
25.000 min⁻¹

Bestell-Nr. Order no. Référence	SK	d	A	D	D ₁	l ₁	l ₂
403.70.03	SK 40	3	80	11	15	10	-
403.70.04	SK 40	4	80	14	22	20	5
403.70.05	SK 40	5	80	16	22	20	5
403.70.06	SK 40	6	80	21	27	36	10
403.70.08	SK 40	8	80	21	27	36	10
403.70.10	SK 40	10	80	24	32	41	10
403.70.12	SK 40	12	80	24	32	47	10
403.70.14	SK 40	14	80	27	34	47	10
403.70.16	SK 40	16	80	27	34	50	10
403.70.18	SK 40	18	80	33	42	50	10
403.70.20	SK 40	20	80	33	42	52	10
403.70.25	SK 40	25	100	44	53	58	10
403.70.32	SK 40	32	100	44	53	62	10
403.70.03.1	SK 40	3	120	11	15	10	-
403.70.04.1	SK 40	4	120	14	22	20	5
403.70.05.1	SK 40	5	120	16	22	20	5
403.70.06.1	SK 40	6	120	21	27	36	10
403.70.08.1	SK 40	8	120	21	27	36	10
403.70.10.1	SK 40	10	120	24	32	41	10
403.70.12.1	SK 40	12	120	24	32	47	10
403.70.14.1	SK 40	14	120	27	34	47	10
403.70.16.1	SK 40	16	120	27	34	50	10
403.70.18.1	SK 40	18	120	33	42	50	10
403.70.20.1	SK 40	20	120	33	42	52	10
403.70.25.1	SK 40	25	120	44	53	58	10
403.70.32.1	SK 40	32	120	44	53	62	10

Für Ø 3, 4 und 5 mm nur Hartmetallschäfte verwenden

For Ø 3, 4 and 5 mm only solid carbide tool shanks must be used

Pour Ø 3, 4 et 5 mm il faut seulement utiliser de queues d'outils carbures de type HM

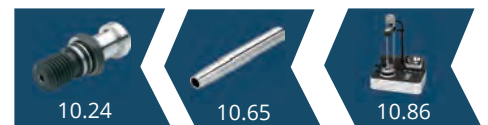
Hinweis:Aufnahmen für Induktiv-, Kontakt- und Heißluftschumpfergeräte geeignet.
Schafttoleranz bei Ø 3, 4 und 5 mm = h4, bei Ø 6 - Ø 32 mm = h6**Note:**Toolholders suitable for induction-, contact- and hot air shrink units.
Ø 3, 4, 5 with h4-tolerance and Ø 6 - Ø 32 with h6-tolerance**Observation:**Porte-outils convenables pour machines à fretter par induction, par contact, ou par air chaud.
Ø 3, 4, 5 avec h4-tolerance et Ø 6 - Ø 32 avec h6-tolerance**l₁ = max. Einstecktiefe**l₁ = max. clamping depthl₁ = max. profondeur d'insertion**l₂ = max. Verstellweg**l₂ = max. length adjustment rangel₂ = max. course de réglage

zum Spannen von HM und HSS Werkzeugschäften

Shrink chucks 4,5° for mounting of solid carbide and HSS-tool shanks

Mandrins de frettage 4,5° pour le serrage de queues d'outils carbures de type HM et HSS



Verwendung:
Zur Aufnahme von Werkzeugen mit Zylinderschaft.

Application:
For mounting straight-shank tools.

Application:
Pour le serrage d'outils avec queue cylindrique.

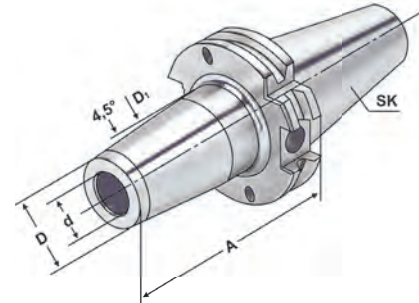

DIN 69871



AD/B

 $\gamma \leq 0,003$
 $G2.5$
25.000 min⁻¹

Bestell-Nr.
Order no.
Référence

SK

d

A

D

D₁l₁l₂

403.70.03.2

SK 40

3

160

11

15

10

10

403.70.04.2

SK 40

4

160

14

22

20

10

403.70.05.2

SK 40

5

160

16

22

20

10

403.70.06.2

SK 40

6

160

21

27

36

10

403.70.08.2

SK 40

8

160

21

27

36

10

403.70.10.2

SK 40

10

160

24

32

41

10

403.70.12.2

SK 40

12

160

24

32

47

10

403.70.14.2

SK 40

14

160

27

34

47

10

403.70.16.2

SK 40

16

160

27

34

50

10

403.70.18.2

SK 40

18

160

33

42

50

10

403.70.20.2

SK 40

20

160

33

42

52

10

403.70.25.2

SK 40

25

160

44

53

58

10

403.70.32.2

SK 40

32

160

44

53

62

10

Für Ø 3, 4 und 5 mm nur Hartmetallschäfte verwenden

For Ø 3, 4 and 5 mm only solid carbide tool shanks must be used

Pour Ø 3, 4 et 5 mm il faut seulement utiliser de queues d'outils carbures de type HM

Hinweis: Aufnahmen für Induktiv-, Kontakt- und Heißluftschumpfergeräte geeignet.
Schafttoleranz bei Ø 3, 4 und 5 mm = h₄, bei Ø 6 – Ø 32 mm = h₆

Note: Toolholders suitable for induction-, contact- and hot air shrink units.
Ø 3, 4, 5 with h₄-tolerance and Ø 6 – Ø 32 with h₆-tolerance

Observation: Porte-outils convenables pour machines à frotter par induction, par contact, ou par air chaud.
Ø 3, 4, 5 avec h₄-tolerance et Ø 6 – Ø 32 avec h₆-tolerance

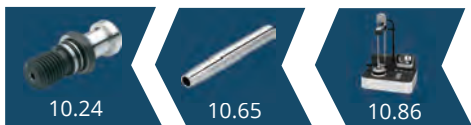
l₁ = max. Einstecktiefel₁ = max. clamping depthl₁ = max. profondeur d'insertion**l₂ = max. Verstellweg**l₂ = max. length adjustment rangel₂ = max. course de réglage



zum Spannen von HM und HSS Werkzeugschäften

Shrink chucks 4,5° for mounting of solid carbide and HSS-tool shanks

Mandrins de frettage 4,5° pour le serrage de queues d'outils carbures de type HM et HSS

1

**Verwendung:**

Zur Aufnahme von Werkzeugen mit Zylinderschaft.

Application:

For mounting straight-shank tools.

Application:

Pour le serrage d'outils avec queue cylindrique.

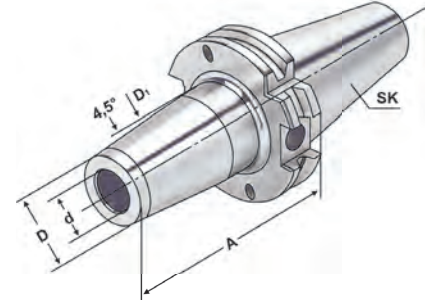

DIN 69871



AD/B

 $\lambda \leq 0,003$ G2.5
25.000 min⁻¹

Bestell-Nr. Order no. Référence	SK	d	A	D	D ₁	l ₁	l ₂
503.71.03	SK 50	3	80	11	15	10	10
503.71.04	SK 50	4	80	14	22	20	10
503.71.05	SK 50	5	80	16	22	20	10
503.71.06	SK 50	6	80	21	27	36	10
503.71.08	SK 50	8	80	21	27	36	10
503.71.10	SK 50	10	80	24	32	41	10
503.71.12	SK 50	12	80	24	32	47	10
503.71.14	SK 50	14	80	27	34	47	10
503.71.16	SK 50	16	80	27	34	50	10
503.71.18	SK 50	18	80	33	42	50	10
503.71.20	SK 50	20	80	33	42	52	10
503.71.25	SK 50	25	100	44	53	58	10
503.71.32	SK 50	32	100	44	53	62	10
503.71.06.1	SK 50	6	120	21	27	36	10
503.71.08.1	SK 50	8	120	21	27	36	10
503.71.10.1	SK 50	10	120	24	32	41	10
503.71.12.1	SK 50	12	120	24	32	47	10
503.71.14.1	SK 50	14	120	27	34	47	10
503.71.16.1	SK 50	16	120	27	34	50	10
503.71.18.1	SK 50	18	120	33	42	50	10
503.71.20.1	SK 50	20	120	33	42	52	10

Für Ø 3, 4 und 5 mm nur Hartmetallschäfte verwenden

For Ø 3, 4 and 5 mm only solid carbide tool shanks must be used

Pour Ø 3, 4 et 5 mm il faut seulement utiliser de queues d'outils carbures de type HM

Hinweis:Aufnahmen für Induktiv-, Kontakt- und Heißluftschumpfgeräte geeignet.
Schafttoleranz bei Ø 6 - Ø 32 mm = h₆**Note:**Toolholders suitable for induction-, contact- and hot air shrink units.
Ø 6 - Ø 32 with h₆-tolerance**Observation:**Porte-outils convenables pour machines à fretter par induction,
par contact, ou par air chaud.
Ø 6 - Ø 32 avec h₆-tolerance

10.24

10.65

10.86

l₁ = max. Einstecktiefel₁ = max. clamping depthl₁ = max. profondeur d'insertion**l₂ = max. Verstellweg**l₂ = max. length adjustment rangel₂ = max. course de réglage

zum Spannen von HM und HSS Werkzeugschäften

Shrink chucks 4,5° for mounting of solid carbide and HSS-tool shanks
Mandrins de frettage 4,5° pour le serrage de queues d'outils carbures de type HM et HSS



Verwendung:
Zur Aufnahme von Werkzeugen mit Zylinderschaft.
Application:
For mounting straight-shank tools.
Application:
Pour le serrage d'outils avec queue cylindrique.

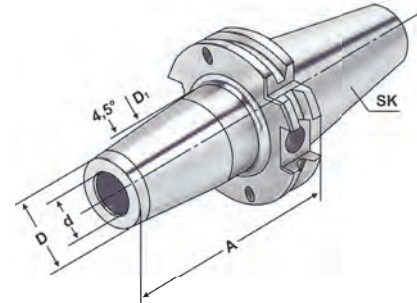

DIN 69871 AD/B $\sqrt{\text{Ra}} \leq 0,003$ G2.5 25.000 min⁻¹

Bestell-Nr. Order no. Référence	SK	d	A	D	D ₁	l ₁	l ₂
503.71.06.2	SK 50	6	160	21	27	36	10
503.71.08.2	SK 50	8	160	21	27	36	10
503.71.10.2	SK 50	10	160	24	32	41	10
503.71.12.2	SK 50	12	160	24	32	47	10
503.71.14.2	SK 50	14	160	27	34	47	10
503.71.16.2	SK 50	16	160	27	34	50	10
503.71.18.2	SK 50	18	160	33	42	50	10
503.71.20.2	SK 50	20	160	33	42	52	10
503.71.25.2	SK 50	25	160	44	53	58	10
503.71.32.2	SK 50	32	160	44	53	62	10
503.71.06.3	SK 50	6	200	21	27	36	10
503.71.08.3	SK 50	8	200	21	27	36	10
503.71.10.3	SK 50	10	200	24	32	41	10
503.71.12.3	SK 50	12	200	24	32	47	10
503.71.14.3	SK 50	14	200	27	34	47	10
503.71.16.3	SK 50	16	200	27	34	50	10
503.71.18.3	SK 50	18	200	33	42	50	10
503.71.20.3	SK 50	20	200	33	42	52	10
503.71.25.3	SK 50	25	200	44	53	58	10
503.71.32.3	SK 50	32	200	44	53	62	10

Für Ø 3, 4 und 5 mm nur Hartmetallschäfte verwenden
For Ø 3, 4 and 5 mm only solid carbide tool shanks must be used
Pour Ø 3, 4 et 5 mm il faut seulement utiliser de queues d'outils carbures de type HM

Hinweis: Aufnahmen für Induktiv-, Kontakt- und Heißluftschumpfgeräte geeignet.
Schafttoleranz bei Ø 6 - Ø 32 mm = h₆

Note: Toolholders suitable for induction-, contact- and hot air shrink units.
Ø 6 - Ø 32 with h₆-tolerance

Observation: Porte-outils convenables pour machines à fretter par induction, par contact, ou par air chaud.
Ø 6 - Ø 32 avec h₆-tolerance

l₁ = max. Einstecktiefe **l₂ = max. Verstellweg**
l₁ = max. clamping depth l₂ = max. length adjustment range
l₁ = max. profondeur d'insertion l₂ = max. course de réglage

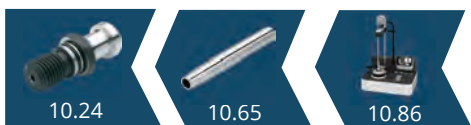



zum Spannen von HM und HSS Werkzeugschäften

Shrink chucks 4,5° for mounting of solid carbide and HSS-tool shanks

Mandrins de frettage 4,5° pour le serrage de queues d'outils carbures de type HM et HSS

1



Verwendung:
Zur Aufnahme von Werkzeugen mit Zylinderschaft.

Application:
For mounting straight-shank tools.

Application:
Pour le serrage d'outils avec queue cylindrique.

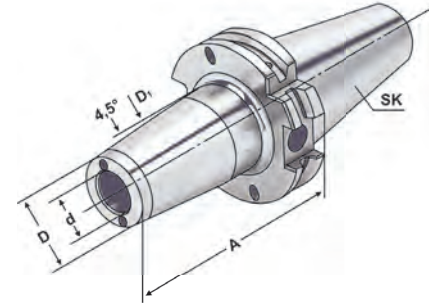

DIN 69871



AD/B

 $\nabla \leq 0,003$ G2,5
25.000 min⁻¹

Bestell-Nr. Order no. Référence	SK	d	A	D	D ₁	l ₁	l ₂
403.70.06.K	SK 40	6	80	21	27	36	10
403.70.08.K	SK 40	8	80	21	27	36	10
403.70.10.K	SK 40	10	80	24	32	41	10
403.70.12.K	SK 40	12	80	24	32	47	10
403.70.14.K	SK 40	14	80	27	34	47	10
403.70.16.K	SK 40	16	80	27	34	50	10
403.70.18.K	SK 40	18	80	33	42	50	10
403.70.20.K	SK 40	20	80	33	42	52	10
403.70.25.K	SK 40	25	100	44	53	58	10
403.70.32.K	SK 40	32	100	44	53	62	10
403.70.06.1.K	SK 40	6	120	21	27	36	10
403.70.08.1.K	SK 40	8	120	21	27	36	10
403.70.10.1.K	SK 40	10	120	24	32	41	10
403.70.12.1.K	SK 40	12	120	24	32	47	10
403.70.14.1.K	SK 40	14	120	27	34	47	10
403.70.16.1.K	SK 40	16	120	27	34	50	10
403.70.18.1.K	SK 40	18	120	33	42	50	10
403.70.20.1.K	SK 40	20	120	33	42	52	10
503.71.06.K	SK 50	6	80	21	27	36	10
503.71.08.K	SK 50	8	80	21	27	36	10
503.71.10.K	SK 50	10	80	24	32	41	10
503.71.12.K	SK 50	12	80	24	32	47	10
503.71.14.K	SK 50	14	80	27	34	47	10
503.71.16.K	SK 50	16	80	27	34	50	10
503.71.18.K	SK 50	18	80	33	42	50	10
503.71.20.K	SK 50	20	80	33	42	52	10
503.71.25.K	SK 50	25	100	44	53	58	10
503.71.32.K	SK 50	32	100	44	53	62	10

Für Ø 3, 4 und 5 mm nur Hartmetallschäfte verwenden

For Ø 3, 4 and 5 mm only solid carbide tool shanks must be used

Pour Ø 3, 4 et 5 mm il faut seulement utiliser de queues d'outils carbures de type HM



10.24



10.65



10.86

l₁ = max. Einstecktiefel₁ = max. clamping depthl₁ = max. profondeur d'insertion**l₂ = max. Verstellweg**l₂ = max. length adjustment rangel₂ = max. course de réglage

zum Spannen von HM und HSS Werkzeugschäften

Shrink chucks 3° for mounting of solid carbide and HSS-tool shanks - slim

Mandrins de frettage 3° pour le serrage de queues d'outils carbures de type HM et HSS - élané



Verwendung:
Zur Aufnahme von Werkzeugen mit Zylinderschaft.

Application:
For mounting straight-shank tools.

Application:
Pour le serrage d'outils avec queue cylindrique.

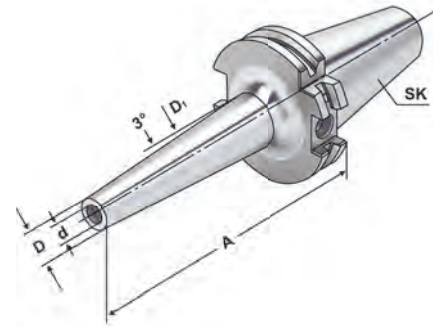

DIN 69871

 $\gamma \leq 0,003$ G2,5
25.000 min⁻¹

Bestell-Nr. Order no. Référence	SK	d	A	D	D ₁	l ₁	l ₂
403.72.03	SK 40	3	80	9	15,5	6	-
403.72.04	SK 40	4	80	10	16,5	8	-
403.72.05	SK 40	5	80	11	17,5	10	-
403.72.06	SK 40	6	80	12	18,5	36	10
403.72.08	SK 40	8	80	14	20,5	36	10
403.72.10	SK 40	10	80	16	22,5	42	10
403.72.12	SK 40	12	80	18	24,5	47	10
403.72.03.1	SK 40	3	120	9	19,5	6	-
403.72.04.1	SK 40	4	120	10	20,5	8	-
403.72.05.1	SK 40	5	120	11	21,5	10	-
403.72.06.1	SK 40	6	120	12	22,5	36	10
403.72.08.1	SK 40	8	120	14	24,5	36	10
403.72.10.1	SK 40	10	120	16	26,5	42	10
403.72.12.1	SK 40	12	120	18	28,5	47	10
403.72.06.2	SK 40	6	160	12	26,5	36	10
403.72.08.2	SK 40	8	160	14	28,5	36	10
403.72.10.2	SK 40	10	160	16	30,5	42	10
403.72.12.2	SK 40	12	160	18	32,5	47	10

Ausführung: schlanke Bauform (reduzierte Störkontur)
Version: slim design (reduced interference contour)
Version: Modèle très étroit (encombrement réduit)

Für Ø 3, 4 und 5 mm nur Hartmetallschäfte verwenden
 For Ø 3, 4 and 5 mm only solid carbide tool shanks must be used
 Pour Ø 3, 4 et 5 mm il faut seulement utiliser de queues d'outils carbures de type HM

Hinweis: Aufnahmen für Induktiv-, Kontakt- und Heißluftschumpfergeräte geeignet.
 Schafttoleranz bei Ø 3, 4 und 5 mm = h4, bei Ø 6 - Ø 12 mm = h6

Note: Toolholders suitable for induction-, contact- and hot air shrink units.
 Ø 3, 4, 5 with h4-tolerance and Ø 6 - Ø 12 with h6-tolerance

Observation: Porte-outils convenables pour machines à frotter par induction,
 par contact, ou par air chaud.
 Ø 3, 4, 5 avec h4-tolerance et Ø 6 - Ø 12 avec h6-tolerance

l₁ = max. Einstecktiefel₁ = max. clamping depthl₁ = max. profondeur d'insertion**l₂ = max. Verstellweg**l₂ = max. length adjustment rangel₂ = max. course de réglage

Shrink fit extensions (with end stop)
Rallonges de frettage (avec butée)

1



Verwendung:
Zur Aufnahme von Werkzeugen mit Zylinderschaft.

Application:
For mounting straight-shank tools.

Application:
Pour le serrage d'outils avec queue cylindrique.

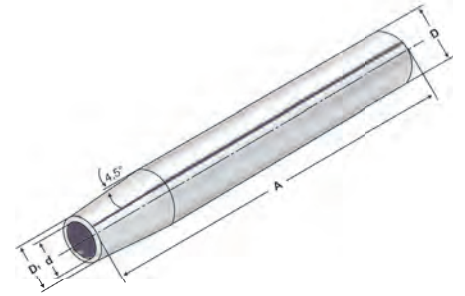

AD $\nearrow \leq 0,003$

Bestell-Nr. Order no. Référence	D	d	D ₁	A	l ₁	l ₂
120.70.03	20	3	10	150	15	5
120.70.04	20	4	10	150	20	5
120.70.05	20	5	10	150	20	5
120.70.06*	20	6	10	150	36	10
120.70.08*	20	8	12	150	36	10
120.70.10*	20	10	14	150	42	10
120.70.12*	20	12	16	150	47	10

* mit Anschlag | * with end stop | * avec butée

Für Ø 3, 4 und 5 mm nur Hartmetallschäfte verwenden!
For Ø 3, 4 and 5 mm only solid carbide tool shanks must be used!
Pour Ø 3, 4 et 5 mm il faut seulement utiliser de queues d'outils carbures de type HM!

Hinweis: Aufnahmen für Induktiv-, Kontakt- und Heißluftschumpfergeräte geeignet.
Schafftoleranz bei Ø 3, 4 und 5 mm = h₄, bei Ø 6 – Ø 32 mm = h₆

Note: *Toolholders suitable for induction-, contact- and hot air shrink units.*
Ø 3, 4, 5 with h₄-tolerance and Ø 6 – Ø 32 with h₆-tolerance

Observation: Porte-outils convenables pour machines à fretter par induction, par contact, ou par air chaud.
Ø 3, 4, 5 avec h₄-tolerance et Ø 6 – Ø 32 avec h₆-tolerance

l₁ = max. Einstecktiefe l₂ = max. Verstellweg
l₁ = max. clamping depth l₂ = max. length adjustment range
l₁ = max. profondeur d'insertion l₂ = max. course de réglage



Milling arbors for screw-in cutters
 Porte-fraises pour fraises à queue fileté



Verwendung:
 Zur Aufnahme von Einschraubfräser mit Gewinde.

Application:
 For mounting screw-in cutters with thread.

Application:
 Pour le serrage de fraises à queue fileté.

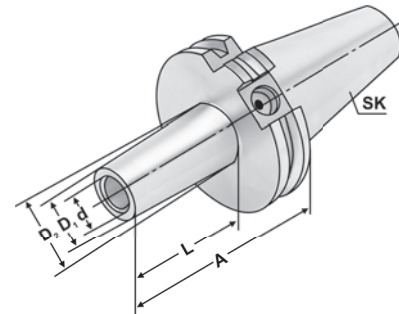

DIN 69871

 $\nabla \leq 0,003$ G6,3
15.000 min⁻¹

Bestell-Nr. Order no. Référence	SK	M	d ^{H4}	D ₁	D ₂	A	L
403.06.06	SK 40	6	6,5	10	13	44	25
403.06.06.1	SK 40	6	6,5	10	13	69	50
403.06.06.2	SK 40	6	6,5	10	13	94	75
403.06.08	SK 40	8	8,5	13	15	44	25
403.06.08.1	SK 40	8	8,5	13	23	69	50
403.06.08.2	SK 40	8	8,5	13	23	94	75
403.06.08.3	SK 40	8	8,5	13	25	119	100
403.06.10.0	SK 40	10	10,5	18	18	24	5
403.06.10	SK 40	10	10,5	18	20	44	25
403.06.10.1	SK 40	10	10,5	18	23	69	50
403.06.10.2	SK 40	10	10,5	18	28	94	75
403.06.10.3	SK 40	10	10,5	18	32	119	100
403.06.10.5	SK 40	10	10,5	18	37	169	150
403.06.12.0	SK 40	12	12,5	21	21	24	5
403.06.12	SK 40	12	12,5	21	24	44	25
403.06.12.1	SK 40	12	12,5	21	24	69	50
403.06.12.2	SK 40	12	12,5	21	31	94	75
403.06.12.3	SK 40	12	12,5	21	33	119	100
403.06.12.5	SK 40	12	12,5	21	40	169	150
403.06.16.0	SK 40	16	17	29	29	24	5
403.06.16	SK 40	16	17	29	29	44	25
403.06.16.1	SK 40	16	17	29	34	69	50
403.06.16.2	SK 40	16	17	29	34	94	75
403.06.16.3	SK 40	16	17	29	36	119	100
403.06.16.5	SK 40	16	17	29	43	169	150
503.06.08.1	SK 50	8	8,5	13	23	69	50
503.06.08.3	SK 50	8	8,5	13	25	119	100
503.06.08.5	SK 50	8	8,5	13	30	169	150
503.06.10.1	SK 50	10	10,5	18	23	69	50
503.06.10.3	SK 50	10	10,5	18	32	119	100
503.06.10.5	SK 50	10	10,5	18	37	169	150
503.06.12.1	SK 50	12	12,5	21	24	69	50
503.06.12.3	SK 50	12	12,5	21	33	119	100
503.06.12.5	SK 50	12	12,5	21	40	169	150
503.06.16.1	SK 50	16	17	29	34	69	50
503.06.16.3	SK 50	16	17	29	36	119	100
503.06.16.5	SK 50	16	17	29	43	169	150

*WERKZEUGAUFNAHMEN
JIS B 6339 (MAS 403 BT)*

*TOOLHOLDERS
JIS B 6339 (MAS 403 BT)*

*PORTE-OUTILS
JIS B 6339 (MAS 403 BT)*

JIS B 6339

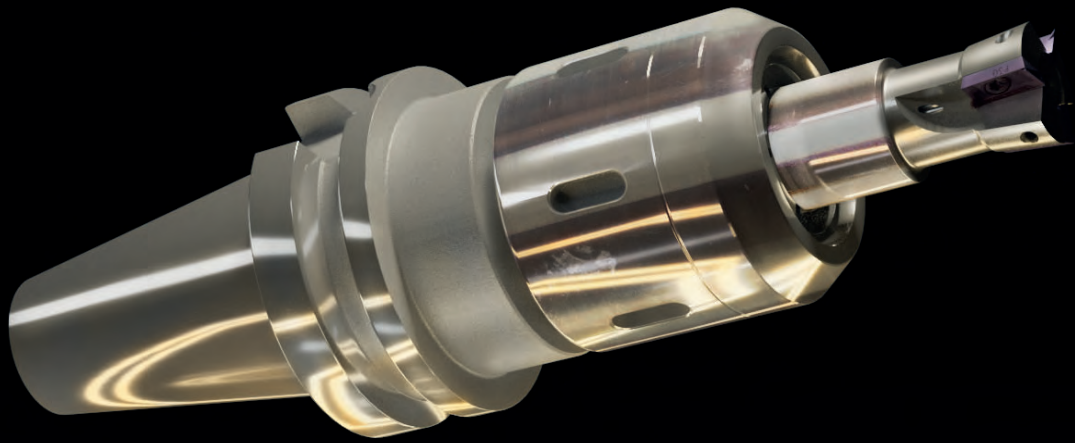

Vorgewuchtet
Pre-balanced
Pré-équilibré

G 6,3 15.000 min⁻¹

G 2,5 Feinwuchten gegen Aufpreis
G 2.5 Fine balancing at extra charge
G 2,5 Equilibrage fin contre un supplément

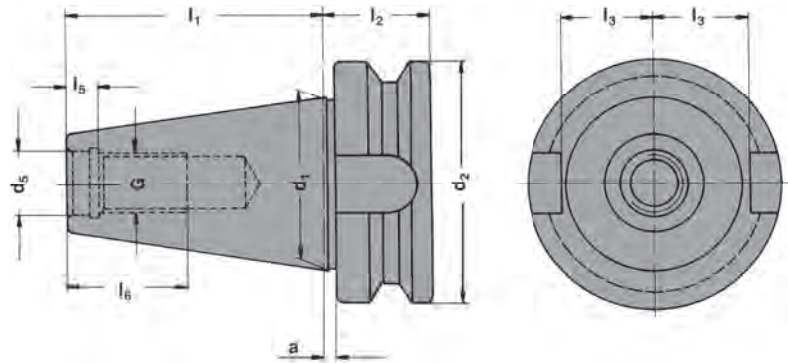

SK	d ₁	G	d ₅	d ₂	a	l ₁	l ₂	l ₃	l ₅	l ₆	e	d ₆
30	31,75	M12	12,5	46	2	48,4	22	16,3	7,0	24	-	-
40	44,45	M16	17,0	63	2	65,4	27	22,5	8,2	32	27	M4
50	69,85	M24	25,0	100	3	101,8	38	35,3	11,0	47	42	M6

Mit innerer Kühlmittelzufuhr über den Bund - Form AD/B

With internal coolant through the collar - form AD/B
Avec arrosage interne par la collerette - forme AD/B

Bei Lieferung mit Gewindestiften verschlossen
Delivery with headless screws in closed position
Livraison en état fermé avec de vis sans tête

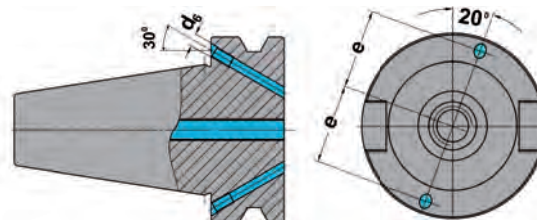

Werkstoff: Legierter Einsatzstahl mit einer Zugfestigkeit im Kern von min. 1200 N/mm². Einsatzgehärtet HRC 60 ± 2 (HV 700 ± 50), Härtetiefe 0,8 mm ± 0,2 mm, brüniert und präzisionsgeschliffen.

Form AD/B: Lieferung in Ausführung AD, Form B mit lösbaren Gewindestiften verschlossen.
Genauigkeit: Kegelwinkel - Toleranzqualität < AT 3 nach DIN 7187 und DIN 2080.

Material: *Alloyed case-hardened steel, tensile core strength of min. 1200 N/mm². Case hardened HRC 60 ± 2 (HV 700 ± 50), hardening depth 0.8 mm ± 0.2 mm, black-finished and precisely grinded.*

Form AD/B: *Delivery in form AD, type B closed with releasable headless screws.*
Accuracy: *Quality of taper < AT 3 according to DIN 7187 and DIN 2080.*

Matière: Acier de cémentation allié. Résistance à la traction dans le noyau de min 1200 N/mm². Cémentation à HRC 60 ± 2 (HV 700 ± 50), profondeur de cémentation 0,8 mm ± 0,2 mm, bruni et rectifié précisément.

Forme AD/B: Livraison en forme AD, forme B fermée avec des vis amovibles sans tête.
Précision: Qualité du cône < AT 3 selon DIN 7187 et DIN 2080.



Index
Sommaire



2.05	2.06	2.09	2.10
2.11	2.13	2.20	2.21
2.22	2.23	2.25	2.27
2.29	2.30	2.31	2.32
2.33	2.34	2.36	2.37
2.41	2.42	2.43	2.44



Collet chucks DIN 6391 for collets DIN 6388 (ISO 10897) OZ-system
Mandrins à pinces DIN 6391 pour pinces DIN 6388 (ISO 10897) système OZ



Verwendung:
Zur Aufnahme von Werkzeugen mit Zylinderschaft in Spannzangen.
Application:
For mounting straight-shank tools in collets.
Application:
Pour le serrage d'outils avec queue cylindrique dans des pinces de serrage.

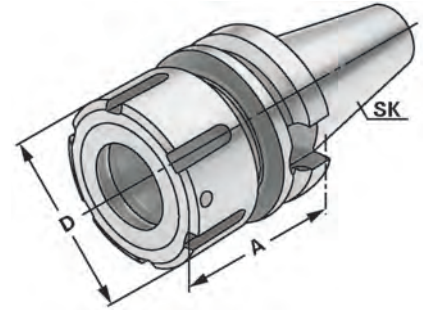

JIS B 6339	AD/B	$\nearrow \leq 0,003$	G6,3 15.000 min-1	14.04
------------	------	-----------------------	----------------------	-------

Bestell-Nr. Order no. Référence	SK	Spannbereich Capacity Capacité	A	D
305.01.16 *	BT 30	2 – 16 (OZ 16)	60	43
305.01.25 *	BT 30	2 – 25 (OZ 25)	80	60
406.01.16	BT 40	2 – 16 (OZ 16)	70	43
406.01.25	BT 40	2 – 25 (OZ 25)	70	60
406.01.32	BT 40	3 – 32 (OZ 32)	90	72
506.01.25	BT 50	2 – 25 (OZ 25)	85	60
506.01.32	BT 50	3 – 32 (OZ 32)	90	72

* JIS B 6339 Form AD
* JIS B 6339 form AD
* JIS B 6339 forme AD

Lieferumfang: Mit kugelgelagerter Spannmutter
Delivery: With ball bearing clamping nut
Livraison: Avec écrou de serrage à roulement à billes

Gewuchtete Ausführung



Balanced type
Type équilibré

Bestell-Nr. Order no. Référence	Abmessung Size Dimension
---------------------------------------	--------------------------------

Wuchten auf G 2,5 von vorgewuchteten Kemmler-Werkzeugen
Balancing at G 2.5 of pre-balanced Kemmler-tools
Équilibrage sur G 2,5 d'outils Kemmler pré-équilibrés

W25	Ohne Wuchtprotokoll Without balancing report Sans protocole d'équilibrage
W25.2	Mit Wuchtprotokoll With balancing report Avec protocole d'équilibrage

Wuchten von nicht vorgewuchteten Werkzeugen
Balancing of unbalanced tools
Équilibrage d'outils non-équilibrés

W25.1	Ohne Wuchtprotokoll Without balancing report Sans protocole d'équilibrage
-------	--



Collet chucks for collets DIN 6499 (ISO 15488) ER-system
Mandrins à pinces pour pinces DIN 6499 (ISO 15488) système ER



Verwendung:
Zur Aufnahme von Werkzeugen mit
Zylinderschaft in Spannzangen.

Application:
For mounting straight-shank tools in
collets.

Application:
Pour le serrage d'outils avec queue
cylindrique dans des pinces de serrage.

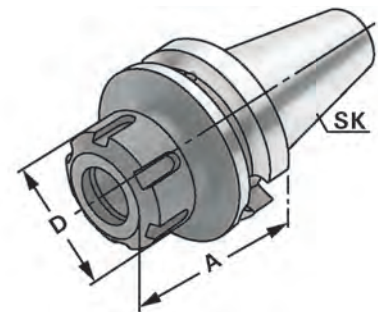

2

JIS B 6339



AD

 $\nearrow \leq 0,003$ G6.3
15.000 min-1

14.04

Bestell-Nr. Order no. Référence	SK	Spannbereich Capacity Capacité	A	D
305.02.10	BT 30	1 – 10 (ER 16)	70	32
305.02.13	BT 30	2 – 13 (ER 20)	70	35
305.02.16	BT 30	2 – 16 (ER 25)	70	42
305.02.20	BT 30	2 – 20 (ER 32)	70	50
305.02.26	BT 30	3 – 26 (ER 40)	70	63
305.02.10.1	BT 30	1 – 10 (ER 16)	100	32
305.02.13.1	BT 30	2 – 13 (ER 20)	100	35
305.02.16.1	BT 30	2 – 16 (ER 25)	100	42
305.02.20.1	BT 30	2 – 20 (ER 32)	100	50
405.02.10	BT 40	1 – 10 (ER 16)	63	32
405.02.13	BT 40	2 – 13 (ER 20)	70	35
405.02.16	BT 40	2 – 16 (ER 25)	60	42
405.02.20	BT 40	2 – 20 (ER 32)	70	50
405.02.26	BT 40	3 – 26 (ER 40)	80	63
405.02.10.1	BT 40	1 – 10 (ER 16)	100	32
405.02.13.1	BT 40	2 – 13 (ER 20)	100	35
405.02.16.1	BT 40	2 – 16 (ER 25)	100	42
405.02.20.1	BT 40	2 – 20 (ER 32)	100	50
405.02.26.1	BT 40	3 – 26 (ER 40)	100	63

Lieferumfang: Mit gewuchteter Spannmutter
Delivery: With balanced clamping nut
Livraison: Avec écrou de serrage équilibré





Collet chucks for collets DIN 6499 (ISO 15488) ER-system
Mandrins à pinces pour pinces DIN 6499 (ISO 15488) système ER

2



Verwendung:
Zur Aufnahme von Werkzeugen mit Zylinderschaft in Spannzangen.

Application:
For mounting straight-shank tools in collets.

Application:
Pour le serrage d'outils avec queue cylindrique dans des pinces de serrage.

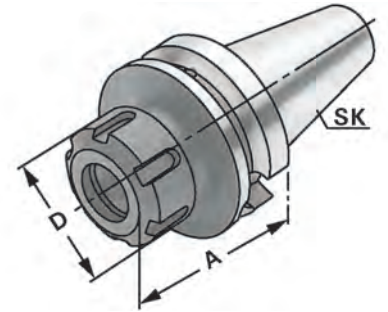

JIS B 6339



AD/B

 $\nearrow \leq 0,003$ G6,3
15.000 min⁻¹

14.04

Bestell-Nr. Order no. Référence	SK	Spannbereich Capacity Capacité	A	D
406.02.10	BT 40	1 – 10 (ER 16)	63	32
406.02.13	BT 40	2 – 13 (ER 20)	70	35
406.02.16	BT 40	2 – 16 (ER 25)	60	42
406.02.20	BT 40	2 – 20 (ER 32)	70	50
406.02.26	BT 40	3 – 26 (ER 40)	80	63
406.02.10.1	BT 40	1 – 10 (ER 16)	100	32
406.02.13.1	BT 40	2 – 13 (ER 20)	100	35
406.02.16.1	BT 40	2 – 16 (ER 25)	100	42
406.02.20.1	BT 40	2 – 20 (ER 32)	100	50
406.02.26.1	BT 40	3 – 26 (ER 40)	100	63
406.02.10.2	BT 40	1 – 10 (ER 16)	160	32
406.02.13.2	BT 40	2 – 13 (ER 20)	160	35
406.02.16.2	BT 40	2 – 16 (ER 25)	160	42
406.02.20.2	BT 40	2 – 20 (ER 32)	160	50
406.02.26.2	BT 40	3 – 26 (ER 40)	160	63
406.02.10.3	BT 40	1 – 10 (ER 16)	200	32
406.02.13.3	BT 40	2 – 13 (ER 20)	200	35
406.02.16.3	BT 40	2 – 16 (ER 25)	200	42
406.02.20.3	BT 40	2 – 20 (ER 32)	200	50
406.02.26.3	BT 40	3 – 26 (ER 40)	200	63

Lieferumfang: Mit gewichteter Spannmutter
Delivery: With balanced clamping nut
Livraison: Avec écrou de serrage équilibré



9.03



10.11



10.22



10.53



10.27

Collet chucks for collets DIN 6499 (ISO 15488) ER-system
Mandrins à pinces pour pinces DIN 6499 (ISO 15488) système ER



Verwendung:
Zur Aufnahme von Werkzeugen mit Zylinderschaft in Spannzangen.
Application:
For mounting straight-shank tools in collets.
Application:
Pour le serrage d'outils avec queue cylindrique dans des pinces de serrage.

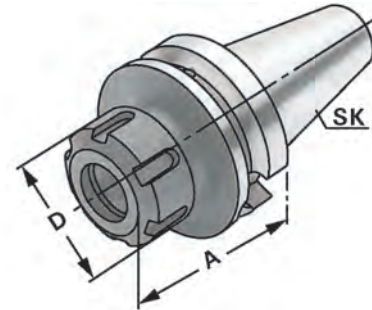

2

JIS B 6339

 $\nearrow \leq 0,003$ G6.3
15.000 min-1

Bestell-Nr. Order no. Référence	SK	Spannbereich Capacity Capacité	A	D
506.02.13	BT 50	2 – 13 (ER 20)	70	35
506.02.16	BT 50	2 – 16 (ER 25)	70	42
506.02.20	BT 50	2 – 20 (ER 32)	70	50
506.02.26	BT 50	3 – 26 (ER 40)	80	63
506.02.10.1	BT 50	1 – 10 (ER 16)	100	32
506.02.13.1	BT 50	2 – 13 (ER 20)	100	35
506.02.16.1	BT 50	2 – 16 (ER 25)	100	42
506.02.20.1	BT 50	2 – 20 (ER 32)	100	50
506.02.26.1	BT 50	3 – 26 (ER 40)	100	63
506.02.10.2	BT 50	1 – 10 (ER 16)	160	32
506.02.13.2	BT 50	2 – 13 (ER 20)	160	35
506.02.16.2	BT 50	2 – 16 (ER 25)	160	42
506.02.20.2	BT 50	2 – 20 (ER 32)	160	50
506.02.26.2	BT 50	3 – 26 (ER 40)	160	63
506.02.10.3	BT 50	1 – 10 (ER 16)	200	32
506.02.13.3	BT 50	2 – 13 (ER 20)	200	35
506.02.16.3	BT 50	2 – 16 (ER 25)	200	42
506.02.20.3	BT 50	2 – 20 (ER 32)	200	50
506.02.26.3	BT 50	3 – 26 (ER 40)	200	63

Lieferumfang: Mit gewuchteter Spannmutter
Delivery: With balanced clamping nut
Livraison: Avec écrou de serrage équilibré



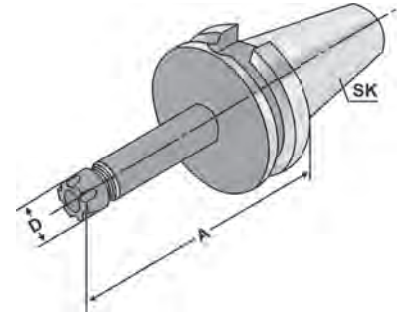

2

**Verwendung:**
Zur Aufnahme von Werkzeugen mit Zylinderschaft in Spannzangen.**Application:**
For mounting straight-shank tools in collets.**Application:**
Pour le serrage d'outils avec queue cylindrique dans des pinces de serrage.

JIS B 6339



AD/B

 $\uparrow \leq 0,003$ G6,3
15.000 min-1

14.04

Bestell-Nr. Order no. Référence	SK	Spannbereich Capacity Capacité	A	D
305.02.07*	BT 30	1 – 7 (ER 11)	70	16
305.02.07.1*	BT 30	1 – 7 (ER 11)	100	16
305.02.07.10*	BT 30	1 – 10 (ER 16)	70	22
305.02.07.10.1*	BT 30	1 – 10 (ER 16)	100	22
406.02.07	BT 40	1 – 7 (ER 11)	55	16
406.02.07.1	BT 40	1 – 7 (ER 11)	100	16
406.02.07.2	BT 40	1 – 7 (ER 11)	160	16
406.02.07.10	BT 40	1 – 10 (ER 16)	55	22
406.02.07.10.1	BT 40	1 – 10 (ER 16)	100	22
406.02.07.10.2	BT 40	1 – 10 (ER 16)	160	22

* JIS B 6339 Form AD

* JIS B 6339 form AD

* JIS B 6339 forme AD

Lieferumfang: Mit gewuchteter Spannmutter
Delivery: With balanced clamping nut
Livraison: Avec écrou de serrage équilibré

Gewuchtete Ausführung**Balanced type
Type équilibré**

Bestell-Nr. Order no. Référence	Abmessung Size Dimension
Wuchten auf G 2,5 von vorgewuchteten Kemmler-Werkzeugen Balancing at G 2.5 of pre-balanced Kemmler-tools Équilibrage sur G 2,5 de outils Kemmler pré-équilibrés	
W25	Ohne Wuchtprotokoll Without balancing report Sans protocole d'équilibrage
W25.2	Mit Wuchtprotokoll With balancing report Avec protocole d'équilibrage
Wuchten von nicht vorgewuchteten Werkzeugen Balancing of unbalanced tools Équilibrage d'outils non-équilibrés	
W25.1	Ohne Wuchtprotokoll Without balancing report Sans protocole d'équilibrage



9.03

10.10

10.23

10.27

Collet chucks for collets KPS-system

(MAS 403 BT)

Mandrins à pinces pour pinces système KPS

**Verwendung:**

Zur Aufnahme von Werkzeugen mit Zylinderschaft in Spannzangen.
Für Anwendungen im HSC-Bereich und für hochpräzise Bearbeitungsergebnisse.

Application:

For mounting straight-shank tools in collets.
To use for high speed cutting and high precision milling.

Application:

Pour le serrage d'outils avec queue cylindrique dans des pinces de serrage.
Pour l'usage dans le coupage à grande vitesse et dans l'usinage à grande précision.

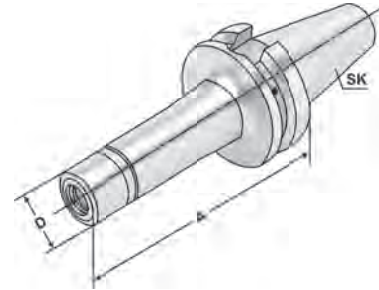

2

JIS B 6339



AD

 $\nearrow \leq 0,003$ G2.5
30.000 min-1

14.04

Bestell-Nr. Order no. Référence	SK	Spannbereich Capacity Capacité	A	D
305.03.10	BT 30	1 – 10 (KPS 10)	60	27,5
305.03.16	BT 30	4 – 16 (KPS 16)	60	40
305.03.10.1	BT 30	1 – 10 (KPS 10)	90	27,5
305.03.16.1	BT 30	4 – 16 (KPS 16)	90	40
405.03.10	BT 40	1 – 10 (KPS 10)	60	27,5
405.03.16	BT 40	4 – 16 (KPS 16)	60	40
405.03.10.1	BT 40	1 – 10 (KPS 10)	90	27,5
405.03.16.1	BT 40	4 – 16 (KPS 16)	90	40
405.03.10.2	BT 40	1 – 10 (KPS 10)	120	27,5
405.03.16.2	BT 40	4 – 16 (KPS 16)	120	40
405.03.10.3	BT 40	1 – 10 (KPS 10)	160	27,5
405.03.16.3	BT 40	4 – 16 (KPS 16)	160	40
505.03.10	BT 50	1 – 10 (KPS 10)	105	27,5
505.03.16	BT 50	4 – 16 (KPS 16)	105	40
505.03.10.1	BT 50	1 – 10 (KPS 10)	135	27,5
505.03.16.1	BT 50	4 – 16 (KPS 16)	135	40
505.03.10.2	BT 50	1 – 10 (KPS 10)	165	27,5
505.03.16.2	BT 50	4 – 16 (KPS 16)	165	40

Lieferumfang: Mit gewuchteter Spannmutter
Delivery: With balanced clamping nut
Livraison: Avec écrou de serrage équilibré





2



Verwendung:
Zur Aufnahme von Werkzeugen mit Zylinderschaft nach DIN 1835 Form A+B+E und DIN 6535 Form HB+HE

Application:
For mounting straight-shank tools acc. DIN 1835 form A+B+E and DIN 6535 form HB+HE

Application:
Pour le serrage d'outils avec queue cylindrique suivant DIN 1835 forme A+B+E et DIN 6535 forme HB+HE

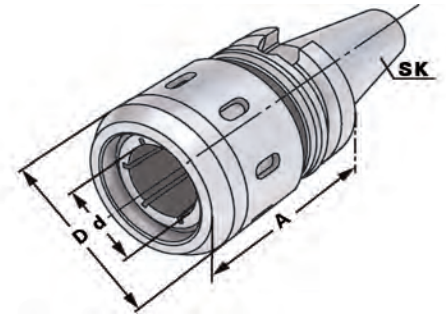

JIS B 6339



AD/B

$\nabla \leq 0,003$

G6,3
15.000 min-1



14.04

Bestell-Nr. Order no. Référence	SK	Spannbereich Capacity Capacité	A	D	d
406.64.20	BT 40	20 (HKS 20)	90	53	20
406.64.25	BT 40	25 (HKS 25)	90	63	25
406.64.32	BT 40	32 (HKS 32)	90	68	32
506.64.20	BT 50	20 (HKS 20)	95	53	20
506.64.25	BT 50	25 (HKS 25)	95	63	25
506.64.32	BT 50	32 (HKS 32)	90	68	32



RELEASE THE BEAST



KEMMLER

K KEMMLER®
Präzisionswerkzeuge

2

Verwendung:

Zum Spannen von zylindrischen Werkzeugschäften mit seitlicher Spannfläche nach DIN 1835 Form B (Weldon).

Application:

For mounting straight-shank tools with lateral flat according to DIN 1835 form B (Weldon).

Application:

Pour le serrage d'outils avec queue cylindrique et avec méplat suivant DIN 1835 forme B (Weldon).

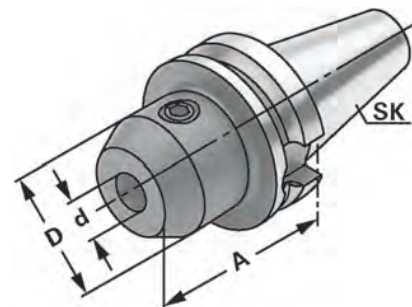

JIS B 6339



AD

 $\nabla \leq 0,003$
 $G6,3$
 15.000 min⁻¹

14.04

Bestell-Nr. Order no. Référence	SK	d ^{H4}	A	D
305.04.06	BT 30	6	50	25
305.04.08	BT 30	8	50	28
305.04.10	BT 30	10	50	35
305.04.12	BT 30	12	50	42
305.04.14	BT 30	14	50	44
305.04.16	BT 30	16	63	48
305.04.18	BT 30	18	63	50
305.04.20	BT 30	20	63	52
405.04.06	BT 40	6	50	25
405.04.08	BT 40	8	50	28
405.04.10	BT 40	10	63	35
405.04.12	BT 40	12	63	42
405.04.14	BT 40	14	63	44
405.04.16	BT 40	16	63	48
405.04.18	BT 40	18	63	50
405.04.20	BT 40	20	63	52
405.04.25	BT 40	25	90	65
405.04.32	BT 40	32	100	72
405.04.06.1	BT 40	6	100	25
405.04.08.1	BT 40	8	100	28
405.04.10.1	BT 40	10	100	35
405.04.12.1	BT 40	12	100	42
405.04.14.1	BT 40	14	100	44
405.04.16.1	BT 40	16	100	48
405.04.18.1	BT 40	18	100	50
405.04.20.1	BT 40	20	100	52

Hinweis: Ab d = 25 mit zwei Spannschrauben
Note: From d = 25 on two clamping screws
Observation: A partir de d = 25 avec deux vis de serrage

Lieferumfang: Mit Spannschraube
Delivery: With clamping screw
Livraison: Avec vis de serrage



End mill holders DIN 6359 for end mills DIN 1835-B

(MAS 403 BT)

Porte-fraises DIN 6359 pour queues cylindriques DIN 1835-B

**Verwendung:**

Zum Spannen von zylindrischen Werkzeugschäften mit seitlicher Spannfläche nach DIN 1835 Form B (Weldon).

Application:

For mounting straight-shank tools with lateral flat according to DIN 1835 form B (Weldon).

Application:

Pour le serrage d'outils avec queue cylindrique et avec méplat suivant DIN 1835 forme B (Weldon).

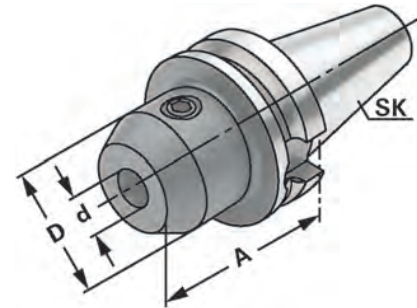

2

JIS B 6339

 $\nearrow \leq 0,003$ G6,3
15.000 min⁻¹

Bestell-Nr. Order no. Référence	SK	d ^{H4}	A	D
406.04.16.0	BT 40	16	35	45
406.04.20.0	BT 40	20	35	45
406.04.25.0	BT 40	25	35	55
406.04.32.0	BT 40	32	65	50
406.04.06	BT 40	6	50	25
406.04.08	BT 40	8	50	28
406.04.10	BT 40	10	63	35
406.04.12	BT 40	12	63	42
406.04.14	BT 40	14	63	44
406.04.16	BT 40	16	63	48
406.04.18	BT 40	18	63	50
406.04.20	BT 40	20	63	52
406.04.25	BT 40	25	90	65
406.04.32	BT 40	32	100	72
406.04.40	BT 40	40	120	80
406.04.06.1	BT 40	6	100	25
406.04.08.1	BT 40	8	100	28
406.04.10.1	BT 40	10	100	35
406.04.12.1	BT 40	12	100	42
406.04.14.1	BT 40	14	100	44
406.04.16.1	BT 40	16	100	48
406.04.18.1	BT 40	18	100	50
406.04.20.1	BT 40	20	100	52
406.04.06.2	BT 40	6	160	25
406.04.08.2	BT 40	8	160	28
406.04.10.2	BT 40	10	160	35
406.04.12.2	BT 40	12	160	42
406.04.14.2	BT 40	14	160	44
406.04.16.2	BT 40	16	160	48
406.04.18.2	BT 40	18	160	50
406.04.20.2	BT 40	20	160	52
406.04.25.2	BT 40	25	160	65
406.04.32.2	BT 40	32	160	72
406.04.40.2	BT 40	40	160	80

2



Verwendung:
 Zum Spannen von zylindrischen Werkzeugschäften mit seitlicher Spannfläche nach DIN 1835 Form B (Weldon).

Application:
 For mounting straight-shank tools with lateral flat according to DIN 1835 form B (Weldon).

Application:
 Pour le serrage d'outils avec queue cylindrique et avec méplat suivant DIN 1835 forme B (Weldon).

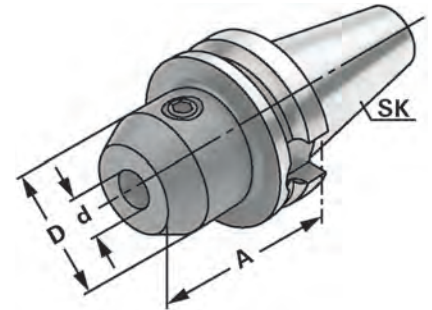

JIS B 6339 AD/B $\sqrt{\text{Ra}} \leq 0,003$ G6,3 15.000 min⁻¹ 13.04

Bestell-Nr. Order no. Référence	SK	d ^{H4}	A	D
506.04.06	BT 50	6	63	25
506.04.08	BT 50	8	63	28
506.04.10	BT 50	10	63	35
506.04.12	BT 50	12	80	42
506.04.14	BT 50	14	80	44
506.04.16	BT 50	16	80	48
506.04.18	BT 50	18	80	50
506.04.20	BT 50	20	80	52
506.04.25	BT 50	25	100	65
506.04.32	BT 50	32	105	72
506.04.40	BT 50	40	110	80
506.04.06.1	BT 50	6	100	25
506.04.08.1	BT 50	8	100	28
506.04.10.1	BT 50	10	100	35
506.04.12.1	BT 50	12	100	42
506.04.14.1	BT 50	14	100	44
506.04.16.1	BT 50	16	100	48
506.04.18.1	BT 50	18	100	50
506.04.20.1	BT 50	20	100	52
506.04.06.2	BT 50	6	160	25
506.04.08.2	BT 50	8	160	28
506.04.10.2	BT 50	10	160	35
506.04.12.2	BT 50	12	160	42
506.04.14.2	BT 50	14	160	44
506.04.16.2	BT 50	16	160	48
506.04.18.2	BT 50	18	160	50
506.04.20.2	BT 50	20	160	52
506.04.25.2	BT 50	25	160	65
506.04.32.2	BT 50	32	160	72
506.04.40.2	BT 50	40	160	80

Hinweis: Ab d = 25 mit zwei Spannschrauben
Note: From d = 25 on two clamping screws
Observation: A partir de d = 25 avec deux vis de serrage

Lieferumfang: Mit Spannschraube
Delivery: With clamping screw
Livraison: Avec vis de serrage



End mill holders DIN 6359 for end mills DIN 1835-B

(MAS 403 BT)

Porte-fraises DIN 6359 pour queues cylindriques DIN 1835-B

**Verwendung:**

Zum Spannen von zylindrischen Werkzeugschäften mit seitlicher Spannfläche nach DIN 1835 Form B (Weldon).

Application:

For mounting straight-shank tools with lateral flat according to DIN 1835 form B (Weldon).

Application:

Pour le serrage d'outils avec queue cylindrique et avec méplat suivant DIN 1835 forme B (Weldon).

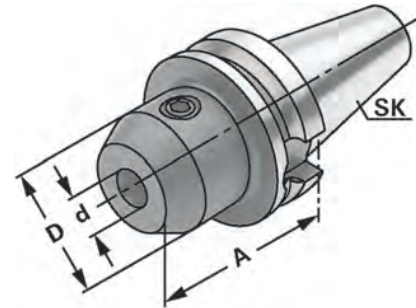

2

JIS B 6339



AD/B

 $\uparrow \leq 0,003$
 $G6,3$
15.000 min⁻¹

Bestell-Nr.
Order no.
Référence

SK

d^{H4}

A

D

506.04.06.3

BT 50

6

200

25

506.04.08.3

BT 50

8

200

28

506.04.10.3

BT 50

10

200

35

506.04.12.3

BT 50

12

200

42

506.04.14.3

BT 50

14

200

44

506.04.16.3

BT 50

16

200

48

506.04.18.3

BT 50

18

200

50

506.04.20.3

BT 50

20

200

52

506.04.25.3

BT 50

25

200

65

506.04.32.3

BT 50

32

200

72

506.04.40.3

BT 50

40

200

80

Hinweis:

Ab d = 25 mit zwei Spannschrauben

Note:

From d = 25 on two clamping screws

Observation:

A partir de d = 25 avec deux vis de serrage

Lieferumfang:

Mit Spannschraube

Delivery:

With clamping screw

Livraison:

Avec vis de serrage



10.52

10.27



End mill holders DIN 6359 with coolant channels for end mills DIN 1835-B

Porte-fraises DIN 6359 avec canaux d'arrosage pour queues cylindriques DIN 1835-B

2

**Verwendung:**

Zum Spannen von zylindrischen Werkzeugschäften mit seitlicher Spannfläche nach DIN 1835 Form B (Weldon). Mit Kühlkanälen für optimale Kühlung der Werkzeugschneide.

Application:

For mounting straight-shank tools with lateral flat according to DIN 1835 form B (Weldon). With coolant channels for optimal coolant at the cutting edge.

Application:

Pour le serrage d'outils avec queue cylindrique et avec méplat suivant DIN 1835 forme B (Weldon). Avec canaux d'arrosage pour un refroidissement optimal aux lames.

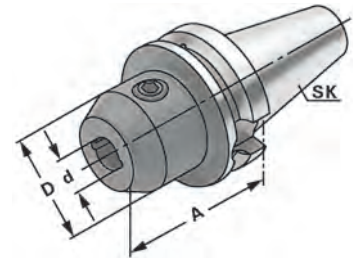

JIS B 6339



AD/B

 $\nearrow \leq 0,003$ G6,3
15.000 min⁻¹

13.04

Bestell-Nr. Order no. Référence	SK	d ^{H4}	A	D
406.04.06.K	BT 40	6	50	25
406.04.08.K	BT 40	8	50	28
406.04.10.K	BT 40	10	63	35
406.04.12.K	BT 40	12	63	42
406.04.14.K	BT 40	14	63	44
406.04.16.K	BT 40	16	63	48
406.04.18.K	BT 40	18	63	50
406.04.20.K	BT 40	20	63	52
406.04.25.K	BT 40	25	90	65
406.04.32.K	BT 40	32	100	72
406.04.40.K	BT 40	40	120	80
406.04.06.1.K	BT 40	6	100	25
406.04.08.1.K	BT 40	8	100	28
406.04.10.1.K	BT 40	10	100	35
406.04.12.1.K	BT 40	12	100	42
406.04.14.1.K	BT 40	14	100	44
406.04.16.1.K	BT 40	16	100	48
406.04.18.1.K	BT 40	18	100	50
406.04.20.1.K	BT 40	20	100	52

Hinweis:

Ab d = 25 mit zwei Spannschrauben
d = 6 bis 18 mit zwei Kühlkanälen
d = 20 bis 40 mit vier Kühlkanälen

Für Werkzeuge mit innerer Kühlmittelzufuhr muss ein O-Ring eingesetzt werden.

Note:

From d = 25 on two clamping screws

d = 6 to 18 with two coolant channels

d = 20 to 40 with four coolant channels

For tools with through coolant an O-ring must be used.

Observation:

A partir de d = 25 avec deux vis de serrage

d = 6 bis 18 avec deux canaux d'arrosage

d = 20 bis 40 avec quatre canaux d'arrosage

Pour outils avec arrosage interne il faut utiliser un joint torique.

Lieferumfang:

Mit Spannschraube und O-Ring

Delivery:

With clamping screw and O-ring

Livraison:

Avec vis de serrage et joint torique



End mill holders DIN 6359 with coolant channels for end mills DIN 1835-B

Porte-fraises DIN 6359 avec canaux d'arrosage pour queues cylindriques DIN 1835-B

**Verwendung:**

Zum Spannen von zylindrischen Werkzeugschäften mit seitlicher Spannfläche nach DIN 1835 Form B (Weldon). Mit Kühlkanälen für optimale Kühlung der Werkzeugschneide.

Application:

For mounting straight-shank tools with lateral flat according to DIN 1835 form B (Weldon). With coolant channels for optimal coolant at the cutting edge.

Application:

Pour le serrage d'outils avec queue cylindrique et avec méplat suivant DIN 1835 forme B (Weldon). Avec canaux d'arrosage pour un refroidissement optimal aux lames.

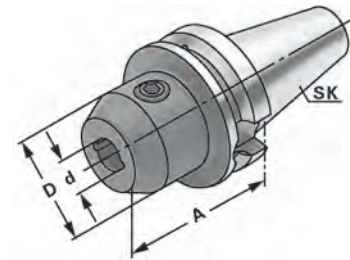

2

JIS B 6339

 $\nearrow \leq 0,003$ G6,3
15.000 min⁻¹

Bestell-Nr. Order no. Référence	SK	d ^{H4}	A	D
506.04.06.K	BT 50	6	63	25
506.04.08.K	BT 50	8	63	28
506.04.10.K	BT 50	10	63	35
506.04.12.K	BT 50	12	80	42
506.04.14.K	BT 50	14	80	44
506.04.16.K	BT 50	16	80	48
506.04.18.K	BT 50	18	80	50
506.04.20.K	BT 50	20	80	52
506.04.25.K	BT 50	25	100	65
506.04.32.K	BT 50	32	105	72
506.04.40.K	BT 50	40	110	80

Hinweis:

Ab d = 25 mit zwei Spannschrauben
d = 6 bis 18 mit zwei Kühlkanälen
d = 20 bis 40 mit vier Kühlkanälen

Für Werkzeuge mit innerer Kühlmittelzufuhr muss ein O-Ring eingesetzt werden.

Note:

From d = 25 on two clamping screws
d = 6 to 18 with two coolant channels
d = 20 to 40 with four coolant channels

For tools with through coolant an O-ring must be used.

Observation:

A partir de d = 25 avec deux vis de serrage
d = 6 bis 18 avec deux canaux d'arrosage
d = 20 bis 40 avec quatre canaux d'arrosage

Pour outils avec arrosage interne il faut utiliser un joint torique.

**Lieferumfang:**

Mit Spannschraube und O-Ring

Delivery:

With clamping screw and O-ring

Livraison:

Avec vis de serrage et joint torique



2



Verwendung:
 Zum Spannen von zylindrischen Werkzeugschäften mit geneigter Spannfläche nach DIN 1835 Form E (Whistle Notch).

Application:
 For mounting straight-shank tools and inclined flat according to DIN 1835 form E (Whistle Notch).

Application:
 Pour le serrage d'outils avec queue cylindrique et avec méplat incliné suivant DIN 1835 forme E (Whistle Notch).

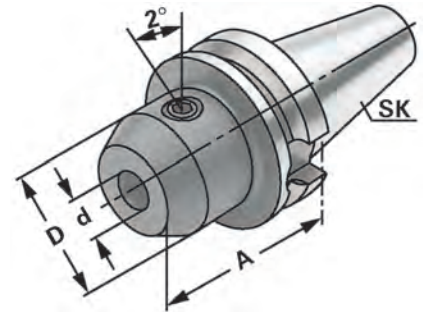

JIS B 6339 AD/B $\sqrt{\text{Ra}} \leq 0,003$ G6,3 15.000 min⁻¹ 14.04

Bestell-Nr. Order no. Référence	SK	d ^{H4}	A	D
406.05.06	BT 40	6	50	25
406.05.08	BT 40	8	50	28
406.05.10	BT 40	10	63	35
406.05.12	BT 40	12	63	42
406.05.14	BT 40	14	63	44
406.05.16	BT 40	16	63	48
406.05.18	BT 40	18	63	50
406.05.20	BT 40	20	63	52
406.05.25	BT 40	25	90	65
406.05.32	BT 40	32	100	72
406.05.40	BT 40	40	120	80
506.05.06	BT 50	6	63	25
506.05.08	BT 50	8	63	28
506.05.10	BT 50	10	63	35
506.05.12	BT 50	12	80	42
506.05.14	BT 50	14	80	44
506.05.16	BT 50	16	80	48
506.05.18	BT 50	18	80	50
506.05.20	BT 50	20	80	52
506.05.25	BT 50	25	100	65
506.05.32	BT 50	32	105	72
506.05.40	BT 50	40	110	80

Hinweis: Ab d = 25 mit zwei Spannschrauben
Note: From d = 25 on two clamping screws
Observation: A partir de d = 25 avec deux vis de serrage

Lieferumfang: Mit Spannschraube und axialer Verstellechraube
Delivery: With clamping screw and axial adjustment bolt
Livraison: Avec vis de serrage et vis de butée axiale



Adaptor sleeves for MT with tang DIN 6383

(MAS 403 BT)

Douilles de réduction pour CM à tenon DIN 6383



Verwendung:
Zur Aufnahme von Werkzeugen mit Morsekegelschaft und Austreibblappen nach DIN 228-1 Form B.

Application:
For mounting tools with Morse taper shank and tang according to DIN 228-1 form B.

Application:
Pour le serrage d'outils avec queue cône Morse et tenon suivant DIN 228-1 forme B.

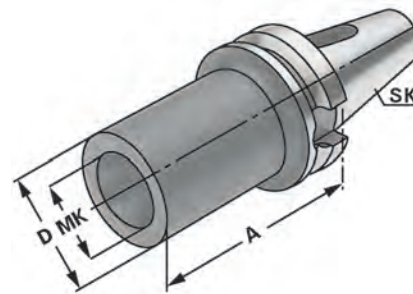

2

JIS B 6339



$\nearrow \leq 0,005$

G6,3
15.000 min-1

Bestell-Nr. Order no. Référence	SK	MK MT CM	A	D
305.07.01 *	BT 30	1	45	25
305.07.02 *	BT 30	2	60	32
305.07.03 *	BT 30	3	75	40
405.07.01 *	BT 40	1	50	25
405.07.02 *	BT 40	2	50	32
405.07.03 *	BT 40	3	70	40
405.07.04 *	BT 40	4	95	48
406.07.01	BT 40	1	50	25
406.07.02	BT 40	2	50	32
406.07.03	BT 40	3	70	40
406.07.04	BT 40	4	95	48
506.07.01	BT 50	1	45	25
506.07.02	BT 50	2	60	32
506.07.03	BT 50	3	65	40
506.07.04	BT 50	4	95	48
506.07.05	BT 50	5	105	63

* JIS B 6339 Form AD

* JIS B 6339 form AD

* JIS B 6339 forme AD



8.12



10.27



Verwendung:
Zum Spannen von Werkzeugen mit Morsekegelschaft und Anzugsgewinde nach DIN 228-1 Form A.

Application:
For clamping tools with Morse taper shank and thread according to DIN 228-1 form A.

Application:
Pour le serrage d'outils avec queue cône Morse et filetage suivant DIN 228-1 forme A.

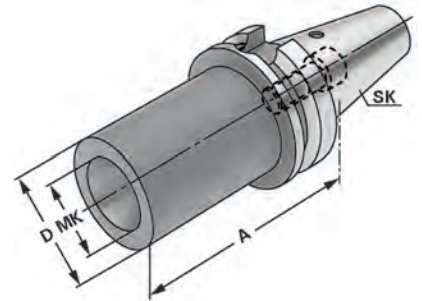

JIS B 6339	Form A	$\nabla \leq 0,005$	G6.3 15.000 min ⁻¹
------------	--------	---------------------	----------------------------------

Bestell-Nr. Order no. Référence	SK	MK MT CM	M	A	D
405.08.01	BT 40	1	M6	50	25
405.08.02	BT 40	2	M10	50	32
405.08.03	BT 40	3	M12	70	40
405.08.04	BT 40	4	M16	95	48
405.08.04A*	BT 40	4	M16	110	63
505.08.01	BT 50	1	M6	45	25
505.08.02	BT 50	2	M10	60	32
505.08.03	BT 50	3	M12	65	40
505.08.04	BT 50	4	M16	70	48
505.08.04A*	BT 50	4	M16	85	63
505.08.05	BT 50	5	M20	100	63
505.08.05A*	BT 50	5	M20	118	78

- * Mit Mitnahmeausfräsung nach DIN 2201
- * With drive flats according to DIN 2201
- * Avec des fraises d'entraînement suivant DIN 2201

Lieferumfang: Mit eingebauter Fräseranzugsschraube
Delivery: With built-in tightening bolt
Livraison: Avec vis de serrage montée





Adaptor sleeves for ISO-toolholders
Douilles de réduction pour porte-outils ISO/SA



Verwendung:
Zur Aufnahme von Steilkegeln nach DIN 69871, JIS B 6339 und DIN 2080.
Application:
For holding tapers according to DIN 69871, JIS B 6339 and DIN 2080.
Application:
Pour le serrage de porte-outils suivant DIN 69871, JIS B 6339 et DIN 2080.

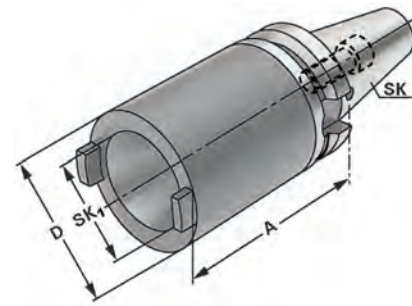

JIS B 6339 Form A $\nabla \leq 0,005$ G6,3 15.000 min⁻¹

Bestell-Nr. Order no. Référence	SK	SK ₁	A	D
405.09.30	BT 40	SK 30	60	63
405.09.40	BT 40	SK 40	100	63
505.09.40	BT 50	SK 40	70	70
505.09.50	BT 50	SK 50	120	97

Hinweis: Lieferung erfolgt mit eingebauter Schraube für Werkzeuge mit gekürztem Steilkegel. Schraube für DIN 2080 Werkzeuge beiliegend.
Note: Delivered with a built-in screw for shortened taper tools. Additional screw for DIN 2080 tools included.
Observation: Livraison avec un vis incorporée pour outils à cône court. Vis pour cônes DIN 2080 incluse.



2



Verwendung:
Zur Aufnahme von Walzen-, Walzenstirnfräsern oder Messerköpfen mit Längs- oder Quernut.

Application:
For mounting milling cutters with transverse or longitudinal groove.

Application:
Pour le serrage de fraises à rainure transversale ou à rainure longitudinale.

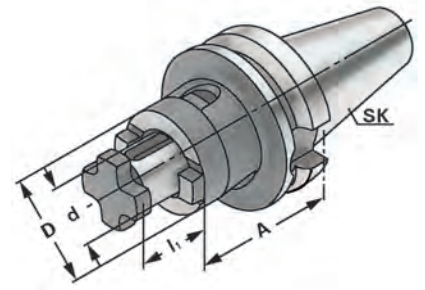

JIS B 6339



AD/B

$\nabla \leq 0,005$

G6,3
15.000 min⁻¹

Bestell-Nr. Order no. Référence	SK	d _{H6}	A	l ₁	D
305.10.16 *	BT 30	16	45	17	32
305.10.22 *	BT 30	22	47	19	40
305.10.27 *	BT 30	27	49	21	48
406.10.16	BT 40	16	55	17	32
406.10.22	BT 40	22	55	19	40
406.10.27	BT 40	27	55	21	48
406.10.32	BT 40	32	60	24	58
406.10.40	BT 40	40	60	27	70
406.10.16.1	BT 40	16	100	17	32
406.10.22.1	BT 40	22	100	19	40
406.10.27.1	BT 40	27	100	21	48
406.10.32.1	BT 40	32	100	24	58
406.10.40.1	BT 40	40	100	27	70
406.10.16.2	BT 40	16	160	17	32
406.10.22.2	BT 40	22	160	19	40
406.10.27.2	BT 40	27	160	21	48
406.10.32.2	BT 40	32	160	24	58
406.10.40.2	BT 40	40	160	27	70

* JIS B 6339 Form AD

* JIS B 6339 form AD

* JIS B 6339 forme AD

Lieferumfang: Mit Fräseranzugsschraube, Mitnehmerring und Passfeder
Delivery: With tightening bolt, driving ring and feather key
Livraison: Avec vis de blocage, bague d'entraînement et clavette

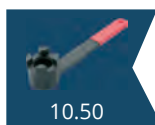



Combi shell mill holders DIN 6358
 Porte-fraises à double usage DIN 6358

(MAS 403 BT)



Verwendung:
 Zur Aufnahme von Walzen-, Walzenstirnfräsern oder Messerköpfen mit Längs- oder Quernut.

Application:
 For mounting milling cutters with transverse or longitudinal groove.

Application:
 Pour le serrage de fraises à rainure transversale ou à rainure longitudinale.

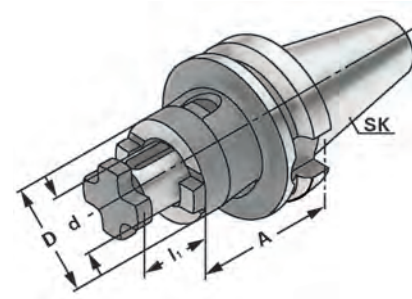

JIS B 6339 AD/B $\sqrt{\text{Ra}} \leq 0,005$ G6,3 15.000 min⁻¹

Bestell-Nr. Order no. Référence	SK	d_{H6}	A	l_1	D
506.10.16	BT 50	16	70	17	32
506.10.22	BT 50	22	70	19	40
506.10.27	BT 50	27	70	21	48
506.10.32	BT 50	32	70	24	58
506.10.40	BT 50	40	70	27	70
506.10.16.2	BT 50	16	160	17	32
506.10.22.2	BT 50	22	160	19	40
506.10.27.2	BT 50	27	160	21	48
506.10.32.2	BT 50	32	160	24	58
506.10.40.2	BT 50	40	160	27	70

Lieferumfang: Mit Fräseranzugsschraube, Mitnehmerring und Passfeder
Delivery: With tightening bolt, driving ring and feather key
Livraison: Avec vis de blocage, bague d'entraînement et clavette





Shell mill holders DIN 6357 with enlarged contact face and coolant exit bores on the end face

Porte-fraises à trou lisse DIN 6357 avec face de contact élargie et conduits pour l'arrosage frontal

Verwendung:

Zur Aufnahme von Messerköpfen und Fräsern mit Quernut.

Application:

For mounting milling cutters with transversal groove.

Application:

Pour le serrage de fraises à rainure transversale.

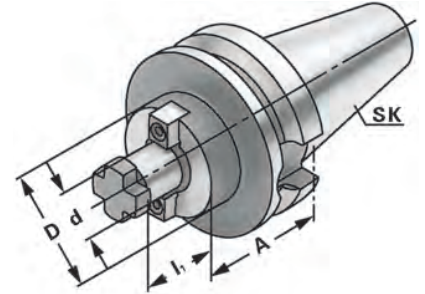

2

JIS B 6339



AD/B

$\gamma \leq 0,005$

G6,3
15.000 min-1

Bestell-Nr. Order no. Référence	SK	d_{h6}	A	l_1	D
305.11.16 *	BT 30	16	40	17	38
305.11.22 *	BT 30	22	40	19	48
305.11.27 *	BT 30	27	40	21	58
305.11.32 *	BT 30	32	50	24	78
405.11.16 *	BT 40	16	40	17	38
405.11.22 *	BT 40	22	40	19	48
405.11.27 *	BT 40	27	40	21	58
405.11.32 *	BT 40	32	50	24	78
405.11.40 *	BT 40	40	50	27	88
406.11.16	BT 40	16	40	17	38
406.11.22	BT 40	22	40	19	48
406.11.27	BT 40	27	40	21	58
406.11.32	BT 40	32	50	24	78
406.11.40	BT 40	40	50	27	88
406.11.16.1	BT 40	16	100	17	38
406.11.22.1	BT 40	22	100	19	48
406.11.27.1	BT 40	27	100	21	58
406.11.32.1	BT 40	32	100	24	78
406.11.40.1	BT 40	40	100	27	88
406.11.16.2	BT 40	16	160	17	38
406.11.22.2	BT 40	22	160	19	48
406.11.27.2	BT 40	27	160	21	58
406.11.32.2	BT 40	32	160	24	78
406.11.40.2	BT 40	40	160	27	88

* JIS B 6339 Form AD

* JIS B 6339 form AD

* JIS B 6339 forme AD

BT 30 ohne Kühlkanalbohrungen an der Stirnseite

BT 30 without coolant exit bores on the end face

BT 30 sans alésages pour l'arrosage frontal

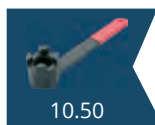

10.50



10.48



10.49

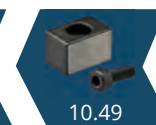

10.49



10.27

Shell mill holders DIN 6357 with enlarged contact face and coolant exit bores on the end face
 Porte-fraises à trou lisse DIN 6357 avec face de contact élargie et conduits pour l'arrosage frontal



Verwendung:
 Zur Aufnahme von Messerköpfen und Fräsern mit Quernut.

Application:
 For mounting milling cutters with transversal groove.

Application:
 Pour le serrage de fraises à rainure transversale.

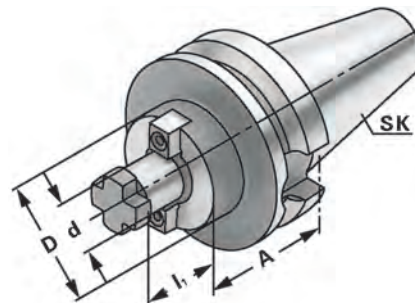

JIS B 6339



$\nabla \leq 0,005$

G6,3
 15.000 min-1

Bestell-Nr. Order no. Référence	SK	d_{H6}	A	l_1	D
506.11.22	BT 50	22	40	19	48
506.11.27	BT 50	27	40	21	58
506.11.32	BT 50	32	50	24	78
506.11.40	BT 50	40	50	27	88
506.11.60	BT 50	60	80	40	129
506.11.22.1	BT 50	22	100	19	48
506.11.27.1	BT 50	27	100	21	58
506.11.32.1	BT 50	32	100	24	78
506.11.40.1	BT 50	40	100	27	88
506.11.22.2	BT 50	22	160	19	48
506.11.27.2	BT 50	27	160	21	58
506.11.32.2	BT 50	32	160	24	78
506.11.40.2	BT 50	40	160	27	88

d = 40/d = 60: Für große Planfräser mit vier zusätzlichen Gewindebohrungen nach DIN 2079.
 For large diameter face mill cutters with four additional threaded holes according to DIN 2079.
 Pour fraises à surfacer à grands diamètres avec quatre trous taraudés additionnels suivant DIN 2079.

Lieferumfang: Mit Mitnehmersteinen, Kreuzschraube und Zylinderkopfschraube nach DIN 912 für Fräser mit innerer Kühlmittelzufuhr.
 Bei d = 60 nur mit vier Befestigungsschrauben nach DIN 912.

Delivery: With drivers, cross head retaining screw and cylinder head retaining screw for cutters with central coolant.
 For d = 60 only with four fixation screws according to DIN 912.

Livraison: Avec tenons, une vis cruciforme et une vis à tête cylindrique suivant DIN 912 pour fraises avec arrosage central.
 Pour d = 60 seulement avec quatre vis de fixation suivant DIN 912.





2



Verwendung:
Zur Aufnahme von Werkzeugen mit Zylinderschaft.

Application:
For mounting tools with straight shanks.

Application:
Pour le serrage d'outils avec queue cylindrique.

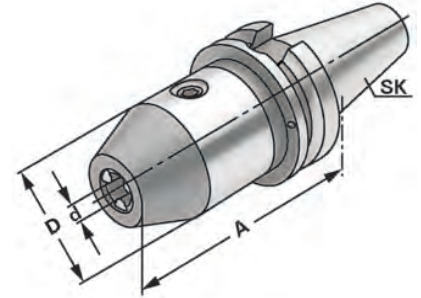

JIS B 6339 AD $\nearrow \leq 0,030$ G6,3 15.000 min-1 14.04

Bestell-Nr. Order no. Référence	SK	Spannbereich Capacity Capacité	d	A	D
305.15.08	BT 30	0 - 8		73	36
305.15.13	BT 30	1,0 - 13		93	50
305.15.16	BT 30	2,5 - 16		98	50
405.15.08	BT 40	0 - 8		78	36
405.15.13	BT 40	1,0 - 13		98	50
405.15.16	BT 40	2,5 - 16		103	50
505.15.13	BT 50	1,0 - 13		111	50
505.15.16	BT 50	2,5 - 16		113	50

Hinweis: Hohe Präzision und Rundlaufgenauigkeit von $\leq 0,03$ mm. Sichere Spannung des Werkzeuges durch mechanische Spannkraftverstärkung. Kein selbständiges Lösen der Spannung während der Bearbeitung bei Links- oder Rechtslauf, sowie bei Spindelstop. Spannen und Lösen mit Sechskantschlüssel.

Note: High precision and accurate concentricity of ≤ 0.03 mm. Secure gripping of the tool through mechanical amplification of the clamping force. No automatic slackening of the clamping force while machining with either clockwise or counter clockwise rotation or on spindle stop. Clamping and releasing effected by means of an Allen wrench.

Observation: Précision élevée et exactitude de circularité de $\leq 0,03$ mm. Serrage sûr de l'outil grâce à l'amplification de la force de serrage. Pas de desserrage intempestif en cours d'usinage lors de la rotation la gauche ou la droite, de même qu'en cas d'arrêt de la broche. Serrage et desserrage en utilisant un clé sur à fourche.

Lieferumfang: Mit Spannschlüssel
Delivery: With wrench
Livraison: Avec clé de serrage





CNC-Drill chucks for clockwise and counter clockwise rotation
Mandrins de perçage CNC pour rotation gauche-droite

(MAS 403 BT)



Verwendung:
Zur Aufnahme von Werkzeugen mit Zylinderschaft.
Application:
For mounting tools with straight shanks.
Application:
Pour le serrage d'outils avec queue cylindrique.

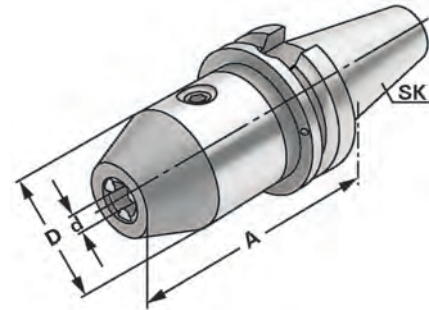

JIS B 6339 AD/B $\leq 0,030$ G6,3 15.000 min⁻¹ 14.04

Bestell-Nr. Order no. Référence	SK	Spannbereich Capacity Capacité	A	D
406.15.08	BT 40	0 - 8	78	36
406.15.13	BT 40	1,0 - 13	98	50
406.15.16	BT 40	2,5 - 16	103	50
506.15.13	BT 50	1,0 - 13	111	50
506.15.16	BT 50	2,5 - 16	113	50

Hinweis: Hohe Präzision und Rundlaufgenauigkeit von $\leq 0,03$ mm. Sichere Spannung des Werkzeuges durch mechanische Spannkraftverstärkung. Kein selbständiges Lösen der Spannung während der Bearbeitung bei Links- oder Rechtslauf, sowie bei Spindelstop. Spannen und Lösen mit Sechskantschlüssel.

Note: High precision and accurate concentricity of ≤ 0.03 mm. Secure gripping of the tool through mechanical amplification of the clamping force. No automatic slackening of the clamping force while machining with either clockwise or counter clockwise rotation or on spindle stop. Clamping and releasing effected by means of an Allen wrench.

Observation: Précision élevée et exactitude de circularité de $\leq 0,03$ mm. Serrage sûr de l'outil grâce à l'amplification de la force de serrage. Pas de desserrage intempestif en cours d'usinage lors de la rotation la gauche ou la droite, de même qu'en cas d'arrêt de la broche. Serrage et desserrage en utilisant un clé sur à fourche.

Lieferumfang: Mit Spannschlüssel
Delivery: With wrench
Livraison: Avec clé de serrage

Gewuchtete Ausführung



Balanced type
Type équilibré

Bestell-Nr. Order no. Référence	Abmessung Size Dimension
---------------------------------------	--------------------------------

Wuchten auf G 2,5 von vorgewuchteten Kemmler-Werkzeugen
Balancing at G 2.5 of pre-balanced Kemmler-tools
Équilibrage sur G 2,5 d'outils Kemmler pré-équilibrés

W25 **Ohne Wuchtprotokoll**
Without balancing report
Sans protocole d'équilibrage

W25.2 **Mit Wuchtprotokoll**
With balancing report
Avec protocole d'équilibrage

Wuchten von nicht vorgewuchteten Werkzeugen
Balancing of unbalanced tools
Équilibrage d'outils non-équilibrés

W25.1 **Ohne Wuchtprotokoll**
Without balancing report
Sans protocole d'équilibrage





Quick change tapping chucks with length compensation on compression and expansion

Mandrins de taraudage à changement rapide avec compensation longitudinale à la compression et traction



Verwendung:
Zur Aufnahme von Schnellwechsel-Ein-sätzen für Gewindebohrer.

Application:
For the chucking of quick change adaptors for taps.

Application:
Pour le serrage d'adaptateurs porte-tarands à changement rapide.

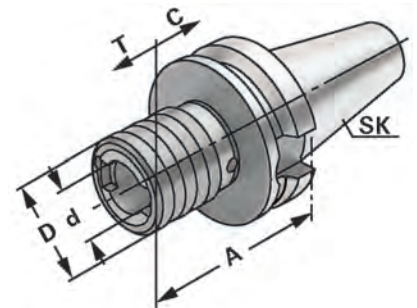

JIS B 6339 Form A



Bestell-Nr. Order no. Référence	SK	Spannbereich Capacity Capacité	Größe Size Taille	A	D	d	C	T
305.16.12	BT 30	M3 - M14	1	64	38	19	7	7
305.16.20	BT 30	M5 - M22	2	95	54	31	12	12
405.16.12	BT 40	M3 - M14	1	65	38	19	7	7
405.16.20	BT 40	M5 - M22	2	93	54	31	12	12
405.16.36	BT 40	M14 - M36	3	166	78	48	20	20
505.16.12	BT 50	M3 - M14	1	100	38	19	7	7
505.16.20	BT 50	M5 - M22	2	105	54	31	12	12
505.16.36	BT 50	M14 - M36	3	142	78	48	17,5	17,5

Hinweis: Für Bearbeitungszentren ohne Synchronspindel.
Note: For machining centres without synchronous spindle.
Observation: Pour centres d'usinage sans broche synchrone.





ohne Längenausgleich auf Druck und Zug

(MAS 403 BT)

Quick change tapping chucks **without** length compensation on compression and expansion
 Mandrins de taraudage à changement rapide **sans** compensation longitudinale à la compression et traction



Verwendung:
 Zur Aufnahme von Schnellwechsel-Einsätzen für Gewindebohrer.
Application:
 For the chucking of quick change adaptors for taps.
Application:
 Pour le serrage d'adapteurs portetarauds à changement rapide.

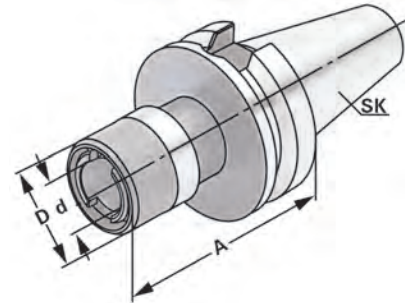

JIS B 6339 AD

14.04

Bestell-Nr. Order no. Référence	SK	Spannbereich Capacity Capacité	Größe Size Taille	A	D	d
305.16.12.1	BT 30	M3 - M14	1	66	38	19
305.16.20.1	BT 30	M5 - M22	2	80	54	31
405.16.12.1	BT 40	M3 - M14	1	72	38	19
405.16.20.1	BT 40	M5 - M22	2	93	54	31
405.16.36.1	BT 40	M14 - M36	3	130	78	48
505.16.12.1	BT 50	M3 - M14	1	80	38	19
505.16.20.1	BT 50	M5 - M22	2	95	54	31
505.16.36.1	BT 50	M14 - M36	3	142	78	48

Hinweis: Für Bearbeitungszentren mit Synchronspindel.
Note: For machining centres with synchronous spindle.
Observation: Pour centres d'usinage avec broche synchrone.





Tapping chucks for synchronisation for collets DIN 6499 (ISO 15488) ER-system

Mandrins de taraudage pour synchronisation pour pinces DIN 6499 (ISO 15488) système ER

2

**Verwendung:**

Für Bearbeitungszentren mit Synchronspindel.

Application:

For machining centres with synchronous spindle.

Application:

Pour centres d'usinage avec broche synchrone.

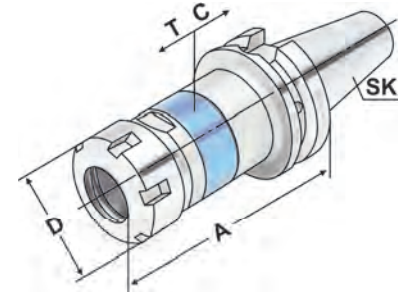

JIS B 6339

AD/B

 $\lambda \leq 0,060$ G6,3
15.000 min-1

Bestell-Nr. Order no. Référence	SK	Spannbereich Capacity Capacité	A	D	T	C
406.16.02.10 *	BT 40	M3 – M12 (ER 16) SW25	81	28	0,5	0,5
406.16.02.13	BT 40	M3 – M16 (ER 20)	85	34	0,5	0,5
406.16.02.16	BT 40	M3 – M20 (ER 25)	89	42	0,5	0,5
406.16.02.20	BT 40	M3 – M27 (ER 32)	110	50	0,5	0,5
406.16.02.26	BT 40	M3 – M33 (ER 40)	115	63	0,5	0,5
506.16.02.10 *	BT 50	M3 – M12 (ER 16) SW25	95	28	0,5	0,5
506.16.02.13	BT 50	M3 – M16 (ER 20)	100	34	0,5	0,5
506.16.02.16	BT 50	M3 – M20 (ER 25)	110	42	0,5	0,5
506.16.02.20	BT 50	M3 – M27 (ER 32)	120	50	0,5	0,5
506.16.02.26	BT 50	M3 – M33 (ER 40)	120	63	0,5	0,5

*** Sechskantmutter**

* Hexagonal clamping nut

* Écrous hexagonal

Hinweis:

- Synchro-Gewindeschneidfutter kompensieren Synchronisationsfehler.
- Minimallängenausgleich in Druck- und Zugrichtung zwischen Synchronspindel und Gewindebohrer reduziert zu hohe Gewindeflankenreibungskräfte.
- Reduziert eventuelle Axialkrafteerhöhung während des Schneidzyklus auf ein Minimum.
- Geeignet für Innenkühlung.
- Kühlmitteldruck max. 100 bar.

Note:

- *Synchro tapping chucks compensate synchronisation errors.*
- *Minimal length compensation on compression and expansion balances very small pitch differences between synchro spindle and tap, which can cause high frictional forces on the thread flanks.*
- *A possible increase of axial force during the tapping process is reduced to a minimum.*
- *Suitable for internal coolant.*
- *Coolant pressure up to max. 100 bar.*

Observation:

- Mandrins de taraudage version „synchro“ compensent les erreurs éventuelles de synchronisation.
- Compensation longitudinale minimale à la compression et traction entre la broche synchronisée et le taraud réduit la friction au niveau des flancs de filets.
- Réduit au minimum les efforts éventuelles axiaux lors du cycle de taraudage.
- Approprié pour la lubrification centrale.
- Pression de lubrification max. 100 bar.

Lieferumfang:

Mit gewuchteter Spannmutter

Delivery:

With balanced clamping nut

Livraison:

Avec écrou de serrage équilibré



9.03



10.11



10.22



10.39



10.27

Drill chuck adaptors DIN 238

Arbres pour mandrins de perçage DIN 238

(MAS 403 BT)



Verwendung:
Zur Aufnahme von Bohrfuttern.

Application:
For mounting drill chucks.

Application:
Pour le serrage de mandrins de perçage.

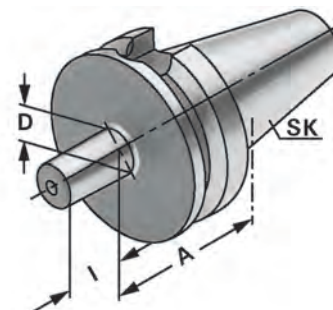

JIS B 6339

Form A

 $\nabla \leq 0,005$ G6,3
15.000 min⁻¹

Bestell-Nr. Order no. Référence	SK	D	A	I
305.14.12	BT 30	B12	25	18,5
305.14.16	BT 30	B16	25	24
405.14.12	BT 40	B12	25	18,5
405.14.16	BT 40	B16	25	24
405.14.18	BT 40	B18	32	32
505.14.16	BT 50	B16	32	24
505.14.18	BT 50	B18	32	32





Verwendung:
Zur Herstellung von Sonderwerkzeugen.

Application:
For the manufacturing of special tools.

Application:
Pour la fabrication d'outils spéciaux.

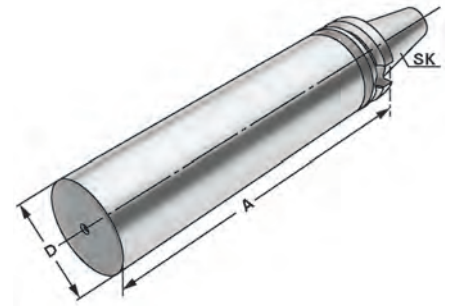

JIS B 6339 Form A

Bestell-Nr. Order no. Référence	SK	D	A
305.17.40	BT 30	40,5	160
405.17.63	BT 40	63	250
505.17.97	BT 50	97	315

Ausführung: Steilkegel und Bund gehärtet und geschliffen. Schaft weich zur weiteren Bearbeitung.
Version: *Cone and flange hardened and grinded. Soft body for later processing.*
Version: Cône et collerette durcis et rectifiés. Corps doux pour un usinage ultérieur.





Verwendung:
Zur Aufnahme von Werkzeugen mit Zylinderschaft nach DIN 1835 Form A+B+E und DIN 6535 Form HB+HE (größer Ø 20 mm nur mit Reduzierung).

Application:
For mounting straight-shank tools acc. DIN 1835 form A+B+E and DIN 6535 form HB+HE (larger than Ø 20 mm only with reduction sleeve).

Application:
Pour le serrage d'outils avec queue cylindrique suivant DIN 1835 forme A+B+E et DIN 6535 forme HB+HE (à partir de Ø 20 mm seulement avec réduction).

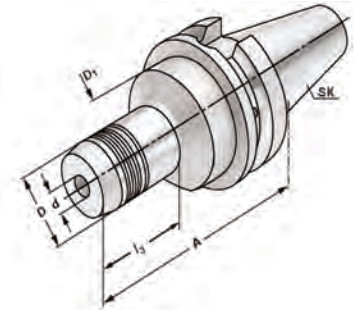

JIS B 6339 AD $\sqrt{\leq 0,003}$ G6,3 15.000 min⁻¹

14.04

Bestell-Nr. Order no. Référence	SK	d	A	D	D ₁	l ₁	l ₂	l ₃
305.H06	BT 30	6	60	26	45	37	10	33
305.H08	BT 30	8	64	28	45	37	10	29
305.H10	BT 30	10	64	30	45	42	10	37
305.H12	BT 30	12	72	32	45	47	10	43
305.H14	BT 30	14	70	34	45	47	10	45
305.H16	BT 30	16	90	38	45	52	10	47
305.H18	BT 30	18	90	40	45	52	10	68
305.H20	BT 30	20	90	42	45	52	10	68
405.H06	BT 40	6	90	26	50	37	10	43
405.H08	BT 40	8	90	28	50	37	10	43,5
405.H10	BT 40	10	90	30	50	42	10	44
405.H12	BT 40	12	90	32	50	47	10	44,5
405.H14	BT 40	14	90	34	50	47	10	47,5
405.H16	BT 40	16	90	38	50	52	10	47,5
405.H18	BT 40	18	90	40	50	52	10	47,5
405.H20	BT 40	20	90	42	50	52	10	47,5
405.H25	BT 40	25	90	50	63	58	10	51
405.H32	BT 40	32	110	60	60	62	10	81,5
405.H06.1	BT 40	6	150	26	50	102	10	102
405.H08.1	BT 40	8	150	28	50	103	10	103
405.H10.1	BT 40	10	150	30	50	104	10	104
405.H12.1	BT 40	12	150	32	50	105	10	105
405.H14.1	BT 40	14	150	34	50	105	10	105
405.H16.1	BT 40	16	150	38	50	106	10	106
405.H18.1	BT 40	18	150	40	50	107	10	107
405.H20.1	BT 40	20	150	42	50	108	10	108
405.H25.1	BT 40	25	150	50	50	123	10	123
405.H32.1	BT 40	32	150	60	50	123	10	123

Lieferumfang: Mit Spannschlüssel
Delivery: With wrench
Livraison: Avec clé de serrage

l₁ = max. Einstecktiefe l₂ = max. Verstellweg
l₁ = max. clamping depth l₂ = max. length adjustment range
l₁ = max. profondeur d'insertion l₂ = max. course de réglage





2



Verwendung:
Zur Aufnahme von Werkzeugen mit Zylinderschaft nach DIN 1835 Form A+B+E und DIN 6535 Form HB+HE (größer Ø 20 mm nur mit Reduzierung).

Application:
For mounting straight-shank tools acc. DIN 1835 form A+B+E and DIN 6535 form HB+HE (larger than Ø 20 mm only with reduction sleeve).

Application:
Pour le serrage d'outils avec queue cylindrique suivant DIN 1835 forme A+B+E et DIN 6535 forme HB+HE (à partir de Ø 20 mm seulement avec réduction).

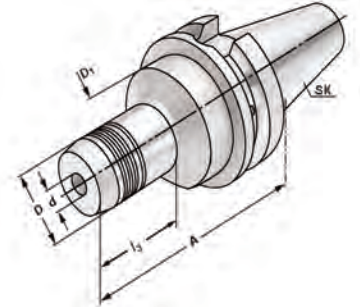

JIS B 6339



AD

$\nabla \leq 0,003$

G6,3
15.000 min-1



14.04

Bestell-Nr. Order no. Référence	SK	d	A	D	D ₁	l ₁	l ₂	l ₃
405.H06.2	BT 40	6	200	26	50	152	10	152
405.H08.2	BT 40	8	200	28	50	153	10	153
405.H10.2	BT 40	10	200	30	50	154	10	154
405.H12.2	BT 40	12	200	32	50	155	10	155
405.H14.2	BT 40	14	200	34	50	155	10	155
405.H16.2	BT 40	16	200	38	50	156	10	156
405.H18.2	BT 40	18	200	40	50	157	10	157
405.H20.2	BT 40	20	200	42	50	158	10	158
405.H25.2	BT 40	25	200	50	50	173	10	173
405.H32.2	BT 40	32	200	60	50	173	10	173
505.H06	BT 50	6	110	26	80	37	10	43
505.H08	BT 50	8	110	28	80	37	10	43,5
505.H10	BT 50	10	110	30	80	42	10	44
505.H12	BT 50	12	110	32	80	47	10	42
505.H14	BT 50	14	110	34	80	47	10	42
505.H16	BT 50	16	110	38	80	52	10	45
505.H18	BT 50	18	110	40	80	52	10	45
505.H20	BT 50	20	110	42	80	52	10	47,5
505.H25	BT 50	25	110	50	80	58	10	47,5
505.H32	BT 50	32	110	60	80	62	10	47,5

Lieferumfang: Mit Spannschlüssel
Delivery: With wrench
Livraison: Avec clé de serrage

l₁ = max. Einstecktiefe l₂ = max. Verstellweg
l₁ = max. clamping depth l₂ = max. length adjustment range
l₁ = max. profondeur d'insertion l₂ = max. course de réglage

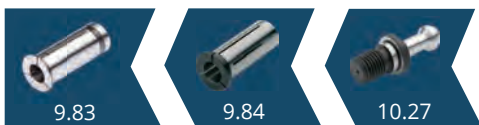

Shrink chucks 3° for mounting of solid carbide and HSS-tool shanks - slim

Mandrins de frettage 3° pour le serrage de queues d'outils carbures de type HM et HSS - élancé



Verwendung:
Zur Aufnahme von Werkzeugen mit Zylinderschaft.

Application:
For mounting straight-shank tools.

Application:
Pour le serrage d'outils avec queue cylindrique.

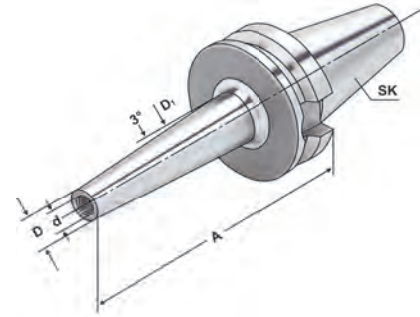

JIS B 6339

 $\nearrow \leq 0,003$
 $G2,5$
25.000 min⁻¹

Bestell-Nr. Order no. Référence	SK	d	A	D	D ₁	l ₁	l ₂
406.72.03	BT 40	3	90	9	15,5	6	-
406.72.04	BT 40	4	90	10	16,5	8	-
406.72.05	BT 40	5	90	11	17,5	10	-
406.72.06	BT 40	6	90	12	18,5	36	10
406.72.08	BT 40	8	90	14	20,5	36	10
406.72.10	BT 40	10	90	16	22,5	42	10
406.72.12	BT 40	12	90	18	24,5	47	10
406.72.03.1	BT 40	3	120	9	19,5	6	-
406.72.04.1	BT 40	4	120	10	20,5	8	-
406.72.05.1	BT 40	5	120	11	21,5	10	-
406.72.06.1	BT 40	6	120	12	22,5	36	10
406.72.08.1	BT 40	8	120	14	24,5	36	10
406.72.10.1	BT 40	10	120	16	26,5	42	10
406.72.12.1	BT 40	12	120	18	28,5	47	10
406.72.06.2	BT 40	6	160	12	26,5	36	10
406.72.08.2	BT 40	8	160	14	28,5	36	10
406.72.10.2	BT 40	10	160	16	30,5	42	10
406.72.12.2	BT 40	12	160	18	32,5	47	10

Hinweis: Aufnahme für Induktiv-, Kontakt- und Heißluftschumpfgeräte geeignet.
Schafttoleranz bei Ø 6 - Ø 12 mm = h₆

Note: *Toolholders suitable for induction-, contact- and hot air shrink units.*
Ø 6 - Ø 12 with h₆-tolerance

Observation: Porte-outils convenables pour machines à frotter par induction,
par contact, ou par air chaud.
Ø 6 - Ø 12 avec h₆-tolerance

l₁ = max. Einstecktiefe l₂ = max. Verstellweg
l₁ = max. clamping depth l₂ = max. length adjustment range
l₁ = max. profondeur d'insertion l₂ = max. course de réglage

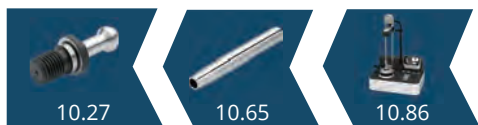



Shrink chucks 4,5° for mounting of solid carbide and HSS-tool shanks

Mandrins de frettage 4,5° pour le serrage de queues d'outils carbures de type HM et HSS

2

**Verwendung:**

Zur Aufnahme von Werkzeugen mit Zylinderschaft.

Application:

For mounting straight-shank tools.

Application:

Pour le serrage d'outils avec queue cylindrique.

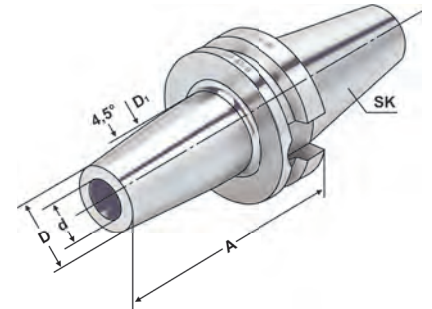

JIS B 6339



AD/B

 $\nabla \leq 0,003$ G2,5
25.000 min⁻¹

Bestell-Nr. Order no. Référence	SK	d	A	D	D ₁	l ₁	l ₂
305.70.03 *	BT 30	3	80	11	15	10	-
305.70.04 *	BT 30	4	80	14	22	20	5
305.70.05 *	BT 30	5	80	16	22	20	5
305.70.06 *	BT 30	6	80	21	27	36	10
305.70.08 *	BT 30	8	80	21	27	36	10
305.70.10 *	BT 30	10	90	24	32	42	10
305.70.12 *	BT 30	12	90	24	32	47	10
305.70.14 *	BT 30	14	90	27	34	47	10
305.70.16 *	BT 30	16	90	27	34	50	10
305.70.18 *	BT 30	18	90	33	42	50	10
305.70.20 *	BT 30	20	90	33	42	52	10
305.70.25 *	BT 30	25	100	44	53	58	10
406.70.03	BT 40	3	80	11	15	10	-
406.70.04	BT 40	4	80	14	22	20	5
406.70.05	BT 40	5	80	16	22	20	5
406.70.06	BT 40	6	90	21	27	36	10
406.70.08	BT 40	8	90	21	27	36	10
406.70.10	BT 40	10	90	24	32	41	10
406.70.12	BT 40	12	90	24	32	47	10
406.70.14	BT 40	14	90	27	34	47	10
406.70.16	BT 40	16	90	27	34	50	10
406.70.18	BT 40	18	90	33	42	50	10
406.70.20	BT 40	20	90	33	42	52	10
406.70.25	BT 40	25	100	44	53	58	10
406.70.32	BT 40	32	100	44	53	58	10

* JIS B 6339 Form AD

* JIS B 6339 form AD

* JIS B 6339 forme AD

Für Ø 3, 4 und 5 mm nur Hartmetallschäfte verwenden!*For Ø 3, 4 and 5 mm only solid carbide tool shanks must be used!*

Pour Ø 3, 4 et 5 mm il faut seulement utiliser de queues d'outils carbures de type HM!

Hinweis: Aufnahme für Induktiv-, Kontakt- und Heißluftschumpfergeräte geeignet. Schafttoleranz bei Ø 3, 4 und 5 mm = h₄, bei Ø 6 – Ø 32 mm = h₆**Note:** Toolholders suitable for induction-, contact- and hot air shrink units. Ø 3, 4, 5 with h₄-tolerance and Ø 6 – Ø 32 with h₆-tolerance**Observation:** Porte-outils convenables pour machines à fretter par induction, par contact, ou par air chaud. Ø 3, 4, 5 avec h₄-tolerance et Ø 6 – Ø 32 avec h₆-tolerancel₁ = max. Einstecktiefel₁ = max. clamping depthl₁ = max. profondeur d'insertionl₂ = max. Verstellwegl₂ = max. length adjustment rangel₂ = max. course de réglage

10.27



10.65

Shrink chucks 4,5° for mounting of solid carbide and HSS-tool shanks

Mandrins de frettage 4,5° pour le serrage de queues d'outils carbures de type HM et HSS



Verwendung:
Zur Aufnahme von Werkzeugen mit Zylinderschaft.

Application:
For mounting straight-shank tools.

Application:
Pour le serrage d'outils avec queue cylindrique.

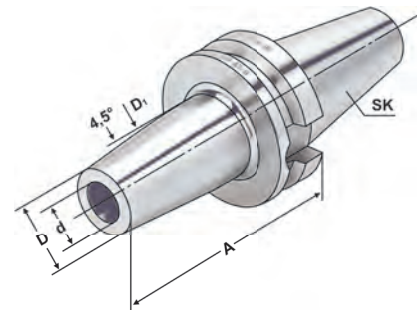

2

JIS B 6339

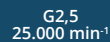

AD/B

 $\leq 0,003$

 $G2,5$
25.000 min⁻¹

Bestell-Nr. Order no. Référence	SK	d	A	D	D ₁	l ₁	l ₂
406.70.06.1	BT 40	6	120	21	27	36	10
406.70.08.1	BT 40	8	120	21	27	36	10
406.70.10.1	BT 40	10	120	24	32	41	10
406.70.12.1	BT 40	12	120	24	32	47	10
406.70.14.1	BT 40	14	120	27	34	47	10
406.70.16.1	BT 40	16	120	27	34	50	10
406.70.18.1	BT 40	18	120	33	42	50	10
406.70.20.1	BT 40	20	120	33	42	52	10
406.70.25.1	BT 40	25	120	44	53	58	10
406.70.06.2	BT 40	6	160	21	27	36	10
406.70.08.2	BT 40	8	160	21	27	36	10
406.70.10.2	BT 40	10	160	24	32	42	10
406.70.12.2	BT 40	12	160	24	32	47	10
406.70.14.2	BT 40	14	160	27	34	47	10
406.70.16.2	BT 40	16	160	27	34	50	10
406.70.18.2	BT 40	18	160	33	42	50	10
406.70.20.2	BT 40	20	160	33	42	52	10
406.70.25.2	BT 40	25	160	44	53	58	10
406.70.32.2	BT 40	32	160	44	62	58	10

Hinweis: Aufnahme für Induktiv-, Kontakt- und Heißluftschumpfgeräte geeignet.
Schafttoleranz bei Ø 6 - Ø 32 mm = h₆

Note: *Toolholders suitable for induction-, contact- and hot air shrink units.
Ø 6 - Ø 32 with h₆-tolerance*

Observation: Porte-outils convenables pour machines à fretter par induction,
par contact, ou par air chaud.
Ø 6 - Ø 32 avec h₆-tolerance

l₁ = max. Einstecktiefe
l₁ = max. clamping depth

l₁ = max. profondeur d'insertion

l₂ = max. Verstellweg

l₂ = max. length adjustment range

l₂ = max. course de réglage

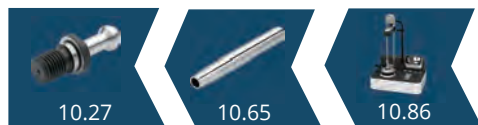



Shrink chucks 4,5° for mounting of solid carbide and HSS-tool shanks

Mandrins de frettage 4,5° pour le serrage de queues d'outils carbures de type HM et HSS

2

**Verwendung:**

Zur Aufnahme von Werkzeugen mit Zylinderschaft.

Application:

For mounting straight-shank tools.

Application:

Pour le serrage d'outils avec queue cylindrique.

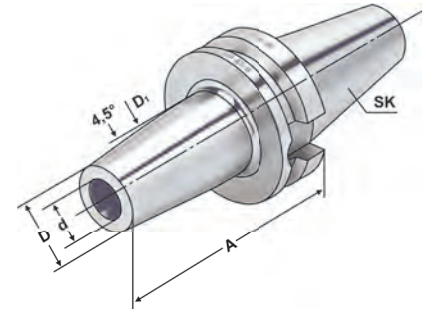

JIS B 6339



AD/B

 $\nabla \leq 0,003$ G2.5
25.000 min⁻¹

Bestell-Nr. Order no. Référence	SK	d	A	D	D ₁	l ₁	l ₂
506.71.04	BT 50	4	100	14	22	20	5
506.71.05	BT 50	5	100	16	22	20	5
506.71.06	BT 50	6	100	21	27	36	10
506.71.08	BT 50	8	100	21	27	36	10
506.71.10	BT 50	10	100	24	32	41	10
506.71.12	BT 50	12	100	24	32	47	10
506.71.14	BT 50	14	100	27	34	47	10
506.71.16	BT 50	16	100	27	34	50	10
506.71.18	BT 50	18	110	33	42	50	10
506.71.20	BT 50	20	110	33	42	52	10
506.71.25	BT 50	25	120	44	53	58	10
506.71.32	BT 50	32	120	44	53	62	10
506.71.06.1	BT 50	6	120	21	27	36	10
506.71.08.1	BT 50	8	120	21	27	36	10
506.71.10.1	BT 50	10	120	24	32	41	10
506.71.12.1	BT 50	12	120	24	32	47	10
506.71.14.1	BT 50	14	120	27	34	47	10
506.71.16.1	BT 50	16	120	27	34	50	10
506.71.18.1	BT 50	18	120	33	42	50	10
506.71.20.1	BT 50	20	120	33	42	52	10

Hinweis: Aufnahme für Induktiv-, Kontakt- und Heißluftschumpfergeräte geeignet.
Schafttoleranz bei Ø 6 – Ø 32 mm = h₆

Note: Toolholders suitable for induction-, contact- and hot air shrink units.
Ø 6 – Ø 32 with h₆-tolerance

Observation: Porte-outils convenables pour machines à fretter par induction,
par contact, ou par air chaud.
Ø 6 – Ø 32 avec h₆-tolerance

l₁ = max. Einstecktiefel₁ = max. clamping depthl₁ = max. profondeur d'insertionl₂ = max. Verstellwegl₂ = max. length adjustment rangel₂ = max. course de réglage

10.27

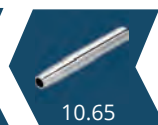

10.65



10.86

Shrink chucks 4,5° for mounting of solid carbide and HSS-tool shanks

Mandrins de frettage 4,5° pour le serrage de queues d'outils carbures de type HM et HSS



Verwendung:
Zur Aufnahme von Werkzeugen mit Zylinderschaft.

Application:
For mounting straight-shank tools.

Application:
Pour le serrage d'outils avec queue cylindrique.

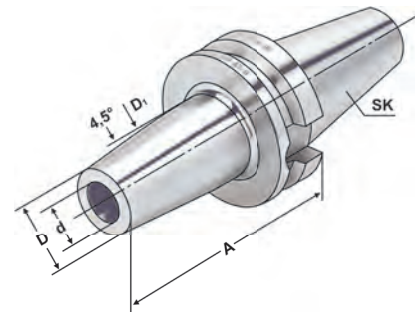

2

JIS B 6339



AD

 $\nabla \leq 0,003$ G2.5
25.000 min⁻¹

Bestell-Nr. Order no. Référence	SK	d	A	D	D ₁	l ₁	l ₂
505.71.06.2	BT 50	6	160	21	27	36	10
505.71.08.2	BT 50	8	160	21	27	36	10
505.71.10.2	BT 50	10	160	24	32	41	10
505.71.12.2	BT 50	12	160	24	32	47	10
505.71.14.2	BT 50	14	160	27	34	47	10
505.71.16.2	BT 50	16	160	27	34	50	10
505.71.18.2	BT 50	18	160	33	42	50	10
505.71.20.2	BT 50	20	160	33	42	52	10
505.71.25.2	BT 50	25	160	44	53	58	10
505.71.32.2	BT 50	32	160	44	53	62	10
505.71.06.3	BT 50	6	200	21	27	36	10
505.71.08.3	BT 50	8	200	21	27	36	10
505.71.10.3	BT 50	10	200	24	32	41	10
505.71.12.3	BT 50	12	200	24	32	47	10
505.71.14.3	BT 50	14	200	27	34	47	10
505.71.16.3	BT 50	16	200	27	34	50	10
505.71.18.3	BT 50	18	200	33	42	50	10
505.71.20.3	BT 50	20	200	33	42	52	10
505.71.25.3	BT 50	25	200	44	53	58	10

Hinweis: Aufnahme für Induktiv-, Kontakt- und Heißluftschrimpferäte geeignet.
Schafttoleranz bei Ø 6 - Ø 32 mm = h₆

Note: *Toolholders suitable for induction-, contact- and hot air shrink units.
Ø 6 - Ø 32 with h₆-tolerance*

Observation: Porte-outils convenables pour machines à frotter par induction, par contact, ou par air chaud.
Ø 6 - Ø 32 avec h₆-tolerance

l₁ = max. Einstecktiefe
l₁ = max. clamping depth

l₁ = max. profondeur d'insertion

l₂ = max. Verstellweg
l₂ = max. length adjustment range
l₂ = max. course de réglage





Shrink chucks 4,5° for mounting of solid carbide and HSS-tool shanks

Mandrins de frettage 4,5° pour le serrage de queues d'outils carbures de type HM et HSS

2

**Verwendung:**

Zur Aufnahme von Werkzeugen mit Zylinderschaft.

Application:

For mounting straight-shank tools.

Application:

Pour le serrage d'outils avec queue cylindrique.

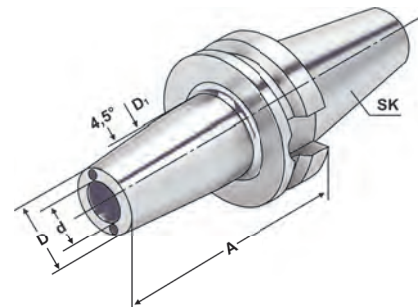

JIS B 6339



AD/B

 $\nabla \leq 0,003$ G2,5
25.000 min⁻¹

Bestell-Nr. Order no. Référence	SK	d	A	D	D ₁	l ₁	l ₂
406.70.06.K	BT 40	6	90	21	27	36	10
406.70.08.K	BT 40	8	90	21	27	36	10
406.70.10.K	BT 40	10	90	24	32	41	10
406.70.12.K	BT 40	12	90	24	32	47	10
406.70.14.K	BT 40	14	90	27	34	47	10
406.70.16.K	BT 40	16	90	27	34	50	10
406.70.18.K	BT 40	18	90	33	42	50	10
406.70.20.K	BT 40	20	90	33	42	52	10
406.70.25.K	BT 40	25	100	44	53	58	10
506.71.06.K	BT 50	6	100	21	27	36	10
506.71.08.K	BT 50	8	100	21	27	36	10
506.71.10.K	BT 50	10	100	24	32	41	10
506.71.12.K	BT 50	12	100	24	32	47	10
506.71.14.K	BT 50	14	100	27	34	47	10
506.71.16.K	BT 50	16	100	27	34	50	10
506.71.18.K	BT 50	18	110	33	42	50	10
506.71.20.K	BT 50	20	110	33	42	52	10

Hinweis: Aufnahme für Induktiv-, Kontakt- und Heißluftschrimpferäte geeignet.
Schafttoleranz bei Ø 6 – Ø 25 mm = h₆

Note: Toolholders suitable for induction-, contact- and hot air shrink units.
Ø 6 – Ø 25 with h₆-tolerance

Observation: Porte-outils convenables pour machines à frotter par induction,
par contact, ou par air chaud.
Ø 6 – Ø 25 avec h₆-tolerance

l₁ = max. Einstecktiefel₁ = max. clamping depthl₁ = max. profondeur d'insertionl₂ = max. Verstellwegl₂ = max. length adjustment rangel₂ = max. course de réglage

10.27

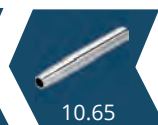

10.65



10.86

Shrink fit extensions (with end stop)
Rallonges de frettage (avec butée)

(MAS 403 BT)



Verwendung:
Zur Aufnahme von Werkzeugen mit Zylinderschaft.
Application:
For mounting straight-shank tools.
Application:
Pour le serrage d'outils avec queue cylindrique.

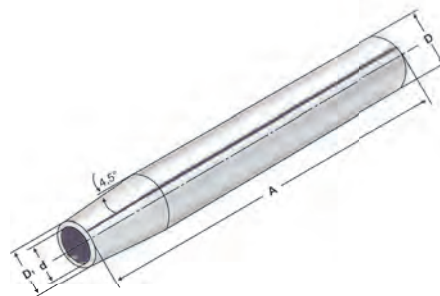

2



Bestell-Nr. Order no. Référence	D	d	D ₁	A	l ₁	l ₂
120.70.03	20	3	10	150	15	5
120.70.04	20	4	10	150	20	5
120.70.05	20	5	10	150	20	5
120.70.06*	20	6	10	150	36	10
120.70.08*	20	8	12	150	36	10
120.70.10*	20	10	14	150	42	10
120.70.12*	20	12	16	150	47	10

* mit Anschlag | * with end stop | * avec butée

Für Ø 3, 4 und 5 mm nur Hartmetallschäfte verwenden!
For Ø 3, 4 and 5 mm only solid carbide tool shanks must be used!
Pour Ø 3, 4 et 5 mm il faut seulement utiliser de queues d'outils carbures de type HM!

Hinweis: Aufnahmen für Induktiv-, Kontakt- und Heißluftschumpfergeräte geeignet.
Schafttoleranz bei Ø 3, 4 und 5 mm = h₄, bei Ø 6 - Ø 32 mm = h₆

Note: Toolholders suitable for induction-, contact- and hot air shrink units.
Ø 3, 4, 5 with h₄-tolerance and Ø 6 - Ø 32 with h₆-tolerance

Observation: Porte-outils convenables pour machines à fretter par induction, par contact, ou par air chaud.
Ø 3, 4, 5 avec h₄-tolerance et Ø 6 - Ø 32 avec h₆-tolerance

l₁ = max. Einstecktiefe
l₁ = max. clamping depth
l₁ = max. profondeur d'insertion

l₂ = max. Verstellweg
l₂ = max. length adjustment range
l₂ = max. course de réglage



2



Verwendung:
Zur Aufnahme von Einschraubfräser mit Gewinde.

Application:
For mounting screw-in cutters with thread.

Application:
Pour le serrage de fraises à queue fileté.

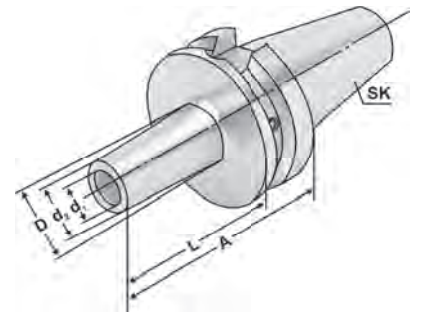

JIS B 6339 AD/B $\sqrt{\text{Ra}} \leq 0,003$ G6,3 15.000 min⁻¹

Bestell-Nr. Order no. Référence	SK	M	d ₁ ^{H4}	d ₂	D	A	L
406.06.06	BT 40	6	6,5	10	13	52	25
406.06.06.1	BT 40	6	6,5	10	20	77	50
406.06.06.2	BT 40	6	6,5	10	23	102	75
406.06.08	BT 40	8	8,5	13	15	52	25
406.06.08.1	BT 40	8	8,5	13	23	77	50
406.06.08.2	BT 40	8	8,5	13	23	102	75
406.06.08.3	BT 40	8	8,5	13	25	127	100
406.06.10	BT 40	10	10,5	18	20	52	25
406.06.10.1	BT 40	10	10,5	18	23	77	50
406.06.10.2	BT 40	10	10,5	18	28	102	75
406.06.10.3	BT 40	10	10,5	18	32	127	100
406.06.12	BT 40	12	12,5	21	24	52	25
406.06.12.1	BT 40	12	12,5	21	24	77	50
406.06.12.2	BT 40	12	12,5	21	31	102	75
406.06.12.3	BT 40	12	12,5	21	33	127	100
406.06.12.4	BT 40	12	12,5	21	36	152	125
406.06.16	BT 40	16	17	29	29	52	25
406.06.16.1	BT 40	16	17	29	34	77	50
406.06.16.2	BT 40	16	17	29	34	102	75
406.06.16.3	BT 40	16	17	29	36	127	100
406.06.16.4	BT 40	16	17	29	40	152	125
406.06.16.5	BT 40	16	17	29	42	177	150
506.06.08.1	BT 50	8	8,5	13	23	88	50
506.06.08.3	BT 50	8	8,5	13	25	138	100
506.06.08.5	BT 50	8	8,5	13	30	188	150
506.06.10.1	BT 50	10	10,5	18	23	88	50
506.06.10.3	BT 50	10	10,5	18	32	138	100
506.06.10.5	BT 50	10	10,5	18	37	188	150
506.06.12.1	BT 50	12	12,5	21	24	88	50
506.06.12.3	BT 50	12	12,5	21	33	138	100
506.06.12.5	BT 50	12	12,5	21	40	188	150
506.06.16.1	BT 50	16	17	29	34	88	50
506.06.16.2	BT 50	16	17	29	36	113	75
506.06.16.3	BT 50	16	17	29	36	138	100
506.06.16.5	BT 50	16	17	29	43	188	150

Test arbors
Mandrins de contrôle

(MAS 403 BT)



Verwendung:
Zur Abnahme von Werkzeugmaschinen gemäß ISO-Empfehlung R230 oder zur Überprüfung der Werkzeugspindel.

Application:
For the inspection of machine tools according to ISO recommendation R230 or for testing the tool spindle.

Application:
Pour l'inspection de machine-outils suite à la recommandation ISO R230 ou pour la vérification de la broche.

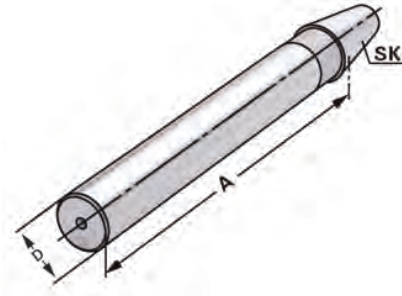

JIS B 6339 Form A $\nabla \leq 0,003$

Bestell-Nr. Order no. Référence	SK	A	D	Toleranz Tolerance Tolérance	max. Rundlaufabweichung max. concentricity deviation Faux-rond max.
305.18.32	BT 30	300	32	0,003	0,003
405.18.40	BT 40	300	40	0,003	0,003
505.18.50	BT 50	300	50	0,003	0,003

Lieferumfang: Auslieferung mit Prüfprotokoll
Delivery: *Delivery with test certificate*
Livraison: Livraison avec rapport d essais

Holzkasten für Kontrolldorne

Wooden box for test arbors
Coffret en bois pour mandrins de contrôle



Verwendung:
Zur Aufbewahrung von Kontrolldornen.

Application:
For the storage of test arbors.

Application:
Pour la conservation de mandrins de contrôle.



Bestell-Nr. Order no. Référence	Abmessung Size Dimension	für Kegelgrößen for cones pour cônes
701.18	460 × 130 × 115	BT 30 / 40 / 50

*WERKZEUGAUFNAHMEN
MIT PLANANLAGE
BT30 und BT40*

*TOOLHOLDERS
DUAL CONTACT
BT30 and BT40*

*PORTE-OUTILS
CONTACT DIRECT
BT30 et BT40*

DC BT30 & BT40

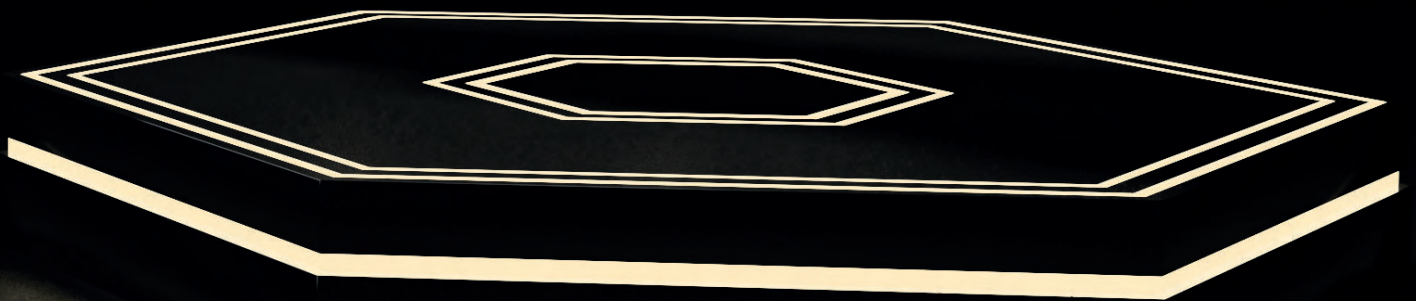

Toolholders Dual Contact
 Porte-outils Contact direct

Vorgewuchtet
Pre-balanced
 Pré-équilibré

G 6,3 15.000 min⁻¹

G 2,5 Feinwuchten gegen Aufpreis
G 2.5 Fine balancing at extra charge
 G 2,5 Equilibrage fin contre un supplément

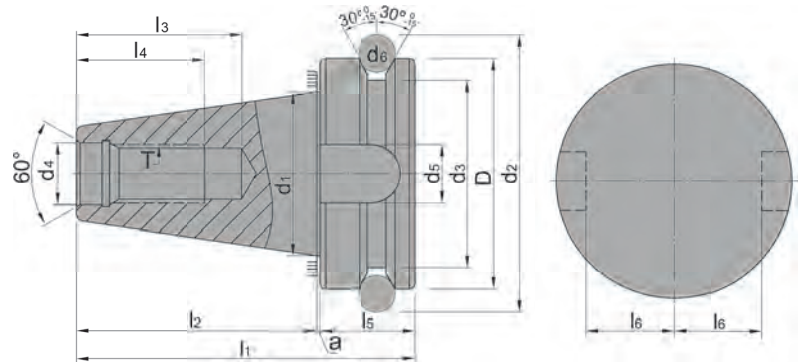

SK	d ₁	d ₂	T	d ₄	D	a	l ₁	l ₂	l ₃	l ₄	l ₅	l ₆	e	d ₃	d ₅	d ₆
30	31,75	56,14	M12	12,5	46	1	70,4	48,4	34	24	21	16	-	38	16,1	8
40	44,45	75,679	M16	17,0	63	1	92,4	65,4	43	30	26	22,6	27	53	16,1	10
50	69,85	119,02	M24	25,0	100	1,5	139,8	101,8	62	45	36,5	35,4	42	85	25,7	15

Mit innerer Kühlmittelzufuhr über den Bund - Form AD/B

With internal coolant through the collar - form AD/B
 Avec arrosage interne par la collerette - forme AD/B

Bei Lieferung mit Gewindestiften verschlossen
Delivery with headless screws in closed position
 Livraison en état fermé avec de vis sans tête

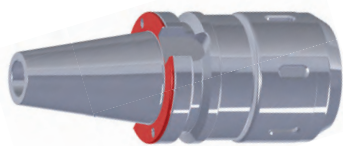
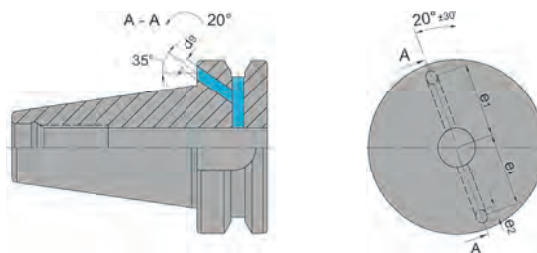

Werkstoff: Legierter Einsatzstahl mit einer Zugfestigkeit im Kern von min. 800 N / mm². Einsatzgehärtet HRC 60 ± 2 (HV 700 ± 50), Härtetiefe 0,8 mm ± 0,2 mm, brüniert und präzisionsgeschliffen.

Form AD/B: Lieferung in Ausführung AD, Form B mit lösbaren Gewindestiften verschlossen.

Genauigkeit: Kegelwinkel - Toleranzqualität < AT 3 nach DIN 7187 und DIN 2080.

Material: Alloyed case-hardened steel, tensile core strength of min. 800 N / mm². Case hardened HRC 60 ± 2 (HV 700 ± 50), hardening depth 0.8 mm ± 0.2 mm, black-finished and precisely grinded.

Form AD/B: Delivery in form AD, type B closed with releasable headless screws.

Accuracy: Quality of taper < AT 3 according to DIN 7187 and DIN 2080.

Matière: Acier de cémentation allié. Résistance à la traction dans le noyau de min 800 N / mm². Cémentation à HRC 60 ± 2 (HV 700 ± 50), profondeur de cémentation 0,8 mm ± 0,2 mm, bruni et rectifié précisément.

Forme AD/B: Livraison en forme AD, forme B fermée avec des vis amovibles sans tête.

Précision: Qualité du cône < AT 3 selon DIN 7187 et DIN 2080.

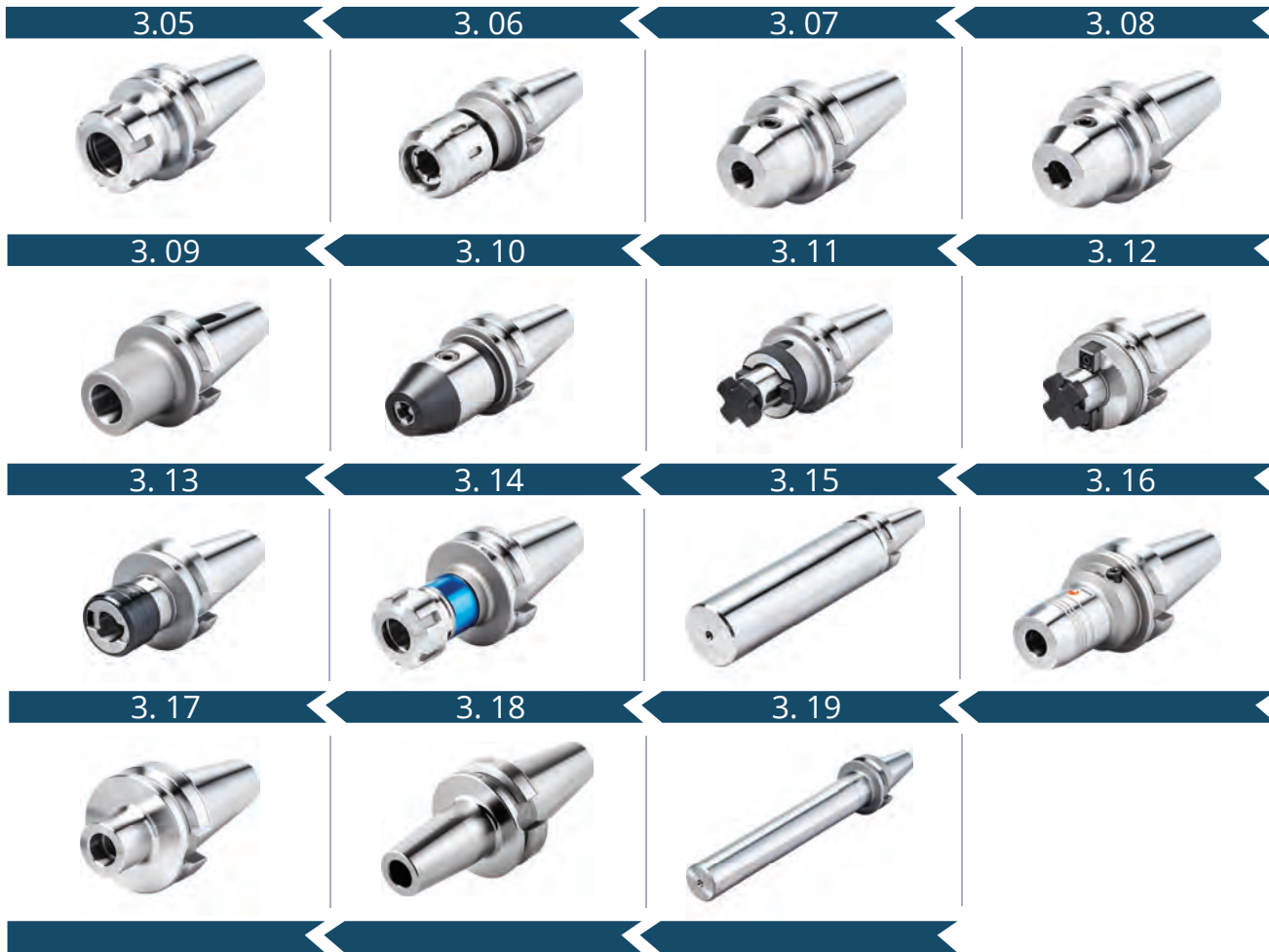

DIN69871 mit Plananlage auf Anfrage kurzfristig lieferbar.
 DIN69871 with dual contact available within a short period upon request.
 DIN69871 avec contact direct livrables dans un délai court sur demande.





Collet chucks for collets DIN 6499 (ISO 15488) ER-system
Mandrins à pinces pour pinces DIN 6499 (ISO 15488) système ER



Verwendung:
Zur Aufnahme von Werkzeugen mit
Zylinderschaft in Spannzangen.

Application:
For mounting straight-shank tools in collets.

Application:
Pour le serrage d'outils avec queue
cylindrique dans des pinces de serrage.

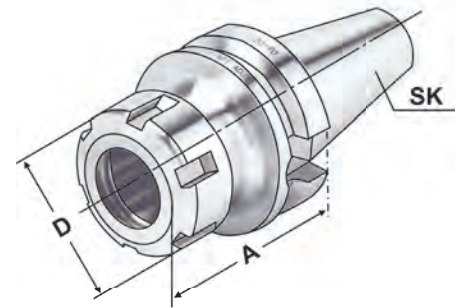

3

JIS B 6339



AD/B

 $\nearrow \leq 0,003$ G6.3
15.000 min⁻¹

Bestell-Nr. Order no. Référence	SK	Spannbereich Capacity Capacité	A	D
DC.305.02.10 *	BT 30	1 – 10 (ER 16)	70	32
DC.305.02.16 *	BT 30	2 – 16 (ER 25)	70	42
DC.305.02.20 *	BT 30	2 – 20 (ER 32)	70	50
DC.305.02.26 *	BT 30	3 – 26 (ER 40)	70	63
DC.406.02.10	BT 40	1 – 10 (ER 16)	63	32
DC.406.02.16	BT 40	2 – 16 (ER 25)	60	42
DC.406.02.20	BT 40	2 – 20 (ER 32)	70	50
DC.406.02.26	BT 40	3 – 26 (ER 40)	80	63
DC.406.02.10.1	BT 40	1 – 10 (ER 16)	100	32
DC.406.02.16.1	BT 40	2 – 16 (ER 25)	100	42
DC.406.02.20.1	BT 40	2 – 20 (ER 32)	100	50
DC.406.02.26.1	BT 40	3 – 26 (ER 40)	100	63
DC.406.02.10.2	BT 40	1 – 10 (ER 16)	160	32
DC.406.02.16.2	BT 40	2 – 16 (ER 25)	160	42
DC.406.02.20.2	BT 40	2 – 20 (ER 32)	160	50
DC.406.02.26.2	BT 40	3 – 26 (ER 40)	160	63

* JIS B 6339 Form AD

* JIS B 6339 form AD

* JIS B 6339 forme AD

Lieferumfang: Mit gewuchteter Spannmutter
Delivery: With balanced clamping nut
Livraison: Avec écrou de serrage équilibré



9.03



10.11



10.22



10.27



High Performance Milling Chuck HKS-system
Mandrin de serrage à haute performance système HKS



Verwendung:

Zur Aufnahme von Werkzeugen mit Zylinder-
 schaft nach DIN 1835 Form A+B+E und DIN
 6535 Form HB+HE (größer Ø 20 mm nur mit
 Reduzierung).

Application:

For mounting straight-shank tools acc. DIN 1835
 form A+B+E and DIN 6535 form HB+HE
 (larger than dia. 20 mm only with reduction
 sleeve).

Application:

Pour le serrage d'outils avec queue cylindrique
 suivant DIN 1835 forme A+B+E et DIN 6535
 forme HB+HE

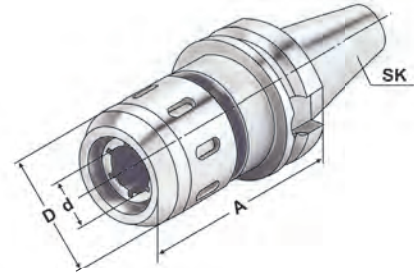

JIS B 6339 AD/B $\sqrt{\text{Ra}} \leq 0,003$ $\frac{G6,3}{15.000 \text{ min}^{-1}}$

Bestell-Nr. Order no. Référence	SK	Spannbereich Capacity Capacité	A	D	d
DC.406.64.20	BT 40	20 (HKS 20)	90	53	20
DC.406.64.25	BT 40	25 (HKS 25)	90	63	25
DC.406.64.32	BT 40	32 (HKS 32)	90	68	32





End mill holders DIN 6359 for end mills DIN 1835-B
 Porte-fraises DIN 6359 pour queues cylindriques DIN 1835-B

Dual Contact



Verwendung:
 Zum Spannen von zylindrischen Werkzeugschäften mit seitlicher Spannfläche nach DIN 1835 Form B (Weldon).

Application:
 For mounting straight-shank tools with lateral flat according to DIN 1835 form B (Weldon).

Application:
 Pour le serrage d'outils avec queue cylindrique et avec méplat suivant DIN 1835 forme B (Weldon).

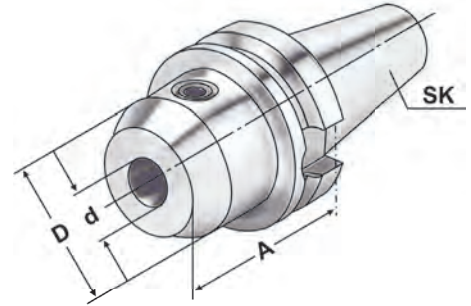

3

JIS B 6339



AD/B

 $\nabla \leq 0,003$ G6.3
15.000 min⁻¹

Bestell-Nr. Order no. Référence	SK	d ^{H4}	A	D
DC.305.04.06 *	BT 30	6	50	25
DC.305.04.08 *	BT 30	8	50	28
DC.305.04.10 *	BT 30	10	50	35
DC.305.04.12 *	BT 30	12	50	42
DC.305.04.14 *	BT 30	14	50	44
DC.305.04.16 *	BT 30	16	63	48
DC.305.04.18 *	BT 30	18	63	50
DC.305.04.20 *	BT 30	20	63	52
DC.406.04.06	BT 40	6	50	25
DC.406.04.08	BT 40	8	50	28
DC.406.04.10	BT 40	10	63	35
DC.406.04.12	BT 40	12	63	42
DC.406.04.14	BT 40	14	63	44
DC.406.04.16	BT 40	16	63	48
DC.406.04.18	BT 40	18	63	50
DC.406.04.20	BT 40	20	63	52
DC.406.04.25	BT 40	25	90	65
DC.406.04.32	BT 40	32	100	72
DC.406.04.40	BT 40	40	120	80
DC.406.04.06.1	BT 40	6	100	25
DC.406.04.08.1	BT 40	8	100	28
DC.406.04.10.1	BT 40	10	100	35
DC.406.04.12.1	BT 40	12	100	42
DC.406.04.14.1	BT 40	14	100	44
DC.406.04.16.1	BT 40	16	100	48
DC.406.04.18.1	BT 40	18	100	50
DC.406.04.20.1	BT 40	20	100	52

* JIS B 6339 Form AD

* JIS B 6339 form AD

* JIS B 6339 forme AD



10.52



10.27

End mill holders DIN 6359 with coolant channels for end mills DIN 1835-B
 Porte-fraises DIN 6359 avec canaux d'arrosage pour queues cylindriques DIN 1835-B

**Verwendung:**

Zum Spannen von zylindrischen Werkzeugschäften mit seitlicher Spannfläche nach DIN 1835 Form B (Weldon). Mit Kühlkanälen für optimale Kühlung der Werkzeugschneide.

Application:

For mounting straight-shank tools with lateral flat according to DIN 1835 form B (Weldon). With coolant channels for optimal coolant at the cutting edge.

Application:

Pour le serrage d'outils avec queue cylindrique et avec méplat suivant DIN 1835 forme B (Weldon). Avec canaux d'arrosage pour un refroidissement optimal aux lames.

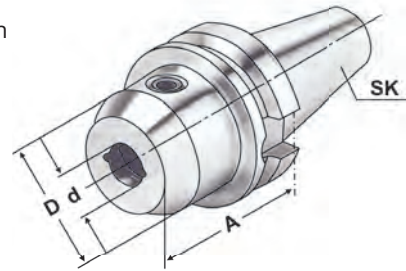

JIS B 6339



AD/B

 $\lambda \leq 0,003$ G6,3
15.000 min⁻¹

Bestell-Nr.
Order no.
Référence

SK

d^{H4}

A

D

DC.406.04.06.K	BT 40	6	50	25
DC.406.04.08.K	BT 40	8	50	28
DC.406.04.10.K	BT 40	10	63	35
DC.406.04.12.K	BT 40	12	63	42
DC.406.04.14.K	BT 40	14	63	44
DC.406.04.16.K	BT 40	16	63	48
DC.406.04.18.K	BT 40	18	63	50
DC.406.04.20.K	BT 40	20	63	52

Hinweis:

Ab d = 25 mit zwei Spannschrauben
 d = 6 bis 18 mit zwei Kühlkanälen
 d = 20 bis 20 mit vier Kühlkanälen

Für Werkzeuge mit innerer Kühlmittelzufuhr muss ein O-Ring eingesetzt werden.

Note:

From d = 25 on two clamping screws
 d = 6 to 18 with two coolant channels
 d = 20 to 20 with four coolant channels

For tools with through coolant an O-ring must be used.

Observation:

A partir de d = 25 avec deux vis de serrage
 d = 6 bis 18 avec deux canaux d'arrosage
 d = 20 bis 20 avec quatre canaux d'arrosage

Pour outils avec arrosage interne il faut utiliser un joint torique.

Lieferumfang:

Mit Spannschraube und O-Ring

Delivery:

With clamping screw and O-ring

Livraison:

Avec vis de serrage et joint torique





Verwendung:
Zur Aufnahme von Werkzeugen mit Morsekegelschaft und Austreibblappen nach DIN 228-1 Form B.

Application:
For mounting tools with Morse taper shank and tang according to DIN 228-1 form B.

Application:
Pour le serrage d'outils avec queue cône Morse et tenon suivant DIN 228-1 forme B.

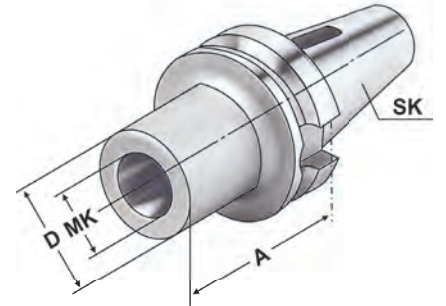

JIS B 6339 AD/B $\nearrow \leq 0,005$ G6,3 15.000 min⁻¹

Bestell-Nr. Order no. Référence	SK	MK MT CM	A	D
DC.305.07.01 *	BT 30	1	45	25
DC.305.07.02 *	BT 30	2	60	32
DC.305.07.03 *	BT 30	3	75	40
DC.406.07.01	BT 40	1	50	25
DC.406.07.02	BT 40	2	50	32
DC.406.07.03	BT 40	3	70	40
DC.406.07.04	BT 40	4	95	48

- * JIS B 6339 Form AD
- * JIS B 6339 form AD
- * JIS B 6339 forme AD

Gewuchtete Ausführung



Balanced type
Type équilibré

Bestell-Nr. Order no. Référence	Abmessung Size Dimension
---------------------------------------	--------------------------------

Wuchten auf G 2,5 von vorgewuchteten Kemmler-Werkzeugen
Balancing at G 2.5 of pre-balanced Kemmler-tools
Équilibrage sur G 2,5 d'outils Kemmler pré-équilibrés

W25 **Ohne Wuchtprotokoll**
Without balancing report
Sans protocole d'équilibrage

W25.2 **Mit Wuchtprotokoll**
With balancing report
Avec protocole d'équilibrage

Wuchten von nicht vorgewuchteten Werkzeugen
Balancing of unbalanced tools
Équilibrage d'outils non-équilibrés

W25.1 **Ohne Wuchtprotokoll**
Without balancing report
Sans protocole d'équilibrage





CNC-Drill chucks for clockwise and counter clockwise rotation
Mandrins de perçage CNC pour rotation gauche-droite

Dual Contact



Verwendung:
Zur Aufnahme von Werkzeugen mit Zylinderschaft.
Application:
For mounting tools with straight shanks.
Application:
Pour le serrage d'outils avec queue cylindrique.

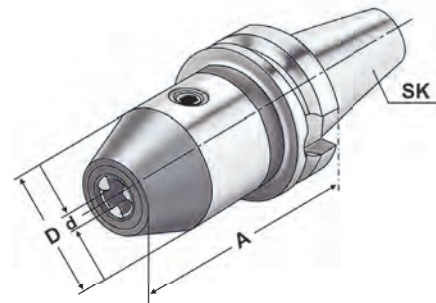

JIS B 6339 AD/B $\leq 0,030$ $G6,3$ 15.000 min^{-1}

Bestell-Nr. Order no. Référence	SK	Spannbereich Capacity Capacité	A	D
DC.305.15.13 *	BT 30	1,0 – 13	93	50
DC.305.15.16 *	BT 30	2,5 – 16	98	50
DC.406.15.13	BT 40	1,0 – 13	98	50
DC.406.15.16	BT 40	2,5 – 16	103	50

* JIS B 6339 Form AD
* JIS B 6339 form AD
* JIS B 6339 forme AD

Hinweis: Hohe Präzision und Rundlaufgenauigkeit von $\leq 0,03$ mm. Sichere Spannung des Werkzeuges durch mechanische Spannkraftverstärkung. Kein selbständiges Lösen der Spannung während der Bearbeitung bei Links- oder Rechtslauf, sowie bei Spindelstop. Spannen und Lösen mit Sechskantschlüssel.

Note: High precision and accurate concentricity of ≤ 0.03 mm. Secure gripping of the tool through mechanical amplification of the clamping force. No automatic slacking of the clamping force while machining with either clockwise or counter clockwise rotation or on spindle stop. Clamping and releasing effected by means of an Allen wrench.

Observation: Précision élevée et exactitude de circularité de $\leq 0,03$ mm. Serrage sûr de l'outil grâce à l'amplification de la force de serrage. Pas de desserrage intempestif en cours d'usinage lors de la rotation la gauche ou la droite, de même qu'en cas d'arrêt de la broche. Serrage et desserrage en utilisant un clé sur à fourche.

Lieferumfang: Mit Spannschlüssel
Delivery: With wrench
Livraison: Avec clé de serrage





Verwendung:
Zur Aufnahme von Walzen-, Walzenstirnfräsern oder Messerköpfen mit Längs- oder Quernut.

Application:
For mounting milling cutters with transverse or longitudinal groove.

Application:
Pour le serrage de fraises à rainure transversale ou à rainure longitudinale.

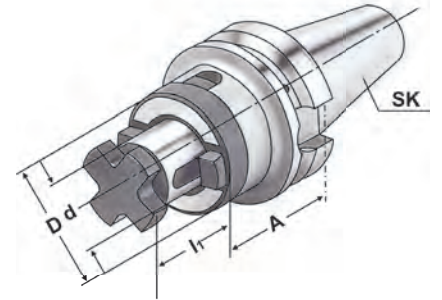

3

JIS B 6339



AD/B

$\nabla \leq 0,005$

G6,3
15.000 min⁻¹

Bestell-Nr. Order no. Référence	SK	d _{h6}	A	l ₁	D
DC.305.10.16 *	BT 30	16	45	17	32
DC.305.10.22 *	BT 30	22	47	19	40
DC.305.10.27 *	BT 30	27	49	21	48
DC.406.10.16	BT 40	16	55	17	32
DC.406.10.22	BT 40	22	55	19	40
DC.406.10.27	BT 40	27	55	21	48

* JIS B 6339 Form AD

* JIS B 6339 form AD

* JIS B 6339 forme AD

Lieferumfang: Mit Fräseranzugsschraube, Mitnehmerring und Passfeder
Delivery: With tightening bolt, driving ring and feather key
Livraison: Avec vis de blocage, bague d'entraînement et clavette



Shell mill holders DIN 6357 with enlarged contact face and coolant exit bores on the end face
 Porte-fraises à trou lisse DIN 6357 avec face de contact élargie et conduits pour l'arrosage frontal



Verwendung:
 Zur Aufnahme von Messerköpfen und Fräsern mit Quernut.

Application:
 For mounting milling cutters with transversal groove.

Application:
 Pour le serrage de fraises à rainure transversale.

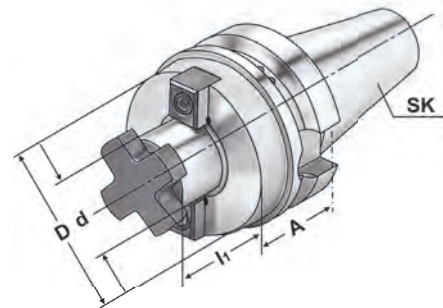

JIS B 6339 AD/B $\leq 0,005$ G6,3 15.000 min⁻¹

Bestell-Nr. Order no. Référence	SK	d _{H6}	A	l ₁	D
DC.305.11.16 *	BT 30	16	40	17	38
DC.305.11.22 *	BT 30	22	40	19	48
DC.305.11.27 *	BT 30	27	40	21	58
DC.305.11.32 *	BT 30	32	50	24	78
DC.406.11.16	BT 40	16	40	17	38
DC.406.11.22	BT 40	22	40	19	48
DC.406.11.27	BT 40	27	40	21	58
DC.406.11.32	BT 40	32	50	24	78
DC.406.11.40	BT 40	40	50	27	88
DC.406.11.16.1	BT 40	16	100	17	38
DC.406.11.22.1	BT 40	22	100	19	48
DC.406.11.27.1	BT 40	27	100	21	58

d = 40/d = 60: Für große Planfräser mit vier zusätzlichen Gewindebohrungen nach DIN 2079.
 For large diameter face mill cutters with four additional threaded holes according to DIN 2079.
 Pour fraises à surfacer à grands diamètres avec quatre trous taraudés additionnels suivant DIN 2079.

Lieferumfang: Mit Mitnehmersteinen, Kreuzschraube und Zylinderkopfschraube nach DIN 912 für Fräser mit innerer Kühlmittelzufuhr.
 Bei d = 60 nur mit vier Befestigungsschrauben nach DIN 912.

Delivery: With drivers, cross head retaining screw and cylinder head retaining screw for cutters with central coolant.
 For d = 60 only with four fixation screws according to DIN 912.

Livraison: Avec tenons, une vis cruciforme et une vis à tête cylindrique suivant DIN 912 pour fraises avec arrosage central.
 Pour d = 60 seulement avec quatre vis de fixation suivant DIN 912.



* JIS B 6339 Form AD | BT 30 ohne Kühlkanalbohrungen an der Stirnseite
 * JIS B 6339 form AD | BT 30 without coolant exit bores on the end face
 * JIS B 6339 forme AD | BT 30 sans alésages pour l'arrosage frontal





Quick change tapping chucks with length compensation on compression and expansion

Mandrins de taraudage à changement rapide avec compensation longitudinale à la compression et traction



Verwendung:
Zur Aufnahme von Schnellwechsel-Einsätzen für Gewindebohrer.

Application:
For the chucking of quick change adaptors for taps.

Application:
Pour le serrage d'adaptateurs porte-tarauds à changement rapide.

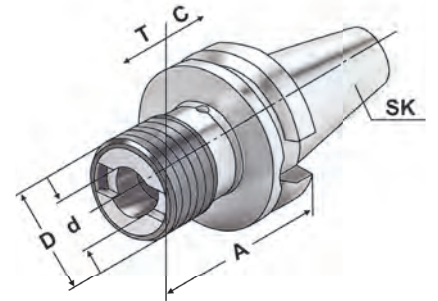

3

JIS B 6339

Form A

Bestell-Nr. Order no. Référence	SK	Spannbereich Capacity Capacité	Größe Size Taille	A	D	d	C	T
DC.405.16.12	BT 40	M3 - M14	1	65	38	19	7	7
DC.405.16.20	BT 40	M5 - M22	2	93	54	31	12	12

Hinweis: Für Bearbeitungszentren ohne Synchronspindel.
Note: For machining centres without synchronous spindle.
Observation: Pour centres d'usinage sans broche synchrone.



Tapping chucks for synchronisation for collets DIN 6499 (ISO 15488) ER-system
Mandrins de taraudage pour synchronisation pour pinces DIN 6499 (ISO 15488) système ER



Verwendung:
Für Bearbeitungszentren mit Synchronspindel.
Application:
For machining centres with synchronous spindle.
Application:
Pour centres d'usinage avec broche synchrone.

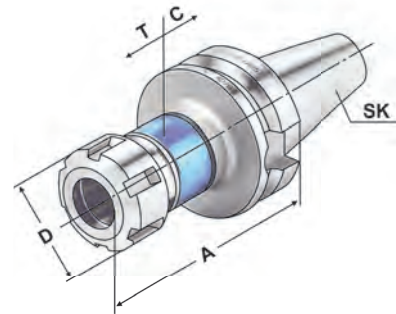

JIS B 6339 AD/B $\leq 0,060$ 15.000 min^{-1}

Bestell-Nr. Order no. Référence	SK	Spannbereich Capacity Capacité	A	D	T	C
DC.406.16.02.10 *	BT 40	M3 – M12 (ER 16) SW25	81	28	0,5	0,5
DC.406.16.02.16	BT 40	M3 – M20 (ER 25)	89	42	0,5	0,5
DC.406.16.02.20	BT 40	M3 – M27 (ER 32)	110	50	0,5	0,5

* Sechskantmutter
* Hexagonal clamping nut
* Écrous hexagonal

- Hinweis:**
- Synchro-Gewindeschneidfutter kompensieren Synchronisationsfehler.
 - Minimallängenausgleich in Druck- und Zugrichtung zwischen Synchronspindel und Gewindebohrer reduziert zu hohe Gewindeflankenreibungskräfte.
 - Reduziert eventuelle Axialkraftehöhung während des Schneidzyklus auf ein Minimum.
 - Geeignet für Innenkühlung.
 - Kühlmitteldruck max. 100 bar.

- Note:**
- *Synchro tapping chucks compensate synchronisation errors.*
 - *Minimal length compensation on compression and expansion balances very small pitch differences between synchro spindle and tap, which can cause high frictional forces on the thread flanks.*
 - *A possible increase of axial force during the tapping process is reduced to a minimum.*
 - *Suitable for internal coolant.*
 - *Coolant pressure up to max. 100 bar.*

- Observation:**
- Mandrins de taraudage version „synchro“ compensent les erreurs éventuelles de synchronisation.
 - Compensation longitudinale minimale à la compression et traction entre la broche synchronisée et le taraud réduit la friction au niveau des flancs de filets.
 - Réduit au minimum les efforts éventuelles axiaux lors du cycle de taraudage.
 - Approprié pour la lubrification centrale.
 - Pression de lubrification max. 100 bar.

Lieferumfang: Mit gewuchteter Spannmutter
Delivery: With balanced clamping nut
Livraison: Avec écrou de serrage équilibré





Verwendung:
Zur Herstellung von Sonderwerkzeugen.

Application:
For the manufacturing of special tools.

Application:
Pour la fabrication d'outils spéciaux.

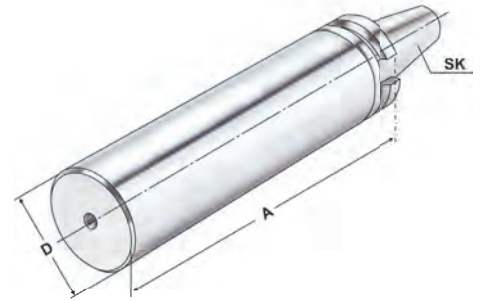

JIS B 6339 Form A

Bestell-Nr. Order no. Référence	SK	D	A
DC.305.17.40	BT 30	40,5	160
DC.405.17.63	BT 40	63	250

Ausführung: Steilkegel und Bund gehärtet und geschliffen. Schaft weich zur weiteren Bearbeitung.
Version: *Cone and flange hardened and grinded. Soft body for later processing.*
Version: Cône et collerette durcis et rectifiés. Corps doux pour un usinage ultérieur.





Verwendung:
Zur Aufnahme von Werkzeugen mit Zylinderschaft nach DIN 1835 Form A+B+E und DIN 6535 Form HB+HE (größer Ø 20 mm nur mit Reduzierung).

Application:
For mounting straight-shank tools acc. DIN 1835 form A+B+E and DIN 6535 form HB+HE (larger than Ø 20 mm only with reduction sleeve).

Application:
Pour le serrage d'outils avec queue cylindrique suivant DIN 1835 forme A+B+E et DIN 6535 forme HB+HE (à partir de Ø 20 mm seulement avec réduction).

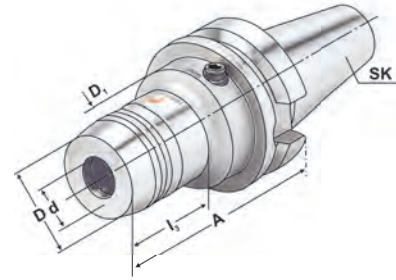

JIS B 6339 AD $\nabla \leq 0,003$ G6.3 15.000 min⁻¹

Bestell-Nr. Order no. Référence	SK	d	A	D	D ₁	l ₁	l ₂	l ₃
DC.305.H06	BT 30	6	60	26	45	37	10	33
DC.305.H08	BT 30	8	64	28	45	37	10	29
DC.305.H10	BT 30	10	64	30	45	42	10	37
DC.305.H12	BT 30	12	72	32	45	47	10	43
DC.305.H16	BT 30	16	90	38	45	52	10	47
DC.305.H20	BT 30	20	90	42	45	52	10	68
DC.405.H06	BT 40	6	90	26	50	37	10	43
DC.405.H08	BT 40	8	90	28	50	37	10	43,5
DC.405.H10	BT 40	10	90	30	50	42	10	44
DC.405.H12	BT 40	12	90	32	50	47	10	44,5
DC.405.H14	BT 40	14	90	34	50	47	10	47,5
DC.405.H16	BT 40	16	90	38	50	52	10	47,5
DC.405.H18	BT 40	18	90	40	50	52	10	47,5
DC.405.H20	BT 40	20	90	42	50	52	10	47,5
DC.405.H25	BT 40	25	90	50	63	58	10	51
DC.405.H32	BT 40	32	110	60	60	62	10	81,5

Lieferumfang: Mit Spanschlüssel
Delivery: With wrench
Livraison: Avec clé de serrage

l₁ = max. Einstecktiefe l₂ = max. Verstellweg
l₁ = max. clamping depth l₂ = max. length adjustment range
l₁ = max. profondeur d'insertion l₂ = max. course de réglage





Verwendung:
Zur Aufnahme von Einschraubfräser mit Gewinde.

Application:
For mounting screw-in cutters with thread.

Application:
Pour le serrage de fraises à queue filetée.

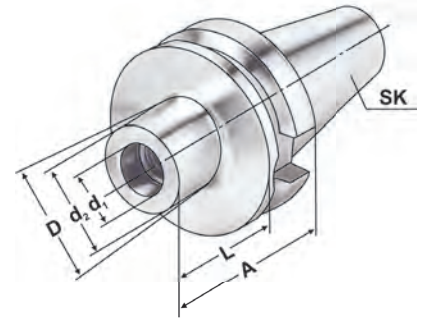

3

JIS B 6339



AD/B

$\nabla \leq 0,003$

G6,3
15.000 min⁻¹

Bestell-Nr. Order no. Référence	SK	M	d ₁ ^{H4}	d ₂	D	A	L
DC.406.06.12	BT 40	12	12,5	21	24	52	25
DC.406.06.12.2	BT 40	12	12,5	21	31	102	75
DC.406.06.12.3	BT 40	12	12,5	21	33	127	100
DC.406.06.16	BT 40	16	17	29	29	52	25
DC.406.06.16.1	BT 40	16	17	29	34	77	50
DC.406.06.16.2	BT 40	16	17	29	34	102	75
DC.406.06.16.3	BT 40	16	17	29	36	127	100



10.27

Shrink chucks 4,5° for mounting of solid carbide and HSS-tool shanks

Mandrins de frettage 4,5° pour le serrage de queues d'outils carbures de type HM et HSS



Verwendung:
Zur Aufnahme von Werkzeugen mit
Zylinderschaft.

Application:
For mounting straight-shank tools.

Application:
Pour le serrage d'outils avec queue
cylindrique.

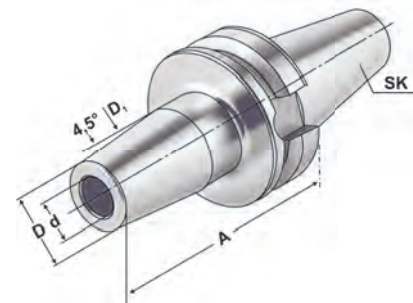

JIS B 6339

 $\nabla \leq 0,003$ G2,5
25.000 min⁻¹

Bestell-Nr. Order no. Référence	SK	d	A	D	D ₁	l ₁	l ₂
DC.305.70.03	BT 30	3	80	11	15	10	-
DC.305.70.04	BT 30	4	80	14	22	20	5
DC.305.70.05	BT 30	5	80	16	22	20	5
DC.305.70.06	BT 30	6	80	21	27	36	10
DC.305.70.08	BT 30	8	80	21	27	36	10
DC.305.70.10	BT 30	10	80	24	32	42	10
DC.305.70.12	BT 30	12	90	24	32	47	10
DC.305.70.14	BT 30	14	90	27	34	47	10
DC.305.70.16	BT 30	16	90	27	34	50	10
DC.305.70.18	BT 30	18	90	33	42	50	10
DC.305.70.20	BT 30	20	90	33	42	52	10
DC.406.70.03	BT 40	3	80	11	15	10	-
DC.406.70.04	BT 40	4	80	14	22	20	5
DC.406.70.05	BT 40	5	80	16	22	20	5
DC.406.70.06	BT 40	6	90	21	27	36	10
DC.406.70.08	BT 40	8	90	21	27	36	10
DC.406.70.10	BT 40	10	90	24	32	41	10
DC.406.70.12	BT 40	12	90	24	32	47	10
DC.406.70.14	BT 40	14	90	27	34	47	10
DC.406.70.16	BT 40	16	90	27	34	50	10
DC.406.70.18	BT 40	18	90	33	42	50	10
DC.406.70.20	BT 40	20	90	33	42	52	10
DC.406.70.25	BT 40	25	100	44	53	58	10
DC.406.70.32	BT 40	32	100	44	53	58	10
DC.406.70.06.1	BT 40	6	120	21	27	36	10
DC.406.70.08.1	BT 40	8	120	21	27	36	10
DC.406.70.10.1	BT 40	10	120	24	32	41	10
DC.406.70.12.1	BT 40	12	120	24	32	47	10
DC.406.70.14.1	BT 40	14	120	27	34	47	10
DC.406.70.16.1	BT 40	16	120	27	34	50	10
DC.406.70.20.1	BT 40	20	120	33	42	52	10

Für Ø 3, 4 und 5 mm nur Hartmetallschäfte verwenden!

For Ø 3, 4 and 5 mm only solid carbide tool shanks must be used!

Pour Ø 3, 4 et 5 mm il faut seulement utiliser de queues d'outils carbures de type HM!

l₁ = max. Einstecktiefel₁ = max. clamping depthl₁ = max. profondeur d'insertionl₂ = max. Verstellwegl₂ = max. length adjustment rangel₂ = max. course de réglage

3



Verwendung:
Zur Abnahme von Werkzeugmaschinen gemäß ISO-Empfehlung R230 oder zur Überprüfung der Werkzeugspindel.

Application:
For the inspection of machine tools according to ISO recommendation R230 or for testing the tool spindle.

Application:
Pour l'inspection de machine-outils suite à la recommandation ISO R230 ou pour la vérification de la broche.

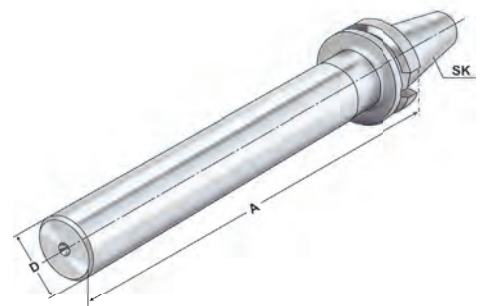

JIS B 6339 Form A $\nabla \leq 0,003$

Bestell-Nr. Order no. Référence	SK	A	D	Toleranz Tolerance Tolérance	max. Rundlaufabweichung max. concentricity deviation Faux-rond max.
DC.405.18.40	BT 40	300	40	0,003	0,003

Lieferumfang: Auslieferung mit Prüfprotokoll
Delivery: Delivery with test certificate
Livraison: Livraison avec rapport d'essais

Holzkasten für Kontrolldorne

Wooden box for test arbors
Coffret en bois pour mandrins de contrôle



Verwendung:
Zur Aufbewahrung von Kontrolldornen.

Application:
For the storage of test arbors.

Application:
Pour la conservation de mandrins de contrôle.



Bestell-Nr. Order no. Référence	Abmessung Size Dimension	für Kegelgrößen for cones pour cônes
701.18	460×130×115	BT 30 / 40 / 50



Steep taper toolholders with full face contact Porte-outils conique avec cône face

Die Vorteile sind:

- Maschinenleistung kann voll genutzt werden
- Stabile und vergrößerte, vollständige Plananlage
- Weniger Vibrationen aufgrund der großen Plananlage
- Verbesserte Oberflächengüte und prozesssichere Maßhaltigkeit am Werkstück
- Höhere Standzeit der Schneidwerkzeuge
- Bessere Werkzeugwechsel-Wiederholgenauigkeit
- Kein Stabilitätsverlust bei hohen Spindeldrehzahlen



3

The advantages are:

- Machine performance can be used to the full extent
- Stable and bigger, complete full face contact
- Less vibrations due to large full face contact
- Better surface finish and higher reliability of processing
- Longer service life of the cutting tools
- Better tool change repeat accuracy
- No loss of stability at high spindle speeds



Les avantages sont:

- La rendement de machine peut être utilisée entièrement
- Cône face entière, stable et élargi
- Moins vibrations à cause de cône face élargi
- Finition de surface améliorée et tenue des cotes fiable de la pièce usinée
- Tenue de coupe prolongée
- Exactitude de changement d'outil améliorée
- Pas de perte de stabilité à grande vitesse de la broche



*WERKZEUGAUFNAHMEN
DIN 2080*

*TOOLHOLDERS
DIN 2080*

*PORTE-OUTILS
DIN 2080*

DIN 2080

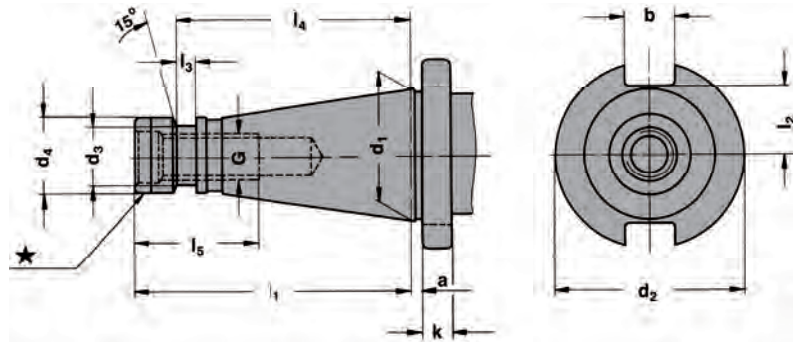

Toolholders DIN 2080
Porte-outils DIN 2080
Vorgewuchtet
Pre-balanced
Pré-équilibré
G 6,3 15.000 min⁻¹
G 2,5 Feinwuchten gegen Aufpreis
G 2.5 Fine balancing at extra charge
G 2,5 Equilibrage fin contre un supplément

- ★ **Mit Kunststoff-Kantenschutzring**
- ★ *With plastic protection ring*
- ★ *Avec bague de protection en plastique*

4

SK	d ₁	a	b	k	G	d ₂	d ₃	d ₄	l ₁	l ₂	l ₃	l ₄	l ₅
30	31,75	1,6	16,1	8	M12	50,0	-	17,2	68,4	16,2	-	-	24,0
40 ★	44,45	1,6	16,1	10	M16	63,0	21,1	25,0	93,4	22,5	7,0	82,0	32,0
50 ★	69,85	3,2	25,7	12	M24	97,5	32,0	39,2	126,8	35,3	13,0	115,0	47,0

Werkstoff: Legierter Einsatzstahl mit einer Zugfestigkeit im Kern von min. 1200 N / mm². Einsatzgehärtet HRC 60 ± 2 (HV 700 ± 50), Härtetiefe 0,8 mm ± 0,2 mm, brüniert und präzisionsgeschliffen.

Genauigkeit: Kegelwinkel – Toleranzqualität < AT 3 nach DIN 7187 und DIN 2080.

Material: *Alloyed case-hardened steel, tensile core strength of min. 1200 N / mm². Case hardened HRC 60 ± 2 (HV 700 ± 50), hardening depth 0.8 mm ± 0.2 mm, black-finished and precisely grinded.*
Accuracy: *Quality of taper < AT 3 according to DIN 7187 and DIN 2080.*
Matière: Acier de cémentation allié. Résistance à la traction dans le noyau de min 1200 N / mm². Cémentation à HRC 60 ± 2 (HV 700 ± 50), profondeur de cémentation 0,8 mm ± 0,2 mm, bruni et rectifié précisément.

Précision: Qualité du cône < AT 3 selon DIN 7187 et DIN 2080.



Index
Sommaire

4.05	4.06	4.07	4.09
4.10	4.11	4.12	4.13
4.14	4.15	4.16	4.17
4.18			





DIN 6388 (ISO 10897) System OZ

Collet chucks DIN 6391 for collets DIN 6388 (ISO 10897) OZ-system
Mandrins à pinces DIN 6391 pour pinces DIN 6388 (ISO 10897) système OZ



Verwendung:
Zur Aufnahme von Werkzeugen mit Zylinderschaft in Spannzangen.
Application:
For mounting straight-shank tools in collets.
Application:
Pour le serrage d'outils avec queue cylindrique dans des pinces de serrage.

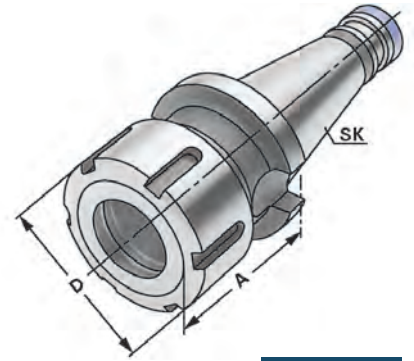

DIN 2080	$\nabla \leq 0,003$	G6,3 15.000 min ⁻¹
----------	---------------------	----------------------------------



Bestell-Nr. Order no. Référence	SK	Spannbereich Capacity Capacité	A	D
301.01.16	SK 30	2 – 16 (OZ 16)	50	43
401.01.16	SK 40	2 – 16 (OZ 16)	55	43
401.01.25	SK 40	2 – 25 (OZ 25)	66	60
401.01.32	SK 40	3 – 32 (OZ 32)	95	72
501.01.25	SK 50	2 – 25 (OZ 25)	71	60
501.01.32	SK 50	3 – 32 (OZ 32)	73	72

Lieferumfang: Mit kugellagerter Spannmutter
Delivery: With ball bearing clamping nut
Livraison: Avec écrou de serrage à roulement à billes



DIN 6499 (ISO 15488) System ER

Collet chucks for collets DIN 6499 (ISO 15488) ER-system
Mandrins à pinces pour pinces DIN 6499 (ISO 15488) système ER



Verwendung:
Zur Aufnahme von Werkzeugen mit
Zylinderschaft in Spannzangen.

Application:
For mounting straight-shank tools in
collets.

Application:
Pour le serrage d'outils avec queue
cylindrique dans des pinces de serrage.

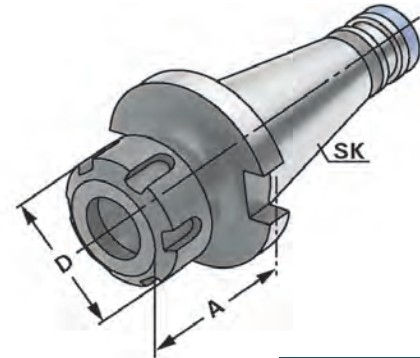

DIN 2080

 $\nabla \leq 0,003$ G6,3
15.000 min⁻¹

14.04

4

Bestell-Nr. Order no. Référence	SK	Spannbereich Capacity Capacité	A	D
301.02.16	SK 30	2 – 16 (ER 25)	50	42
301.02.20	SK 30	2 – 20 (ER 32)	50	50
401.02.16	SK 40	2 – 16 (ER 25)	50	42
401.02.20	SK 40	2 – 20 (ER 32)	50	50
401.02.26	SK 40	3 – 26 (ER 40)	80	63
501.02.20	SK 50	2 – 20 (ER 32)	63	50
501.02.26	SK 50	3 – 26 (ER 40)	63	63

Lieferumfang: Mit gewuchteter Spannmutter
Delivery: With balanced clamping nut
Livraison: Avec écrou de serrage équilibré

Gewuchtete Ausführung

Balanced type
Type équilibré



Bestell-Nr. Order no. Référence	Abmessung Size Dimension
---------------------------------------	--------------------------------

Wuchten auf G 2,5 von vorgewuchteten
Kemmler-Werkzeugen
Balancing at G 2.5 of pre-balanced Kemmler-tools
Équilibrage sur G 2,5 d'outils Kemmler pré-équilibrés

W25 **Ohne Wuchtprotokoll**
Without balancing report
Sans protocole d'équilibrage

W25.2 **Mit Wuchtprotokoll**
With balancing report
Avec protocole d'équilibrage

Wuchten von nicht vorgewuchteten Werkzeugen
Balancing of unbalanced tools
Équilibrage d'outils non-équilibrés

W25.1 **Ohne Wuchtprotokoll**
Without balancing report
Sans protocole d'équilibrage



End mill holders DIN 6359 for end mills DIN 1835-B
 Porte-fraises DIN 6359 pour queues cylindriques DIN 1835-B



Verwendung:
 Zum Spannen von zylindrischen Werkzeugschäften mit seitlicher Spannfläche nach DIN 1835 Form B (Weldon).

Application:
 For mounting straight-shank tools with lateral flat according to DIN 1835 form B (Weldon).

Application:
 Pour le serrage d'outils avec queue cylindrique et avec méplat suivant DIN 1835 forme B (Weldon).

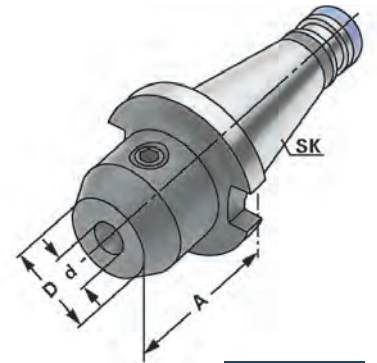

4

DIN 2080

$\nabla \leq 0,003$

G6,3
 15.000 min⁻¹

1.4.04

Bestell-Nr. Order no. Référence	SK	d ^{H4}	A	D
301.04.06	SK 30	6	40	25
301.04.08	SK 30	8	40	28
301.04.10	SK 30	10	40	35
301.04.12	SK 30	12	40	42
301.04.14	SK 30	14	50	44
301.04.16	SK 30	16	50	48
301.04.18	SK 30	18	50	50
301.04.20	SK 30	20	63	52
401.04.06	SK 40	6	50	25
401.04.08	SK 40	8	50	28
401.04.10	SK 40	10	50	35
401.04.12	SK 40	12	50	42
401.04.14	SK 40	14	50	44
401.04.16	SK 40	16	63	48
401.04.18	SK 40	18	63	50
401.04.20	SK 40	20	63	52
401.04.25	SK 40	25	80	65
401.04.32	SK 40	32	80	72
401.04.40	SK 40	40	90	80

Hinweis: Ab d = 25 mit zwei Spannschrauben
Note: From d = 25 on two clamping screws
Observation: A partir de d = 25 avec deux vis de serrage

Lieferumfang: Mit Spannschraube
Delivery: With clamping screw
Livraison: Avec vis de serrage



End mill holders DIN 6359 for end mills DIN 1835-B

Porte-fraises DIN 6359 pour queues cylindriques DIN 1835-B

**Verwendung:**

Zum Spannen von zylindrischen Werkzeugschäften mit seitlicher Spannfläche nach DIN 1835 Form B (Weldon).

Application:

For mounting straight-shank tools with flat according to DIN 1835 form B (Weldon).

Application:

Pour le serrage d'outils avec queue cylindrique et avec méplat suivant DIN 1835 forme B (Weldon).

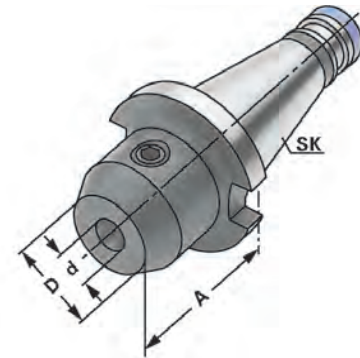

DIN 2080

 $\nabla \leq 0,003$ G6,3
15.000 min⁻¹

14.04

4

Bestell-Nr. Order no. Référence	SK	d ^{H4}	A	D
501.04.06	SK 50	6	63	25
501.04.08	SK 50	8	63	28
501.04.10	SK 50	10	63	35
501.04.12	SK 50	12	63	42
501.04.14	SK 50	14	63	44
501.04.16	SK 50	16	63	48
501.04.18	SK 50	18	63	50
501.04.20	SK 50	20	63	52
501.04.25	SK 50	25	80	65
501.04.32	SK 50	32	80	72
501.04.40	SK 50	40	90	80

Hinweis: Ab d = 25 mit zwei Spannschrauben
Note: From d = 25 on two clamping screws
Observation: A partir de d = 25 avec deux vis de serrage

Lieferumfang: Mit Spannschraube
Delivery: With clamping screw
Livraison: Avec vis de serrage

Gewuchtete Ausführung**Balanced type
Type équilibré**

Bestell-Nr. Order no. Référence	Abmessung Size Dimension
---------------------------------------	--------------------------------

**Wuchten auf G 2,5 von vorgewuchteten
Kemmler-Werkzeugen**

Balancing at G 2.5 of pre-balanced Kemmler-tools
Equilibrage sur G 2,5 d'outils Kemmler pré-équilibrés

W25

**Ohne Wuchtprotokoll
Without balancing report
Sans protocole d'équilibrage**

W25.2

**Mit Wuchtprotokoll
With balancing report
Avec protocole d'équilibrage**

**Wuchten von nicht vorgewuchteten Werkzeugen
Balancing of unbalanced tools
Equilibrage d'outils non-équilibrés**

W25.1

**Ohne Wuchtprotokoll
Without balancing report
Sans protocole d'équilibrage**





Adaptor sleeves for MT with tang DIN 6383
Douilles de réduction pour CM à tenon DIN 6383



Verwendung:
Zur Aufnahme von Werkzeugen mit Morsekegelschaft und Austreiblappen nach DIN 228-1 Form B.

Application:
For mounting tools with Morse taper shank and tang according to DIN 228-1 form B.

Application:
Pour le serrage d'outils avec queue cône Morse et tenon suivant DIN 228-1 forme B.

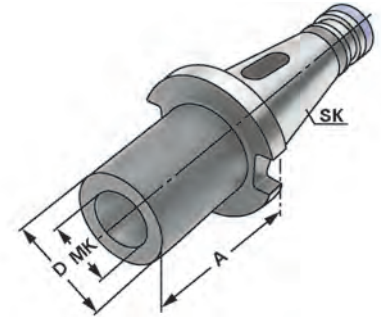

4

DIN 2080

$\nabla \leq 0,005$

G6,3
15.000 min⁻¹

Bestell-Nr. Order no. Référence	SK	MK MT CM	A	D
301.07.01	SK 30	1	50	25
301.07.02	SK 30	2	50	32
301.07.03	SK 30	3	75	40
401.07.01	SK 40	1	50	25
401.07.02	SK 40	2	50	32
401.07.03	SK 40	3	65	40
401.07.04	SK 40	4	95	48
501.07.01	SK 50	1	45	25
501.07.02	SK 50	2	60	32
501.07.03	SK 50	3	65	40
501.07.04	SK 50	4	70	48
501.07.05	SK 50	5	105	63





Adaptor sleeves for MT with drawbar thread DIN 6364
 Douilles de réduction pour CM avec filetage DIN 6364



Verwendung:
 Zum Spannen von Werkzeugen mit Morsekegelschaft und Anzugsgewinde nach DIN 228-1 Form A.

Application:
 For clamping tools with Morse taper shank and thread according to DIN 228-1 form A.

Application:
 Pour le serrage d'outils avec queue cône Morse et filetage suivant DIN 228-1 forme A.

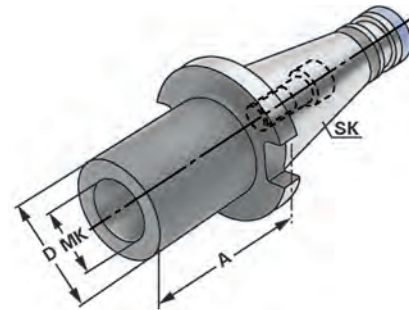

DIN 2080 $\nearrow \leq 0,005$ G6,3
 15.000 min⁻¹

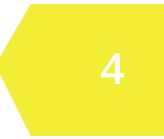

Bestell-Nr. Order no. Référence	SK	MK MT CM	M	A	D
401.08.01	SK 40	1	M6	50	25
401.08.02	SK 40	2	M10	50	32
401.08.03	SK 40	3	M12	65	40
401.08.04	SK 40	4	M16	95	48
401.08.04A*	SK 40	4	M16	110	63
501.08.01	SK 50	1	M6	60	25
501.08.02	SK 50	2	M10	60	32
501.08.03	SK 50	3	M12	65	40
501.08.04	SK 50	4	M16	65	48
501.08.04A*	SK 50	4	M16	80	63
501.08.05	SK 50	5	M20	120	63
501.08.05A*	SK 50	5	M20	138	78

- * Mit Mitnahmeausfräsung nach DIN 2201
- * With drive flats according to DIN 2201
- * Avec des fraises d'entraînement suivant DIN 2201

Lieferumfang: Mit eingebauter Fräseranzugsschraube
Delivery: With built-in tightening bolt
Livraison: Avec vis de serrage montée





Combi shell mill holders DIN 6358
Porte-fraises à double usage DIN 6358



Verwendung:
Zur Aufnahme von Walzen-, Walzenstirnfräsern oder Messerköpfen mit Längs- oder Quernut.

Application:
For mounting milling cutters with transverse or longitudinal groove.

Application:
Pour le serrage de fraises à rainure transversale ou à rainure longitudinale.

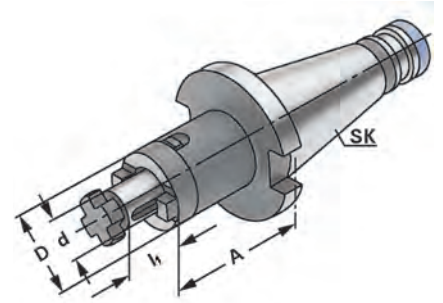

4

DIN 2080

$\nabla \leq 0,005$

G6,3
15.000 min⁻¹

Bestell-Nr. Order no. Référence	SK	d _{H6}	A	l ₁	D
301.10.16	SK 30	16	35	17	32
301.10.22	SK 30	22	35	19	40
301.10.27	SK 30	27	35	21	48
301.10.32	SK 30	32	50	24	58
401.10.16	SK 40	16	52	17	32
401.10.22	SK 40	22	52	19	40
401.10.27	SK 40	27	52	21	48
401.10.32	SK 40	32	52	24	58
401.10.40	SK 40	40	52	27	70
501.10.16	SK 50	16	55	17	32
501.10.22	SK 50	22	55	19	40
501.10.27	SK 50	27	55	21	48
501.10.32	SK 50	32	55	24	58
501.10.40	SK 50	40	55	27	70

Lieferumfang: Mit Fräseranzugsschraube, Mitnehmerring und Passfeder
Delivery: With tightening bolt, driving ring and feather key
Livraison: Avec vis de blocage, bague d'entraînement et clavette

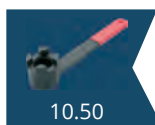

10.50



10.48



10.51



10.51



mit vergrößerter Anlagefläche

Shell mill holders DIN 6357 with enlarged contact face
 Porte-fraises à trou lisse DIN 6357 avec face de contact élargie



Verwendung:
 Zur Aufnahme von Messerköpfen und Fräsern mit Quernut.
Application:
 For mounting milling cutters with transversal groove.
Application:
 Pour le serrage de fraises à rainure transversale.

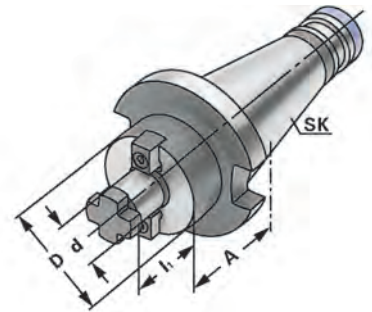

DIN 2080 $\nabla \leq 0,005$ G6,3 15.000 min⁻¹

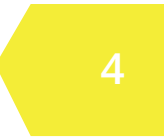

Bestell-Nr. Order no. Référence	SK	d _{h6}	l ₁	A	D
401.11.16	SK 40	16	17	30	38
401.11.22	SK 40	22	19	30	48
401.11.27	SK 40	27	21	30	58
401.11.32	SK 40	32	24	30	78
401.11.40	SK 40	40	27	30	88
501.11.22	SK 50	22	19	35	48
501.11.27	SK 50	27	21	35	58
501.11.32	SK 50	32	24	40	78
501.11.40	SK 50	40	27	33	88
501.11.60	SK 50	60	40	55	129

d = 40/d = 60: Für große Planfräser mit vier zusätzlichen Gewindebohrungen nach DIN 2079.
 For large diameter face mill cutters with four additional threaded holes according to DIN 2079.
 Pour fraises à surfacer à grands diamètres avec quatre trous taraudés additionnels suivant DIN 2079.

Lieferumfang: Mit Mitnehmersteinen, Kreuzschraube und Zylinderkopfschraube nach DIN 912.
 Bei d = 60 nur mit vier Befestigungsschrauben nach DIN 912.

Delivery: With drivers, cross head retaining screw and cylinder head retaining screw DIN 912.
 For d = 60 only with four fixation screws according to DIN 912.

Livraison: Avec tenons, une vis cruciforme et une vis à tête cylindrique suivant DIN 912.
 Pour d = 60 seulement avec quatre vis de fixation suivant DIN 912.





Drill chuck adaptors DIN 238
Arbres pour mandrins de perçage DIN 238



Verwendung:
Zur Aufnahme von Bohrfuttern.
Application:
For mounting drill chucks.
Application:
Pour le serrage de mandrins de perçage.

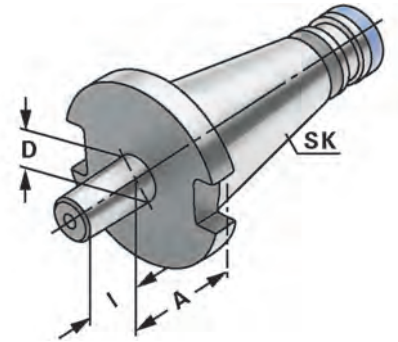

4

DIN 2080 $\nabla \leq 0,005$ G6,3
15.000 min⁻¹

Bestell-Nr. Order no. Référence	SK	D	A	I
301.14.12	SK 30	B12	15	18,5
301.14.16	SK 30	B16	17	24
401.14.12	SK 40	B12	15	18,5
401.14.16	SK 40	B16	17	24
401.14.18	SK 40	B18	17	32
501.14.16	SK 50	B16	20	24
501.14.18	SK 50	B18	20	32



CNC-Drill chucks for clockwise and counter clockwise rotation
Mandrins de perçage CNC pour rotation gauche-droite



Verwendung:
Zur Aufnahme von Werkzeugen mit Zylinderschaft.

Application:
For mounting tools with straight shanks.

Application:
Pour le serrage d'outils avec queue cylindrique.

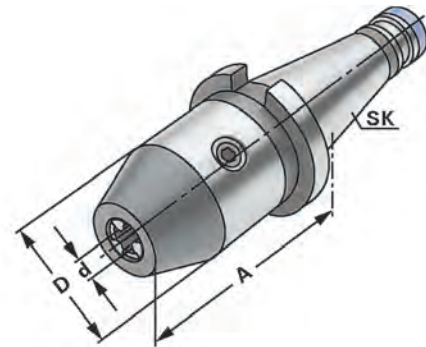

DIN 2080

 $\nearrow \leq 0,030$

 G6,3
15.000 min⁻¹
 14.04

4

Bestell-Nr. Order no. Référence	SK	Spannbereich Capacity Capacité	A	D
301.15.08	SK 30	0 – 8	60	36
301.15.13	SK 30	1,0 – 13	90	50
301.15.16	SK 30	2,5 – 16	95	50
401.15.08	SK 40	0 – 8	63	36
401.15.13	SK 40	1,0 – 13	83	50
401.15.16	SK 40	2,5 – 16	88	50
501.15.13	SK 50	1,0 – 13	85	50
501.15.16	SK 50	2,5 – 16	90	50

Hinweis: Hohe Präzision und Rundlaufgenauigkeit von $\leq 0,03$ mm. Sichere Spannung des Werkzeuges durch mechanische Spannkraftverstärkung. Kein selbständiges Lösen der Spannung während der Bearbeitung bei Links- oder Rechtslauf, sowie bei Spindelstop. Spannen und Lösen mit Sechskantschlüssel.

Note: High precision and accurate concentricity of ≤ 0.03 mm. Secure gripping of the tool through mechanical amplification of the clamping force. No automatic slacking of the clamping force while machining with either clockwise or counter clockwise rotation or on spindle stop. Clamping and releasing effected by means of an Allen wrench.

Observation: Précision élevée et exactitude de circularité de $\leq 0,03$ mm. Serrage sûr de l'outil grâce à l'amplification de la force de serrage. Pas de desserrage intempestif en cours d'usinage lors de la rotation la gauche ou la droite, de même qu'en cas d'arrêt de la broche. Serrage et desserrage en utilisant un clé sur à fourche.

Lieferumfang: Mit Spannschlüssel
Delivery: With wrench
Livraison: Avec clé de serrage



10.23



Adaptor sleeves for ISO-toolholders
Douilles de réduction pour porte-outils ISO/SA



Verwendung:
Zur Aufnahme von Steilkegeln nach DIN 69871, JIS B 6339 und DIN 2080.
Application:
For holding tapers according to DIN 69871, JIS B 6339 and DIN 2080.
Application:
Pour le serrage de porte-outils suivant DIN 69871, JIS B 6339 et DIN 2080.

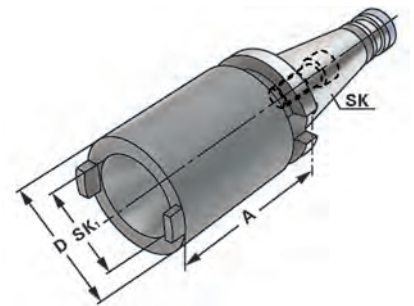

DIN 2080 $\nabla \leq 0,005$ G6,3
15.000 min⁻¹

Bestell-Nr. Order no. Référence	SK	SK ₁	A	D
401.09.30	SK 40	SK 30	50	50
401.09.40	SK 40	SK 40	100	63
501.09.40	SK 50	SK 40	50	70
501.09.50	SK 50	SK 50	125	97

Hinweis: Lieferung erfolgt mit eingebauter Schraube für Werkzeuge mit DIN 2080. Schraube für DIN 69871 Werkzeuge beiliegend.
Note: Delivered with a built-in screw for DIN 2080 tools. Additional screw for DIN 69871 tools included.
Observation: Livraison avec un vis incorporée pour outils DIN 2080. Vis pour cônes DIN 69871 incluse.



Boring bar blanks
Barres d'alésage



Verwendung:
Zur Herstellung von Sonderwerkzeugen.
Application:
For the manufacturing of special tools.
Application:
Pour la fabrication d'outils spéciaux.

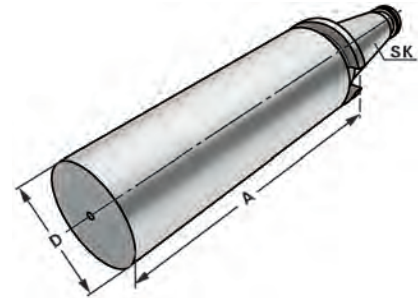

DIN 2080

4

Bestell-Nr.
Order no.
Référence

SK

A

D

401.17.63

SK 40

250

63

501.17.97

SK 50

315

97

Ausführung: Steilkegel und Bund gehärtet und geschliffen. Schaft weich zur weiteren Bearbeitung.
Version: *Cone and flange hardened and grinded. Soft body for later processing.*
Version: Cône et collerette durcis et rectifiés. Corps doux pour un usinage ultérieur.



auf Druck und Zug

Quick change tapping chucks with length compensation on compression and expansion
Mandrins de taraudage à changement rapide avec compensation longitudinale à la compression et traction



Verwendung:
Zur Aufnahme von Schnellwechsel-Ein-sätzen für Gewindebohrer.
Application:
For the chucking of quick change adaptors for taps.
Application:
Pour le serrage d'adapteurs porte-tarauts à changement rapide.

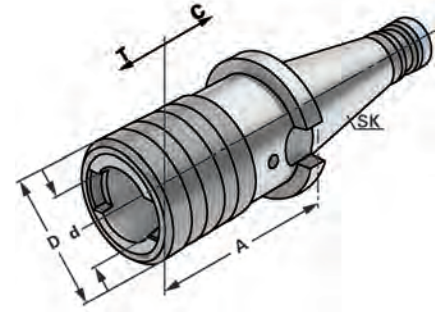

DIN 2080



Bestell-Nr. Order no. Référence	SK	Spannbereich Capacity Capacité	Größe Size Taille	A	D	d	C	T
301.16.12	SK 30	M3 - M14	1	55	38	19	7	7
301.16.20	SK 30	M5 - M22	2	86	54	31	12	12
401.16.12	SK 40	M3 - M14	1	55	38	19	7	7
401.16.20	SK 40	M5 - M22	2	86	54	31	12	12
401.16.36	SK 40	M14 - M36	3	132	78	48	17,5	17,5
501.16.12	SK 50	M3 - M14	1	62	38	19	7	7
501.16.20	SK 50	M5 - M22	2	90	54	31	12	12
501.16.36	SK 50	M14 - M36	3	117	78	48	17,5	17,5



Test arbors
Mandrins de contrôle



Verwendung:
Zur Abnahme von Werkzeugmaschinen gemäß ISO-Empfehlung R230 oder zur Überprüfung der Werkzeugspindel.

Application:
For the inspection of machine tools according to ISO recommendation R230 or for testing the tool spindle.

Application:
Pour l'inspection de machine-outils suite à la recommandation ISO R230 ou pour la vérification de la broche.

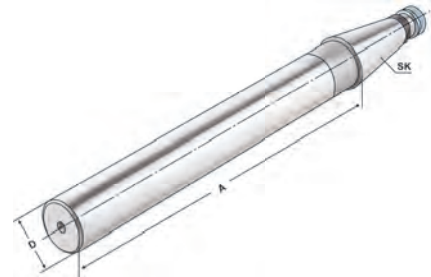

DIN 2080

Bestell-Nr. Order no. Référence	SK	A	D	Toleranz Tolerance Tolérance	max. Rundlaufabweichung max. concentricity deviation Faux-rond max.
401.18.40	SK 40	300	40	0,003	0,003
501.18.50	SK 50	300	50	0,003	0,003

Lieferumfang: Auslieferung mit Prüfprotokoll
Delivery: *Delivery with test certificate*
Livraison: Livraison avec rapport d'essais

4

Holzkasten für Kontrolldorne

Wooden box for test arbors
Coffret en bois pour mandrins de contrôle



Verwendung:
Zur Aufbewahrung von Kontrolldornen.

Application:
For the storage of test arbors.

Application:
Pour la conservation de mandrins de contrôle.



Bestell-Nr. Order no. Référence	Abmessung Size Dimension	für Kegelgrößen for cones pour cônes
701.18	460 × 130 × 115	BT 30 / 40 / 50

*WERKZEUGAUFNAHMEN
DIN 69893 / ISO 12164 (HSK)*

*TOOLHOLDERS
DIN 69893 / ISO 12164 (HSK)*

*PORTE-OUTILS
DIN 69893 / ISO 12164 (HSK)*

DIN 69893 HSK

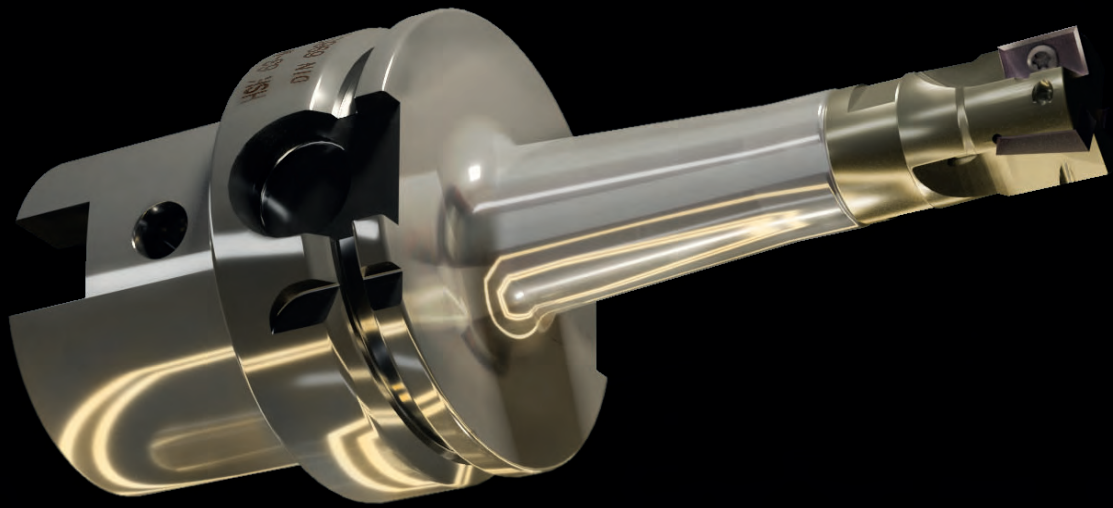

Vorgewuchtet
 Pre-balanced
 Pré-équilibré

G 6,3 15.000 min⁻¹

G 2,5 Feinwuchten gegen Aufpreis
 G 2.5 Fine balancing at extra charge
 G 2,5 Equilibrage fin contre un supplément

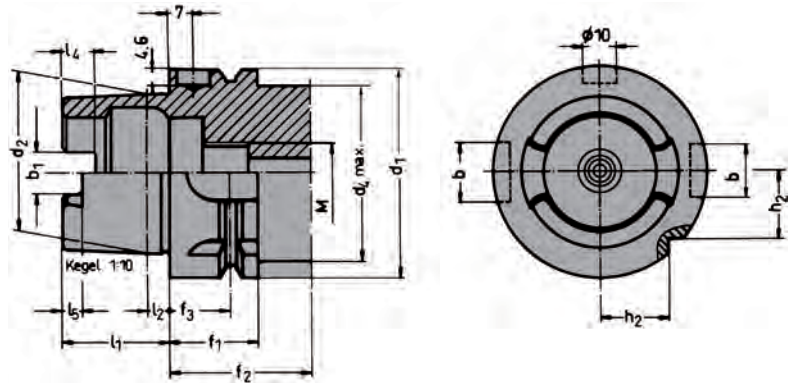

d ₁	d ₂	d ₄	l ₁	l ₂	l ₄	l ₅	M	f ₁	f ₂	f ₃	b ₁	b ₂	b ₃
32	24	26	16	3,2	5,0	3,0	M10 × 1	20	35	16	7,05	7	9
40	30	34	20	4,0	6,0	3,5	M12 × 1	20	35	16	8,05	9	11
50	38	42	25	5,0	7,5	4,5	M16 × 1	26	42	18	10,54	12	14
63	48	53	32	6,3	10,0	6,0	M18 × 1	26	42	18	12,54	16	18
80	60	67	40	8,0	12,0	8,0	M20 × 1,5	26	42	18	16,04	18	20
100	75	85	50	10,0	15,0	10,0	M24 × 1,5	29	45	20	20,02	22	20

Werkstoff: Legierter Einsatzstahl mit einer Zugfestigkeit im Kern von min. 800 N / mm². Einsatzgehärtet HRC 60 ± 2 (HV 700 ± 50), Härtetiefe 0,8 mm ± 0,2 mm, brüniert und präzisionsgeschliffen.

Material: Alloyed case-hardened steel, tensile core strength of min. 800 N / mm². Case hardened HRC 60 ± 2 (HV 700 ± 50), hardening depth 0.8 mm ± 0.2 mm, black-finished and precisely grinded.

Matière: Acier de cémentation allié. Résistance à la traction dans le noyau de min 800 N / mm². Cémentation à HRC 60 ± 2 (HV 700 ± 50), profondeur de cémentation 0,8 mm ± 0,2 mm, bruni et rectifié précisément.



Index
Sommaire

5.05	5.06	5.07	5.09
5.10	5.11	5.17	5.18
5.19	5.21	5.22	5.23
5.24	5.25	5.26	5.27
5.28	5.29	5.33	5.42
5.43	5.44	5.45	5.46
5.47	5.63	5.77	
HSK-C	HSK-E	HSK-F	





Verwendung:

Zur Aufnahme von Werkzeugen mit Zylinderschaft in Spannzangen.

Application:

For mounting straight-shank tools in collets.

Application:

Pour le serrage d'outils avec queue cylindrique dans des pinces de serrage.

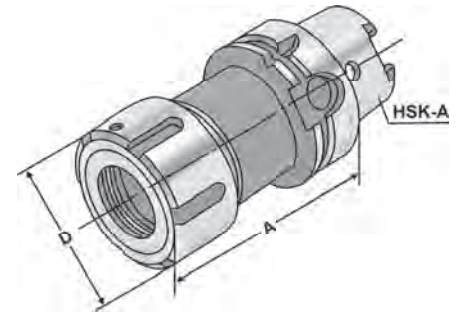

ISO 12164-1
(DIN 69893-1)

HSK - A

$\nabla \leq 0,003$

G6,3
15.000 min⁻¹



5

Bestell-Nr. Order no. Référence	HSK	Spannbereich Capacity Capacité	A	D
A50.01.16	HSK-A 50	2 - 16 (OZ 16)	90	43
A50.01.25	HSK-A 50	2 - 25 (OZ 25)	110	60
A63.01.16	HSK-A 63	2 - 16 (OZ 16)	100	43
A63.01.25	HSK-A 63	2 - 25 (OZ 25)	100	60
A63.01.32	HSK-A 63	3 - 32 (OZ 32)	120	72
A100.01.16	HSK-A 100	2 - 16 (OZ 16)	110	43
A100.01.25	HSK-A 100	2 - 25 (OZ 25)	120	60
A100.01.32	HSK-A 100	3 - 32 (OZ 32)	130	72

Lieferumfang: Mit kugellagerter Spannmutter
Delivery: With ball bearing clamping nut
Livraison: Avec écrou de serrage à roulement à billes





Collet chucks for collets KPS-system
Mandrins à pinces pour pinces système KPS



Verwendung:
Zur Aufnahme von Werkzeugen mit Zylinder-
schaft in Spannzangen.
Für Anwendungen im HSC-Bereich und für
hochpräzise Bearbeitungsergebnisse.

Application:
*For mounting straight-shank tools in collets.
To use for high speed cutting and high
precision milling.*

Application:
Pour le serrage d'outils avec queue cylindrique
dans des pinces de serrage.
Pour l'usage dans le coupage à grande vitesse
et dans l'usinage à grande précision.

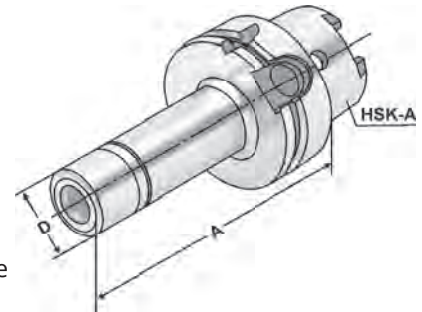

ISO 12164-1
(DIN 69893-1)

HSK - A

$\nabla \leq 0,003$

G2,5
30.000 min⁻¹



Bestell-Nr. Order no. Référence	HSK	Spannbereich Capacity Capacité	A	D
A63.03.10	HSK-A 63	1 – 10 (KPS 10)	100	27,5
A63.03.10.2	HSK-A 63	1 – 10 (KPS 10)	160	27,5
A63.03.16	HSK-A 63	4 – 16 (KPS 16)	120	40,0
A63.03.16.2	HSK-A 63	4 – 16 (KPS 16)	160	40,0

5

Lieferumfang: Mit gewuchteter Spannmutter
Delivery: With balanced clamping nut
Livraison: Avec écrou de serrage équilibré

Gewuchtete Ausführung



Balanced type
Type équilibré

Bestell-Nr. Order no. Référence	Abmessung Size Dimension
---------------------------------------	--------------------------------

**Wuchten auf G 2,5 von vorgewuchteten
Kemmler-Werkzeugen**

Balancing at G 2.5 of pre-balanced Kemmler-tools
Equilibrage sur G 2,5 d'outils Kemmler pré-équilibrés

W25 **Ohne Wuchtprotokoll**
Without balancing report
Sans protocole d'équilibrage

W25.2 **Mit Wuchtprotokoll**
With balancing report
Avec protocole d'équilibrage

Wuchten von nicht vorgewuchteten Werkzeugen
Balancing of unbalanced tools
Equilibrage d'outils non-équilibrés

W25.1 **Ohne Wuchtprotokoll**
Without balancing report
Sans protocole d'équilibrage





Verwendung:

Zur Aufnahme von Werkzeugen mit Zylinderschaft in Spannzangen.

Application:

For mounting straight-shank tools in collets.

Application:

Pour le serrage d'outils avec queue cylindrique dans des pinces de serrage.

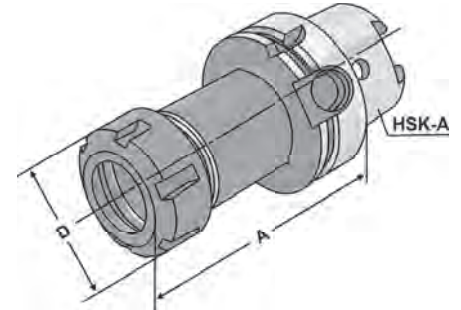

ISO 12164-1
(DIN 69893-1)

HSK - A

$\nabla \leq 0,003$

G6,3
15.000 min⁻¹



5

Bestell-Nr. Order no. Référence	HSK	Spannbereich Capacity Capacité	A	D
A32.02.10	HSK-A 32	1 – 10 (ER 16)	80	32
A32.02.20	HSK-A 32	2 – 20 (ER 32)	85	50
A40.02.10	HSK-A 40	1 – 10 (ER 16)	80	32
A40.02.16	HSK-A 40	2 – 16 (ER 25)	80	42
A40.02.20	HSK-A 40	2 – 20 (ER 32)	80	50
A50.02.10	HSK-A 50	1 – 10 (ER 16)	100	32
A50.02.16	HSK-A 50	2 – 16 (ER 25)	80	42
A50.02.20	HSK-A 50	2 – 20 (ER 32)	100	50

Lieferumfang: Mit gewuchteter Spannmutter

Delivery: With balanced clamping nut

Livraison: Avec écrou de serrage équilibré





Collet chucks for collets DIN 6499 (ISO 15488) ER-system

DIN 69893 (HSK-A)

Mandrins à pinces pour pinces DIN 6499 (ISO 15488) système ER

**Verwendung:**

Zur Aufnahme von Werkzeugen mit Zylinderschaft in Spannzangen.

Application:

For mounting straight-shank tools in collets.

Application:

Pour le serrage d'outils avec queue cylindrique dans des pinces de serrage.

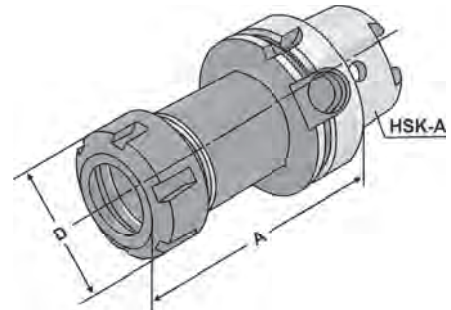
ISO 12164-1
(DIN 69893-1)

HSK - A

 $\uparrow \leq 0,003$ G6,3
15.000 min⁻¹

14.04

Bestell-Nr. Order no. Référence	HSK	Spannbereich Capacity Capacité	A	D
A63.02.10.0	HSK-A 63	1 – 10 (ER 16)	75	32
A63.02.13.0	HSK-A 63	2 – 13 (ER 20)	75	35
A63.02.16.0	HSK-A 63	2 – 16 (ER 25)	75	42
A63.02.20.0	HSK-A 63	2 – 20 (ER 32)	75	50
A63.02.26.0	HSK-A 63	3 – 26 (ER 40)	85	63
A63.02.10	HSK-A 63	1 – 10 (ER 16)	100	32
A63.02.13	HSK-A 63	2 – 16 (ER 20)	100	35
A63.02.16	HSK-A 63	2 – 16 (ER 25)	100	42
A63.02.20	HSK-A 63	2 – 20 (ER 32)	100	50
A63.02.26	HSK-A 63	3 – 26 (ER 40)	120	63
A63.02.10.1	HSK-A 63	1 – 10 (ER 16)	160	32
A63.02.13.1	HSK-A 63	2 – 13 (ER 20)	160	35
A63.02.16.1	HSK-A 63	2 – 16 (ER 25)	160	42
A63.02.20.1	HSK-A 63	2 – 20 (ER 32)	160	50
A63.02.26.1	HSK-A 63	3 – 26 (ER 40)	160	63
A63.02.10.3	HSK-A 63	1 – 10 (ER 16)	200	32
A63.02.13.3	HSK-A 63	2 – 13 (ER 20)	200	35
A63.02.16.3	HSK-A 63	2 – 16 (ER 25)	200	42
A63.02.20.3	HSK-A 63	2 – 20 (ER 32)	200	50
A63.02.26.3	HSK-A 63	3 – 26 (ER 40)	200	63
A100.02.10	HSK-A 100	1 – 10 (ER 16)	100	32
A100.02.16	HSK-A 100	2 – 16 (ER 25)	100	42
A100.02.20	HSK-A 100	2 – 20 (ER 32)	100	50
A100.02.26	HSK-A 100	3 – 26 (ER 40)	120	63
A100.02.10.2	HSK-A 100	1 – 10 (ER 16)	160	32
A100.02.16.2	HSK-A 100	2 – 16 (ER 25)	160	42
A100.02.20.2	HSK-A 100	2 – 20 (ER 32)	160	50
A100.02.26.2	HSK-A 100	3 – 26 (ER 40)	160	63

Lieferumfang: Mit gewichteter Spannmutter

Delivery: With balanced clamping nut

Livraison: Avec écrou de serrage équilibré





Spannfutter für Spannzangen DIN 6499 (ISO 15488) System ER - MiniISO 12164 (HSK-A)

Collet chucks for collets DIN 6499 (ISO 15488) ER-system - Mini
Mandrins à pinces pour pinces DIN 6499 (ISO 15488) système ER - Mini

DIN 69893 (HSK-A)



Verwendung:
Zur Aufnahme von Werkzeugen mit Zylinderschaft in Spannzangen.
Application:
For mounting straight-shank tools in collets.
Application:
Pour le serrage d'outils avec queue cylindrique dans des pinces de serrage.

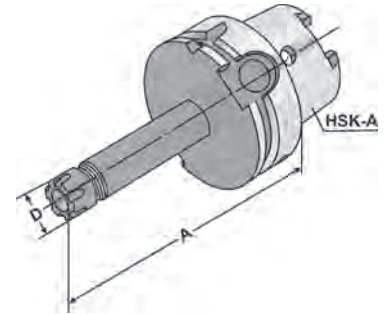

ISO 12164-1
(DIN 69893-1)

HSK - A

$\nabla \leq 0,003$

G2.5
30.000 min⁻¹



5

Bestell-Nr. Order no. Référence	HSK	Spannbereich Capacity Capacité	A	D
A32.02.07.M	HSK-A 32	1 – 7 (ER 11) Mini	50	16
A32.02.10.M	HSK-A 32	1 – 10 (ER 16) Mini	50	22
A32.02.16.M	HSK-A 32	2 – 16 (ER 25) Mini	80	35
A40.02.07.M	HSK-A 40	1 – 7 (ER 11) Mini	40	16
A40.02.10.M	HSK-A 40	1 – 10 (ER 16) Mini	80	22
A50.02.07.M	HSK-A 50	1 – 7 (ER 11) Mini	60	16
A50.02.10.M	HSK-A 50	1 – 10 (ER 16) Mini	60	22
A63.02.07.1	HSK-A 63	1 – 7 (ER 11)	100	16
A63.02.07.2	HSK-A 63	1 – 7 (ER 11)	160	16
A63.02.07.10.1	HSK-A 63	1 – 10 (ER 16)	100	22
A63.02.07.10.2	HSK-A 63	1 – 10 (ER 16)	160	22

Gewuchtete Ausführung



Balanced type
Type équilibré

Bestell-Nr. Order no. Référence	Abmessung Size Dimension
---------------------------------------	--------------------------------

Wuchten auf G 2,5 von vorgewuchteten
Kemmler-Werkzeugen

Balancing at G 2.5 of pre-balanced Kemmler-tools
Équilibrage sur G 2,5 d'outils Kemmler pré-équilibrés
W25

Ohne Wuchtprotokoll
Without balancing report
Sans protocole d'équilibrage

W25.2

Mit Wuchtprotokoll
With balancing report
Avec protocole d'équilibrage

Wuchten von nicht vorgewuchteten Werkzeugen
Balancing of unbalanced tools
Équilibrage d'outils non-équilibrés

W25.1

Ohne Wuchtprotokoll
Without balancing report
Sans protocole d'équilibrage





Verwendung:
Zur Aufnahme von Werkzeugen mit Zylinderschaft nach DIN 1835 Form A+B+E und DIN 6535 Form HA+HB+HE.

Application:
For mounting straight-shank tools acc. DIN 1835 form A+B+E and DIN 6535 form HA+HB+HE.

Application:
Pour le serrage d'outils avec queue cylindrique suivant DIN 1835 forme A+B+E et DIN 6535 forme HA+HB+HE.

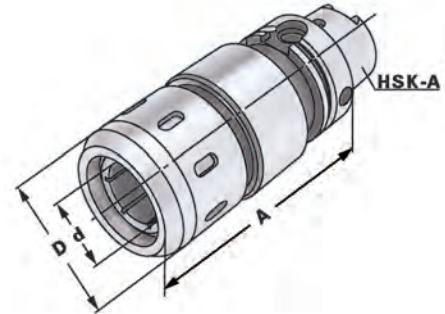

ISO 12164-1
(DIN 69893-1)

HSK - A

$\nabla \leq 0,003$

G6.3
15.000 min⁻¹



Bestell-Nr. Order no. Référence	HSK	Spannbereich Capacity Capacité	A	D	d
A63.64.20	HSK-A 63	20 (HKS 20)	95	53	20
A63.64.25	HSK-A 63	25 (HKS 25)	100	63	25
A63.64.32	HSK-A 63	32 (HKS 32)	110	68	32
A100.64.20	HSK-A 100	20 (HKS 20)	105	53	20
A100.64.25	HSK-A 100	25 (HKS 25)	105	63	25
A100.64.32	HSK-A 100	32 (HKS 32)	105	68	32



**Verwendung:**

Zum Spannen von zylindrischen Werkzeugschäften mit seitlicher Spannfläche nach DIN 1835 Form B (Weldon).

Application:

For mounting straight-shank tools with lateral flat according to DIN 1835 form B (Weldon).

Application:

Pour le serrage d'outils avec queue cylindrique et avec méplat suivant DIN 1835 forme B (Weldon).

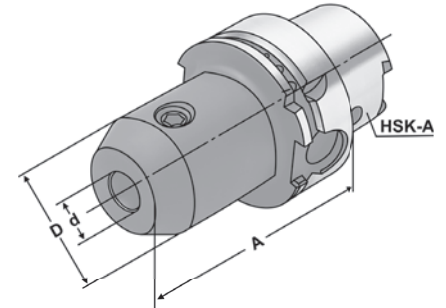
ISO 12164-1
(DIN 69893-1)

HSK - A

 $\nabla \leq 0,003$ G6,3
15.000 min⁻¹

5

Bestell-Nr. Order no. Référence	HSK	d ^{H4}	A	D
A32.04.06	HSK-A 32	6	60	25
A32.04.08	HSK-A 32	8	60	28
A32.04.10	HSK-A 32	10	65	35
A32.04.12	HSK-A 32	12	70	42
A32.04.14	HSK-A 32	14	75	44
A32.04.16	HSK-A 32	16	75	48
A32.04.20	HSK-A 32	20	90	50
A40.04.06	HSK-A 40	6	60	25
A40.04.08	HSK-A 40	8	60	28
A40.04.10	HSK-A 40	10	60	35
A40.04.12	HSK-A 40	12	70	42
A40.04.14	HSK-A 40	14	75	44
A40.04.16	HSK-A 40	16	75	40
A40.04.18	HSK-A 40	18	85	40
A40.04.20	HSK-A 40	20	85	40
A40.04.25	HSK-A 40	25	100	45
A40.04.32	HSK-A 40	32	105	60
A50.04.06	HSK-A 50	6	65	25
A50.04.08	HSK-A 50	8	65	28
A50.04.10	HSK-A 50	10	65	35
A50.04.12	HSK-A 50	12	80	42
A50.04.14	HSK-A 50	14	80	44
A50.04.16	HSK-A 50	16	80	48
A50.04.18	HSK-A 50	18	80	50
A50.04.20	HSK-A 50	20	80	52
A50.04.25	HSK-A 50	25	110	60
A50.04.32	HSK-A 50	32	110	60

Hinweis: Ab d = 25 mit zwei Spannschrauben
Note: From d = 25 on two clamping screws
Observation: A partir de d = 25 avec deux vis de serrage

Lieferumfang: Mit Spannschraube
Delivery: With clamping screw
Livraison: Avec vis de serrage



End mill holders DIN 6359 for end mills DIN 1835-B

DIN 69893 (HSK-A)

Porte-fraises DIN 6359 pour queues cylindriques DIN 1835-B

**Verwendung:**

Zum Spannen von zylindrischen Werkzeugschäften mit seitlicher Spannfläche nach DIN 1835 Form B (Weldon).

Application:

For mounting straight-shank tools with lateral flat according to DIN 1835 form B (Weldon).

Application:

Pour le serrage d'outils avec queue cylindrique et avec méplat suivant DIN 1835 forme B (Weldon).

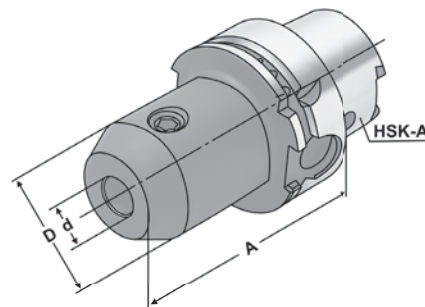
ISO 12164-1
(DIN 69893-1)

HSK - A

 $\lambda \leq 0,003$ G6,3
15.000 min⁻¹

14.04

Bestell-Nr. Order no. Référence	HSK	d ^{H4}	A	D
A63.04.06	HSK-A 63	6	65	25
A63.04.08	HSK-A 63	8	65	28
A63.04.10	HSK-A 63	10	65	35
A63.04.12	HSK-A 63	12	80	42
A63.04.14	HSK-A 63	14	80	44
A63.04.16	HSK-A 63	16	80	48
A63.04.18	HSK-A 63	18	80	50
A63.04.20	HSK-A 63	20	80	52
A63.04.25	HSK-A 63	25	110	65
A63.04.32	HSK-A 63	32	110	72
A63.04.40	HSK-A 63	40	125	80
A63.04.06.1	HSK-A 63	6	100	25
A63.04.08.1	HSK-A 63	8	100	28
A63.04.10.1	HSK-A 63	10	100	35
A63.04.12.1	HSK-A 63	12	100	35
A63.04.14.1	HSK-A 63	14	100	44
A63.04.16.1	HSK-A 63	16	100	48
A63.04.18.1	HSK-A 63	18	100	50
A63.04.20.1	HSK-A 63	20	100	52
A63.04.06.2	HSK-A 63	6	160	25
A63.04.08.2	HSK-A 63	8	160	28
A63.04.10.2	HSK-A 63	10	160	35
A63.04.12.2	HSK-A 63	12	160	35
A63.04.14.2	HSK-A 63	14	160	44
A63.04.16.2	HSK-A 63	16	160	48
A63.04.18.2	HSK-A 63	18	160	50
A63.04.20.2	HSK-A 63	20	160	52

Hinweis:

Ab d = 25 mit zwei Spannschrauben

Note:

From d = 25 on two clamping screws

Observation:

A partir de d = 25 avec deux vis de serrage

Lieferumfang:

Mit Spannschraube

Delivery:

With clamping screw

Livraison:

Avec vis de serrage



**Verwendung:**

Zum Spannen von zylindrischen Werkzeugschäften mit seitlicher Spannfläche nach DIN 1835 Form B (Weldon).

Application:

For mounting straight-shank tools with lateral flat according to DIN 1835 form B (Weldon).

Application:

Pour le serrage d'outils avec queue cylindrique et avec méplat suivant DIN 1835 forme B (Weldon).

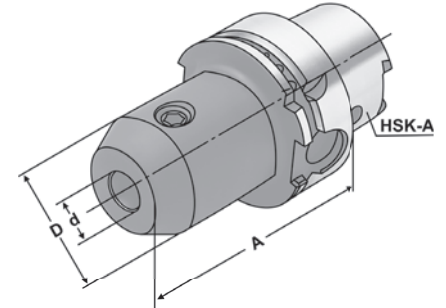
ISO 12164-1
(DIN 69893-1)

HSK - A

 $\nabla \leq 0,003$ G6,3
15.000 min⁻¹

5

Bestell-Nr. Order no. Référence	HSK	d ^{H4}	A	D
A80.04.06	HSK-A 80	6	80	25
A80.04.08	HSK-A 80	8	80	28
A80.04.10	HSK-A 80	10	80	35
A80.04.12	HSK-A 80	12	80	42
A80.04.14	HSK-A 80	14	80	44
A80.04.16	HSK-A 80	16	100	48
A80.04.18	HSK-A 80	18	100	50
A80.04.20	HSK-A 80	20	100	52
A80.04.25	HSK-A 80	25	100	65
A80.04.32	HSK-A 80	32	110	72
A80.04.40	HSK-A 80	40	120	80
A100.04.06	HSK-A 100	6	80	25
A100.04.08	HSK-A 100	8	80	28
A100.04.10	HSK-A 100	10	80	35
A100.04.12	HSK-A 100	12	80	42
A100.04.14	HSK-A 100	14	80	44
A100.04.16	HSK-A 100	16	100	48
A100.04.18	HSK-A 100	18	100	50
A100.04.20	HSK-A 100	20	100	52
A100.04.25	HSK-A 100	25	100	65
A100.04.32	HSK-A 100	32	100	72
A100.04.40	HSK-A 100	40	105	80
A100.04.06.2	HSK-A 100	6	160	25
A100.04.08.2	HSK-A 100	8	160	28
A100.04.10.2	HSK-A 100	10	160	35
A100.04.12.2	HSK-A 100	12	160	35
A100.04.14.2	HSK-A 100	14	160	44
A100.04.16.2	HSK-A 100	16	160	48
A100.04.18.2	HSK-A 100	18	160	50
A100.04.20.2	HSK-A 100	20	160	52
A100.04.25.2	HSK-A 100	25	160	65
A100.04.32.2	HSK-A 100	32	160	72
A100.04.40.2	HSK-A 100	40	160	80

Hinweis:**Note:****Observation:**

Ab d = 25 mit zwei Spannschrauben

From d = 25 on two clamping screws

A partir de d = 25 avec deux vis de serrage

Lieferumfang:**Delivery:****Livraison:**

Mit Spannschraube

With clamping screw

Avec vis de serrage

End mill holders DIN 6359 with coolant channels for end mills DIN 1835-B

Porte-fraises DIN 6359 avec canaux d'arrosage pour queues cylindriques DIN 1835-B

**Verwendung:**

Zum Spannen von zylindrischen Werkzeugschäften mit seitlicher Spannfläche nach DIN 1835 Form B (Weldon). Mit Kühlkanälen für optimale Kühlung der Werkzeugschneide.

Application:

For mounting straight-shank tools with lateral flat according to DIN 1835 form B (Weldon). With coolant channels for optimal coolant at the cutting edge.

Application:

Pour le serrage d'outils avec queue cylindrique et avec méplat suivant DIN 1835 forme B (Weldon). Avec canaux d'arrosage pour un refroidissement optimal aux lames.

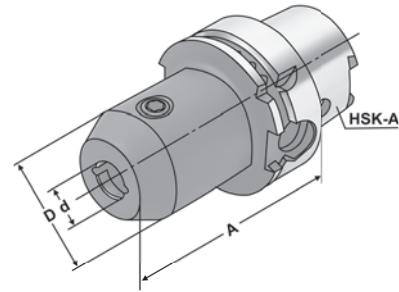
ISO 12164-1
(DIN 69893-1)

HSK - A

 $\lambda \leq 0,003$ G6,3
15.000 min⁻¹

14.04

Bestell-Nr. Order no. Référence	HSK	d ^{H4}	A	D
A63.04.06.K	HSK-A 63	6	65	25
A63.04.08.K	HSK-A 63	8	65	28
A63.04.10.K	HSK-A 63	10	65	35
A63.04.12.K	HSK-A 63	12	80	42
A63.04.14.K	HSK-A 63	14	80	44
A63.04.16.K	HSK-A 63	16	80	48
A63.04.18.K	HSK-A 63	18	80	50
A63.04.20.K	HSK-A 63	20	80	52
A63.04.25.K	HSK-A 63	25	110	65
A63.04.32.K	HSK-A 63	32	110	72
A63.04.40.K	HSK-A 63	40	125	80
A63.04.06.1.K	HSK-A 63	6	100	25
A63.04.08.1.K	HSK-A 63	8	100	28
A63.04.10.1.K	HSK-A 63	10	100	35
A63.04.12.1.K	HSK-A 63	12	100	42
A63.04.14.1.K	HSK-A 63	14	100	44
A63.04.16.1.K	HSK-A 63	16	100	48
A63.04.18.1.K	HSK-A 63	18	100	50
A63.04.20.1.K	HSK-A 63	20	100	52
A100.04.06.K	HSK-A 100	6	80	25
A100.04.08.K	HSK-A 100	8	80	28
A100.04.10.K	HSK-A 100	10	80	35
A100.04.12.K	HSK-A 100	12	80	42
A100.04.14.K	HSK-A 100	14	80	44
A100.04.16.K	HSK-A 100	16	100	48
A100.04.18.K	HSK-A 100	18	100	50
A100.04.20.K	HSK-A 100	20	100	52
A100.04.25.K	HSK-A 100	25	100	65
A100.04.32.K	HSK-A 100	32	100	72
A100.04.40.K	HSK-A 100	40	105	80

Hinweis:

d = 6 bis 18 mit zwei Kühlkanälen

d = 20 bis 40 mit vier Kühlkanälen

Für Werkzeuge mit innerer Kühlmittelzufuhr muss ein O-Ring eingesetzt werden.

Note:

d = 6 to 18 with two coolant channels

d = 20 to 40 with four coolant channels

For tools with through coolant an O-ring must be used.

Observation:

d = 6 bis 18 avec deux canaux d'arrosage

d = 20 bis 40 avec quatre canaux d'arrosage

Pour outils avec arrosage interne il faut utiliser un joint torique.



**Verwendung:**

Zum Spannen von zylindrischen Werkzeugschäften mit geneigter Spannfläche nach DIN 1835 Form E (Whistle Notch).

Application:

For mounting straight-shank tools and inclined flat according to DIN 1835 form E (Whistle Notch).

Application:

Pour le serrage d'outils avec queue cylindrique et avec méplat incliné suivant DIN 1835 forme E (Whistle Notch).

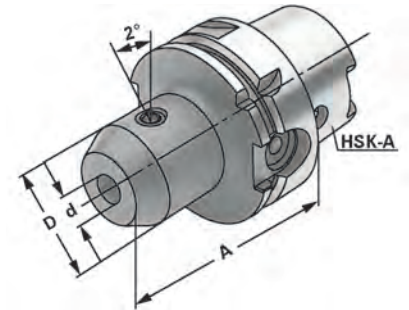
ISO 12164-1
(DIN 69893-1)

HSK - A

 $\nabla \leq 0,003$ G6,3
15.000 min⁻¹

14.04

5

Bestell-Nr. Order no. Référence	HSK	d ^{H4}	A	D
A32.05.06	HSK-A 32	6	80	25
A32.05.08	HSK-A 32	8	80	28
A32.05.10	HSK-A 32	10	80	32
A32.05.12	HSK-A 32	12	80	32
A32.05.14	HSK-A 32	14	80	32
A32.05.16	HSK-A 32	16	90	32
A32.05.18	HSK-A 32	18	90	34
A32.05.20	HSK-A 32	20	90	34
A40.05.06	HSK-A 40	6	80	25
A40.05.08	HSK-A 40	8	80	28
A40.05.10	HSK-A 40	10	80	35
A40.05.12	HSK-A 40	12	90	42
A40.05.14	HSK-A 40	14	90	44
A40.05.16	HSK-A 40	16	90	48
A40.05.18	HSK-A 40	18	90	40
A40.05.20	HSK-A 40	20	90	40
A40.05.25	HSK-A 40	25	100	46
A40.05.32	HSK-A 40	32	110	54
A50.05.06	HSK-A 50	6	80	25
A50.05.08	HSK-A 50	8	80	28
A50.05.10	HSK-A 50	10	80	35
A50.05.12	HSK-A 50	12	90	42
A50.05.14	HSK-A 50	14	90	44
A50.05.16	HSK-A 50	16	90	48
A50.05.18	HSK-A 50	18	90	50
A50.05.20	HSK-A 50	20	100	52
A50.05.25	HSK-A 50	25	110	60
A50.05.32	HSK-A 50	32	110	60

Hinweis: Ab d = 25 mit zwei Spannschrauben
Note: From d = 25 on two clamping screws
Observation: A partir de d = 25 avec deux vis de serrage

Lieferumfang: Mit Spannschraube und axialer Verstellechraube
Delivery: With clamping screw and axial adjustment bolt
Livraison: Avec vis de serrage et vis de butée axiale



End mill holders DIN 6359 for end mills DIN 1835-E

DIN 69893 (HSK-A)

Porte-fraises DIN 6359 pour queues cylindriques DIN 1835-E

**Verwendung:**

Zum Spannen von zylindrischen Werkzeugschäften mit geneigter Spannfläche nach DIN 1835 Form E (Whistle Notch).

Application:

For mounting straight-shank tools and inclined flat according to DIN 1835 form E (Whistle Notch).

Application:

Pour le serrage d'outils avec queue cylindrique et avec méplat incliné suivant DIN 1835 forme E (Whistle Notch).

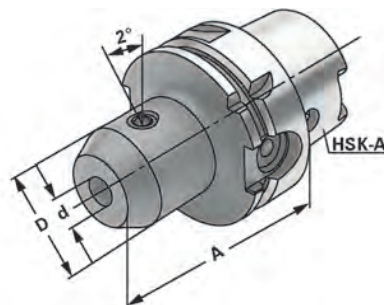
ISO 12164-1
(DIN 69893-1)

HSK - A

 $\nabla \leq 0,003$ G6.3
15.000 min⁻¹

14.04

Bestell-Nr. Order no. Référence	HSK	d ^{H4}	A	D
A63.05.06	HSK-A 63	6	80	25
A63.05.08	HSK-A 63	8	80	28
A63.05.10	HSK-A 63	10	80	35
A63.05.12	HSK-A 63	12	90	42
A63.05.14	HSK-A 63	14	90	44
A63.05.16	HSK-A 63	16	100	48
A63.05.18	HSK-A 63	18	100	50
A63.05.20	HSK-A 63	20	100	52
A63.05.25	HSK-A 63	25	110	65
A63.05.32	HSK-A 63	32	110	72
A80.05.06	HSK-A 80	6	90	25
A80.05.08	HSK-A 80	8	90	28
A80.05.10	HSK-A 80	10	90	35
A80.05.12	HSK-A 80	12	100	42
A80.05.14	HSK-A 80	14	100	44
A80.05.16	HSK-A 80	16	100	48
A80.05.18	HSK-A 80	18	100	50
A80.05.20	HSK-A 80	20	110	52
A80.05.25	HSK-A 80	25	110	65
A80.05.32	HSK-A 80	32	120	72
A100.05.06	HSK-A 100	6	90	25
A100.05.08	HSK-A 100	8	90	28
A100.05.10	HSK-A 100	10	90	35
A100.05.12	HSK-A 100	12	100	42
A100.05.14	HSK-A 100	14	100	44
A100.05.16	HSK-A 100	16	100	48
A100.05.18	HSK-A 100	18	100	50
A100.05.20	HSK-A 100	20	110	52
A100.05.25	HSK-A 100	25	120	65
A100.05.32	HSK-A 100	32	120	72
A100.05.40	HSK-A 100	40	120	80

Hinweis: Ab d = 25 mit zwei Spanschrauben**Note:** From d = 25 on two clamping screws**Observation:** A partir de d = 25 avec deux vis**Lieferumfang:** Mit Spanschraube und axialer Verstellerschraube**Delivery:** With clamping screw and axial adjustment bolt**Livraison:** Avec vis de serrage et vis de butée axiale



Verwendung:

Zur Aufnahme von Einschraubfräser mit Gewinde.

Application:

For mounting screw-in cutters with thread.

Application:

Pour le serrage de fraises à queue fileté.

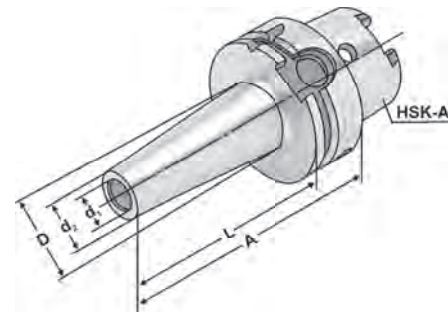

ISO 12164-1
(DIN 69893-1)

HSK - A

$\lambda \leq 0,003$

G6.3
15.000 min⁻¹

5

Bestell-Nr. Order no. Référence	HSK	M	d ₁ ^{H4}	d ₂	D	A	L
A63.06.06	HSK-A 63	6	6,5	10	13	51	25
A63.06.08	HSK-A 63	8	8,5	13	15	51	25
A63.06.08.1	HSK-A 63	8	8,5	13	23	76	50
A63.06.08.2	HSK-A 63	8	8,5	13	23	101	75
A63.06.10	HSK-A 63	10	10,5	18	20	51	25
A63.06.10.1	HSK-A 63	10	10,5	18	23	76	50
A63.06.10.3	HSK-A 63	10	10,5	18	32	126	100
A63.06.10.5	HSK-A 63	10	10,5	18	37	176	150
A63.06.12	HSK-A 63	12	12,5	21	24	51	25
A63.06.12.1	HSK-A 63	12	12,5	21	24	76	50
A63.06.12.2	HSK-A 63	12	12,5	21	31	101	75
A63.06.12.3	HSK-A 63	12	12,5	21	33	126	100
A63.06.12.5	HSK-A 63	12	12,5	21	40	176	150
A63.06.16	HSK-A 63	16	17	29	29	51	25
A63.06.16.1	HSK-A 63	16	17	29	34	76	50
A63.06.16.2	HSK-A 63	16	17	29	34	101	75
A63.06.16.3	HSK-A 63	16	17	29	36	126	100
A63.06.16.5	HSK-A 63	16	17	29	43	176	150
A100.06.08.1	HSK-A 100	8	8,5	13	23	79	50
A100.06.10.1	HSK-A 100	10	10,5	18	23	79	50
A100.06.10.3	HSK-A 100	10	10,5	18	32	129	100
A100.06.10.5	HSK-A 100	10	10,5	18	37	179	150
A100.06.12.1	HSK-A 100	12	12,5	21	24	79	50
A100.06.12.3	HSK-A 100	12	12,5	21	33	129	100
A100.06.12.5	HSK-A 100	12	12,5	21	40	179	150
A100.06.16.1	HSK-A 100	16	17	29	34	79	50
A100.06.16.3	HSK-A 100	16	17	29	36	129	100
A100.06.16.5	HSK-A 100	16	17	29	43	179	150

**Empfohlenes Anzugsmoment
Recommended tightening torques
Torques de serrage recommandés**

M6	10 Nm
M8	25 Nm
M10	40 Nm
M12	60 Nm
M16	50 Nm





Combi shell mill holders DIN 6358
 Porte-fraises à double usage DIN 6358

DIN 69893 (HSK-A)



Verwendung:
 Zur Aufnahme von Walzen-, Walzenstirnfräsern oder Messerköpfen mit Längs- oder Quernut.

Application:
 For mounting milling cutters with transverse or longitudinal groove.

Application:
 Pour le serrage de fraises à rainure transversale ou à rainure longitudinale.

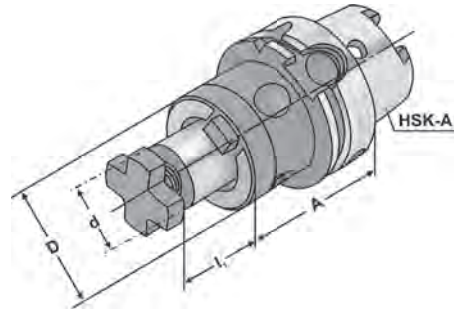

ISO 12164-1 (DIN 69893-1) HSK - A $\lambda \leq 0,005$ G6,3 15.000 min⁻¹

Bestell-Nr. Order no. Référence	HSK	d _{h6}	A	l ₁	D
A32.10.16	HSK-A 32	16	55	17	32
A32.10.22	HSK-A 32	22	55	19	40
A32.10.27	HSK-A 32	27	65	21	48
A32.10.32	HSK-A 32	32	65	24	58
A32.10.40	HSK-A 32	40	65	27	70
A40.10.16	HSK-A 40	16	50	17	32
A40.10.22	HSK-A 40	22	50	19	40
A40.10.27	HSK-A 40	27	65	21	48
A40.10.32	HSK-A 40	32	65	24	58
A50.10.16	HSK-A 50	16	50	17	32
A50.10.22	HSK-A 50	22	50	19	40
A50.10.27	HSK-A 50	27	65	21	48
A50.10.32	HSK-A 50	32	65	24	58
A63.10.16	HSK-A 63	16	60	17	32
A63.10.22	HSK-A 63	22	60	19	40
A63.10.27	HSK-A 63	27	60	21	48
A63.10.32	HSK-A 63	32	60	24	58
A63.10.40	HSK-A 63	40	70	27	70
A63.10.16.1	HSK-A 63	16	100	17	32
A63.10.22.1	HSK-A 63	22	100	19	40
A63.10.27.1	HSK-A 63	27	100	21	48
A63.10.32.1	HSK-A 63	32	100	24	58
A80.10.16	HSK-A 80	16	60	17	32
A80.10.22	HSK-A 80	22	60	19	40
A80.10.27	HSK-A 80	27	60	21	48
A80.10.32	HSK-A 80	32	60	24	58
A80.10.40	HSK-A 80	40	70	27	70
A100.10.16	HSK-A 100	16	60	17	32
A100.10.22	HSK-A 100	22	60	19	40
A100.10.27	HSK-A 100	27	60	21	48
A100.10.32	HSK-A 100	32	60	24	58
A100.10.40	HSK-A 100	40	70	27	70

Lieferumfang: Mit Fräseranzugsschraube, Mitnehmerring und Passfeder
Delivery: With tightening bolt, driving ring and feather key
Livraison: Avec vis de blocage, bague d'entraînement et clavette





Shell mill holders DIN 6357 with enlarged contact face and coolant exit bores on the end face

Porte-fraises à trou lisse DIN 6357 avec face de contact élargie et conduits pour l'arrosage frontal



Verwendung:

Zur Aufnahme von Messerköpfen und Fräsern mit Quernut.

Application:

For mounting milling cutters with transversal groove.

Application:

Pour le serrage de fraises à rainure transversale.

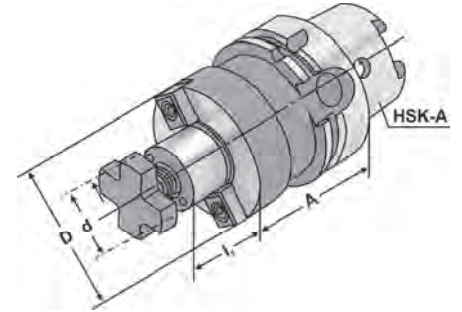

ISO 12164-1
(DIN 69893-1)

HSK - A

$\nabla \leq 0,005$

G6,3
15.000 min⁻¹

5

Bestell-Nr. Order no. Référence	HSK	d _{H6}	A	l ₁	D
A40.11.22	HSK-A 40	22	50	19	48
A40.11.27	HSK-A 40	27	55	21	60
A40.11.32	HSK-A 40	32	60	24	78
A50.11.16	HSK-A 50	16	50	17	40
A50.11.22	HSK-A 50	22	60	19	48
A50.11.27	HSK-A 50	27	60	21	60
A50.11.32	HSK-A 50	32	60	24	78
A63.11.16	HSK-A 63	16	50	17	38
A63.11.22	HSK-A 63	22	50	19	48
A63.11.27	HSK-A 63	27	60	21	58
A63.11.32	HSK-A 63	32	60	24	78
A63.11.40	HSK-A 63	40	60	27	88
A63.11.16.1	HSK-A 63	16	100	17	38
A63.11.22.1	HSK-A 63	22	100	19	48
A63.11.27.1	HSK-A 63	27	100	21	58
A63.11.32.1	HSK-A 63	32	100	24	78
A63.11.40.1	HSK-A 63	40	100	27	88
A63.11.16.2	HSK-A 63	16	160	17	38
A63.11.22.2	HSK-A 63	22	160	19	48
A63.11.27.2	HSK-A 63	27	160	21	58
A63.11.32.2	HSK-A 63	32	160	24	78
A63.11.40.2	HSK-A 63	40	160	27	88

d = 40:

Für große Planfräser mit vier zusätzlichen Gewindebohrungen nach DIN 2079.

For large diameter face mill cutters with four additional threaded holes according to DIN 2079.

Pour fraises à surfacer à grands diamètres avec quatre trous taraudés additionnels suivant DIN 2079.

Lieferumfang: Mit Mitnehmersteinen, Kreuzschraube und Zylinderkopfschraube nach DIN 912 für Fräser mit innerer Kühlmittelzufuhr.

Delivery: With drivers, cross head retaining screw and cylinder head retaining screw for cutters with central coolant.

Livraison: Avec tenons, une vis cruciforme et une vis à tête cylindrique suivant DIN 912 pour fraises avec arrosage central.

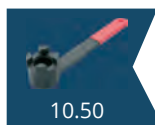

10.50



10.48



10.49

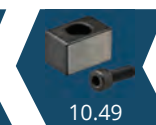

10.49



5.45





Shell mill holders DIN 6357 with enlarged contact face and coolant exit bores on the end face
 Porte-fraises à trou lisse DIN 6357 avec face de contact élargie et conduits pour l'arrosage frontal



Verwendung:
 Zur Aufnahme von Messerköpfen und Fräsern mit Quernut.
Application:
 For mounting milling cutters with transversal groove.
Application:
 Pour le serrage de fraises à rainure transversale.

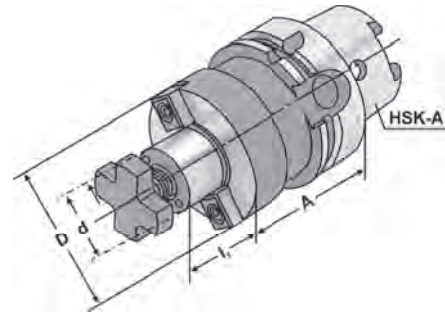

ISO 12164-1 (DIN 69893-1) HSK - A $\lambda \leq 0,005$ G6,3 15.000 min⁻¹

Bestell-Nr. Order no. Référence	HSK	d _{H6}	A	l ₁	D
A80.11.22	HSK-A 80	22	50	19	48
A80.11.27	HSK-A 80	27	50	21	58
A80.11.32	HSK-A 80	32	60	24	78
A80.11.40	HSK-A 80	40	60	27	88
A100.11.16	HSK-A 100	16	50	17	38
A100.11.22	HSK-A 100	22	50	19	48
A100.11.27	HSK-A 100	27	50	21	58
A100.11.32	HSK-A 100	32	50	24	78
A100.11.40	HSK-A 100	40	70	27	88
A100.11.60	HSK-A 100	60	70	40	130
A100.11.16.1	HSK-A 100	16	100	17	38
A100.11.22.1	HSK-A 100	22	100	19	48
A100.11.27.1	HSK-A 100	27	100	21	58
A100.11.32.1	HSK-A 100	32	100	24	78
A100.11.40.1	HSK-A 100	40	100	27	88



d = 40/d = 60: Für große Planfräser mit vier zusätzlichen Gewindebohrungen nach DIN 2079.
 For large diameter face mill cutters with four additional threaded holes according to DIN 2079.
 Pour fraises à surfacer à grands diamètres avec quatre trous taraudés additionnels suivant DIN 2079.

Lieferumfang: Mit Mitnehmersteinen, Kreuzschraube und Zylinderkopfschraube nach DIN 912 für Fräser mit innerer Kühlmittelzufuhr.
 Bei d = 60 nur mit vier Befestigungsschrauben nach DIN 912.

Delivery: With drivers, cross head retaining screw and cylinder head retaining screw for cutters with central coolant.
 For d = 60 only with four fixation screws according to DIN 912.

Livraison: Avec tenons, une vis cruciforme et une vis à tête cylindrique suivant DIN 912 pour fraises avec arrosage central.
 Pour d = 60 seulement avec quatre vis de fixation suivant DIN 912.





Verwendung:
Zur Aufnahme von Werkzeugen mit Morsekegelschaft und Austreiblappen nach DIN 228-1 Form B.

Application:
For mounting tools with Morse taper shank and tang according to DIN 228-1 form B.

Application:
Pour le serrage d'outils avec queue cône Morse et tenon suivant DIN 228-1 forme B.

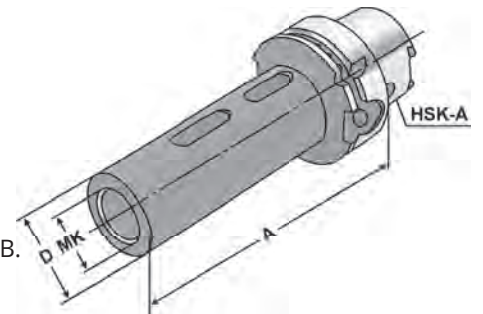

ISO 12164-1
(DIN 69893-1)

HSK - A

$\nabla \leq 0,005$

G6,3
15.000 min⁻¹

5

Bestell-Nr. Order no. Référence	HSK	MK MT CM	A	D
A50.07.01	HSK-A 50	1	100	25
A50.07.02	HSK-A 50	2	120	32
A50.07.03	HSK-A 50	3	140	40
A63.07.01	HSK-A 63	1	100	25
A63.07.02	HSK-A 63	2	120	32
A63.07.03	HSK-A 63	3	140	40
A63.07.04	HSK-A 63	4	160	48
A80.07.01	HSK-A 80	1	110	25
A80.07.02	HSK-A 80	2	120	32
A80.07.03	HSK-A 80	3	140	40
A80.07.04	HSK-A 80	4	160	48
A100.07.01	HSK-A 100	1	110	25
A100.07.02	HSK-A 100	2	120	32
A100.07.03	HSK-A 100	3	150	40
A100.07.04	HSK-A 100	4	170	48
A100.07.05	HSK-A 100	5	200	63





Adaptor sleeves for MT with drawbar thread DIN 6364
 Douilles de réduction pour CM avec filetage DIN 6364



Verwendung:
 Zum Spannen von Werkzeugen mit Morsekegelschaft und Anzugsgewinde nach DIN 228-1 Form A.

Application:
 For clamping tools with Morse taper shank and thread according to DIN 228-1 form A.

Application:
 Pour le serrage d'outils avec queue cône Morse et filetage suivant DIN 228-1 forme A.

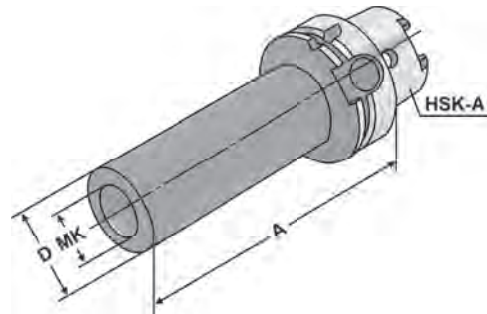

ISO 12164-1 (DIN 69893-1) HSK - A $\lambda \leq 0,005$ G6,3 15.000 min⁻¹

Bestell-Nr. Order no. Référence	HSK	MK MT CM	M	A	D
A50.08.01	HSK-A 50	1	M6	100	25
A50.08.02	HSK-A 50	2	M10	120	32
A50.08.03	HSK-A 50	3	M12	140	40
A63.08.01	HSK-A 63	1	M6	100	25
A63.08.02	HSK-A 63	2	M10	120	32
A63.08.03	HSK-A 63	3	M12	140	40
A63.08.04	HSK-A 63	4	M16	160	48
A80.08.01	HSK-A 80	1	M6	110	25
A80.08.02	HSK-A 80	2	M10	120	32
A80.08.03	HSK-A 80	3	M12	150	40
A80.08.04	HSK-A 80	4	M16	170	48
A100.08.01	HSK-A 100	1	M6	110	25
A100.08.02	HSK-A 100	2	M10	120	32
A100.08.03	HSK-A 100	3	M12	150	40
A100.08.04	HSK-A 100	4	M16	170	48
A100.08.05	HSK-A 100	5	M20	200	63



Lieferumfang: Mit eingebauter Fräseranzugsschraube
Delivery: With built-in tightening bolt
Livraison: Avec vis de serrage montée





Quick change tapping chucks with length compensation on compression and expansion

Mandrins de taraudage à changement rapide avec compensation longitudinale à la compression et traction



Verwendung:

Zur Aufnahme von Schnellwechsel-Ein-sätzen für Gewindebohrer.

Application:

For the chucking of quick change adaptors for taps.

Application:

Pour le serrage d'adaptateurs porte-tarands à changement rapide.

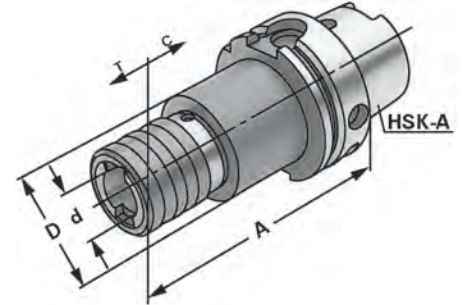

ISO 12164-1
(DIN 69893-1)

HSK - A



5

Bestell-Nr. Order no. Référence	HSK	Spannbereich Capacity Capacité	Größe Size Taille	A	D	d	C	T
A32.16.12	HSK-A 32	M3 - M14	1	80	41	19	7	7
A40.16.12	HSK-A 40	M3 - M14	1	80	41	19	7	7
A40.16.20	HSK-A 40	M5 - M22	2	103	60	19	10	10
A50.16.12	HSK-A 50	M3 - M14	1	72	38	19	7	7
A50.16.20	HSK-A 50	M5 - M22	2	110	54	31	12	12
A63.16.12	HSK-A 63	M3 - M14	1	102	50	19	7	7
A63.16.20	HSK-A 63	M5 - M22	2	140	54	31	12	12
A63.16.36	HSK-A 63	M14 - M36	3	210	86	48	17,5	17,5
A80.16.12	HSK-A 80	M3 - M14	1	72	41	19	7	7
A80.16.20	HSK-A 80	M5 - M22	2	108	60	31	10	10
A80.16.36	HSK-A 80	M14 - M36	3	141	86	48	17,5	17,5
A100.16.12	HSK-A 100	M3 - M14	1	112	38	19	7	7
A100.16.20	HSK-A 100	M5 - M22	2	148	54	31	12	12
A100.16.36	HSK-A 100	M14 - M36	3	210	86	48	17,5	17,5

Hinweis: Für Bearbeitungszentren ohne Synchronspindel.
Note: For machining centres without synchronous spindle.
Observation: Pour centres d'usinage sans broche synchrone.





Quick change tapping chucks without length compensation on compression and expansion
 Mandrins de taraudage à changement rapide sans compensation longitudinale à la compression et traction



Verwendung:
 Zur Aufnahme von Schnellwechsel-Ein-
 sätzen für Gewindebohrer.
Application:
 For the chucking of quick change adaptors
 for taps.
Application:
 Pour le serrage d'adaptateurs porte-
 tarauds à changement rapide.

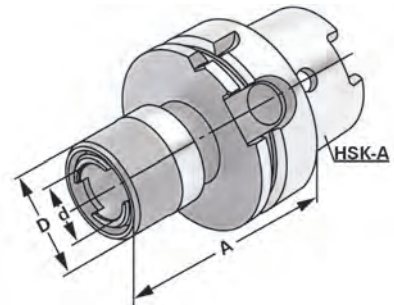

ISO 12164-1
 (DIN 69893-1)

HSK - A

14.04

Bestell-Nr. Order no. Référence	HSK	Spannbereich Capacity Capacité	Größe Size Taille	A	D	d
A50.16.12.1	HSK-A 50	M3 – M14	1	65	38	19
A50.16.20.1	HSK-A 50	M5 – M22	2	100	54	31
A63.16.12.1	HSK-A 63	M3 – M14	1	65	38	19
A63.16.20.1	HSK-A 63	M5 – M22	2	100	54	31
A100.16.12.1	HSK-A 100	M3 – M14	1	80	38	19
A100.16.20.1	HSK-A 100	M5 – M22	2	90	54	31
A100.16.36.1	HSK-A 100	M14 – M36	3	130	86	48



Hinweis: Für Bearbeitungszentren mit Synchronspindel.
Note: For machining centres with synchronous spindle.
Observation: Pour centres d'usinage avec broche synchrone.

Gewuchtete Ausführung



Balanced type
 Type équilibré

Bestell-Nr. Order no. Référence	Abmessung Size Dimension
---------------------------------------	--------------------------------

- Wuchten auf G 2,5 von vorgewuchteten Kemmler-Werkzeugen
 Balancing at G 2.5 of pre-balanced Kemmler-tools
 Equilibrage sur G 2,5 d'outils Kemmler pré-équilibrés
- W25 **Ohne Wuchtprotokoll**
 Without balancing report
 Sans protocole d'équilibrage
- W25.2 **Mit Wuchtprotokoll**
 With balancing report
 Avec protocole d'équilibrage
- Wuchten von nicht vorgewuchteten Werkzeugen
 Balancing of unbalanced tools
 Equilibrage d'outils non-équilibrés
- W25.1 **Ohne Wuchtprotokoll**
 Without balancing report
 Sans protocole d'équilibrage





Tapping chucks for synchronisation for collets DIN 6499 (ISO 15488) ER-system

Mandrins de taraudage pour synchronisation pour pinces DIN 6499 (ISO 15488) système ER

**Verwendung:**

Für Bearbeitungszentren mit Synchronspindel.

Application:

For machining centres with synchronous spindle.

Application:

Pour centres d'usinage avec broche synchrone.

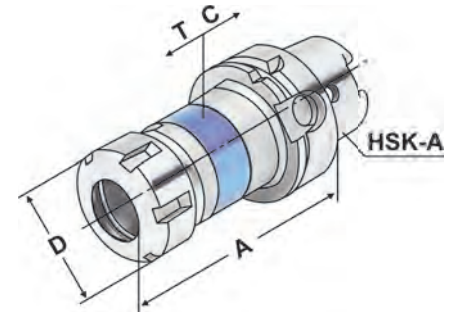
ISO 12164-1
(DIN 69893-1)

HSK - A

 $\nabla \leq 0,060$ G6,3
15.000 min⁻¹

5

Bestell-Nr. Order no. Référence	HSK	Spannbereich Capacity Capacité	A	D	T	C
A40.16.02.10	HSK-A 40	M3 – M12 (ER 16)	87	28	0,5	0,5
A40.16.02.13	HSK-A 40	M3 – M16 (ER 20)	93	34	0,5	0,5
A50.16.02.10	HSK-A 50	M3 – M12 (ER 16)	87	28	0,5	0,5
A50.16.02.13	HSK-A 50	M3 – M16 (ER 20)	88	34	0,5	0,5
A50.16.02.16	HSK-A 50	M3 – M20 (ER 25)	92	42	0,5	0,5
A50.16.02.20	HSK-A 50	M3 – M27 (ER 32)	116	50	0,5	0,5
A63.16.02.10 ¹	HSK-A 63	M3 – M12 (ER 16) SW25	93	28	0,5	0,5
A63.16.02.10.M ²	HSK-A 63	M3 – M12 (ER 16) Mini	93	22	0,5	0,5
A63.16.02.10.1.M ²	HSK-A 63	M3 – M12 (ER 16) Mini	100	22	0,5	0,5
A63.16.02.13	HSK-A 63	M3 – M16 (ER 20)	94	34	0,5	0,5
A63.16.02.16	HSK-A 63	M3 – M20 (ER 25)	98	42	0,5	0,5
A63.16.02.20	HSK-A 63	M3 – M27 (ER 32)	108	50	0,5	0,5
A63.16.02.26	HSK-A 63	M3 – M33 (ER 40)	133,5	63	0,5	0,5
A80.16.02.13	HSK-A 80	M3 – M16 (ER 20)	100	34	0,5	0,5
A80.16.02.16	HSK-A 80	M3 – M20 (ER 25)	105	42	0,5	0,5
A80.16.02.20	HSK-A 80	M3 – M27 (ER 32)	110,5	50	0,5	0,5
A80.16.02.26	HSK-A 80	M3 – M33 (ER 40)	131	63	0,5	0,5
A100.16.02.10 ¹	HSK-A 100	M3 – M12 (ER 16) SW25	100	28	0,5	0,5
A100.16.02.10.M ²	HSK-A 100	M3 – M12 (ER 16) Mini	100	22	0,5	0,5
A100.16.02.10.1.M ²	HSK-A 100	M3 – M12 (ER 16) Mini	106	22	0,5	0,5
A100.16.02.13	HSK-A 100	M3 – M16 (ER 20)	101	34	0,5	0,5
A100.16.02.16	HSK-A 100	M3 – M20 (ER 25)	105	42	0,5	0,5
A100.16.02.20	HSK-A 100	M3 – M27 (ER 32)	110	50	0,5	0,5
A100.16.02.20.1	HSK-A 100	M3 – M27 (ER 32)	160	50	0,5	0,5
A100.16.02.20.2	HSK-A 100	M3 – M27 (ER 32)	190	50	0,5	0,5
A100.16.02.26	HSK-A 100	M3 – M33 (ER 40)	136	63	0,5	0,5

Lieferumfang: Mit gewichteter Spannmutter
Delivery: With balanced clamping nut
Livraison: Avec écrou de serrage équilibré

¹ Sechskantmutter
¹ Hexagonal clamping nut
¹ Écrous hexagonal

² Minimutter
² Mini nut
² Écrous mini



9.03



10.11



10.22



10.39



5.45



Verwendung:
Zur Aufnahme von allen nach DIN 6595 genormten Vollbohrern mit Zylinderschaft.

Application:
For all solid drills with cylindrical shank according to DIN 6595.

Application:
Pour le serrage de forets à queue cylindrique suivant DIN 6595.

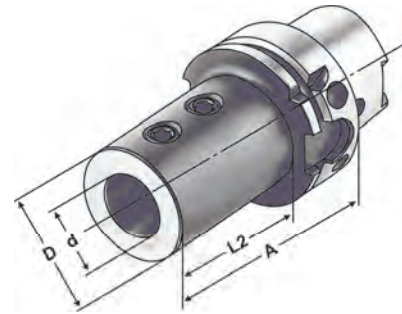

ISO 12164-1
(DIN 69893-1)

HSK - A

$\nabla \leq 0,005$

G6,3
15.000 min⁻¹

Bestell-Nr.
Order no.
Référence

HSK

d

A

D

L2

A63.51.20

HSK-A 63

20

80

40

54

A63.51.25

HSK-A 63

25

90

45

59

A63.51.32

HSK-A 63

32

90

52

63

A63.51.40

HSK-A 63

40

105

63

73

5

Lieferumfang: Mit Spannschrauben
Delivery: With clamping screws
Livraison: Avec vis de serrage





Verwendung:
Zur Aufnahme von Werkzeugen mit Zylinderschaft.

Application:
For mounting tools with straight shanks.

Application:
Pour le serrage d'outils avec queue cylindrique.

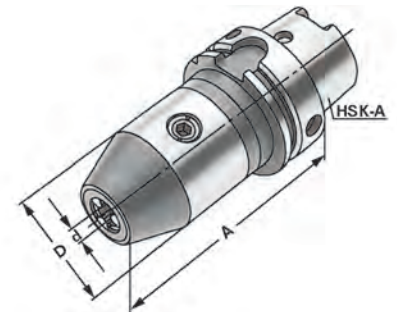

ISO 12164-1
(DIN 69893-1)

HSK - A

$\nabla \leq 0,030$

G6,3
15.000 min⁻¹

14.04

5

Bestell-Nr. Order no. Référence	HSK	Spannbereich Capacity Capacité	A	D
A32.15.08	HSK-A 32	0 - 8	90	36
A40.15.08	HSK-A 40	0 - 8	90	36
A40.15.13	HSK-A 40	1,0 - 13	121	50
A40.15.16	HSK-A 40	2,5 - 16	126	50
A50.15.08	HSK-A 50	0 - 8	90	36
A50.15.13	HSK-A 50	1,0 - 13	116	50
A50.15.16	HSK-A 50	2,5 - 16	116	50
A63.15.08	HSK-A 63	0 - 8	85	36
A63.15.13	HSK-A 63	1,0 - 13	104	50
A63.15.16	HSK-A 63	2,5 - 16	109	50
A80.15.13	HSK-A 80	1,0 - 13	109	50
A80.15.16	HSK-A 80	2,5 - 16	114	50
A100.15.13	HSK-A 100	1,0 - 13	107	50
A100.15.16	HSK-A 100	2,5 - 16	112	50

Hinweis: Hohe Präzision und Rundlaufgenauigkeit von $\leq 0,03$ mm. Sichere Spannung des Werkzeuges durch mechanische Spannkraftverstärkung. Kein selbständiges Lösen der Spannung während der Bearbeitung bei Links- oder Rechtslauf, sowie bei Spindelstop. Spannen und Lösen mit Sechskantschlüssel.

Note: High precision and accurate concentricity of ≤ 0.03 mm. Secure gripping of the tool through mechanical amplification of the clamping force. No automatic slackening of the clamping force while machining with either clockwise or counter clockwise rotation or on spindle stop. Clamping and releasing effected by means of an Allen wrench.

Observation: Précision élevée et exactitude de circularité de $\leq 0,03$ mm. Serrage sûr de l'outil grâce à l'amplification de la force de serrage. Pas de desserrage intempestif en cours d'usinage lors de la rotation la gauche ou la droite, de même qu'en cas d'arrêt de la broche. Serrage et desserrage en utilisant un clé sur à fourche.

Lieferumfang: Mit Spannschlüssel
Delivery: With wrench
Livraison: Avec clé de serrage





Verwendung:
Zur Herstellung von Sonderwerkzeugen.

Application:
For the manufacturing of special tools.

Application:
Pour la fabrication d'outils spéciaux.

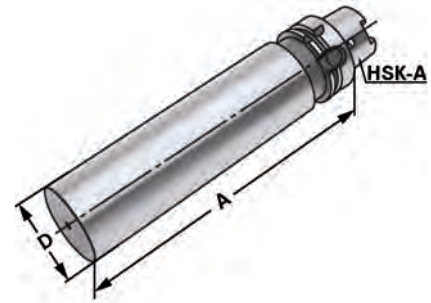
 ISO 12164-1
 (DIN 69893-1)

HSK - A

 Bestell-Nr.
 Order no.
 Référence

HSK

D

A

A32.17.25	HSK-A 32	32,5	100
A40.17.40	HSK-A 40	40,5	160
A50.17.50	HSK-A 50	50,5	200
A63.17.63	HSK-A 63	63,5	250
A63.17.80	HSK-A 63	80,0	250
A80.17.80	HSK-A 80	80,5	250
A100.17.97	HSK-A 100	97,5	250

5

Ausführung: Kegel und Bund gehärtet und geschliffen. Schaft weich zur weiteren Bearbeitung.
Version: *Cone and flange hardened and grinded. Soft body for later processing.*
Version: Cône et collerette durcis et rectifiés. Corps doux pour un usinage ultérieur.



Verwendung:
Zur Aufnahme von Werkzeugen mit Zylinderschaft nach DIN 1835 Form A+B+E und DIN 6535 Form HB+HE (größer Ø 20 mm nur mit Reduzierung).

Application:
For mounting straight-shank tools acc. DIN 1835 form A+B+E and DIN 6535 form HB+HE (larger than Ø 20 mm only with reduction sleeve).

Application:
Pour le serrage d'outils avec queue cylindrique suivant DIN 1835 forme A+B+E et DIN 6535 forme HB+HE (à partir de Ø 20 mm seulement avec réduction).

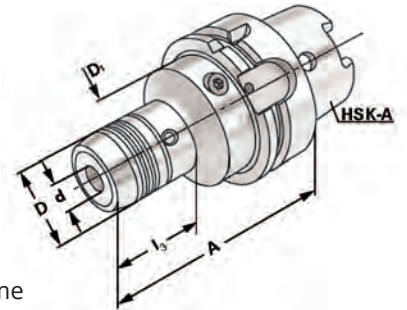

ISO 12164-1
(DIN 69893-1)

HSK - A

$\nabla \leq 0,003$

G6,3
15.000 min⁻¹

14.04

5

Bestell-Nr. Order no. Référence	HSK	d	A	D	D ₁	l ₁	l ₂	l ₃
A32.H06	HSK-A 32	6	80	26	26	37	10	20
A32.H08	HSK-A 32	8	80	28	26	37	10	35
A32.H10	HSK-A 32	10	85	30	26	42	10	35
A32.H12	HSK-A 32	12	90	32	26	47	10	35
A32.H14	HSK-A 32	14	95	34	26	47	10	45
A32.H16	HSK-A 32	16	100	38	26	52	10	45
A32.H20	HSK-A 32	20	100	42	42	52	10	45
A40.H06	HSK-A 40	6	80	26	34	37	10	45
A40.H08	HSK-A 40	8	80	28	34	37	10	44
A40.H10	HSK-A 40	10	85	30	34	42	10	44
A40.H12	HSK-A 40	12	90	32	34	47	10	43
A40.H14	HSK-A 40	14	90	34	34	47	10	41
A40.H16	HSK-A 40	16	90	38	34	52	10	38
A40.H18	HSK-A 40	18	90	40	34	52	10	38
A40.H20	HSK-A 40	20	90	42	34	52	10	16
A50.H06	HSK-A 50	6	80	26	42	37	10	45
A50.H08	HSK-A 50	8	80	28	42	37	10	44
A50.H10	HSK-A 50	10	85	30	42	42	10	44
A50.H12	HSK-A 50	12	90	32	42	47	10	43
A50.H14	HSK-A 50	14	90	34	42	47	10	41
A50.H16	HSK-A 50	16	95	38	42	52	10	43
A50.H18	HSK-A 50	18	95	40	42	52	10	43
A50.H20	HSK-A 50	20	100	42	42	52	10	26
A50.H25	HSK-A 50	25	120	50	42	58	10	26

Lieferumfang: Mit Spannschlüssel
Delivery: With wrench
Livraison: Avec clé de serrage

l₁ = max. Einstecktiefe
l₁ = max. clamping depth
l₁ = max. profondeur d'insertion

l₂ = max. Verstellweg
l₂ = max. length adjustment range
l₂ = max. course de réglage

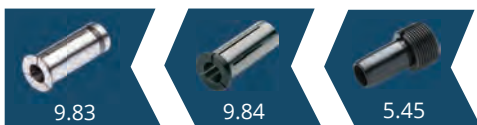



Verwendung:
Zur Aufnahme von Werkzeugen mit Zylinderschaft nach DIN 1835 Form A+B+E und DIN 6535 Form HB+HE (größer Ø 20 mm nur mit Reduzierung).

Application:
For mounting straight-shank tools acc. DIN 1835 form A+B+E and DIN 6535 form HB+HE (larger than Ø 20 mm only with reduction sleeve).

Application:
Pour le serrage d'outils avec queue cylindrique suivant DIN 1835 forme A+B+E et DIN 6535 forme HB+HE (à partir de Ø 20 mm seulement avec réduction).

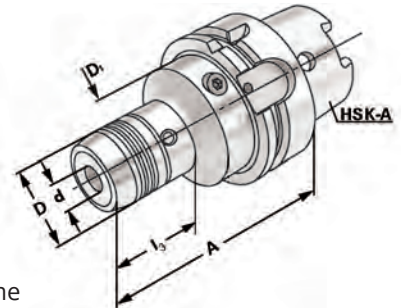

ISO 12164-1 (DIN 69893-1) HSK - A $\lambda \leq 0,003$ G6,3 15.000 min⁻¹ ⓘ 14.04

Bestell-Nr. Order no. Référence	HSK	d	A	D	D ₁	l ₁	l ₂	l ₃
A63.H06	HSK-A 63	6	80	26	50	37	10	47
A63.H08	HSK-A 63	8	80	28	50	37	10	47
A63.H10	HSK-A 63	10	85	30	50	42	10	46
A63.H12	HSK-A 63	12	90	32	50	47	10	46
A63.H14	HSK-A 63	14	90	34	50	47	10	44
A63.H16	HSK-A 63	16	95	38	50	52	10	43
A63.H18	HSK-A 63	18	95	40	50	52	10	43
A63.H20	HSK-A 63	20	100	42	50	52	10	42
A63.H25	HSK-A 63	25	120	50	50	58	10	26
A63.H32	HSK-A 63	32	125	60	50	62	10	42
A63.H06.1	HSK-A 63	6	150	26	50	37	10	47
A63.H08.1	HSK-A 63	8	150	28	50	37	10	46
A63.H10.1	HSK-A 63	10	150	30	50	42	10	46
A63.H12.1	HSK-A 63	12	150	32	50	47	10	45
A63.H14.1	HSK-A 63	14	150	34	50	47	10	45
A63.H16.1	HSK-A 63	16	150	38	50	52	10	43,5
A63.H18.1	HSK-A 63	18	150	40	50	52	10	43
A63.H20.1	HSK-A 63	20	150	42	50	52	10	42
A63.H25.1	HSK-A 63	25	150	50	50	58	10	-
A63.H06.2	HSK-A 63	6	200	26	50	37	10	47
A63.H08.2	HSK-A 63	8	200	28	50	37	10	46
A63.H10.2	HSK-A 63	10	200	30	50	42	10	46
A63.H12.2	HSK-A 63	12	200	32	50	47	10	45
A63.H14.2	HSK-A 63	14	200	34	50	47	10	45
A63.H16.2	HSK-A 63	16	200	38	50	52	10	43,5
A63.H18.2	HSK-A 63	18	200	40	50	52	10	43
A63.H20.2	HSK-A 63	20	200	42	50	52	10	42
A63.H25.2	HSK-A 63	25	200	50	50	58	10	-

Lieferumfang: Mit Spannschlüssel
Delivery: With wrench
Livraison: Avec clé de serrage

l₁ = max. Einstecktiefe l₂ = max. Verstellweg
l₁ = max. clamping depth l₂ = max. length adjustment range
l₁ = max. profondeur d'insertion l₂ = max. course de réglage





Verwendung:

Zur Aufnahme von Werkzeugen mit Zylinderschaft nach DIN 1835 Form A+B+E und DIN 6535 Form HB+HE (größer Ø 20 mm nur mit Reduzierung).

Application:

For mounting straight-shank tools acc. DIN 1835 form A+B+E and DIN 6535 form HB+HE (larger than Ø 20 mm only with reduction sleeve).

Application:

Pour le serrage d'outils avec queue cylindrique suivant DIN 1835 forme A+B+E et DIN 6535 forme HB+HE (à partir de Ø 20 mm seulement avec réduction).

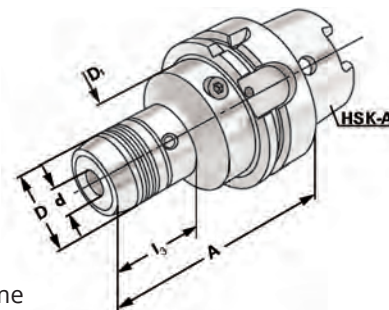

ISO 12164-1
(DIN 69893-1)

HSK - A

$\nabla \leq 0,003$

G6,3
15.000 min⁻¹

14.04

5

Bestell-Nr. Order no. Référence	HSK	d	A	D	D ₁	l ₁	l ₂	l ₃
A80.H06	HSK-A 80	6	85	26	56	37	10	54
A80.H08	HSK-A 80	8	85	28	56	37	10	53
A80.H10	HSK-A 80	10	90	30	56	42	10	53
A80.H12	HSK-A 80	12	95	32	56	47	10	52
A80.H14	HSK-A 80	14	95	34	56	47	10	51
A80.H16	HSK-A 80	16	100	38	56	52	10	50
A80.H18	HSK-A 80	18	100	40	56	52	10	50
A80.H20	HSK-A 80	20	105	42	56	52	10	49
A80.H25	HSK-A 80	25	115	50	56	58	10	62
A80.H32	HSK-A 80	32	120	60	56	62	10	26
A100.H06	HSK-A 100	6	85	26	63	37	10	56
A100.H08	HSK-A 100	8	85	28	63	37	10	56
A100.H10	HSK-A 100	10	90	30	63	42	10	55
A100.H12	HSK-A 100	12	95	32	63	47	10	55
A100.H14	HSK-A 100	14	95	34	63	47	10	53
A100.H16	HSK-A 100	16	100	38	63	52	10	53
A100.H18	HSK-A 100	18	100	40	63	52	10	52
A100.H20	HSK-A 100	20	105	42	63	52	10	51
A100.H25	HSK-A 100	25	115	50	63	58	10	64
A100.H32	HSK-A 100	32	120	60	63	62	10	61
A100.H06.1	HSK-A 100	6	150	26	50	37	10	56
A100.H08.1	HSK-A 100	8	150	28	50	37	10	55,5
A100.H10.1	HSK-A 100	10	150	30	50	42	10	55
A100.H12.1	HSK-A 100	12	150	32	50	47	10	54,5
A100.H14.1	HSK-A 100	14	150	34	50	47	10	53
A100.H16.1	HSK-A 100	16	150	38	50	52	10	52,5
A100.H18.1	HSK-A 100	18	150	40	50	52	10	52
A100.H20.1	HSK-A 100	20	150	42	50	52	10	51
A100.H25.1	HSK-A 100	25	150	50	50	58	10	-
A100.H32.1	HSK-A 100	32	150	60	60	62	10	-

Lieferumfang: Mit Spannschlüssel
Delivery: With wrench
Livraison: Avec clé de serrage

l₁ = max. Einstecktiefe

l₁ = max. clamping depth

l₁ = max. profondeur d'insertion

l₂ = max. Verstellweg

l₂ = max. length adjustment range

l₂ = max. course de réglage



Verwendung:
Zur Aufnahme von Werkzeugen mit Zylinderschaft nach DIN 1835 Form A+B+E und DIN 6535 Form HB+HE (größer Ø 20 mm nur mit Reduzierung).

Application:
For mounting straight-shank tools acc. DIN 1835 form A+B+E and DIN 6535 form HB+HE (larger than Ø 20 mm only with reduction sleeve).

Application:
Pour le serrage d'outils avec queue cylindrique suivant DIN 1835 forme A+B+E et DIN 6535 forme HB+HE (à partir de Ø 20 mm seulement avec réduction).

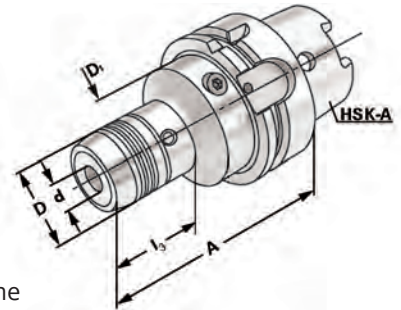

ISO 12164-1 (DIN 69893-1) HSK - A $\lambda \leq 0,003$ G6,3 15.000 min⁻¹



Bestell-Nr. Order no. Référence	HSK	d	A	D	D ₁	l ₁	l ₂	l ₃
A100.H06.2	HSK-A 100	6	200	26	50	37	10	56
A100.H08.2	HSK-A 100	8	200	28	50	37	10	55,5
A100.H10.2	HSK-A 100	10	200	30	50	42	10	55
A100.H12.2	HSK-A 100	12	200	32	50	47	10	54,5
A100.H14.2	HSK-A 100	14	200	34	50	47	10	53
A100.H16.2	HSK-A 100	16	200	38	50	52	10	52,5
A100.H18.2	HSK-A 100	18	200	40	50	52	10	52
A100.H20.2	HSK-A 100	20	200	42	50	52	10	51
A100.H25.2	HSK-A 100	25	200	50	50	58	10	-
A100.H32.2	HSK-A 100	32	200	60	60	62	10	-

Lieferumfang: Mit Spannschlüssel
Delivery: With wrench
Livraison: Avec clé de serrage

l₁ = max. Einstecktiefe
l₁ = max. clamping depth
l₁ = max. profondeur d'insertion

l₂ = max. Verstellweg
l₂ = max. length adjustment range
l₂ = max. course de réglage

Gewuchtete Ausführung



Balanced type
Type équilibré

Bestell-Nr. Order no. Référence	Abmessung Size Dimension
---------------------------------------	--------------------------------

- Wuchten auf G 2,5 von vorgewuchteten Kemmler-Werkzeugen**
Balancing at G 2,5 of pre-balanced Kemmler-tools
Equilibrage sur G 2,5 d'outils Kemmler pré-équilibrés
- W25 **Ohne Wuchtprotokoll**
Without balancing report
Sans protocole d'équilibrage
- W25.2 **Mit Wuchtprotokoll**
With balancing report
Avec protocole d'équilibrage
- Wuchten von nicht vorgewuchteten Werkzeugen**
Balancing of unbalanced tools
Equilibrage d'outils non-équilibrés
- W25.1 **Ohne Wuchtprotokoll**
Without balancing report
Sans protocole d'équilibrage





Shrink chucks 4,5° for mounting of solid carbide and HSS-tool shanks

Mandrins de frettage 4,5° pour le serrage de queues d'outils carbures de type HM et HSS

**Verwendung:**

Zur Aufnahme von Werkzeugen mit Zylinderschaft.

Application:

For mounting straight-shank tools.

Application:

Pour le serrage d'outils avec queue cylindrique.

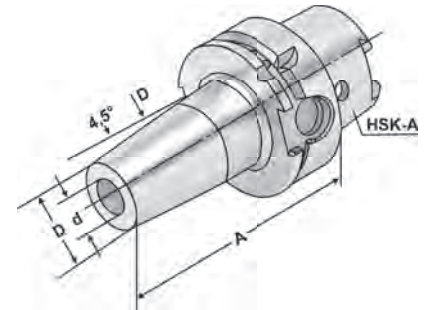
ISO 12164-1
(DIN 69893-1)

HSK - A

 $\lambda \leq 0,003$ G2,5
25.000 min⁻¹

5

Bestell-Nr. Order no. Référence	HSK	d	A	D	D ₁	l ₁	l ₂
A32.70.03	HSK-A 32	3	60	11	15	10	-
A32.70.04	HSK-A 32	4	60	14	15	20	5
A32.70.05	HSK-A 32	5	60	16	15	20	5
A32.70.06	HSK-A 32	6	70	21	27	36	10
A32.70.08	HSK-A 32	8	70	21	27	36	10
A32.70.10	HSK-A 32	10	70	24	29	42	10
A32.70.12	HSK-A 32	12	90	24	29	47	10
A32.70.14	HSK-A 32	14	90	27	34	47	10
A32.70.16	HSK-A 32	16	90	27	34	50	10
A32.70.20	HSK-A 32	20	100	33	40	52	10
A40.70.03	HSK-A 40	3	80	11	15	10	-
A40.70.04	HSK-A 40	4	80	14	22	20	5
A40.70.05	HSK-A 40	5	80	16	22	20	5
A40.70.06	HSK-A 40	6	80	21	27	36	10
A40.70.08	HSK-A 40	8	80	21	27	36	10
A40.70.10	HSK-A 40	10	80	24	32	42	10
A40.70.12	HSK-A 40	12	90	24	32	47	10
A40.70.14	HSK-A 40	14	90	27	34	47	10
A40.70.16	HSK-A 40	16	90	27	34	50	10
A40.70.18	HSK-A 40	18	95	33	42	50	10
A40.70.20	HSK-A 40	20	100	33	42	52	10
A40.70.25	HSK-A 40	25	100	44	51	58	10

Für Ø 3, 4 und 5 mm nur Hartmetallschäfte verwenden!

For Ø 3, 4 and 5 mm only solid carbide tool shanks must be used!

Pour Ø 3, 4 et 5 mm il faut seulement utiliser de queues d'outils carbures de type HM!

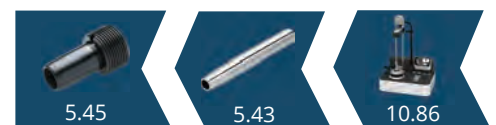
Hinweis: Aufnahme für Induktiv-, Kontakt- und Heißluftschumpfergeräte geeignet. Schafttoleranz bei Ø 3, 4 und 5 mm = h₄, bei Ø 6 - Ø 32 mm = h₆**Note:** Toolholders suitable for induction-, contact- and hot air shrink units. Ø 3, 4, 5 with h₄-tolerance and Ø 6 - Ø 32 with h₆-tolerance**Observation:** Porte-outils convenables pour machines à fretter par induction, par contact, ou par air chaud. Ø 3, 4, 5 avec h₄-tolerance et Ø 6 - Ø 32 avec h₆-tolerancel₁ = max. Einstecktiefel₁ = max. clamping depthl₁ = max. profondeur d'insertionl₂ = max. Verstellwegl₂ = max. length adjustment rangel₂ = max. course de réglage



Shrink chucks 4,5° for mounting of solid carbide and HSS-tool shanks

Mandrins de frettage 4,5° pour le serrage de queues d'outils carbures de type HM et HSS



Verwendung:
Zur Aufnahme von Werkzeugen mit Zylinderschaft.

Application:
For mounting straight-shank tools.

Application:
Pour le serrage d'outils avec queue cylindrique.

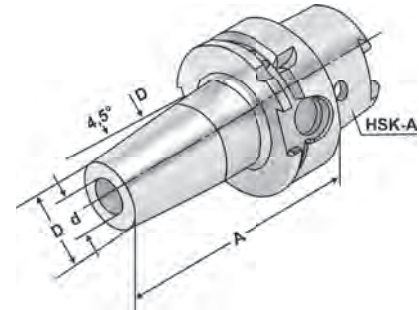

ISO 12164-1
(DIN 69893-1)

HSK - A

$\nabla \leq 0,003$

G2,5
25.000 min⁻¹

Bestell-Nr. Order no. Référence	HSK	d	A	D	D ₁	l ₁	l ₂
A50.70.03	HSK-A 50	3	80	11	15	10	-
A50.70.04	HSK-A 50	4	80	14	22	20	5
A50.70.05	HSK-A 50	5	80	16	22	20	5
A50.70.06	HSK-A 50	6	80	21	27	36	10
A50.70.08	HSK-A 50	8	80	21	27	36	10
A50.70.10	HSK-A 50	10	85	24	32	42	10
A50.70.12	HSK-A 50	12	90	24	32	47	10
A50.70.14	HSK-A 50	14	90	27	34	47	10
A50.70.16	HSK-A 50	16	95	27	34	50	10
A50.70.18	HSK-A 50	18	95	33	42	50	10
A50.70.20	HSK-A 50	20	100	33	42	52	10
A50.70.25	HSK-A 50	25	115	44	53	58	10
A50.70.32	HSK-A 50	32	120	44	53	62	10
A50.70.06.1	HSK-A 50	6	120	21	27	20	10
A50.70.08.1	HSK-A 50	8	120	21	27	20	10
A50.70.10.1	HSK-A 50	10	120	24	32	36	10
A50.70.12.1	HSK-A 50	12	120	24	32	36	10
A50.70.14.1	HSK-A 50	14	120	27	34	41	10
A50.70.16.1	HSK-A 50	16	120	27	34	47	10
A50.70.18.1	HSK-A 50	18	120	33	42	47	10
A50.70.20.1	HSK-A 50	20	120	33	42	50	10
A50.70.03.2	HSK-A 50	3	160	11	15	10	-
A50.70.04.2	HSK-A 50	4	160	14	22	20	5
A50.70.05.2	HSK-A 50	5	160	16	22	20	5
A50.70.06.2	HSK-A 50	6	160	21	27	36	10
A50.70.08.2	HSK-A 50	8	160	21	27	36	10
A50.70.10.2	HSK-A 50	10	160	24	32	41	10
A50.70.12.2	HSK-A 50	12	160	24	32	47	10
A50.70.14.2	HSK-A 50	14	160	27	34	47	10
A50.70.16.2	HSK-A 50	16	160	27	34	50	10
A50.70.18.2	HSK-A 50	18	160	33	42	50	10
A50.70.20.2	HSK-A 50	20	160	33	42	52	10

Hinweis: Aufnahme für Induktiv-, Kontakt- und Heißluftschumpfergeräte geeignet.
Schafttoleranz bei Ø 3, 4 und 5 mm = h₄, bei Ø 6 – Ø 32 mm = h₆

Note: Toolholders suitable for induction-, contact- and hot air shrink units.
Ø 3, 4, 5 with h₄-tolerance and Ø 6 – Ø 32 with h₆-tolerance

Observation: Porte-outils convenables pour machines à fretter par induction,
par contact, ou par air chaud.
Ø 3, 4, 5 avec h₄-tolerance et Ø 6 – Ø 32 avec h₆-tolerance

l₁ = max. Einstecktiefe
l₁ = max. clamping depth
l₁ = max. profondeur d'insertion
l₂ = max. Verstellweg
l₂ = max. length adjustment range
l₂ = max. course de réglage



Shrink chucks 4,5° for mounting of solid carbide and HSS-tool shanks

Mandrins de frettage 4,5° pour le serrage de queues d'outils carbures de type HM et HSS

**Verwendung:**

Zur Aufnahme von Werkzeugen mit Zylinderschaft.

Application:

For mounting straight-shank tools.

Application:

Pour le serrage d'outils avec queue cylindrique.

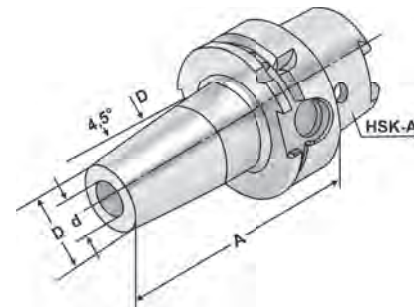
ISO 12164-1
(DIN 69893-1)

HSK - A

 $\lambda \leq 0,003$ G2,5
25.000 min⁻¹

5

Bestell-Nr. Order no. Référence	HSK	d	A	D	D ₁	l ₁	l ₂
A63.70.03	HSK-A 63	3	80	11	15	10	-
A63.70.04	HSK-A 63	4	80	14	22	20	5
A63.70.05	HSK-A 63	5	80	16	22	20	5
A63.70.06	HSK-A 63	6	80	21	27	36	10
A63.70.08	HSK-A 63	8	80	21	27	36	10
A63.70.10	HSK-A 63	10	85	24	32	42	10
A63.70.12	HSK-A 63	12	90	24	32	47	10
A63.70.14	HSK-A 63	14	90	27	34	47	10
A63.70.16	HSK-A 63	16	95	27	34	50	10
A63.70.18	HSK-A 63	18	95	33	42	50	10
A63.70.20	HSK-A 63	20	100	33	42	52	10
A63.70.25	HSK-A 63	25	115	44	53	58	10
A63.70.32	HSK-A 63	32	120	44	53	61	10
A63.70.03.1	HSK-A 63	3	120	11	15	10	-
A63.70.04.1	HSK-A 63	4	120	14	22	20	5
A63.70.05.1	HSK-A 63	5	120	16	22	20	5
A63.70.06.1	HSK-A 63	6	120	21	27	36	10
A63.70.08.1	HSK-A 63	8	120	21	27	36	10
A63.70.10.1	HSK-A 63	10	120	24	32	42	10
A63.70.12.1	HSK-A 63	12	120	24	32	42	10
A63.70.14.1	HSK-A 63	14	120	27	34	47	10
A63.70.16.1	HSK-A 63	16	120	27	34	50	10
A63.70.18.1	HSK-A 63	18	120	33	42	50	10
A63.70.20.1	HSK-A 63	20	120	33	42	52	10
A63.70.25.1	HSK-A 63	25	120	44	53	58	10

Für Ø 3, 4 und 5 mm nur Hartmetallschäfte verwenden!

For Ø 3, 4 and 5 mm only solid carbide tool shanks must be used!

Pour Ø 3, 4 et 5 mm il faut seulement utiliser de queues d'outils carbures de type HM!

Hinweis:Aufnahme für Induktiv-, Kontakt- und Heißluftschumpfergeräte geeignet.
Schafttoleranz bei Ø 3, 4 und 5 mm = h₄, bei Ø 6 – Ø 32 mm = h₆**Note:**Toolholders suitable for induction-, contact- and hot air shrink units.
Ø 3, 4, 5 with h₄-tolerance and Ø 6 – Ø 32 with h₆-tolerance**Observation:**Porte-outils convenables pour machines à fretter par induction,
par contact, ou par air chaud.
Ø 3, 4, 5 avec h₄-tolerance et Ø 6 – Ø 32 avec h₆-tolerancel₁ = max. Einstecktiefel₁ = max. clamping depthl₁ = max. profondeur d'insertionl₂ = max. Verstellwegl₂ = max. length adjustment rangel₂ = max. course de réglage

Shrink chucks 4,5° for mounting of solid carbide and HSS-tool shanks

Mandrins de frettage 4,5° pour le serrage de queues d'outils carbures de type HM et HSS



Verwendung:
Zur Aufnahme von Werkzeugen mit Zylinderschaft.

Application:
For mounting straight-shank tools.

Application:
Pour le serrage d'outils avec queue cylindrique.

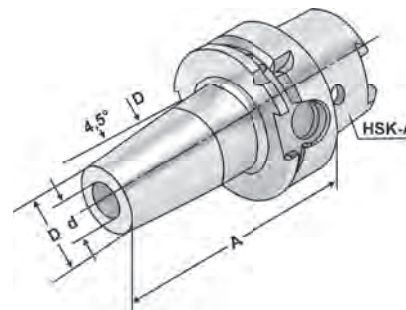

ISO 12164-1
(DIN 69893-1)

HSK - A

$\nabla \leq 0,003$

G2,5
25.000 min⁻¹

Bestell-Nr. Order no. Référence	HSK	d	A	D	D ₁	l ₁	l ₂
A63.70.03.2	HSK-A 63	3	160	11	15	10	-
A63.70.04.2	HSK-A 63	4	160	14	22	20	5
A63.70.05.2	HSK-A 63	5	160	16	22	20	5
A63.70.06.2	HSK-A 63	6	160	21	27	36	10
A63.70.08.2	HSK-A 63	8	160	21	27	36	10
A63.70.10.2	HSK-A 63	10	160	24	32	41	10
A63.70.12.2	HSK-A 63	12	160	24	32	47	10
A63.70.14.2	HSK-A 63	14	160	27	34	47	10
A63.70.16.2	HSK-A 63	16	160	27	34	50	10
A63.70.18.2	HSK-A 63	18	160	33	42	50	10
A63.70.20.2	HSK-A 63	20	160	33	42	52	10
A63.70.25.2	HSK-A 63	25	160	44	53	58	10
A63.70.32.2	HSK-A 63	32	160	44	53	62	10
A63.70.06.3	HSK-A 63	6	200	21	27	36	10
A63.70.08.3	HSK-A 63	8	200	21	27	36	10
A63.70.10.3	HSK-A 63	10	200	24	32	41	10
A63.70.12.3	HSK-A 63	12	200	24	32	47	10
A63.70.16.3	HSK-A 63	16	200	27	34	50	10
A63.70.20.3	HSK-A 63	20	200	33	42	52	10
A63.70.25.3	HSK-A 63	25	200	44	53	58	
A63.70.32.3	HSK-A 63	32	200	44	53	62	10

Für Ø 3, 4 und 5 mm nur Hartmetallschäfte verwenden!

For Ø 3, 4 and 5 mm only solid carbide tool shanks must be used!

Pour Ø 3, 4 et 5 mm il faut seulement utiliser de queues d'outils carbures de type HM!

Hinweis: Aufnahme für Induktiv-, Kontakt- und Heißluftschumpfergeräte geeignet.
Schafttoleranz bei Ø 3, 4 und 5 mm = h₄, bei Ø 6 – Ø 32 mm = h₆

Note: *Toolholders suitable for induction-, contact- and hot air shrink units.
Ø 3, 4, 5 with h₄-tolerance and Ø 6 – Ø 32 with h₆-tolerance*

Observation: Porte-outils convenables pour machines à fretter par induction, par contact, ou par air chaud.
Ø 3, 4, 5 avec h₄-tolerance et Ø 6 – Ø 32 avec h₆-tolerance

l₁ = max. Einstecktiefe

l₁ = max. clamping depth

l₁ = max. profondeur d'insertion

l₂ = max. Verstellweg

l₂ = max. length adjustment range

l₂ = max. course de réglage





Shrink chucks 4,5° for mounting of solid carbide and HSS-tool shanks

Mandrins de frettage 4,5° pour le serrage de queues d'outils carbures de type HM et HSS

**Verwendung:**

Zur Aufnahme von Werkzeugen mit Zylinderschaft.

Application:

For mounting straight-shank tools.

Application:

Pour le serrage d'outils avec queue cylindrique.

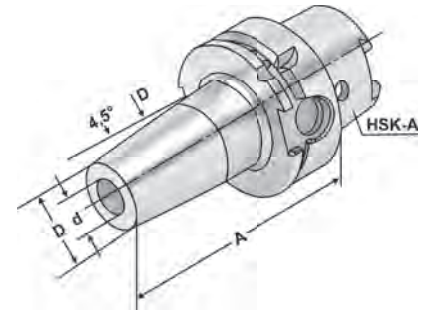
ISO 12164-1
(DIN 69893-1)

HSK - A

 $\lambda \leq 0,003$ G2,5
25.000 min⁻¹

5

Bestell-Nr. Order no. Référence	HSK	d	A	D	D ₁	l ₁	l ₂
A80.70.04	HSK-A 80	4	80	14	22	20	5
A80.70.06	HSK-A 80	6	85	21	27	36	10
A80.70.08	HSK-A 80	8	85	21	27	36	10
A80.70.10	HSK-A 80	10	90	24	32	42	10
A80.70.12	HSK-A 80	12	95	24	32	47	10
A80.70.14	HSK-A 80	14	95	27	34	47	10
A80.70.16	HSK-A 80	16	100	27	34	50	10
A80.70.18	HSK-A 80	18	100	33	42	50	10
A80.70.20	HSK-A 80	20	105	33	42	52	10
A80.70.25	HSK-A 80	25	115	44	53	58	10
A80.70.32	HSK-A 80	32	120	44	53	61	10
A80.70.06.1	HSK-A 80	6	120	21	27	36	10
A80.70.08.1	HSK-A 80	8	120	21	27	36	10
A80.70.10.1	HSK-A 80	10	120	24	32	41	10
A80.70.12.1	HSK-A 80	12	120	24	32	47	10
A80.70.14.1	HSK-A 80	14	120	27	34	47	10
A80.70.06.2	HSK-A 80	6	160	21	27	36	10
A80.70.08.2	HSK-A 80	8	160	21	27	36	10
A80.70.10.2	HSK-A 80	10	160	24	32	41	10
A80.70.12.2	HSK-A 80	12	160	24	32	47	10
A80.70.14.2	HSK-A 80	14	160	27	34	47	10
A80.70.16.2	HSK-A 80	16	160	27	34	50	10
A80.70.18.2	HSK-A 80	18	160	33	42	50	10
A80.70.20.2	HSK-A 80	20	160	33	42	52	10
A80.70.25.2	HSK-A 80	25	160	44	53	58	10

Für Ø 3, 4 und 5 mm nur Hartmetallschäfte verwenden!

For Ø 3, 4 and 5 mm only solid carbide tool shanks must be used!

Pour Ø 3, 4 et 5 mm il faut seulement utiliser de queues d'outils carbures de type HM!

Hinweis: Aufnahme für Induktiv-, Kontakt- und Heißluftschumpfgeräte geeignet.
Schafttoleranz bei Ø 3, 4 und 5 mm = h₄, bei Ø 6 – Ø 32 mm = h₆**Note:** Toolholders suitable for induction-, contact- and hot air shrink units.
Ø 3, 4, 5 with h₄-tolerance and Ø 6 – Ø 32 with h₆-tolerance**Observation:** Porte-outils convenables pour machines à fretter par induction,
par contact, ou par air chaud.
Ø 3, 4, 5 avec h₄-tolerance et Ø 6 – Ø 32 avec h₆-tolerancel₁ = max. Einstecktiefel₁ = max. clamping depthl₁ = max. profondeur d'insertionl₂ = max. Verstellwegl₂ = max. length adjustment rangel₂ = max. course de réglage

Shrink chucks 4,5° for mounting of solid carbide and HSS-tool shanks

Mandrins de frettage 4,5° pour le serrage de queues d'outils carbures de type HM et HSS



Verwendung:
Zur Aufnahme von Werkzeugen mit
Zylinderschaft.

Application:
For mounting straight-shank tools.

Application:
Pour le serrage d'outils avec queue
cylindrique.

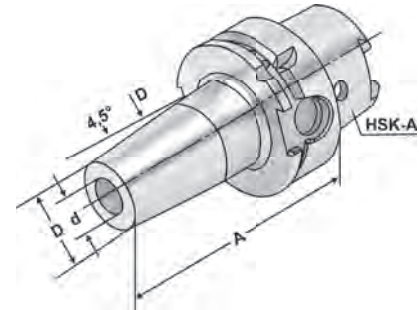

ISO 12164-1
(DIN 69893-1)

HSK - A

$\nabla \leq 0,003$

G2,5
25.000 min⁻¹

Bestell-Nr. Order no. Référence	HSK	d	A	D	D ₁	l ₁	l ₂
A100.70.04	HSK-A 100	4	85	14	22	20	5
A100.70.05	HSK-A 100	5	85	16	22	20	5
A100.70.06	HSK-A 100	6	85	21	27	36	10
A100.70.08	HSK-A 100	8	85	21	27	36	10
A100.70.10	HSK-A 100	10	90	24	32	42	10
A100.70.12	HSK-A 100	12	95	24	32	47	10
A100.70.14	HSK-A 100	14	95	27	34	47	10
A100.70.16	HSK-A 100	16	100	27	34	50	10
A100.70.18	HSK-A 100	18	100	33	42	50	10
A100.70.20	HSK-A 100	20	105	33	42	52	10
A100.70.25	HSK-A 100	25	120	44	53	56	10
A100.70.32	HSK-A 100	32	120	44	53	62	10
A100.70.40	HSK-A 100	40	150	78	90	90	10
A100.70.50	HSK-A 100	50	150	78	90	90	10
A100.70.06.1	HSK-A 100	6	120	21	27	36	10
A100.70.08.1	HSK-A 100	8	120	21	27	36	10
A100.70.10.1	HSK-A 100	10	120	24	32	41	10
A100.70.12.1	HSK-A 100	12	120	24	32	47	10
A100.70.14.1	HSK-A 100	14	120	27	34	47	10
A100.70.16.1	HSK-A 100	16	120	27	34	50	10
A100.70.18.1	HSK-A 100	18	120	33	42	50	10
A100.70.20.1	HSK-A 100	20	120	33	42	52	10
A100.70.06.2	HSK-A 100	6	160	21	27	36	10
A100.70.08.2	HSK-A 100	8	160	21	27	36	10
A100.70.10.2	HSK-A 100	10	160	24	32	41	10
A100.70.12.2	HSK-A 100	12	160	24	32	47	10
A100.70.14.2	HSK-A 100	14	160	27	34	47	10
A100.70.16.2	HSK-A 100	16	160	27	34	50	10
A100.70.18.2	HSK-A 100	18	160	33	42	50	10
A100.70.20.2	HSK-A 100	20	160	33	42	52	10
A100.70.25.2	HSK-A 100	25	160	44	53	58	10
A100.70.32.2	HSK-A 100	32	160	44	53	62	10

Hinweis: Aufnahme für Induktiv-, Kontakt- und Heißluftschumpfgeräte geeignet. Schafttoleranz bei Ø 3, 4 und 5 mm = h₄, bei Ø 6 - Ø 32 mm = h₆

Note: Toolholders suitable for induction-, contact- and hot air shrink units. Ø 3, 4, 5 with h₄-tolerance and Ø 6 - Ø 32 with h₆-tolerance

Observation: Porte-outils convenables pour machines à fretter par induction, par contact, ou par air chaud. Ø 3, 4, 5 avec h₄-tolerance et Ø 6 - Ø 32 avec h₆-tolerance

l₁ = max. Einstecktiefe

l₁ = max. clamping depth

l₁ = max. profondeur d'insertion

l₂ = max. Verstellweg

l₂ = max. length adjustment range

l₂ = max. course de réglage



Shrink chucks 4,5° for mounting of solid carbide and HSS-tool shanks

Mandrins de frettage 4,5° pour le serrage de queues d'outils carbures de type HM et HSS

**Verwendung:**

Zur Aufnahme von Werkzeugen mit Zylinderschaft.

Application:

For mounting straight-shank tools.

Application:

Pour le serrage d'outils avec queue cylindrique.

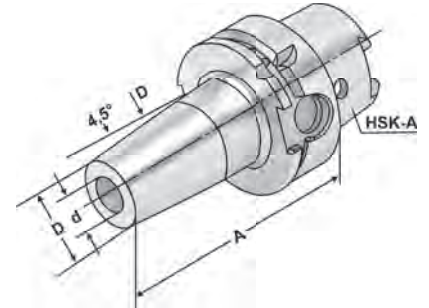
ISO 12164-1
(DIN 69893-1)

HSK - A

 $\lambda \leq 0,003$ G2,5
25.000 min⁻¹

5

Bestell-Nr. Order no. Référence	HSK	d	A	D	D ₁	l ₁	l ₂
A100.70.06.3	HSK-A 100	6	200	21	27	36	10
A100.70.08.3	HSK-A 100	8	200	21	27	36	10
A100.70.10.3	HSK-A 100	10	200	24	32	41	10
A100.70.12.3	HSK-A 100	12	200	24	32	47	10
A100.70.14.3	HSK-A 100	14	200	27	34	47	10
A100.70.16.3	HSK-A 100	16	200	27	34	50	10
A100.70.18.3	HSK-A 100	18	200	33	42	50	10
A100.70.20.3	HSK-A 100	20	200	33	42	52	10
A100.70.25.3	HSK-A 100	25	200	44	53	58	10
A100.70.32.3	HSK-A 100	32	200	44	53	62	10
A100.70.06.4	HSK-A 100	6	250	21	27	36	10
A100.70.08.4	HSK-A 100	8	250	21	27	36	10
A100.70.10.4	HSK-A 100	10	250	24	32	41	10
A100.70.12.4	HSK-A 100	12	250	24	32	47	10
A100.70.14.4	HSK-A 100	14	250	27	34	47	10
A100.70.16.4	HSK-A 100	16	250	27	34	50	10

Hinweis: Aufnahme für Induktiv-, Kontakt- und Heißluftschumpfgeräte geeignet.
Schafttoleranz bei Ø 3, 4 und 5 mm = h₄, bei Ø 6 – Ø 32 mm = h₆

Note: Toolholders suitable for induction-, contact- and hot air shrink units.
Ø 3, 4, 5 with h₄-tolerance and Ø 6 – Ø 32 with h₆-tolerance

Observation: Porte-outils convenables pour machines à fretter par induction,
par contact, ou par air chaud.
Ø 3, 4, 5 avec h₄-tolerance et Ø 6 – Ø 32 avec h₆-tolerance

l₁ = max. Einstecktiefel₁ = max. clamping depthl₁ = max. profondeur d'insertionl₂ = max. Verstellwegl₂ = max. length adjustment rangel₂ = max. course de réglage

Shrink chucks 4,5° for mounting of solid carbide and HSS-tool shanks

Mandrins de frettage 4,5° pour le serrage de queues d'outils carbures de type HM et HSS



Verwendung:
Zur Aufnahme von Werkzeugen mit Zylinderschaft.

Application:
For mounting straight-shank tools.

Application:
Pour le serrage d'outils avec queue cylindrique.

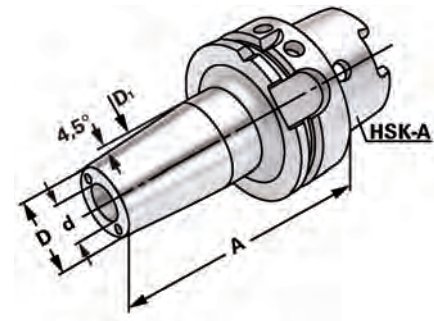

ISO 12164-1
(DIN 69893-1)

HSK - A

$\lambda \leq 0,003$

G2,5
25.000 min⁻¹

Bestell-Nr. Order no. Référence	HSK	d	A	D	D ₁	l ₁	l ₂
A63.70.03.K	HSK-A 63	3	80	11	15	10	-
A63.70.04.K	HSK-A 63	4	80	14	22	20	5
A63.70.05.K	HSK-A 63	5	80	16	22	20	5
A63.70.06.K	HSK-A 63	6	80	21	27	36	10
A63.70.08.K	HSK-A 63	8	80	21	27	36	10
A63.70.10.K	HSK-A 63	10	85	24	32	42	10
A63.70.12.K	HSK-A 63	12	90	24	32	47	10
A63.70.14.K	HSK-A 63	14	90	27	34	47	10
A63.70.16.K	HSK-A 63	16	95	27	34	50	10
A63.70.18.K	HSK-A 63	18	95	33	42	50	10
A63.70.20.K	HSK-A 63	20	100	33	42	52	10
A63.70.25.K	HSK-A 63	25	115	44	53	58	10
A63.70.32.K	HSK-A 63	32	120	44	53	61	10
A63.70.03.1.K	HSK-A 63	3	120	11	15	10	-
A63.70.04.1.K	HSK-A 63	4	120	14	22	20	5
A63.70.05.1.K	HSK-A 63	5	120	16	22	20	5
A63.70.06.1.K	HSK-A 63	6	120	21	27	36	10
A63.70.08.1.K	HSK-A 63	8	120	21	27	36	10
A63.70.10.1.K	HSK-A 63	10	120	24	32	42	10
A63.70.12.1.K	HSK-A 63	12	120	24	32	47	10
A63.70.14.1.K	HSK-A 63	14	120	27	34	47	10
A63.70.16.1.K	HSK-A 63	16	120	27	34	50	10
A63.70.18.1.K	HSK-A 63	18	120	33	42	50	10
A63.70.20.1.K	HSK-A 63	20	120	33	42	52	10
A63.70.25.1.K	HSK-A 63	25	120	44	53	58	10

5

Für Ø 3, 4 und 5 mm nur Hartmetallschäfte verwenden!

For Ø 3, 4 and 5 mm only solid carbide tool shanks must be used!

Pour Ø 3, 4 et 5 mm il faut seulement utiliser de queues d'outils carbures de type HM!

Hinweis: Aufnahme für Induktiv-, Kontakt- und Heißluftschumpfgeräte geeignet.
Schafttoleranz bei Ø 3, 4 und 5 mm = h₄, bei Ø 6 – Ø 32 mm = h₆

Note: Toolholders suitable for induction-, contact- and hot air shrink units.
Ø 3, 4, 5 with h₄-tolerance and Ø 6 – Ø 32 with h₆-tolerance

Observation: Porte-outils convenables pour machines à fretter par induction, par contact, ou par air chaud.
Ø 3, 4, 5 avec h₄-tolerance et Ø 6 – Ø 32 avec h₆-tolerance

l₁ = max. Einstecktiefe

l₁ = max. clamping depth

l₁ = max. profondeur d'insertion

l₂ = max. Verstellweg

l₂ = max. length adjustment range

l₂ = max. course de réglage



Schrumpffutter 4,5° mit Kühlkanälen zum Spannen von HM und HSS Werkzeugschäften

ISO 12164 (HSK-A)

DIN 69893 (HSK-A)

Shrink chucks 4,5° for mounting of solid carbide and HSS-tool shanks
Mandrins de frettage 4,5° pour le serrage de queues d'outils carbures de type HM et HSS



Verwendung:
Zur Aufnahme von Werkzeugen mit Zylinderschaft.

Application:
For mounting straight-shank tools.

Application:
Pour le serrage d'outils avec queue cylindrique.

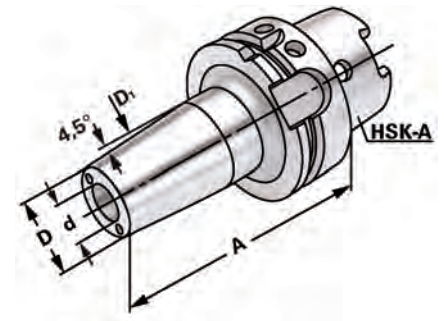

ISO 12164-1
(DIN 69893-1)

HSK - A

$\nabla \leq 0,003$

G2,5
25.000 min⁻¹

5

Bestell-Nr. Order no. Référence	HSK	d	A	D	D ₁	l ₁	l ₂
A63.70.06.2.K	HSK-A 63	6	160	21	27	36	10
A63.70.08.2.K	HSK-A 63	8	160	21	27	36	10
A63.70.10.2.K	HSK-A 63	10	160	24	32	42	10
A63.70.12.2.K	HSK-A 63	12	160	24	32	47	10
A63.70.14.2.K	HSK-A 63	14	160	27	34	47	10
A63.70.16.2.K	HSK-A 63	16	160	27	34	50	10
A63.70.18.2.K	HSK-A 63	18	160	33	42	50	10
A63.70.20.2.K	HSK-A 63	20	160	33	42	52	10
A63.70.25.2.K	HSK-A 63	25	160	44	53	58	10
A63.70.32.2.K	HSK-A 63	32	160	44	53	61	10
A100.70.05.K	HSK-A 100	5	80	16	22	20	5
A100.70.06.K	HSK-A 100	6	80	21	27	36	10
A100.70.08.K	HSK-A 100	8	80	21	27	36	10
A100.70.10.K	HSK-A 100	10	85	24	32	42	10
A100.70.12.K	HSK-A 100	12	90	24	32	47	10
A100.70.14.K	HSK-A 100	14	90	27	34	47	10
A100.70.16.K	HSK-A 100	16	95	27	34	50	10
A100.70.18.K	HSK-A 100	18	95	33	42	50	10
A100.70.20.K	HSK-A 100	20	100	33	42	52	10
A100.70.25.K	HSK-A 100	25	115	44	53	58	10
A100.70.32.K	HSK-A 100	32	120	44	53	61	10
A100.70.05.1.K	HSK-A 100	5	120	16	22	20	5
A100.70.06.1.K	HSK-A 100	6	120	21	27	36	10
A100.70.08.1.K	HSK-A 100	8	120	21	27	36	10
A100.70.10.1.K	HSK-A 100	10	120	24	32	42	10
A100.70.12.1.K	HSK-A 100	12	120	24	32	47	10
A100.70.14.1.K	HSK-A 100	14	120	27	34	47	10
A100.70.16.1.K	HSK-A 100	16	120	27	34	50	10
A100.70.18.1.K	HSK-A 100	18	120	33	42	50	10
A100.70.20.1.K	HSK-A 100	20	120	33	42	52	10
A100.70.25.1.K	HSK-A 100	25	120	44	53	58	10
A100.70.32.1.K	HSK-A 100	32	120	44	53	61	10

Hinweis: Aufnahme für Induktiv-, Kontakt- und Heißluftschumpfergeräte geeignet.
Schafttoleranz bei Ø 3, 4 und 5 mm = h₄, bei Ø 6 – Ø 32 mm = h₆

Note: Toolholders suitable for induction-, contact- and hot air shrink units.
Ø 3, 4, 5 with h₄-tolerance and Ø 6 – Ø 32 with h₆-tolerance

Observation: Porte-outils convenables pour machines à fretter par induction,
par contact, ou par air chaud.
Ø 3, 4, 5 avec h₄-tolerance et Ø 6 – Ø 32 avec h₆-tolerance

l₁ = max. Einstecktiefe
l₁ = max. clamping depth
l₁ = max. profondeur d'insertion
l₂ = max. Verstellweg
l₂ = max. length adjustment range
l₂ = max. course de réglage

Shrink chucks 3° for mounting of solid carbide and HSS-tool shanks - slim

Mandrins de frettage 3° pour le serrage de queues d'outils carbures de type HM et HSS - élané



Verwendung:
Zur Aufnahme von Werkzeugen mit Zylinderschaft.

Application:
For mounting straight-shank tools.

Application:
Pour le serrage d'outils avec queue cylindrique.

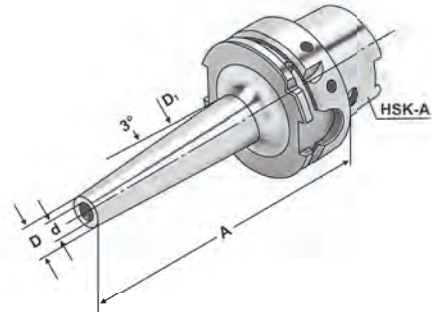

ISO 12164-1
(DIN 69893-1)

HSK - A

$\lambda \leq 0,003$

G2,5
25.000 min⁻¹

Bestell-Nr. Order no. Référence	HSK	d	A	D	D ₁	l ₁	l ₂
A63.72.03	HSK-A 63	3	80	9	15,5	6	-
A63.72.03.1	HSK-A 63	3	120	9	19,5	6	-
A63.72.04	HSK-A 63	4	80	10	16,5	8	-
A63.72.04.1	HSK-A 63	4	120	10	20,5	8	-
A63.72.05	HSK-A 63	5	80	11	17,5	10	-
A63.72.05.1	HSK-A 63	5	120	11	21,5	10	-
A63.72.06	HSK-A 63	6	80	12	18,5	36	10
A63.72.06.1	HSK-A 63	6	120	12	22,5	36	10
A63.72.06.2	HSK-A 63	6	160	12	26,5	36	10
A63.72.08	HSK-A 63	8	80	14	20,5	36	10
A63.72.08.1	HSK-A 63	8	120	14	24,5	36	10
A63.72.08.2	HSK-A 63	8	160	14	28,5	36	10
A63.72.10	HSK-A 63	10	80	16	22,5	42	10
A63.72.10.1	HSK-A 63	10	120	16	26,5	42	10
A63.72.10.2	HSK-A 63	10	160	16	30,5	42	10
A63.72.12	HSK-A 63	12	80	18	24,5	47	10
A63.72.12.1	HSK-A 63	12	120	18	28,5	47	10
A63.72.12.2	HSK-A 63	12	160	18	32,5	47	10

Ausführung: schlanke Bauform (reduzierte Störkontur)
Version: slim design (reduced interference contour)
Version: Modèle très étroit (encombrement réduit)

Für Ø 3, 4 und 5 mm nur Hartmetallschäfte verwenden!
For Ø 3, 4 and 5 mm only solid carbide tool shanks must be used!
Pour Ø 3, 4 et 5 mm il faut seulement utiliser de queues d'outils carbures de type HM!

Hinweis: Aufnahmen für Induktiv-, Kontakt- und Heißluftschumpfgeräte geeignet.
Schafttoleranz bei Ø 3, 4 und 5 mm = h₄, bei Ø 6 - Ø 32 mm = h₆

Note: Toolholders suitable for induction-, contact- and hot air shrink units.
Ø 3, 4, 5 with h₄-tolerance and Ø 6 - Ø 32 with h₆-tolerance

Observation: Porte-outils convenables pour machines à fretter par induction, par contact, ou par air chaud.
Ø 3, 4, 5 avec h₄-tolerance et Ø 6 - Ø 32 avec h₆-tolerance

l₁ = max. Einstecktiefe
l₁ = max. clamping depth
l₁ = max. profondeur d'insertion

l₂ = max. Verstellweg
l₂ = max. length adjustment range
l₂ = max. course de réglage





Verwendung:
Zur Aufnahme von Werkzeugen mit Zylinderschaft.

Application:
For mounting straight-shank tools.

Application:
Pour le serrage d'outils avec queue cylindrique.

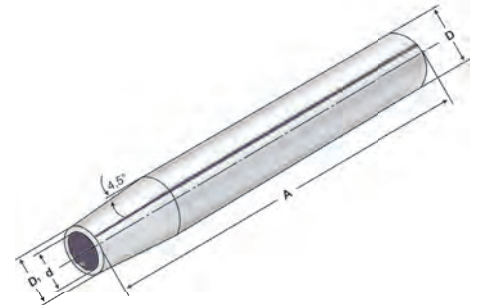

5

Bestell-Nr. Order no. Référence	D	d	D ₁	A	l ₁	l ₂
120.70.03	20	3	10	150	15	5
120.70.04	20	4	10	150	20	5
120.70.05	20	5	10	150	20	5
120.70.06*	20	6	10	150	36	10
120.70.08*	20	8	12	150	36	10
120.70.10*	20	10	14	150	42	10
120.70.12*	20	12	16	150	47	10

* mit Anschlag | * with end stop | * avec butée

Für Ø 3, 4 und 5 mm nur Hartmetallschäfte verwenden!

For Ø 3, 4 and 5 mm only solid carbide tool shanks must be used!

Pour Ø 3, 4 et 5 mm il faut seulement utiliser de queues d'outils carbures de type HM!

Hinweis: Aufnahmen für Induktiv-, Kontakt- und Heißluftschumpfgeräte geeignet.
Schafttoleranz bei Ø 3, 4 und 5 mm = h₄, bei Ø 6 – Ø 32 mm = h₆

Note: Toolholders suitable for induction-, contact- and hot air shrink units.
Ø 3, 4, 5 with h₄-tolerance and Ø 6 – Ø 32 with h₆-tolerance

Observation: Porte-outils convenables pour machines à fretter par induction, par contact, ou par air chaud.
Ø 3, 4, 5 avec h₄-tolerance et Ø 6 – Ø 32 avec h₆-tolerance

l₁ = max. Einstecktiefe
l₁ = max. clamping depth
l₁ = max. profondeur d'insertion

l₂ = max. Verstellweg
l₂ = max. length adjustment range
l₂ = max. course de réglage





Test arbors
Mandrins de contrôle

DIN 69893 (HSK-A)



Verwendung:
Zur Abnahme von Werkzeugmaschinen gemäß ISO-Empfehlung R230 oder zur Überprüfung der Werkzeugspindel.

Application:
For the inspection of machine tools according to ISO recommendation R230 or for testing the tool spindle.

Application:
Pour l'inspection de machine-outils suite à la recommandation ISO R230 ou pour la vérification de la broche.

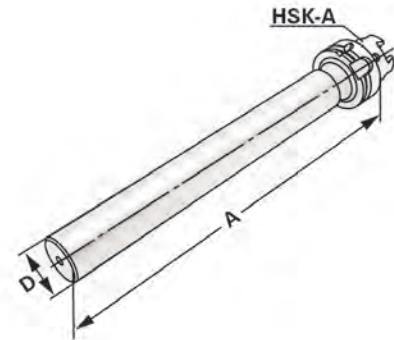

ISO 12164-1 (DIN 69893-1)	HSK - A	$\nearrow \leq 0,003$
------------------------------	---------	-----------------------

Bestell-Nr. Order no. Référence	HSK	D	A	Toleranz Tolerance Tolérance	max. Rundlaufabweichung max. concentricity deviation Faux-rond max.
A32.18.25	HSK-A 32	25	200	0,003	0,003
A40.18.25	HSK-A 40	25	200	0,003	0,003
A50.18.32	HSK-A 50	32	346	0,003	0,003
A63.18.40	HSK-A 63	40	346	0,003	0,003
A80.18.50	HSK-A 80	40	346	0,003	0,003
A100.18.50	HSK-A 100	50	329	0,003	0,003



Lieferumfang: Auslieferung mit Prüfprotokoll
Delivery: Delivery with test certificate
Livraison: Livraison avec rapport d essais

Holzkasten für Kontrolldorne

Wooden box for test arbors
Coffret en bois pour mandrins de contrôle



Verwendung:
Zur Aufbewahrung von Kontrolldornen.

Application:
For the storage of test arbors.

Application:
Pour la conservation de mandrins de contrôle.



Bestell-Nr. Order no. Référence	Abmessung Size Dimension	für Kegelgrößen for cones pour cônes
701.18	460 × 130 × 115	HSK 32 / 40 / 50 / 63 / 80 / 100



Verwendung:
Zur zentralen Übergabe von Kühlmittel bei HSK-Werkzeugaufnahmen.

Application:
For the coolant supply through the centre of HSK toolholders.

Application:
Pour l'arrosage centrale de porte-outils HSK.

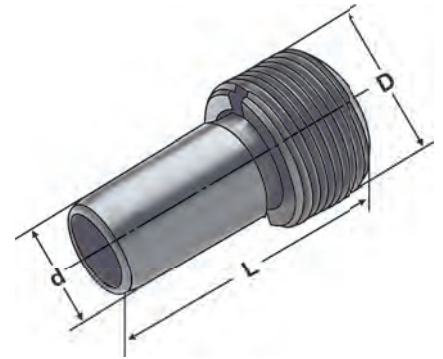

ISO 12164-1
(DIN 69893-1)

HSK - A

5

Bestell-Nr. Order no. Référence	HSK	D	d	L
A32.700	HSK 32	M10 × 1	6	26,0
A40.700	HSK 40	M12 × 1	8	29,5
A50.700	HSK 50	M16 × 1	10	33,0
A63.700	HSK 63	M18 × 1	12	34,5
A80.700	HSK 80	M20 × 1,5	14	40,0
A100.700	HSK 100	M24 × 1,5	16	44,0

Hinweis: Axial abgedichtet mit zwei O-Ringen.
Die Kühlmittelübergabeeinheit ist nach dem Einbau, gemäß DIN, minimal beweglich ($\pm 1^\circ$).

Note: *Axial sealed with two O-rings.*
After mounting, the coolant tube can be moved only to a minimum degree according to DIN ($\pm 1^\circ$).

Observation: Etanche axiale avec deux joints toriques.
Après le montage, la canule de lubrification peut être déplacée légèrement suivant DIN ($\pm 1^\circ$).

Key for coolant tubes
Clés pour canules de lubrification

DIN 69893 (HSK-A)



Verwendung:
Zum Montieren der Kühlmittelübergabeeinheiten in HSK-Werkzeugaufnahmen.

Application:
For mounting the coolant tubes in HSK toolholders.

Application:
Pour le montage de canules de lubrification dans des porte-outils HSK.

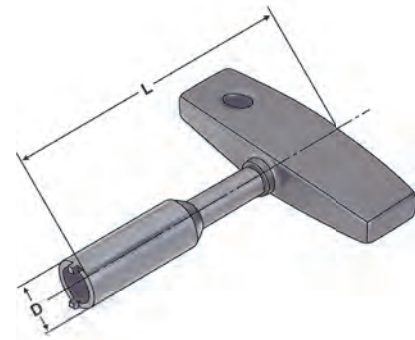

ISO 12164-1
(DIN 69893-1)

HSK - A

Bestell-Nr. Order no. Référence	HSK	D	L
A32.701	HSK 32	8,5	115
A40.701	HSK 40	10,5	115
A50.701	HSK 50	14,5	115
A63.701	HSK 63	16,5	136
A80.701	HSK 80	18,5	136
A100.701	HSK 100	22,0	136



Vorgewuchtet
Pre-balanced
Pré-équilibré

G 6,3 15.000 min⁻¹

G 2,5 Feinwuchten gegen Aufpreis
G 2.5 Fine balancing at extra charge
G 2,5 Equilibrage fin contre un supplément

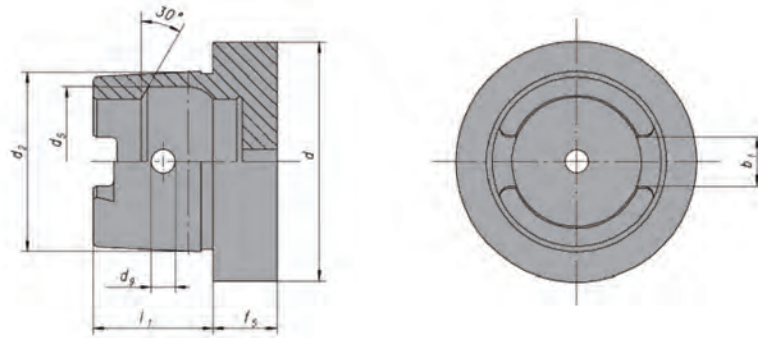

5

d ₁	l ₁	f ₅	d ₂	d ₅	d ₉	b ₁
32	16	10	24	21	4	7,05
40	20	10	30	25,5	4,6	8,05
50	25	12,5	38	32	6	10,54
63	32	12,5	48	40	7,5	12,54
80	40	16	60	50	8,5	16,04
100	50	16	75	63	12	20,02

Werkstoff: Legierter Einsatzstahl mit einer Zugfestigkeit im Kern von min. 1200 N / mm². Einsatzgehärtet HRC 60 ± 2 (HV 700 ± 50), Härtetiefe 0,8 mm ± 0,2 mm, brüniert und präzisionsgeschliffen.

Genauigkeit: Kegelwinkel – Toleranzqualität < AT 3 nach DIN 7187.

Material: Alloyed case-hardened steel, tensile core strength of min. 1200 N / mm². Case hardened HRC 60 ± 2 (HV 700 ± 50), hardening depth 0.8 mm ± 0.2 mm, black-finished and precisely grinded.

Accuracy: Quality of taper < AT 3 according to DIN 7187.

Matière: Acier de cémentation allié. Résistance à la traction dans le noyau de min 1200 N / mm². Cémentation à HRC 60 ± 2 (HV 700 ± 50), profondeur de cémentation 0,8 mm ± 0,2 mm, bruni et rectifié précisément.

Précision: Qualité du cône < AT 3 suivant DIN 7187.



**Verwendung:**

Zur Aufnahme von Werkzeugen mit Zylinderschaft in Spannzangen.

Application:

For mounting straight-shank tools in collets.

Application:

Pour le serrage d'outils avec queue cylindrique dans des pinces de serrage.

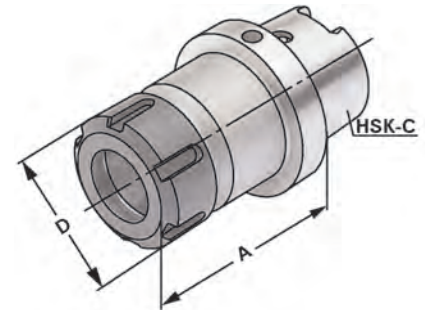
ISO 12164-1
(DIN 69893-1)

HSK - C

 $\nabla \leq 0,003$ G6,3
15.000 min⁻¹

5

Bestell-Nr. Order no. Référence	HSK	Spannbereich Capacity Capacité	A	D
C25.02.07.M	HSK-C 25	1 – 6 (ER 11) Mini	40	16
C25.02.10.M	HSK-C 25	1 – 10 (ER 16) Mini	55	22
C32.02.10	HSK-C 32	1 – 10 (ER 16)	60	28
C40.02.10.M	HSK-C 40	1 – 10 (ER 16) Mini	70	22
C40.02.10	HSK-C 40	1 – 10 (ER 16)	60	28
C40.02.16	HSK-C 40	2 – 16 (ER 25)	70	42
C40.02.20	HSK-C 40	2 – 20 (ER 32)	75	50
C40.02.26	HSK-C 40	3 – 26 (ER 40)	85	63
C50.02.10	HSK-C 50	1 – 10 (ER 16)	60	28
C50.02.16	HSK-C 50	2 – 16 (ER 25)	70	42
C50.02.20	HSK-C 50	2 – 20 (ER 32)	80	50
C50.02.26	HSK-C 50	3 – 26 (ER 40)	80	63
C50.02.10.1	HSK-C 50	1 – 10 (ER 16)	100	28
C63.02.10	HSK-C 63	1 – 10 (ER 16)	60	28
C63.02.16	HSK-C 63	2 – 16 (ER 25)	70	42
C63.02.20	HSK-C 63	2 – 20 (ER 32)	75	50
C63.02.26	HSK-C 63	3 – 26 (ER 40)	80	63
C63.02.10.1	HSK-C 63	1 – 10 (ER 16)	100	28
C80.02.10	HSK-C 80	1 – 10 (ER 16)	100	28
C80.02.20	HSK-C 80	2 – 20 (ER 32)	80	50
C80.02.26	HSK-C 80	3 – 26 (ER 40)	85	63
C80.02.10.1	HSK-C 80	1 – 10 (ER 16)	160	28
C100.02.10	HSK-C 100	1 – 10 (ER 16)	100	28
C100.02.20	HSK-C 100	2 – 20 (ER 32)	80	50
C100.02.26	HSK-C 100	3 – 26 (ER 40)	90	63
C100.02.10.1	HSK-C 100	1 – 10 (ER 16)	160	28

Lieferumfang:Delivery:
Livraison:Mit gewuchteter Spannmutter
With balanced clamping nut
Avec écrou de serrage équilibré

End mill holders DIN 6359 for end mills DIN 1835-B

Porte-fraises DIN 6359 pour queues cylindriques DIN 1835-B

DIN 69893 (HSK-C)

**Verwendung:**

Zum Spannen von zylindrischen
Werkzeugschäften mit seitlicher Spann-
fläche nach DIN 1835 Form B (Weldon).

Application:

For mounting straight-shank tools with flat
according to DIN 1835 form B (Weldon).

Application:

Pour le serrage d'outils avec queue
cylindrique et avec méplat suivant DIN
1835 forme B (Weldon).

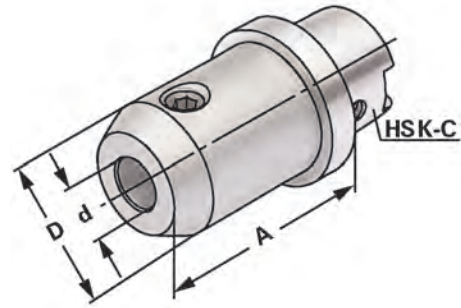
ISO 12164-1
(DIN 69893-1)

HSK - C

 $\nabla \leq 0,003$ G6,3
15.000 min⁻¹

14.04

Bestell-Nr.
Order no.
Référence

HSK

d^{H4}

A

D

C40.04.08	HSK-C 40	8	60	28
C40.04.10	HSK-C 40	10	70	35
C40.04.12	HSK-C 40	12	70	42
C40.04.14	HSK-C 40	14	75	44
C40.04.16	HSK-C 40	16	75	48
C40.04.18	HSK-C 40	18	80	50
C40.04.20	HSK-C 40	20	80	52
C50.04.06	HSK-C 50	6	60	25
C50.04.08	HSK-C 50	8	60	28
C50.04.10	HSK-C 50	10	65	35
C50.04.12	HSK-C 50	12	75	42
C50.04.14	HSK-C 50	14	75	44
C50.04.16	HSK-C 50	16	80	48
C50.04.18	HSK-C 50	18	80	50
C50.04.20	HSK-C 50	20	80	50
C50.04.25	HSK-C 50	25	80	50
C63.04.06	HSK-C 63	6	60	25
C63.04.08	HSK-C 63	8	60	28
C63.04.10	HSK-C 63	10	65	35
C63.04.12	HSK-C 63	12	75	42
C63.04.14	HSK-C 63	14	75	44
C63.04.16	HSK-C 63	16	80	48
C63.04.18	HSK-C 63	18	80	50
C63.04.20	HSK-C 63	20	80	52
C63.04.25	HSK-C 63	25	95	65
C63.04.32	HSK-C 63	32	100	72

Hinweis:

Ab d = 25 mit zwei Spannschrauben

Note:

From d = 25 on two clamping screws

Observation:

A partir de d = 25 avec deux vis de serrage

Lieferumfang:

Mit Spannschraube

Delivery:

With clamping screw

Livraison:

Avec vis de serrage



10.52

**Verwendung:**

Zum Spannen von zylindrischen
Werkzeugschäften mit seitlicher Spann-
fläche nach DIN 1835 Form B (Weldon).

Application:

For mounting straight-shank tools with
lateral flat according to DIN 1835 form B
(Weldon).

Application:

Pour le serrage d'outils avec queue
cylindrique et avec méplat suivant DIN
1835 forme B (Weldon).

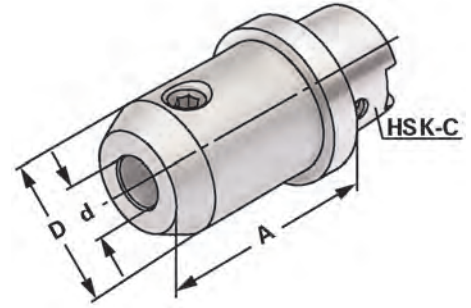
ISO 12164-1
(DIN 69893-1)

HSK - C

 $\nabla \leq 0,003$ G6,3
15.000 min⁻¹

5

Bestell-Nr. Order no. Référence	HSK	d ^{H4}	A	D
C100.04.06	HSK-C 100	6	65	25
C100.04.08	HSK-C 100	8	65	28
C100.04.10	HSK-C 100	10	70	35
C100.04.12	HSK-C 100	12	75	42
C100.04.14	HSK-C 100	14	75	44
C100.04.16	HSK-C 100	16	80	48
C100.04.18	HSK-C 100	18	80	50
C100.04.20	HSK-C 100	20	85	52
C100.04.25	HSK-C 100	25	95	65
C100.04.32	HSK-C 100	32	100	72
C100.04.40	HSK-C 100	40	100	80

Hinweis: Ab d = 25 mit zwei Spannschrauben
Note: From d = 25 on two clamping screws
Observation: A partir de d = 25 avec deux vis de serrage

Lieferumfang: Mit Spannschraube
Delivery: With clamping screw
Livraison: Avec vis de serrage

Gewuchtete Ausführung**Balanced type
Type équilibré**

Bestell-Nr. Order no. Référence	Abmessung Size Dimension
Wuchten auf G 2,5 von vorgewuchteten Kemmler-Werkzeugen Balancing at G 2.5 of pre-balanced Kemmler-tools Équilibrage sur G 2,5 d'outils Kemmler pré-équilibrés	
W25	Ohne Wuchtprotokoll Without balancing report Sans protocole d'équilibrage
W25.2	Mit Wuchtprotokoll With balancing report Avec protocole d'équilibrage
Wuchten von nicht vorgewuchteten Werkzeugen Balancing of unbalanced tools Équilibrage d'outils non-équilibrés	
W25.1	Ohne Wuchtprotokoll Without balancing report Sans protocole d'équilibrage





End mill holders DIN 6359 for end mills DIN 1835-E

DIN 69893 (HSK-C)

Porte-fraises DIN 6359 pour queues cylindriques DIN 1835-E

**Verwendung:**

Zum Spannen von zylindrischen Werkzeugschäften mit geneigter Spannfläche nach DIN 1835 Form E (Whistle Notch).

Application:

For mounting straight-shank tools and inclined flat according to DIN 1835 form E (Whistle Notch).

Application:

Pour le serrage d'outils avec queue cylindrique et avec méplat incliné suivant DIN 1835 forme E (Whistle Notch).

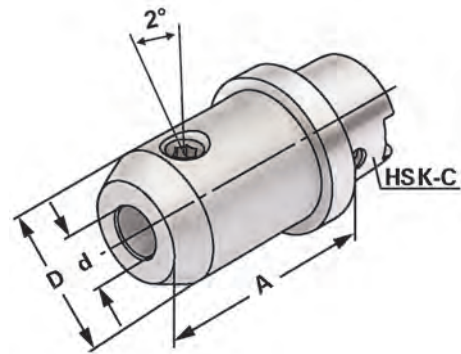
ISO 12164-1
(DIN 69893-1)

HSK - C

 $\nabla \leq 0,003$ G6,3
15.000 min⁻¹

14.04

Bestell-Nr.
Order no.
Référence

HSK

d^{H4}

A

D

C32.05.06	HSK-C 32	6	60	25
C32.05.08	HSK-C 32	8	60	28
C32.05.10	HSK-C 32	10	65	35
C32.05.12	HSK-C 32	12	70	42
C32.05.14	HSK-C 32	14	70	44
C40.05.06	HSK-C 40	6	60	25
C40.05.08	HSK-C 40	8	60	28
C40.05.10	HSK-C 40	10	65	35
C40.05.12	HSK-C 40	12	70	40
C40.05.14	HSK-C 40	14	70	40
C40.05.16	HSK-C 40	16	75	40
C40.05.18	HSK-C 40	18	75	40
C40.05.20	HSK-C 40	20	80	48
C40.05.25	HSK-C 40	25	100	46
C50.05.06	HSK-C 50	6	60	25
C50.05.08	HSK-C 50	8	60	28
C50.05.10	HSK-C 50	10	65	35
C50.05.12	HSK-C 50	12	75	42
C50.05.14	HSK-C 50	14	75	44
C50.05.16	HSK-C 50	16	80	48
C50.05.18	HSK-C 50	18	80	50
C50.05.20	HSK-C 50	20	80	52
C50.05.25	HSK-C 50	25	85	65

Hinweis:

Ab d = 25 mit zwei Spannschrauben

Note:

From d = 25 on two clamping screws

Observation:

A partir de d = 25 avec deux vis de serrage

Lieferumfang:

Mit Spannschraube und axialer Verstellechraube

Delivery:

With clamping screw and axial adjustment bolt

Livraison:

Avec vis de serrage et vis de butée axiale



**Verwendung:**

Zum Spannen von zylindrischen Werkzeugschäften mit geneigter Spannfläche nach DIN 1835 Form E (Whistle Notch).

Application:

For mounting straight-shank tools and inclined flat according to DIN 1835 form E (Whistle Notch).

Application:

Pour le serrage d'outils avec queue cylindrique et avec méplat incliné suivant DIN 1835 forme E (Whistle Notch).

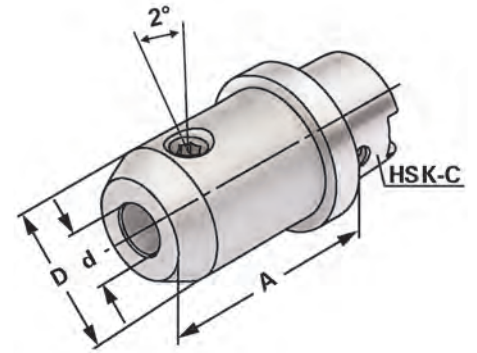
ISO 12164-1
(DIN 69893-1)

HSK - C

 $\nabla \leq 0,003$ G6.3
15.000 min⁻¹

5

Bestell-Nr. Order no. Référence	HSK	d ^{H4}	A	D
C63.05.06	HSK-C 63	6	60	25
C63.05.08	HSK-C 63	8	60	28
C63.05.10	HSK-C 63	10	65	35
C63.05.12	HSK-C 63	12	75	42
C63.05.14	HSK-C 63	14	75	44
C63.05.16	HSK-C 63	16	80	48
C63.05.18	HSK-C 63	18	80	50
C63.05.20	HSK-C 63	20	80	52
C63.05.25	HSK-C 63	25	95	65
C63.05.32	HSK-C 63	32	100	72
C80.05.06	HSK-C 80	6	65	25
C80.05.08	HSK-C 80	8	65	28
C80.05.10	HSK-C 80	10	70	35
C80.05.12	HSK-C 80	12	75	42
C80.05.14	HSK-C 80	14	75	44
C80.05.16	HSK-C 80	16	80	48
C80.05.18	HSK-C 80	18	80	50
C80.05.20	HSK-C 80	20	85	52
C80.05.25	HSK-C 80	25	95	65
C80.05.32	HSK-C 80	32	100	72
C100.05.06	HSK-C 100	6	65	25
C100.05.08	HSK-C 100	8	65	28
C100.05.10	HSK-C 100	10	70	35
C100.05.12	HSK-C 100	12	75	42
C100.05.14	HSK-C 100	14	75	44
C100.05.16	HSK-C 100	16	80	48
C100.05.18	HSK-C 100	18	80	50
C100.05.20	HSK-C 100	20	85	52
C100.05.25	HSK-C 100	25	95	65
C100.05.32	HSK-C 100	32	100	72

Hinweis: Ab d = 25 mit zwei Spannschrauben
Note: From d = 25 on two clamping screws
Observation: A partir de d = 25 avec deux vis de serrage

Lieferumfang: Mit Spannschraube und axialer Verstellechraube
Delivery: With clamping screw and axial adjustment bolt
Livraison: Avec vis de serrage et vis de butée axiale



Shell mill holders DIN 6357 with enlarged contact face
 Porte-fraises à trou lisse DIN 6357 avec face de contact élargie



Verwendung:
 Zur Aufnahme von Messerköpfen und Fräsern mit Quernut.
Application:
 For mounting milling cutters with transversal groove.
Application:
 Pour le serrage de fraises à rainure transversale.

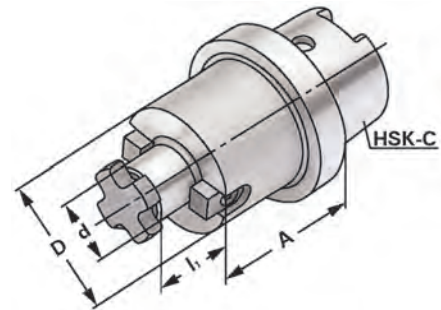

ISO 12164-1 (DIN 69893-1) HSK - C $\lambda \leq 0,005$ G6,3 15.000 min⁻¹

Bestell-Nr. Order no. Référence	HSK	d _{H6}	A	D	l ₁
C40.11.16	HSK-C 40	16	50	40	17
C40.11.22	HSK-C 40	22	60	40	19
C50.11.16	HSK-C 50	16	60	40	17
C50.11.22	HSK-C 50	22	60	50	19
C50.11.27	HSK-C 50	27	60	50	21
C63.11.22	HSK-C 63	22	50	48	19
C63.11.27	HSK-C 63	27	60	60	21
C63.11.32	HSK-C 63	32	60	78	24
C63.11.40	HSK-C 63	40	60	89	27
C80.11.32	HSK-C 80	32	48	78	24
C80.11.40	HSK-C 80	40	60	89	27
C80.11.32.1	HSK-C 80	32	60	78	24
C100.11.22	HSK-C 100	22	50	48	19
C100.11.27	HSK-C 100	27	50	60	21
C100.11.32	HSK-C 100	32	50	78	24
C100.11.40	HSK-C 100	40	60	89	27
C100.11.50	HSK-C 100	50	70	120	30



d = 40/d = 50: Für große Planfräser mit vier zusätzlichen Gewindebohrungen nach DIN 2079.
 For large diameter face mill cutters with four additional threaded holes according to DIN 2079.
 Pour fraises à surfacer à grands diamètres avec quatre trous taraudés additionnels suivant DIN 2079.

Lieferumfang: Mit Mitnehmersteinen und Kreuzschraube.
Delivery: With drivers and cross head retaining screw.
Livraison: Avec tenons et une vis cruciforme.





Verwendung:
Zur Aufnahme von Werkzeugen mit Zylinderschaft.

Application:
For mounting tools with straight shanks.

Application:
Pour le serrage d'outils avec queue cylindrique.

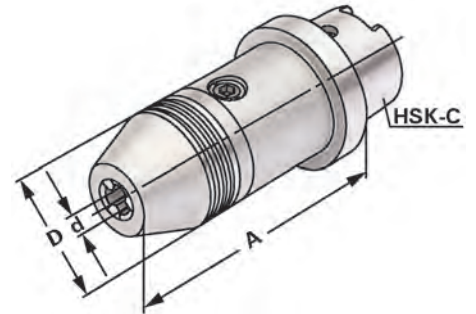

ISO 12164-1
(DIN 69893-1)

HSK - C

$\nabla \leq 0,030$

G6,3
15.000 min⁻¹

14.04

5

Bestell-Nr. Order no. Référence	HSK	Spannbereich Capacity Capacité	A	D
C50.15.13	HSK-C 50	1,0 – 13	110	50
C50.15.16	HSK-C 50	2,5 – 16	115,5	50
C63.15.13	HSK-C 63	1,0 – 13	110	50
C63.15.16	HSK-C 63	2,5 – 16	115,5	50
C100.15.13	HSK-C 100	1,0 – 13	112,5	50
C100.15.16	HSK-C 100	2,5 – 16	118	50

Hinweis: Hohe Präzision und Rundlaufgenauigkeit von $\leq 0,03$ mm. Sichere Spannung des Werkzeuges durch mechanische Spannkraftverstärkung. Kein selbständiges Lösen der Spannung während der Bearbeitung bei Links- oder Rechtslauf, sowie bei Spindelstop. Spannen und Lösen mit Sechskantschlüssel.

Note: *High precision and accurate concentricity of ≤ 0.03 mm. Secure gripping of the tool through mechanical amplification of the clamping force. No automatic slackening of the clamping force while machining with either clockwise or counter clockwise rotation or on spindle stop. Clamping and releasing effected by means of an Allen wrench.*

Observation: Précision élevée et exactitude de circularité de $\leq 0,03$ mm. Serrage sûr de l'outil grâce à l'amplification de la force de serrage. Pas de desserrage intempestif en cours d'usinage lors de la rotation la gauche ou la droite, de même qu'en cas d'arrêt de la broche. Serrage et desserrage en utilisant un clé sur à fourche.

Lieferumfang: Mit Spannschlüssel
Delivery: With wrench
Livraison: Avec clé de serrage



10.23

Boring bar blanks
Barres d'alésage



Verwendung:
Zur Herstellung von Sonderwerkzeugen.
Application:
For the manufacturing of special tools.
Application:
Pour la fabrication d'outils spéciaux.

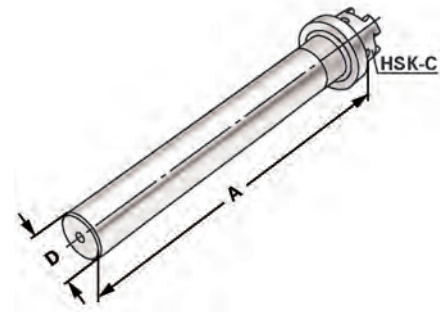

ISO 12164-1
(DIN 69893-1)

HSK - C

Bestell-Nr. Order no. Référence	HSK	A	D
C25.17.32	HSK-C 25	110	32
C32.17.32	HSK-C 32	160	32
C40.17.50	HSK-C 40	160	43
C50.17.50	HSK-C 50	200	50
C63.17.63	HSK-C 63	250	63
C80.17.80	HSK-C 80	250	80
C100.17.93	HSK-C 100	250	93

5

Ausführung: Kegel und Bund gehärtet und geschliffen. Schaft weich zur weiteren Bearbeitung.
Version: Cone and flange hardened and grinded. Soft body for later processing.
Version: Cône et collerette durcis et rectifiés. Corps doux pour un usinage ultérieur.

Gewuchtete Ausführung

Balanced type
Type équilibré



Bestell-Nr. Order no. Référence	Abmessung Size Dimension
---------------------------------------	--------------------------------

**Wuchten auf G 2,5 von vorgewuchteten
Kemmler-Werkzeugen**

Balancing at G 2.5 of pre-balanced Kemmler-tools
Équilibrage sur G 2,5 d'outils Kemmler pré-équilibrés

W25

Ohne Wuchtprotokoll

Without balancing report
Sans protocole d'équilibrage

W25.2

Mit Wuchtprotokoll

With balancing report
Avec protocole d'équilibrage

Wuchten von nicht vorgewuchteten Werkzeugen
Balancing of unbalanced tools
Équilibrage d'outils non-équilibrés

W25.1

Ohne Wuchtprotokoll

Without balancing report
Sans protocole d'équilibrage



Verwendung:
Zur Abnahme von Werkzeugmaschinen gemäß ISO-Empfehlung R230 oder zur Überprüfung der Werkzeugspindel.

Application:
For the inspection of machine tools according to ISO recommendation R230 or for testing the tool spindle.

Application:
Pour l'inspection de machine-outils suite à la recommandation ISO R230 ou pour la vérification de la broche.

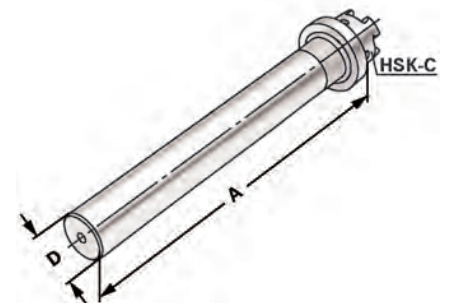

ISO 12164-1
(DIN 69893-1)

HSK - C

$\lambda \leq 0,003$

5

Bestell-Nr. Order no. Référence	HSK	D	A	Toleranz Tolerance Tolérance	max. Rundlaufabweichung max. concentricity deviation Faux-rond max.
C32.18.25	HSK-C 32	25	160	0,003	0,003
C40.18.25	HSK-C 40	25	160	0,003	0,003
C50.18.32	HSK-C 50	32	300	0,003	0,003
C63.18.40	HSK-C 63	40	300	0,003	0,003
C80.18.40	HSK-C 80	40	300	0,003	0,003
C100.18.50	HSK-C 100	50	300	0,003	0,003

Lieferumfang: Auslieferung mit Prüfprotokoll
Delivery: Delivery with test certificate
Livraison: Livraison avec rapport d'essais

Holzkasten für Kontrolldorne

Wooden box for test arbors
Coffret en bois pour mandrins de contrôle



Verwendung:
Zur Aufbewahrung von Kontrolldornen.

Application:
For the storage of test arbors.

Application:
Pour la conservation de mandrins de contrôle.



Bestell-Nr.
Order no.
Référence

Abmessung
Size
Dimension

für Kegelgrößen
for cones
pour cônes

701.18

460 × 130 × 115

HSK 32 / 40 / 50 / 63 / 80 / 100



Technische Datenblätter, STEP/STL Modelle für die Simulation der NC-Programme und DXF-Zeichnungen zur Erstellung des Einrichteblattes stehen Online zur Verfügung.

Technical data sheets, STEP/STL models for the simulation of NC programs and DXF drawings to create the tooling sheet are online available.

Fiches techniques, STEP/STL modèles techniques pour la simulation de programmes CN et dessins DXF pour créer la feuille d'installation sont disponible online.

Sie können unsere Kataloge entweder direkt im Browser betrachten oder sie auf Ihren PC, Smartphone oder Tablet herunterladen (PDF-Reader notwendig).

You can view our catalogues either directly in the browser or download to your PC, smartphone or tablet (PDF reader required).

Vous pouvez consulter nos catalogues directement dans le navigateur ou télécharger sur votre PC, smartphone ou tablet (lecteur PDF requis).



Auf unserer Internetseite können Sie die Lagerverfügbarkeit prüfen - auch auf Mobilgeräten.

On our website you can check the stock availability - also on mobile devices.

Vous pouvez également vérifier la disponibilité de nos produits sur le site Internet - ainsi que sur vos appareils

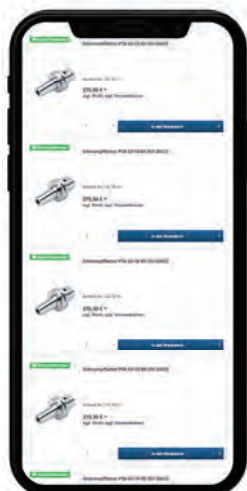



Verwendung:
Zur Aufnahme von Werkzeugen mit Zylinderschaft nach DIN 1835 Form A+B+E und DIN 6535 Form HA+HB+HE

Application:
For mounting straight-shank tools acc. DIN 1835 form A+B+E and DIN 6535 form HA+HB+HE.

Application:
Pour le serrage d'outils avec queue cylindrique suivant DIN 1835 forme A+B+E et DIN 6535 forme HA+HB+HE.

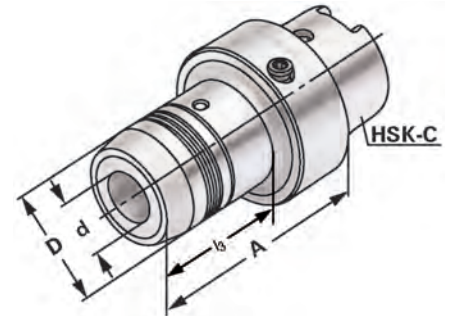

ISO 12164-1
(DIN 69893-1)

HSK - C

$\nabla \leq 0,003$

G6,3
15.000 min⁻¹

14.04

5

Bestell-Nr. Order no. Référence	HSK	d	A	D	l ₁	l ₂	l ₃
C25.H06	HSK-C 25	6	60	26	37	10	38
C25.H08	HSK-C 25	8	60	28	37	10	38
C25.H10	HSK-C 25	10	65	30	42	10	38
C32.H06	HSK-C 32	6	60	26	37	10	35
C32.H08	HSK-C 32	8	60	28	37	10	36
C32.H10	HSK-C 32	10	65	30	42	10	52
C32.H12	HSK-C 32	12	70	32	47	10	-
C32.H14	HSK-C 32	14	75	34	47	10	65
C32.H08.1	HSK-C 32	8	67	26	37	10	42
C32.H10.1	HSK-C 32	10	72,5	30	42	10	48,5
C32.H12.1	HSK-C 32	12	76	32	47	10	-
C40.H06	HSK-C 40	6	60	26	37	10	35
C40.H08	HSK-C 40	8	60	28	37	10	36
C40.H10	HSK-C 40	10	65	30	42	10	38
C40.H12	HSK-C 40	12	70	32	47	10	47
C40.H14	HSK-C 40	14	80	34	47	10	49
C40.H16	HSK-C 40	16	80	38	52	10	49
C40.H18	HSK-C 40	18	80	40	52	10	49
C40.H20	HSK-C 40	20	80	40	52	10	49
C50.H06	HSK-C 50	6	60	26	37	10	33
C50.H08	HSK-C 50	8	60	28	37	10	33
C50.H10	HSK-C 50	10	65	30	42	10	39
C50.H12	HSK-C 50	12	75	32	47	10	44
C50.H14	HSK-C 50	14	75	34	47	10	46
C50.H16	HSK-C 50	16	80	38	52	10	51
C50.H18	HSK-C 50	18	80	40	52	10	52
C50.H20	HSK-C 50	20	80	42	52	10	58

Lieferumfang: Mit Spannschlüssel
Delivery: With wrench
Livraison: Avec clé de serrage

l₁ = max. Einstecktiefe
l₁ = max. clamping depth
l₁ = max. profondeur d'insertion

l₂ = max. Verstellweg
l₂ = max. length adjustment range
l₂ = max. course de réglage



Verwendung:
Zur Aufnahme von Werkzeugen mit Zylinderschaft nach DIN 1835 Form A+B+E und DIN 6535 Form HA+HB+HE

Application:
For mounting straight-shank tools acc. DIN 1835 form A+B+E and DIN 6535 form HA+HB+HE.

Application:
Pour le serrage d'outils avec queue cylindrique suivant DIN 1835 forme A+B+E et DIN 6535 forme HA+HB+HE.

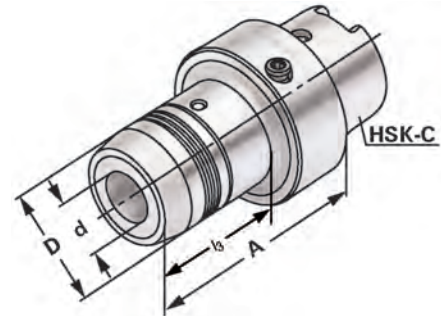

ISO 12164-1 (DIN 69893-1) HSK - C $\lambda \leq 0,003$ G6,3 15.000 min⁻¹ ⓘ 14.04

Bestell-Nr. Order no. Référence	HSK	d	A	D	l ₁	l ₂	l ₃
C63.H06	HSK-C 63	6	60	26	37	10	29
C63.H08	HSK-C 63	8	60	28	37	10	29
C63.H10	HSK-C 63	10	65	30	42	10	35
C63.H12	HSK-C 63	12	75	32	47	10	40
C63.H14	HSK-C 63	14	75	34	47	10	42
C63.H16	HSK-C 63	16	80	38	52	10	47
C63.H18	HSK-C 63	18	80	40	52	10	48
C63.H20	HSK-C 63	20	80	42	52	10	54
C63.H25	HSK-C 63	25	95	50	58	10	51
C63.H32	HSK-C 63	32	100	60	62	10	59



Lieferumfang: Mit Spannschlüssel
Delivery: With wrench
Livraison: Avec clé de serrage

l₁ = max. Einstecktiefe l₂ = max. Verstellweg
l₁ = max. clamping depth l₂ = max. length adjustment range
l₁ = max. profondeur d'insertion l₂ = max. course de réglage

Gewuchtete Ausführung



Balanced type
Type équilibré

Bestell-Nr. Order no. Référence	Abmessung Size Dimension
---------------------------------------	--------------------------------

- Wuchten auf G 2,5 von vorgewuchteten Kemmler-Werkzeugen**
Balancing at G 2.5 of pre-balanced Kemmler-tools
Équilibrage sur G 2,5 d'outils Kemmler pré-équilibrés
- W25 **Ohne Wuchtprotokoll**
Without balancing report
Sans protocole d'équilibrage
- W25.2 **Mit Wuchtprotokoll**
With balancing report
Avec protocole d'équilibrage
- Wuchten von nicht vorgewuchteten Werkzeugen**
Balancing of unbalanced tools
Équilibrage d'outils non-équilibrés
- W25.1 **Ohne Wuchtprotokoll**
Without balancing report
Sans protocole d'équilibrage





Shrink chucks 4,5° for mounting of solid carbide and HSS-tool shanks

Mandrins de frettage 4,5° pour le serrage de queues d'outils carbures de type HM et HSS

**Verwendung:**

Zur Aufnahme von Werkzeugen mit Zylinderschaft.

Application:

For mounting straight-shank tools.

Application:

Pour le serrage d'outils avec queue cylindrique.

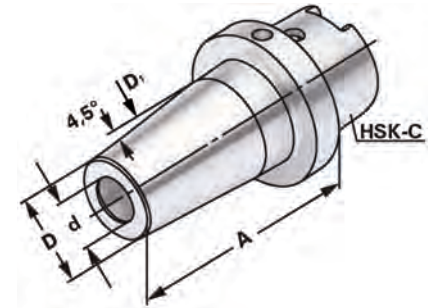
ISO 12164-1
(DIN 69893-1)

HSK - C

 $\nabla \leq 0,003$ G2.5
25.000 min⁻¹

5

Bestell-Nr. Order no. Référence	HSK	d	A	D	D ₁	l ₁	l ₂
C32.70.06	HSK-C 32	6	65	21	27	36	10
C32.70.08	HSK-C 32	8	65	21	27	36	10
C32.70.10	HSK-C 32	10	65	24	32	42	10
C32.70.12	HSK-C 32	12	75	24	32	47	10
C32.70.14	HSK-C 32	14	80	27	34	47	10
C32.70.16	HSK-C 32	16	80	27	34	50	10
C32.70.06.1	HSK-C 32	6	75	21	27	36	10
C32.70.08.1	HSK-C 32	8	75	21	27	36	10
C32.70.10.1	HSK-C 32	10	80	24	32	42	10
C40.70.03	HSK-C 40	3	70	11	15	10	-
C40.70.04	HSK-C 40	4	70	14	22	20	5
C40.70.05	HSK-C 40	5	70	16	22	20	5
C40.70.06	HSK-C 40	6	70	21	27	36	10
C40.70.08	HSK-C 40	8	70	21	27	36	10
C40.70.10	HSK-C 40	10	70	24	32	42	10
C40.70.12	HSK-C 40	12	80	24	32	47	10
C40.70.14	HSK-C 40	14	80	27	34	47	10
C40.70.16	HSK-C 40	16	80	27	34	50	10
C40.70.18	HSK-C 40	18	80	33	42	50	10
C40.70.20	HSK-C 40	20	80	33	42	52	10
C50.70.06	HSK-C 50	6	70	21	27	36	10
C50.70.08	HSK-C 50	8	70	21	27	36	10
C50.70.10	HSK-C 50	10	75	24	32	42	10
C50.70.12	HSK-C 50	12	75	24	32	47	10
C50.70.14	HSK-C 50	14	80	27	34	47	10
C50.70.16	HSK-C 50	16	85	27	34	50	10
C50.70.18	HSK-C 50	18	85	33	42	50	10
C50.70.20	HSK-C 50	20	90	33	42	52	10

Hinweis: Aufnahme für Induktiv-, Kontakt- und Heißluftschumpfergeräte geeignet.
Schafttoleranz bei Ø 3, 4 und 5 mm = h₄, bei Ø 6 - Ø 32 mm = h₆

Note: Toolholders suitable for induction-, contact- and hot air shrink units.
Ø 3, 4, 5 with h₄-tolerance and Ø 6 - Ø 32 with h₆-tolerance

Observation: Porte-outils convenables pour machines à fretter par induction, par contact, ou par air chaud.
Ø 3, 4, 5 avec h₄-tolerance et Ø 6 - Ø 32 avec h₆-tolerance

l₁ = max. Einstecktiefe
l₁ = max. clamping depth
l₁ = max. profondeur d'insertion
l₂ = max. Verstellweg
l₂ = max. length adjustment range
l₂ = max. course de réglage

Schrumpffutter 4,5° mit Kühlkanälen

zum Spannen von HM und HSS Werkzeugschäften

ISO 12164 (HSK-C)

DIN 69893 (HSK-C)



Shrink chucks 4,5° for mounting of solid carbide and HSS-tool shanks

Mandrins de frettage 4,5° pour le serrage de queues d'outils carbures de type HM et HSS



Verwendung:
Zur Aufnahme von Werkzeugen mit Zylinderschaft.

Application:
For mounting straight-shank tools.

Application:
Pour le serrage d'outils avec queue cylindrique.

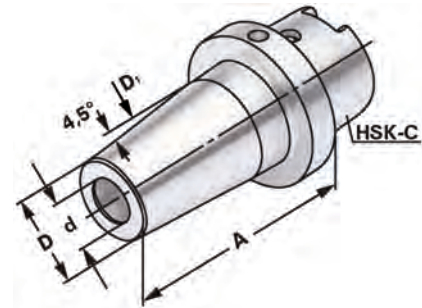

ISO 12164-1
(DIN 69893-1)

HSK - C

$\nabla \leq 0,003$

G2,5
25.000 min⁻¹

Bestell-Nr. Order no. Référence	HSK	d	A	D	D ₁	l ₁	l ₂
C63.70.06	HSK-C 63	6	70	21	27	36	10
C63.70.08	HSK-C 63	8	70	21	27	36	10
C63.70.10	HSK-C 63	10	75	24	32	42	10
C63.70.12	HSK-C 63	12	80	24	32	47	10
C63.70.14	HSK-C 63	14	80	27	34	47	10
C63.70.16	HSK-C 63	16	85	27	34	50	10
C63.70.18	HSK-C 63	18	85	33	42	50	10
C63.70.20	HSK-C 63	20	90	33	42	52	10
C63.70.25	HSK-C 63	25	100	44	53	58	10
C63.70.32	HSK-C 63	32	110	44	53	61	10

5

Hinweis: Aufnahme für Induktiv-, Kontakt- und Heißluftschumpfgeräte geeignet.
Schafttoleranz bei $\varnothing 6 - \varnothing 32 \text{ mm} = h_6$

Note: *Toolholders suitable for induction-, contact- and hot air shrink units.
 $\varnothing 6 - \varnothing 32$ with h_6 -tolerance*

Observation: Porte-outils convenables pour machines à fretter par induction,
par contact, ou par air chaud.
 $\varnothing 6 - \varnothing 32$ avec h_6 -tolerance

l₁ = max. Einstecktiefe l₂ = max. Verstellweg
l₁ = max. clamping depth l₂ = max. length adjustment range
l₁ = max. profondeur d'insertion l₂ = max. course de réglage

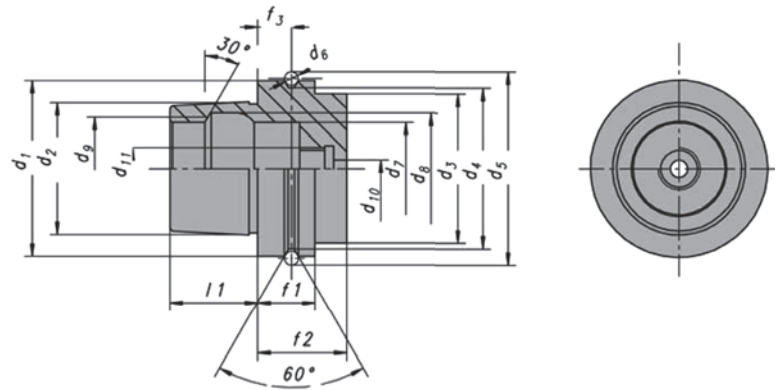

Toolholders DIN 69893-5 form E
Porte-outils DIN 69893-5 forme E
Vorgewuchtet
Pre-balanced
Pré-équilibré
G 6,3 15.000 min⁻¹
G 2,5 Feinwuchten gegen Aufpreis
G 2.5 Fine balancing at extra charge
G 2,5 Equilibrage fin contre un supplément

d ₁	d ₂	d ₃	d ₄	d ₅ _{-0,1}	d ₆ _{-0,1}	d ₈ ^{H10}	d ₉ ^{H11}	d ₁₀	d ₁₁	f ₁ _{-0,1}	f ₂ min.	f ₃ ^{±0,1}	l ₁ _{-0,2}	l ₂ js10	l ₃
25	19 ^{+0,006} _{+0,004}	18,15	20	22	28,5	14	16,4	15	M8x1	10	20	4,5	13	7,21	8,5
32	24 ^{+0,007} _{+0,005}	23,27	26	26,5	37	17	21	19	M10x1	20	35	16	16	8,92	7,3
40	30 ^{+0,007} _{+0,005}	29,05	34	34,8	45	21	25,5	23	M12x1	20	35	16	20	11,42	9,5
50	38 ^{+0,009} _{+0,006}	36,90	42	43	59,3	26	32	29	M16x1	26	42	18	25	14,13	11,0
63	48 ^{+0,011} _{+0,007}	46,53	53	55	72,3	34	40	37	M18x1	26	42	18	32	18,13	14,7

5
Werkstoff: Legierter Einsatzstahl mit einer Zugfestigkeit im Kern von min. 1200 N / mm². Einsatzgehärtet HRC 60 ± 2 (HV 700 ± 50), Härtetiefe 0,8 mm ± 0,2 mm, brüniert und präzisionsgeschliffen.

Genauigkeit: Kegelwinkel – Toleranzqualität < AT 3 nach DIN 7187.

Material: *Alloyed case-hardened steel, tensile core strength of min. 1200 N / mm². Case hardened HRC 60 ± 2 (HV 700 ± 50), hardening depth 0.8 mm ± 0.2 mm, black-finished and precisely grinded.*
Accuracy: *Quality of taper < AT 3 according to DIN 7187.*
Matière: Acier de cémentation allié. Résistance à la traction dans le noyau de min 1200 N / mm². Cémentation à HRC 60 ± 2 (HV 700 ± 50), profondeur de cémentation 0,8 mm ± 0,2 mm, bruni et rectifié précisément.

Précision: Qualité du cône < AT 3 suivant DIN 7187.



Index
Sommaire





DIN 6499 (ISO 15488) System ER

Collet chucks for collets DIN 6499 (ISO 15488) ER-system

Mandrins à pinces pour pinces DIN 6499 (ISO 15488) système ER

**Verwendung:**

Zur Aufnahme von Werkzeugen mit Zylinderschaft in Spannzangen.

Application:

For mounting straight-shank tools in collets.

Application:

Pour le serrage d'outils avec queue cylindrique dans des pinces de serrage.

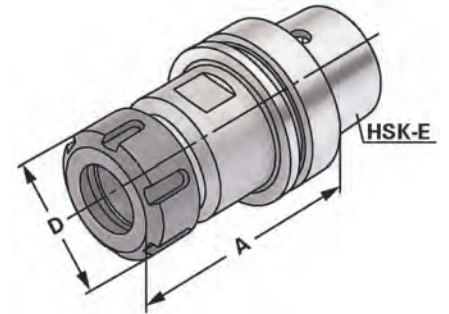
ISO 12164-1
(DIN 69893-1)

HSK - E

 $\nabla \leq 0,003$ G6,3
15.000 min⁻¹

5

Bestell-Nr. Order no. Référence	HSK	Spannbereich Capacity Capacité	A	D
E25.02.10.M	HSK-E 25	1 – 10 (ER 16) Mini	52	22
E25.02.10	HSK-E 25	1 – 10 (ER 16)	65	28
E25.02.16.M	HSK-E 25	1 – 16 (ER 25) Mini	70	35
E32.02.07.M	HSK-E 32	1 – 7 (ER 11) Mini	60	16
E32.02.10.M	HSK-E 32	1 – 10 (ER 16) Mini	65	22
E32.02.13.M	HSK-E 32	1 – 13 (ER 20) Mini	75	28
E32.02.16.M	HSK-E 32	1 – 16 (ER 25) Mini	85	35
E32.02.20	HSK-E 32	2 – 20 (ER 32)	95	50
E40.02.10.M	HSK-E 40	1 – 10 (ER 16) Mini	100	22
E40.02.10	HSK-E 40	1 – 10 (ER 16)	65	28
E40.02.16	HSK-E 40	1 – 16 (ER 25)	75	42
E40.02.20	HSK-E 40	2 – 20 (ER 32)	100	50
E50.02.10	HSK-E 50	1 – 10 (ER 16)	80	28
E50.02.16	HSK-E 50	1 – 16 (ER 25)	80	42
E50.02.20	HSK-E 50	2 – 20 (ER 32)	85	50
E50.02.26	HSK-E 50	3 – 26 (ER 40)	100	63
E63.02.10.1	HSK-E 63	1 – 10 (ER 16)	75	28
E63.02.16	HSK-E 63	1 – 16 (ER 25)	80	42
E63.02.20	HSK-E 63	2 – 20 (ER 32)	90	50
E63.02.26	HSK-E 63	3 – 26 (ER 40)	120	63

Lieferumfang: Mit gewuchteter Spannmutter
Delivery: With balanced clamping nut
Livraison: Avec écrou de serrage équilibré



End mill holders DIN 6359 for end mills DIN 1835-B
Porte-fraises DIN 6359 pour queues cylindriques DIN 1835-B



Verwendung:
Zum Spannen von zylindrischen Werkzeugschäften mit seitlicher Spannfläche nach DIN 1835 Form B (Weldon).

Application:
For mounting straight-shank tools with lateral flat according to DIN 1835 form B (Weldon).

Application:
Pour le serrage d'outils avec queue cylindrique et avec méplat suivant DIN 1835 forme B (Weldon).

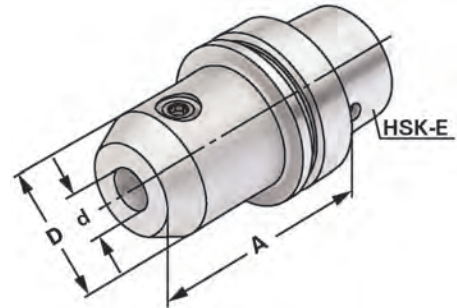

ISO 12164-1
(DIN 69893-1)

HSK - E

$\nabla \leq 0,003$

G6,3
15.000 min⁻¹

14.04

Bestell-Nr. Order no. Référence	HSK	d ^{H4}	A	D
E32.04.06	HSK-E 32	6	60	25
E32.04.08	HSK-E 32	8	60	28
E32.04.10	HSK-E 32	10	65	35
E40.04.06	HSK-E 40	6	60	25
E40.04.08	HSK-E 40	8	60	28
E40.04.10	HSK-E 40	10	60	35
E40.04.12	HSK-E 40	12	70	42
E40.04.14	HSK-E 40	14	75	44
E40.04.16	HSK-E 40	16	75	48
E40.04.20	HSK-E 40	20	75	52
E50.04.06	HSK-E 50	6	65	25
E50.04.08	HSK-E 50	8	65	28
E50.04.10	HSK-E 50	10	65	35
E50.04.12	HSK-E 50	12	80	42
E50.04.14	HSK-E 50	14	80	44
E50.04.16	HSK-E 50	16	80	48
E50.04.18	HSK-E 50	18	80	50
E50.04.20	HSK-E 50	20	80	52
E50.04.25	HSK-E 50	25	102	65
E63.04.06	HSK-E 63	6	65	25
E63.04.08	HSK-E 63	8	65	28
E63.04.10	HSK-E 63	10	65	35
E63.04.12	HSK-E 63	12	80	42
E63.04.14	HSK-E 63	14	80	44
E63.04.16	HSK-E 63	16	80	48
E63.04.18	HSK-E 63	18	80	50
E63.04.20	HSK-E 63	20	80	52
E63.04.25	HSK-E 63	25	110	65
E63.04.32	HSK-E 63	32	110	72
E63.04.40	HSK-E 63	40	120	63

Hinweis: Ab d = 25 mit zwei Spannschrauben
Note: From d = 25 on two clamping screws
Observation: A partir de d = 25 avec deux vis de serrage

Lieferumfang: Mit Spannschraube
Delivery: With clamping screw
Livraison: Avec vis de serrage



End mill holders DIN 6359 for end mills DIN 1835-E

Porte-fraises DIN 6359 pour queues cylindriques DIN 1835-E

**Verwendung:**

Zum Spannen von zylindrischen Werkzeugschäften mit geneigter Spannfläche nach DIN 1835 Form E (Whistle Notch).

Application:

For mounting straight-shank tools and inclined flat according to DIN 1835 form E (Whistle Notch).

Application:

Pour le serrage d'outils avec queue cylindrique et avec méplat incliné suivant DIN 1835 forme E (Whistle Notch).

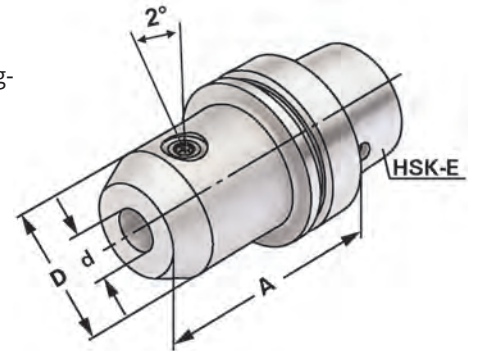
ISO 12164-1
(DIN 69893-1)

HSK - E

 $\nabla \leq 0,003$ G6,3
15.000 min⁻¹

5

Bestell-Nr. Order no. Référence	HSK	d ^{H4}	A	D
E32.05.06	HSK-E 32	6	60	25
E32.05.08	HSK-E 32	8	80	28
E32.05.10	HSK-E 32	10	80	35
E40.05.06	HSK-E 40	6	60	25
E40.05.08	HSK-E 40	8	80	28
E40.05.10	HSK-E 40	10	80	35
E40.05.12	HSK-E 40	12	90	42
E40.05.14	HSK-E 40	14	90	44
E40.05.16	HSK-E 40	16	90	48
E50.05.06	HSK-E 50	6	80	25
E50.05.08	HSK-E 50	8	80	28
E50.05.10	HSK-E 50	10	80	35
E50.05.12	HSK-E 50	12	90	42
E50.05.14	HSK-E 50	14	90	44
E50.05.16	HSK-E 50	16	90	48
E50.05.18	HSK-E 50	18	90	50
E50.05.20	HSK-E 50	20	100	52
E63.05.06	HSK-E 63	6	80	25
E63.05.08	HSK-E 63	8	80	28
E63.05.10	HSK-E 63	10	80	35
E63.05.12	HSK-E 63	12	90	42
E63.05.14	HSK-E 63	14	90	44
E63.05.16	HSK-E 63	16	100	48
E63.05.18	HSK-E 63	18	100	50
E63.05.20	HSK-E 63	20	100	52
E63.05.25	HSK-E 63	25	110	65
E63.05.32	HSK-E 63	32	110	72

Hinweis: Ab d = 25 mit zwei Spannschrauben
Note: From d = 25 on two clamping screws
Observation: A partir de d = 25 avec deux vis de serrage

Lieferumfang: Mit Spannschraube und axialer Verstellechraube
Delivery: With clamping screw and axial adjustment bolt
Livraison: Avec vis de serrage et vis de butée axiale





mit vergrößerter Anlagefläche

Shell mill holders DIN 6357 with enlarged contact face
 Porte-fraises à trou lisse DIN 6357 avec face de contact élargie



Verwendung:
 Zur Aufnahme von Messerköpfen und Fräsern mit Quernut.
Application:
 For mounting milling cutters with transversal groove.
Application:
 Pour le serrage de fraises à rainure transversale.

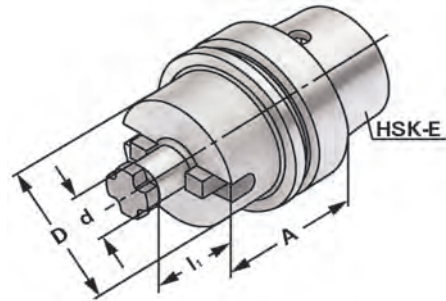

ISO 12164-1 (DIN 69893-1) HSK - E $\lambda \leq 0,005$ G6,3 15.000 min⁻¹

Bestell-Nr. Order no. Référence	HSK	d _{h6}	A	l ₁	D
E32.11.16	HSK-E 32	16	50	17	34
E40.11.16	HSK-E 40	16	50	17	34
E40.11.22	HSK-E 40	22	50	19	48
E40.11.27	HSK-E 40	27	55	21	60
E50.11.16	HSK-E 50	16	50	17	38
E50.11.22	HSK-E 50	22	60	19	48
E50.11.27	HSK-E 50	27	60	21	58
E50.11.32	HSK-E 50	32	60	24	65
E63.11.16	HSK-E 63	16	50	17	38
E63.11.22	HSK-E 63	22	60	19	48
E63.11.27	HSK-E 63	27	60	21	58
E63.11.32	HSK-E 63	32	60	24	65
E63.11.40	HSK-E 63	40	60	27	89



Lieferumfang: Mit Mitnehmersteinen und Kreuzschraube.
Delivery: With drivers and cross head retaining screw.
Livraison: Avec tenons and une vis cruciforme.

Gewuchtete Ausführung



Balanced type
Type équilibré

Bestell-Nr. Order no. Référence	Abmessung Size Dimension
---------------------------------------	--------------------------------

- Wuchten auf G 2,5 von vorgewuchteten Kemmler-Werkzeugen**
Balancing at G 2.5 of pre-balanced Kemmler-tools
 Equilibrage sur G 2,5 d'outils Kemmler pré-équilibrés
- W25 **Ohne Wuchtprotokoll**
Without balancing report
Sans protocole d'équilibrage
 - W25.2 **Mit Wuchtprotokoll**
With balancing report
Avec protocole d'équilibrage
- Wuchten von nicht vorgewuchteten Werkzeugen**
Balancing of unbalanced tools
 Equilibrage d'outils non-équilibrés
- W25.1 **Ohne Wuchtprotokoll**
Without balancing report
Sans protocole d'équilibrage



CNC-Drill chucks for clockwise and counter clockwise rotation
Mandrins de perçage CNC pour rotation gauche-droite



Verwendung:
Zur Aufnahme von Werkzeugen mit Zylinderschaft.
Application:
For mounting tools with straight shanks.
Application:
Pour le serrage d'outils avec queue cylindrique.

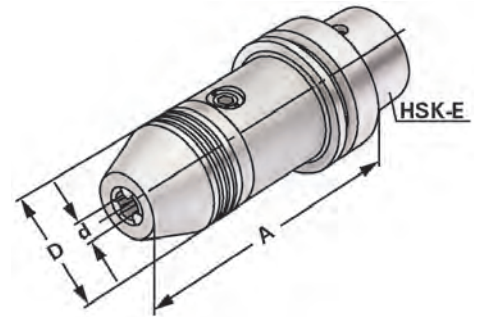

ISO 12164-1
(DIN 69893-1)

HSK - E

$\nabla \leq 0,030$

G6,3
15.000 min⁻¹



5

Bestell-Nr. Order no. Référence	HSK	Spannbereich Capacity Capacité	A	D
E25.15.08	HSK-E 25	0 – 8	70,0	36
E32.15.08	HSK-E 32	0 – 8	75,0	36
E40.15.08	HSK-E 40	0 – 8	80,0	36
E40.15.13	HSK-E 40	1,0 – 13	119,0	50
E40.15.16	HSK-E 40	2,5 – 16	124,5	50
E50.15.08	HSK-E 50	0 – 8	80	36
E50.15.13	HSK-E 50	1,0 – 13	121,0	50
E50.15.16	HSK-E 50	2,5 – 16	126,5	50
E63.15.13	HSK-E 63	1,0 – 13	123,5	50
E63.15.16	HSK-E 63	2,5 – 16	129,0	50

Hinweis: Hohe Präzision und Rundlaufgenauigkeit von $\leq 0,03$ mm. Sichere Spannung des Werkzeuges durch mechanische Spannkraftverstärkung. Kein selbständiges Lösen der Spannung während der Bearbeitung bei Links- oder Rechtslauf, sowie bei Spindelstop. Spannen und Lösen mit Sechskantschlüssel.

Note: High precision and accurate concentricity of ≤ 0.03 mm. Secure gripping of the tool through mechanical amplification of the clamping force. No automatic slacking of the clamping force while machining with either clockwise or counter clockwise rotation or on spindle stop. Clamping and releasing effected by means of an Allen wrench.

Observation: Précision élevée et exactitude de circularité de $\leq 0,03$ mm. Serrage sûr de l'outil grâce à l'amplification de la force de serrage. Pas de desserrage intempestif en cours d'usinage lors de la rotation la gauche ou la droite, de même qu'en cas d'arrêt de la broche. Serrage et desserrage en utilisant un clé sur à fourche.

Lieferumfang: Mit Spannschlüssel
Delivery: With wrench
Livraison: Avec clé de serrage



10.23

Boring bar blanks
Barres d'alésage



Verwendung:
Zur Herstellung von Sonderwerkzeugen.
Application:
For the manufacturing of special tools.
Application:
Pour la fabrication d'outils spéciaux.

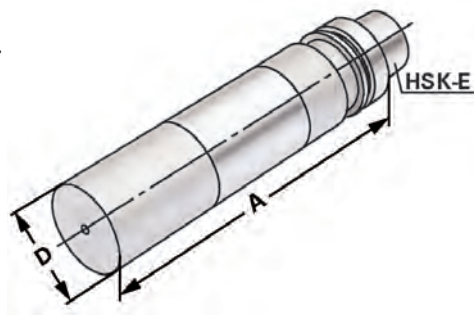

ISO 12164-1
(DIN 69893-1)

HSK - E

Bestell-Nr. Order no. Référence	HSK	A	D
E25.17.30	HSK-E 25	40	30,0
E32.17.32	HSK-E 32	100	32,5
E40.17.40	HSK-E 40	125	40,5
E50.17.50	HSK-E 50	125	50,5
E63.17.63	HSK-E 63	250	63,5

5

Ausführung: Kegel und Bund gehärtet und geschliffen. Schaft weich zur weiteren Bearbeitung.
Version: *Cone and flange hardened and grinded. Soft body for later processing.*
Version: Cône et collerette durcis et rectifiés. Corps doux pour un usinage ultérieur.



Hydraulic expansion chucks
Mandrins expansibles hydrauliques



Verwendung:
Zur Aufnahme von Werkzeugen mit Zylinderschaft nach DIN 1835 Form A+B+E und DIN 6535 Form HA+HB+HE (größer Ø 20 mm nur mit Reduzierung).

Application:
For mounting straight-shank tools acc. DIN 1835 form A+B+E and DIN 6535 form HA+HB+HE (larger than dia. 20 mm only with reduction sleeve).

Application:
Pour le serrage d'outils avec queue cylindrique suivant DIN 1835 forme A+B+E et DIN 6535 forme HA+HB+HE.

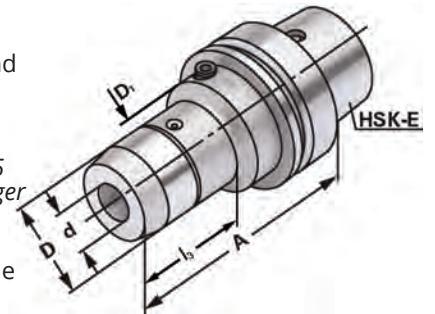

ISO 12164-1
(DIN 69893-1)

HSK - E

$\nabla \leq 0,003$

G6,3
15.000 min⁻¹

14.04

5

Bestell-Nr. Order no. Référence	HSK	d	A	D	D ₁	l ₁	l ₂	l ₃
E25.H06	HSK-E 25	6	70	26	20	37	10	38
E25.H08	HSK-E 25	8	80	28	20	37	10	-
E25.H10	HSK-E 25	10	85	30	20	42	10	-
E25.H12	HSK-E 25	12	90	32	20	47	10	-
E32.H06	HSK-E 32	6	80	26	26	37	10	60
E32.H08	HSK-E 32	8	80	28	26	37	10	-
E32.H10	HSK-E 32	10	85	30	26	42	10	-
E32.H12	HSK-E 32	12	90	32	26	47	10	-
E40.H06	HSK-E 40	6	80	26	34	37	10	35
E40.H08	HSK-E 40	8	80	28	34	37	10	36
E40.H10	HSK-E 40	10	85	30	34	42	10	41
E40.H12	HSK-E 40	12	90	32	34	47	10	47
E40.H14	HSK-E 40	14	90	34	34	47	10	70
E40.H16	HSK-E 40	16	100	38	34	52	10	-
E40.H20	HSK-E 40	20	100	42	34	52	10	-
E50.H06	HSK-E 50	6	80	26	42	37	10	54
E50.H08	HSK-E 50	8	80	28	42	37	10	54
E50.H10	HSK-E 50	10	85	30	42	42	10	59
E50.H12	HSK-E 50	12	90	32	42	47	10	64
E50.H14	HSK-E 50	14	90	34	42	47	10	64
E50.H16	HSK-E 50	16	95	38	42	52	10	69
E50.H18	HSK-E 50	18	95	40	42	52	10	69
E50.H20	HSK-E 50	20	100	42	42	52	10	74

Lieferumfang: Mit Spannschlüssel
Delivery: With wrench
Livraison: Avec clé de serrage

l₁ = max. Einstecktiefe l₂ = max. Verstellweg
l₁ = max. clamping depth l₂ = max. length adjustment range
l₁ = max. profondeur d'insertion l₂ = max. course de réglage





Hydraulic expansion chucks Mandrins expansibles hydrauliques



Verwendung:
Zur Aufnahme von Werkzeugen mit Zylinderschaft nach DIN 1835 Form A+B+E und DIN 6535 Form HA+HB+HE (größer Ø 20 mm nur mit Reduzierung).

Application:
For mounting straight-shank tools acc. DIN 1835 form A+B+E and DIN 6535 form HA+HB+HE (larger than dia. 20 mm only with reduction sleeve).

Application:
Pour le serrage d'outils avec queue cylindrique suivant DIN 1835 forme A+B+E et DIN 6535 forme HA+HB+HE.

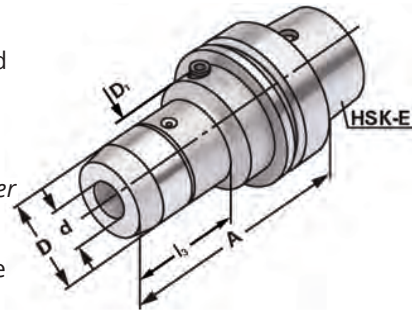

ISO 12164-1 (DIN 69893-1) HSK - E $\nabla \leq 0,003$ G6,3 15.000 min⁻¹



Bestell-Nr. Order no. Référence	HSK	d	A	D	D ₁	l ₁	l ₂	l ₃
E63.H06	HSK-E 63	6	80	26	50	37	10	33
E63.H08	HSK-E 63	8	80	28	50	37	10	33,5
E63.H10	HSK-E 63	10	85	30	50	42	10	39
E63.H12	HSK-E 63	12	90	32	50	47	10	44,5
E63.H14	HSK-E 63	14	90	34	50	47	10	46
E63.H16	HSK-E 63	16	95	38	50	52	10	51,5
E63.H18	HSK-E 63	18	95	40	50	52	10	52
E63.H20	HSK-E 63	20	100	42	50	52	10	58
E63.H25	HSK-E 63	25	120	50	50	58	10	59
E63.H32	HSK-E 63	32	125	60	60	62	10	59

Lieferumfang: Mit Spannschlüssel
Delivery: With wrench
Livraison: Avec clé de serrage

l₁ = max. Einstecktiefe l₂ = max. Verstellweg
l₁ = max. clamping depth l₂ = max. length adjustment range
l₁ = max. profondeur d'insertion l₂ = max. course de réglage





zum Spannen von HM und HSS Werkzeugschäften

Shrink chucks 4,5° for mounting of solid carbide and HSS-tool shanks

Mandrins de frettage 4,5° pour le serrage de queues d'outils carbures de type HM et HSS

**Verwendung:**

Zur Aufnahme von Werkzeugen mit Zylinderschaft.

Application:

For mounting straight-shank tools.

Application:

Pour le serrage d'outils avec queue cylindrique.

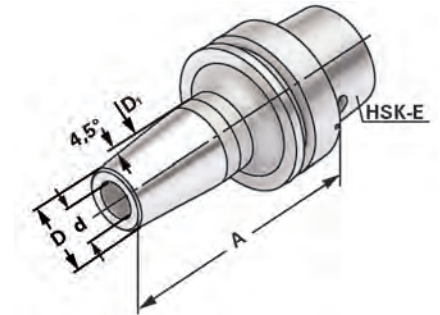
ISO 12164-1
(DIN 69893-1)

HSK - E

 $\nabla \leq 0,003$ G2,5
25.000 min⁻¹

5

Bestell-Nr. Order no. Référence	HSK	d	A	D	D ₁	l ₁	l ₂
E25.70.03	HSK-E 25	3	40	11	15	10	-
E25.70.04	HSK-E 25	4	40	16	22	20	-
E25.70.05	HSK-E 25	5	50	16	22	20	-
E25.70.06	HSK-E 25	6	50	21	26	36	-
E25.70.08	HSK-E 25	8	50	21	26	36	-
E25.70.10	HSK-E 25	10	50	21	26	42	-
E25.70.12	HSK-E 25	12	50	24	26	47	-
E32.70.03	HSK-E 32	3	70	11	15	10	-
E32.70.04	HSK-E 32	4	70	16	22	20	5
E32.70.05	HSK-E 32	5	70	16	22	20	5
E32.70.06	HSK-E 32	6	70	21	26	36	10
E32.70.08	HSK-E 32	8	70	21	26	36	10
E32.70.10	HSK-E 32	10	70	24	26	42	10
E32.70.12	HSK-E 32	12	80	24	26	47	10
E32.70.04.1	HSK-E 32	4	160	14	21	10	5
E32.70.05.1	HSK-E 32	5	160	16	24	20	5
E32.70.06.1	HSK-E 32	6	160	21	27	36	5
E32.70.08.1	HSK-E 32	8	160	21	27	36	10
E32.70.10.1	HSK-E 32	10	160	24	32	41	10
E32.70.12.1	HSK-E 32	12	160	24	32	47	10
E40.70.03	HSK-E 40	3	75	11	15	10	-
E40.70.04	HSK-E 40	4	80	16	22	20	5
E40.70.05	HSK-E 40	5	80	16	22	20	5
E40.70.06	HSK-E 40	6	80	21	27	36	10
E40.70.08	HSK-E 40	8	80	21	27	36	10
E40.70.10	HSK-E 40	10	80	24	32	42	10
E40.70.12	HSK-E 40	12	90	24	32	47	10
E40.70.14	HSK-E 40	14	90	27	34	47	10
E40.70.16	HSK-E 40	16	90	27	34	50	10

Hinweis: Aufnahme für Induktiv-, Kontakt- und Heißluftschumpfgeräte geeignet. Schafttoleranz bei Ø 3, 4 und 5 mm = h₄, bei Ø 6 – Ø 32 mm = h₆**Note:** Toolholders suitable for induction-, contact- and hot air shrink units. Ø 3, 4, 5 with h₄-tolerance and Ø 6 – Ø 32 with h₆-tolerance**Observation:** Porte-outils convenables pour machines à frotter par induction, par contact, ou par air chaud. Ø 3, 4, 5 avec h₄-tolerance et Ø 6 – Ø 32 avec h₆-tolerance

l₁ = max. Einstecktiefe
l₁ = max. clamping depth
l₁ = max. profondeur d'insertion
l₂ = max. Verstellweg
l₂ = max. length adjustment range
l₂ = max. course de réglage

zum Spannen von HM und HSS Werkzeugschäften

Shrink chucks 4,5° for mounting of solid carbide and HSS-tool shanks

Mandrins de frettage 4,5° pour le serrage de queues d'outils carbures de type HM et HSS



Verwendung:
Zur Aufnahme von Werkzeugen mit Zylinderschaft.

Application:
For mounting straight-shank tools.

Application:
Pour le serrage d'outils avec queue cylindrique.

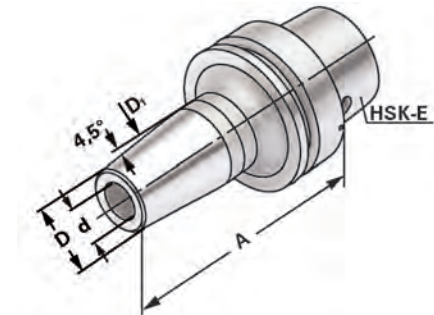
ISO 12164-1
(DIN 69893-1)

HSK - E

 $\lambda \leq 0,003$ G2,5
25.000 min⁻¹

Bestell-Nr. Order no. Référence	HSK	d	A	D	D ₁	l ₁	l ₂
E40.70.06.1	HSK-E 40	6	130	21	27	36	10
E40.70.08.1	HSK-E 40	8	130	21	27	36	10
E40.70.10.1	HSK-E 40	10	130	24	32	41	10
E40.70.12.1	HSK-E 40	12	130	24	32	47	10
E40.70.14.1	HSK-E 40	14	130	27	34	47	10
E40.70.16.1	HSK-E 40	16	130	27	34	50	10
E50.70.03	HSK-E 50	3	80	11	15	10	-
E50.70.04	HSK-E 50	4	80	16	22	20	5
E50.70.05	HSK-E 50	5	80	16	22	20	5
E50.70.06	HSK-E 50	6	80	21	27	36	10
E50.70.08	HSK-E 50	8	80	21	27	36	10
E50.70.10	HSK-E 50	10	85	24	32	42	10
E50.70.12	HSK-E 50	12	90	24	32	47	10
E50.70.14	HSK-E 50	14	90	27	34	47	10
E50.70.16	HSK-E 50	16	95	27	34	50	10
E50.70.18	HSK-E 50	18	95	33	42	50	10
E50.70.20	HSK-E 50	20	100	33	42	52	10
E50.70.03.1	HSK-E 50	3	120	11	21	10	-
E50.70.04.1	HSK-E 50	4	120	14	21	10	5
E50.70.05.1	HSK-E 50	5	120	16	24	20	5
E50.70.06.1	HSK-E 50	6	120	21	27	36	10
E50.70.08.1	HSK-E 50	8	120	21	27	36	10
E50.70.10.1	HSK-E 50	10	120	24	32	42	10
E50.70.12.1	HSK-E 50	12	120	24	32	47	10
E50.70.14.1	HSK-E 50	14	120	27	34	47	10
E50.70.16.1	HSK-E 50	16	120	27	34	50	10
E50.70.18.1	HSK-E 50	18	120	33	42	50	10
E50.70.20.1	HSK-E 50	20	120	33	42	52	10

5

Für Ø 3, 4 und 5 mm nur Hartmetallschäfte verwenden!

For Ø 3, 4 and 5 mm only solid carbide tool shanks must be used!

Pour Ø 3, 4 et 5 mm il faut seulement utiliser de queues d'outils carbures de type HM!

Hinweis: Aufnahme für Induktiv-, Kontakt- und Heißluftschumpfgeräte geeignet.
Schafttoleranz bei Ø 3, 4 und 5 mm = h₄, bei Ø 6 - Ø 32 mm = h₆

Note: Toolholders suitable for induction-, contact- and hot air shrink units.
Ø 3, 4, 5 with h₄-tolerance and Ø 6 - Ø 32 with h₆-tolerance

Observation: Porte-outils convenables pour machines à fretter par induction, par contact, ou par air chaud.
Ø 3, 4, 5 avec h₄-tolerance et Ø 6 - Ø 32 avec h₆-tolerance

l₁ = max. Einstecktiefe
l₁ = max. clamping depth
l₁ = max. profondeur d'insertion
l₂ = max. Verstellweg
l₂ = max. length adjustment range
l₂ = max. course de réglage



zum Spannen von HM und HSS Werkzeugschäften

Shrink chucks 4,5° for mounting of solid carbide and HSS-tool shanks

Mandrins de frettage 4,5° pour le serrage de queues d'outils carbures de type HM et HSS

**Verwendung:**

Zur Aufnahme von Werkzeugen mit Zylinderschaft.

Application:

For mounting straight-shank tools.

Application:

Pour le serrage d'outils avec queue cylindrique.

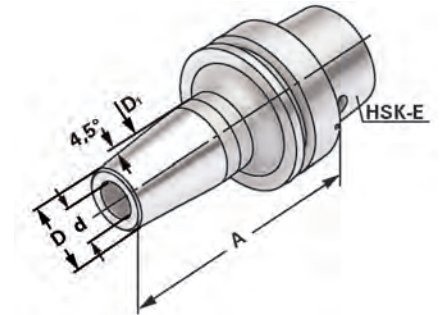
ISO 12164-1
(DIN 69893-1)

HSK - E

 $\nabla \leq 0,003$ G2,5
25.000 min⁻¹

5

Bestell-Nr.
Order no.
Référence

Bestell-Nr. Order no. Référence	HSK	d	A	D	D ₁	l ₁	l ₂
E50.70.03.2	HSK-E 50	3	160	11	21	10	-
E50.70.04.2	HSK-E 50	4	160	14	21	10	5
E50.70.05.2	HSK-E 50	5	160	16	24	20	5
E50.70.06.2	HSK-E 50	6	160	21	27	36	10
E50.70.08.2	HSK-E 50	8	160	21	27	36	10
E50.70.10.2	HSK-E 50	10	160	24	32	41	10
E50.70.12.2	HSK-E 50	12	160	24	32	47	10
E50.70.14.2	HSK-E 50	14	160	27	34	47	10
E50.70.16.2	HSK-E 50	16	160	27	34	50	10
E50.70.18.2	HSK-E 50	18	160	33	42	50	10
E50.70.20.2	HSK-E 50	20	160	33	42	52	10
E63.70.03	HSK-E 63	3	80	11	15	10	-
E63.70.04	HSK-E 63	4	80	14	22	20	5
E63.70.05	HSK-E 63	5	80	16	22	20	5
E63.70.06	HSK-E 63	6	80	21	27	36	10
E63.70.08	HSK-E 63	8	80	21	27	36	10
E63.70.10	HSK-E 63	10	85	24	32	41	10
E63.70.12	HSK-E 63	12	90	24	32	47	10
E63.70.14	HSK-E 63	14	90	27	34	47	10
E63.70.16	HSK-E 63	16	95	27	34	50	10
E63.70.18	HSK-E 63	18	95	33	42	50	10
E63.70.20	HSK-E 63	20	100	33	42	52	10
E63.70.25	HSK-E 63	25	115	44	53	58	10
E63.70.32	HSK-E 63	32	120	44	53	62	10

Für Ø 3, 4 und 5 mm nur Hartmetallschäfte verwenden!*For Ø 3, 4 and 5 mm only solid carbide tool shanks must be used!*

Pour Ø 3, 4 et 5 mm il faut seulement utiliser de queues d'outils carbures de type HM!

Hinweis: Aufnahme für Induktiv-, Kontakt- und Heißluftschumpfergeräte geeignet. Schafttoleranz bei Ø 3, 4 und 5 mm = h₄, bei Ø 6 - Ø 32 mm = h₆**Note:** Toolholders suitable for induction-, contact- and hot air shrink units. Ø 3, 4, 5 with h₄-tolerance and Ø 6 - Ø 32 with h₆-tolerance**Observation:** Porte-outils convenables pour machines à frotter par induction, par contact, ou par air chaud. Ø 3, 4, 5 avec h₄-tolerance et Ø 6 - Ø 32 avec h₆-tolerancel₁ = max. Einstecktiefel₁ = max. clamping depthl₁ = max. profondeur d'insertionl₂ = max. Verstellwegl₂ = max. length adjustment rangel₂ = max. course de réglage

5.43



10.86

zum Spannen von HM und HSS Werkzeugschäften

Shrink chucks 4,5° for mounting of solid carbide and HSS-tool shanks

Mandrins de frettage 4,5° pour le serrage de queues d'outils carbures de type HM et HSS



Verwendung:
Zur Aufnahme von Werkzeugen mit
Zylinderschaft.

Application:
For mounting straight-shank tools.

Application:
Pour le serrage d'outils avec queue
cylindrique.

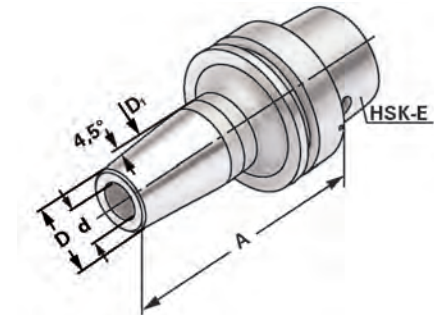
ISO 12164-1
(DIN 69893-1)

HSK - E

 $\nabla \leq 0,003$ G2,5
25.000 min⁻¹

Bestell-Nr. Order no. Référence	HSK	d	A	D	D ₁	l ₁	l ₂
E63.70.04.1	HSK-E 63	4	120	14	21	10	5
E63.70.06.1	HSK-E 63	6	120	21	27	36	10
E63.70.08.1	HSK-E 63	8	120	21	27	36	10
E63.70.10.1	HSK-E 63	10	120	24	32	41	10
E63.70.12.1	HSK-E 63	12	120	24	32	47	10
E63.70.16.1	HSK-E 63	16	120	27	34	50	10
E63.70.03.2	HSK-E 63	3	160	11	21	10	-
E63.70.04.2	HSK-E 63	4	160	14	21	10	5
E63.70.05.2	HSK-E 63	5	160	16	24	20	5
E63.70.06.2	HSK-E 63	6	160	21	27	36	10
E63.70.08.2	HSK-E 63	8	160	21	27	36	10
E63.70.10.2	HSK-E 63	10	160	24	32	41	10
E63.70.12.2	HSK-E 63	12	160	24	32	47	10
E63.70.14.2	HSK-E 63	14	160	27	34	47	10
E63.70.16.2	HSK-E 63	16	160	27	34	50	10
E63.70.18.2	HSK-E 63	18	160	33	42	50	10
E63.70.20.2	HSK-E 63	20	160	33	42	52	10
E63.70.25.2	HSK-E 63	25	160	44	42	58	10

Für Ø 3, 4 und 5 mm nur Hartmetallschäfte verwenden!

For Ø 3, 4 and 5 mm only solid carbide tool shanks must be used!

Pour Ø 3, 4 et 5 mm il faut seulement utiliser de queues d'outils carbures de type HM!

Hinweis: Aufnahme für Induktiv-, Kontakt- und Heißluftschumpfergeräte geeignet.
Schafttoleranz bei Ø 3, 4 und 5 mm = h₄, bei Ø 6 – Ø 32 mm = h₆

Note: Toolholders suitable for induction-, contact- and hot air shrink units.
Ø 3, 4, 5 with h₄-tolerance and Ø 6 – Ø 32 with h₆-tolerance

Observation: Porte-outils convenables pour machines à fretter par induction,
par contact, ou par air chaud.
Ø 3, 4, 5 avec h₄-tolerance et Ø 6 – Ø 32 avec h₆-tolerance

l₁ = max. Einstecktiefe l₂ = max. Verstellweg
l₁ = max. clamping depth l₂ = max. length adjustment range
l₁ = max. profondeur d'insertion l₂ = max. course de réglage



Toolholders DIN 69893-6 form F
Porte-outils DIN 69893-6 forme F

Vorgewuchtet
Pre-balanced
Pré-équilibré

G 6,3 15.000 min⁻¹

G 2,5 Feinwuchten gegen Aufpreis
G 2.5 Fine balancing at extra charge
G 2,5 Equilibrage fin contre un supplément

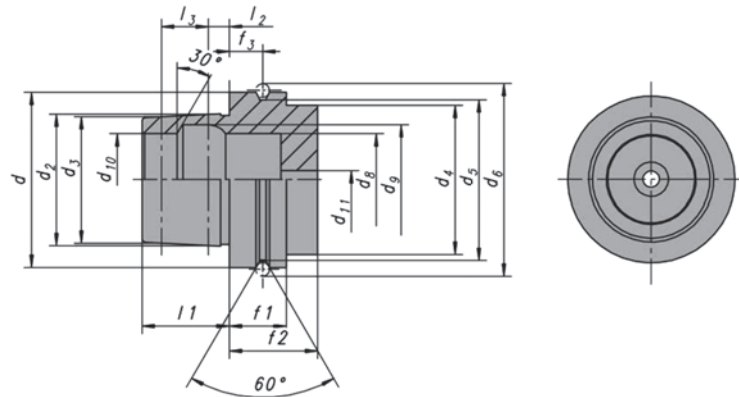

d ₁	d ₂	d ₃	d ₄	d _{5 -0,1}	d _{6 -0,1}	d _{8 H10}	d _{9 H11}	d ₁₀	f _{1 -0,1}	f _{2 min.}	f _{3 ±0,1}	l _{1 -0,2}	l ₂	l ₃	
50	30	^{+0,007} / _{+0,005}	29,05 ^{+0,005} / _{+0,003}	42	43	59,3	21	25,5	23	26	42	18	20	4	9,5
63	38	^{+0,009} / _{+0,006}	36,90 ^{+0,006} / _{+0,003}	53	55	72,3	26	32	29	26	42	18	25	5	11

5

Werkstoff: Legierter Einsatzstahl mit einer Zugfestigkeit im Kern von min. 1200 N / mm². Einsatzgehärtet HRC 60 ± 2 (HV 700 ± 50), Härtetiefe 0,8 mm ± 0,2 mm, brüniert und präzisionsgeschliffen.

Genauigkeit: Kegelwinkel – Toleranzqualität < AT 3 nach DIN 7187.

Material: *Alloyed case-hardened steel, tensile core strength of min. 1200 N / mm². Case hardened HRC 60 ± 2 (HV 700 ± 50), hardening depth 0.8 mm ± 0.2 mm, black-finished and precisely grinded.*

Accuracy: *Quality of taper < AT 3 according to DIN 7187.*

Matière: Acier de cémentation allié. Résistance à la traction dans le noyau de min 1200 N / mm². Cémentation à HRC 60 ± 2 (HV 700 ± 50), profondeur de cémentation 0,8 mm ± 0,2 mm, bruni et rectifié précisément.

Précision: Qualité du cône < AT 3 suivant DIN 7187.



Index
Table de matières

5.79	5.80	5.81	5.83
5.84	5.85	5.86	5.87
5.88	5.89	5.91	



DIN 6388 (ISO 10897) System OZ

Collet chucks for collets DIN 6388 (ISO 10897) OZ-system
Mandrins à pinces pour pinces DIN 6388 (ISO 10897) système OZ



Verwendung:
Zur Aufnahme von Werkzeugen mit Zylinderschaft in Spannzangen.
Application:
For mounting straight-shank tools in collets.
Application:
Pour le serrage d'outils avec queue cylindrique dans des pinces de serrage.

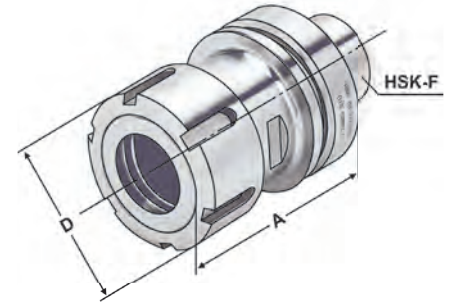

ISO 12164 (DIN 69893)	HSK - F	$\nabla \leq 0,003$	G2,5 25.000 min ⁻¹	1.4.04
--------------------------	---------	---------------------	----------------------------------	--------

Bestell-Nr. Order no. Référence	HSK	Spannbereich Capacity d Capacité	A	D
F63.01.25	HSK-F 63	2 – 25 (OZ 25)	85	60

5

Lieferumfang: Mit gewuchteter Spannmutter
Delivery: With balanced clamping nut
Livraison: Avec écrou de serrage équilibré

Gewuchtete Ausführung



Balanced type
Type équilibré

Bestell-Nr. Order no. Référence	Abmessung Size Dimension
---------------------------------------	--------------------------------

Wuchten auf G 2,5 von vorgewuchteten
Kemmler-Werkzeugen
Balancing at G 2.5 of pre-balanced Kemmler-tools
Equilibrage sur G 2,5 d'outils Kemmler pré-équilibrés

W25 Ohne Wuchtprotokoll
Without balancing report
Sans protocole d'équilibrage

W25.2 Mit Wuchtprotokoll
With balancing report
Avec protocole d'équilibrage

Wuchten von nicht vorgewuchteten Werkzeugen
Balancing of unbalanced tools
Equilibrage d'outils non-équilibrés

W25.1 Ohne Wuchtprotokoll
Without balancing report
Sans protocole d'équilibrage



DIN 6499 (ISO 15488) System ER

Collet chucks for collets DIN 6499 (ISO 15488) ER-system

Mandrins à pinces pour pinces DIN 6499 (ISO 15488) système ER

**Verwendung:**

Zur Aufnahme von Werkzeugen mit Zylinderschaft in Spannzangen.

Application:

For mounting straight-shank tools in collets.

Application:

Pour le serrage d'outils avec queue cylindrique dans des pinces de serrage.

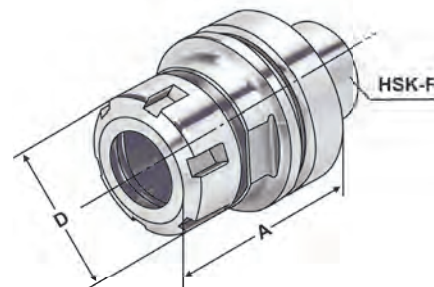
ISO 12164
(DIN 69893)

HSK - F

 $\nabla \leq 0,003$ G2,5
25.000 min⁻¹

14.04

Bestell-Nr. Order no. Référence	HSK	Spannbereich Capacity d Capacité	A	D
F40.02.10	HSK-F 40	1 - 10 (ER 16)	60	28
F40.02.16	HSK-F 40	1 - 16 (ER 25)	60	42
F50.02.16	HSK-F 50	1 - 16 (ER 25)	70	42
F50.02.20	HSK-F 50	2 - 20 (ER 32)	80	50
F50.02.26	HSK-F 50	3 - 26 (ER 40)	80	63
F63.02.10	HSK-F 63	1 - 10 (ER 16)	60	28
F63.02.16	HSK-F 63	2 - 16 (ER 25)	70	42
F63.02.20	HSK-F 63	2 - 20 (ER 32)	70	50
F63.02.26	HSK-F 63	3 - 26 (ER 40)	75	63
F63.02.10.1	HSK-F 63	1 - 10 (ER 16)	100	28
F63.02.16.1	HSK-F 63	2 - 16 (ER 25)	100	42
F63.02.20.1	HSK-F 63	2 - 20 (ER 32)	100	50
F63.02.26.1	HSK-F 63	3 - 26 (ER 40)	100	63
F63.02.10.2	HSK-F 63	1 - 10 (ER 16)	160	28
F63.02.16.2	HSK-F 63	2 - 16 (ER 25)	160	42
F63.02.20.2	HSK-F 63	2 - 20 (ER 32)	160	50
F63.02.26.2	HSK-F 63	3 - 26 (ER 40)	160	63

Lieferumfang: Mit gewuchteter Spannmutter
Delivery: With balanced clamping nut
Livraison: Avec écrou de serrage équilibré





End mill holders DIN 6359 for end mills DIN 1835-B
Porte-fraises DIN 6359 pour queues cylindriques DIN 1835-B



Verwendung:
Zum Spannen von zylindrischen
Werkzeugschäften mit seitlicher Spann-
fläche nach DIN 1835 Form B (Weldon).

Application:
For mounting straight-shank tools with flat
according to DIN 1835 form B (Weldon).

Application:
Pour le serrage d'outils avec queue
cylindrique et avec méplat suivant DIN
1835 forme B (Weldon).

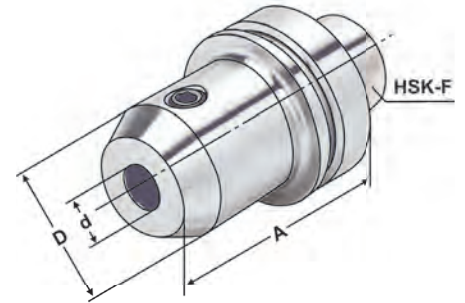

ISO 12164
(DIN 69893)

HSK - F

$\nabla \leq 0,003$

G2,5
25.000 min⁻¹

14.04

5

Bestell-Nr. Order no. Référence	HSK	d ^{H4}	A	D
F63.04.06	HSK-F 63	6	65	25
F63.04.08	HSK-F 63	8	65	28
F63.04.10	HSK-F 63	10	65	35
F63.04.12	HSK-F 63	12	80	42
F63.04.14	HSK-F 63	14	80	44
F63.04.16	HSK-F 63	16	80	48
F63.04.18	HSK-F 63	18	80	48
F63.04.20	HSK-F 63	20	80	52
F63.04.25	HSK-F 63	25	110	65
F63.04.32	HSK-F 63	32	110	72

Hinweis: Ab d = 25 mit zwei Spannschrauben
Note: From d = 25 on two clamping screws
Observation: A partir de d = 25 avec deux vis de serrage

Lieferumfang: Mit Spannschraube
Delivery: With clamping screw
Livraison: Avec vis de serrage



End mill holders DIN 6359 for end mills DIN 1835-E
Porte-fraises DIN 6359 pour queues cylindriques DIN 1835-E



Verwendung:
Zum Spannen von zylindrischen
Werkzeugschäften mit geneigter Spannflä-
che nach DIN 1835 Form E (Whistle Notch).

Application:
For mounting straight-shank tools and
inclined flat according to DIN 1835 form E
(Whistle Notch).

Application:
Pour le serrage d'outils avec queue
cylindrique et avec méplat incliné suivant
DIN 1835 forme E (Whistle Notch).

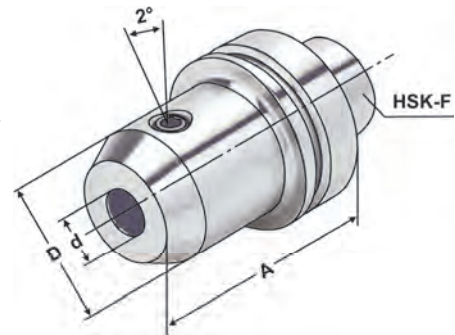

ISO 12164
(DIN 69893)

HSK - F

$\nabla \leq 0,003$

G2,5
25.000 min⁻¹

14.04

Bestell-Nr.
Order no.
Référence

HSK

d^{H4}

A

D

F63.05.06	HSK-F 63	6	100	25
F63.05.08	HSK-F 63	8	100	28
F63.05.10	HSK-F 63	10	100	35
F63.05.12	HSK-F 63	12	100	42
F63.05.14	HSK-F 63	14	100	44
F63.05.16	HSK-F 63	16	100	48
F63.05.18	HSK-F 63	18	100	48
F63.05.20	HSK-F 63	20	100	52
F63.05.25	HSK-F 63	25	120	65
F63.05.32	HSK-F 63	32	120	72

5

Hinweis: Ab d = 25 mit zwei Spannschrauben
Note: From d = 25 on two clamping screws
Observation: A partir de d = 25 avec deux vis de serrage

Lieferumfang: Mit Spannschraube und axialer Verstellechraube
Delivery: With clamping screw and axial adjustment bolt
Livraison: Avec vis de serrage et vis de butée axiale

Gewuchtete Ausführung

Balanced type
Type équilibré



Bestell-Nr. Order no. Référence	Abmessung Size Dimension
---------------------------------------	--------------------------------

**Wuchten auf G 2,5 von vorgewuchteten
Kemmler-Werkzeugen**
Balancing at G 2.5 of pre-balanced Kemmler-tools
Équilibrage sur G 2,5 d'outils Kemmler pré-équilibrés

W25 **Ohne Wuchtprotokoll**
Without balancing report
Sans protocole d'équilibrage

W25.2 **Mit Wuchtprotokoll**
With balancing report
Avec protocole d'équilibrage

Wuchten von nicht vorgewuchteten Werkzeugen
Balancing of unbalanced tools
Équilibrage d'outils non-équilibrés

W25.1 **Ohne Wuchtprotokoll**
Without balancing report
Sans protocole d'équilibrage





mit vergrößerter Anlagefläche

Shell mill holders DIN 6357 with enlarged contact face
Porte-fraises à trou lisse DIN 6357 avec face de contact élargie



Verwendung:
Zur Aufnahme von Messerköpfen und Fräsern mit Quernut.
Application:
For mounting milling cutters with transversal groove.
Application:
Pour le serrage de fraises à rainure transversale.

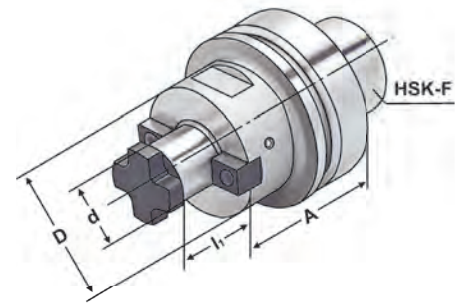

ISO 12164 (DIN 69893) HSK - F $\lambda \leq 0,005$ G2,5 25.000 min⁻¹



5

Bestell-Nr. Order no. Référence	HSK	d _{H6}	A	l ₁	D
F63.11.16	HSK-F 63	16	50	17	40
F63.11.22	HSK-F 63	22	50	19	48
F63.11.27	HSK-F 63	27	60	21	60
F63.11.32	HSK-F 63	32	60	24	78
F63.11.40	HSK-F 63	40	100	27	89
F63.11.16.1	HSK-F 63	16	100	17	40
F63.11.22.1	HSK-F 63	22	100	19	48
F63.11.27.1	HSK-F 63	27	100	21	60
F63.11.32.1	HSK-F 63	32	100	24	78
F63.11.16.2	HSK-F 63	16	160	17	40
F63.11.22.2	HSK-F 63	22	160	19	48
F63.11.27.2	HSK-F 63	27	160	21	60

d = 40: Für große Planfräser mit vier zusätzlichen Gewindebohrungen nach DIN 2079
For large diameter face mill cutters with four additional threaded holes according to DIN 2079
Pour fraises à surfacer à grands diamètres avec quatre trous taraudés additionnels suivant DIN 2079

Lieferumfang: Mit Mitnehmersteinen und Kreuzschraube.
Delivery: With drivers and cross head retaining screw.
Livraison: Avec tenons et une vis cruciforme.



CNC-Drill chucks for clockwise and counter clockwise rotation
Mandrins de perçage CNC pour rotation gauche-droite



Verwendung:
Zur Aufnahme von Werkzeugen mit Zylinderschaft.

Application:
For mounting tools with straight shanks.

Application:
Pour le serrage d'outils avec queue cylindrique.

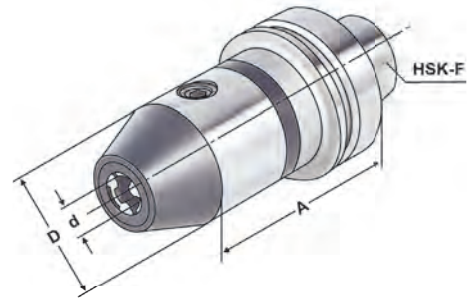

ISO 12164
(DIN 69893)

HSK - F

$\lambda \leq 0,030$

G2,5
25.000 min⁻¹

14.04

Bestell-Nr. Order no. Référence	HSK	Spannbereich Capacity Capacité	A	D
F63.15.13	HSK-F 63	1,0 – 13	110	50
F63.15.16	HSK-F 63	2,5 – 16	115	50

5

Hinweis: Hohe Präzision und Rundlaufgenauigkeit von $\leq 0,03$ mm. Sichere Spannung des Werkzeuges durch mechanische Spannkraftverstärkung. Kein selbständiges Lösen der Spannung während der Bearbeitung bei Links- oder Rechtslauf, sowie bei Spindelstop. Spannen und Lösen mit Sechskantschlüssel.

Note: *High precision and accurate concentricity of ≤ 0.03 mm. Secure gripping of the tool through mechanical amplification of the clamping force. No automatic slackening of the clamping force while machining with either clockwise or counter clockwise rotation or on spindle stop. Clamping and releasing effected by means of an Allen wrench.*

Observation: Précision élevée et exactitude de circularité de $\leq 0,03$ mm. Serrage sûr de l'outil grâce à l'amplification de la force de serrage. Pas de desserrage intempestif en cours d'usinage lors de la rotation la gauche ou la droite, de même qu'en cas d'arrêt de la broche. Serrage et desserrage en utilisant un clé sur à fourche.

Lieferumfang: Mit Spannschlüssel
Delivery: *With wrench*
Livraison: Avec clé de serrage



10.23



mit Längenausgleich auf Druck und Zug

Quick change tapping chucks with length compensation on compression and expansion

Mandrins de taraudage à changement rapide avec compensation longitudinale à la compression et traction



Verwendung:

Zur Aufnahme von Schnellwechsel-Einsätzen für Gewindebohrer.

Application:

For the chucking of quick change adaptors for taps.

Application:

Pour le serrage d'adapteurs porte-tarands à changement rapide.

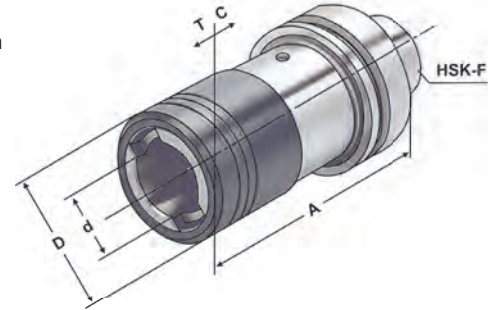

ISO 12164 (DIN 69893)	HSK - F	G2.5 25.000 min ⁻¹
--------------------------	---------	----------------------------------

Bestell-Nr. Order no. Référence	HSK	Spannbereich Capacity Capacité	Größe Size Taille	A	D	d	C	T
F63.16.12	HSK-F 63	M3 – M14	1	102	36	19	7	7
F63.16.20	HSK-F 63	M5 – M22	2	140	53	31	12	12



Hinweis: Für Bearbeitungszentren ohne Synchronspindel.
Note: For machining centres without synchronous spindle.
Observation: Pour centres d'usinage sans broche synchrone.





Adaptor sleeves for MT with tang DIN 6383
 Douilles de réduction pour CM à tenon DIN 6383



Verwendung:
 Zur Aufnahme von Werkzeugen mit Morsekegelschaft und Austreibblappen nach DIN 228-1 Form B.

Application:
 For mounting tools with Morse taper shank and tang according to DIN 228-1 form B.

Application:
 Pour le serrage d'outils avec queue cône Morse et tenon suivant DIN 228-1 forme B.

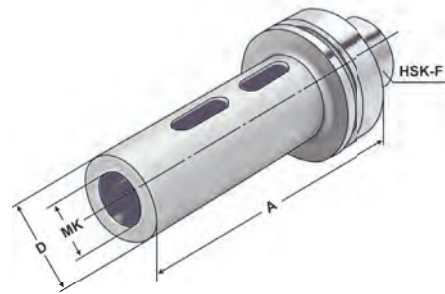

ISO 12164 (DIN 69893) HSK - F $\nabla \leq 0,005$ G2,5 25.000 min⁻¹

Bestell-Nr. Order no. Référence	HSK	MK MT CM	A	D
F63.07.01	HSK-F 63	1	100	25
F63.07.02	HSK-F 63	2	120	32
F63.07.03	HSK-F 63	3	140	40
F63.07.04	HSK-F 63	4	160	48





Boring bar blanks
Barres d'alésage



Verwendung:
Zur Herstellung von Sonderwerkzeugen.
Application:
For the manufacturing of special tools.
Application:
Pour la fabrication d'outils spéciaux.

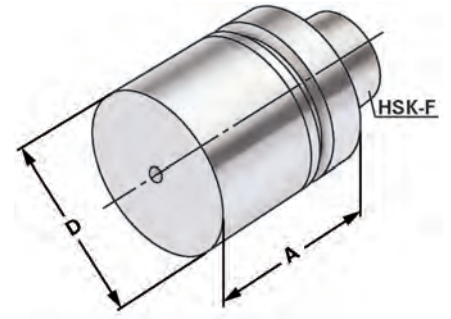

ISO 12164
(DIN 69893)

HSK - F

Bestell-Nr.
Order no.
Référence

HSK

A

D

F63.17.63

HSK-F 63

125

63

F63.17.63.1

HSK-F 63

250

63

5

Ausführung: Kegel und Bund gehärtet und geschliffen. Schaft weich zur weiteren Bearbeitung.
Version: *Cone and flange hardened and adjusted. Soft body for later processing.*
Version: Cône et collerette durcis et rectifiés. Corps doux pour un usinage ultérieur.



Test arbors
Mandrins de contrôle



Verwendung:
Zur Abnahme von Werkzeugmaschinen gemäß ISO-Empfehlung R230 oder zur Überprüfung der Werkzeugspindel.

Application:
For the inspection of machine tools according to ISO recommendation R230 or for testing the tool spindle.

Application:
Pour l'inspection de machine-outils suite à la recommandation ISO R230 ou pour la vérification de la broche.

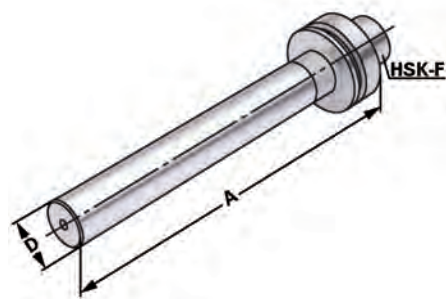

ISO 12164 (DIN 69893) HSK - F $\nabla \leq 0,003$

Bestell-Nr. Order no. Référence	HSK	A	D	Toleranz Tolerance Tolérance	max. Rundlaufabweichung max. concentricity deviation Faux-rond max.
F63.18.40	HSK-F 63	250	40	0,003	0,003



Lieferumfang: Auslieferung mit Prüfprotokoll
Delivery: Delivery with test certificate
Livraison: Livraison avec rapport d essais

Holzkasten für Kontrolldorne

Wooden box for test arbors
Coffret en bois pour mandrins de contrôle



Verwendung:
Zur Aufbewahrung von Kontrolldornen.

Application:
For the storage of test arbors.

Application:
Pour la conservation de mandrins de contrôle.



Bestell-Nr. Order no. Référence	Abmessung Size Dimension	für Kegelgrößen for cones pour cônes
701.18	460 × 130 × 115	HSK 32 / 40 / 50 / 63 / 80 / 100



zum Spannen von HM und HSS Werkzeugschäften

Shrink chucks 4,5° for mounting of solid carbide and HSS-tool shanks

Mandrins de frettage 4,5° pour le serrage de queues d'outils carbures de type HM et HSS

**Verwendung:**

Zur Aufnahme von Werkzeugen mit Zylinderschaft.

Application:

For mounting straight-shank tools.

Application:

Pour le serrage d'outils avec queue cylindrique.

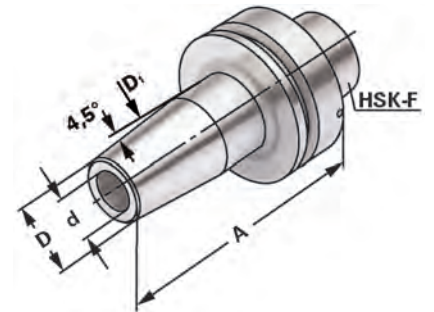
ISO 12164
(DIN 69893)

HSK - F

 $\nabla \leq 0,003$ G2,5
25.000 min⁻¹

5

Bestell-Nr. Order no. Référence	HSK	d	A	D	D ₁	l ₁	l ₂
F63.70.03	HSK-F 63	3	80	11	15	10	-
F63.70.04	HSK-F 63	4	80	14	22	20	5
F63.70.05	HSK-F 63	5	80	16	22	20	5
F63.70.06	HSK-F 63	6	80	21	27	36	10
F63.70.08	HSK-F 63	8	80	21	27	36	10
F63.70.10	HSK-F 63	10	85	24	32	42	10
F63.70.12	HSK-F 63	12	90	24	32	47	10
F63.70.14	HSK-F 63	14	95	27	34	47	10
F63.70.16	HSK-F 63	16	95	27	34	50	10
F63.70.18	HSK-F 63	18	95	33	42	50	10
F63.70.20	HSK-F 63	20	100	33	42	52	10
F63.70.25	HSK-F 63	25	115	44	54	58	10
F63.70.03.1	HSK-F 63	3	120	11	15	10	-
F63.70.04.1	HSK-F 63	4	120	16	22	20	5
F63.70.05.1	HSK-F 63	5	120	16	22	20	5
F63.70.06.1	HSK-F 63	6	120	21	27	36	10
F63.70.08.1	HSK-F 63	8	120	21	27	36	10
F63.70.10.1	HSK-F 63	10	120	24	32	42	10
F63.70.12.1	HSK-F 63	12	120	24	32	47	10
F63.70.14.1	HSK-F 63	14	120	27	34	47	10
F63.70.16.1	HSK-F 63	16	120	27	34	50	10
F63.70.18.1	HSK-F 63	18	120	33	42	50	10

Für Ø 3, 4 und 5 mm nur Hartmetallschäfte verwenden!*For Ø 3, 4 and 5 mm only solid carbide tool shanks must be used!*

Pour Ø 3, 4 et 5 mm il faut seulement utiliser de queues d'outils carbures de type HM!

Hinweis: Aufnahme für Induktiv-, Kontakt- und Heißluftschumpfgeräte geeignet. Schafttoleranz bei Ø 3, 4 und 5 mm = h₄, bei Ø 6 – Ø 32 mm = h₆**Note:** Toolholders suitable for induction-, contact- and hot air shrink units. Ø 3, 4, 5 with h₄-tolerance and Ø 6 – Ø 32 with h₆-tolerance**Observation:** Porte-outils convenables pour machines à fretter par induction, par contact, ou par air chaud. Ø 3, 4, 5 avec h₄-tolerance et Ø 6 – Ø 32 avec h₆-tolerancel₁ = max. Einstecktiefel₂ = max. Verstellwegl₁ = max. clamping depthl₂ = max. length adjustment rangel₁ = max. profondeur d'insertionl₂ = max. course de réglage

5.43

10.86

zum Spannen von HM und HSS Werkzeugschäften

Shrink chucks 4,5° for mounting of solid carbide and HSS-tool shanks

Mandrins de frettage 4,5° pour le serrage de queues d'outils carbures de type HM et HSS



Verwendung:
Zur Aufnahme von Werkzeugen mit
Zylinderschaft.

Application:
For mounting straight-shank tools.

Application:
Pour le serrage d'outils avec queue
cylindrique.

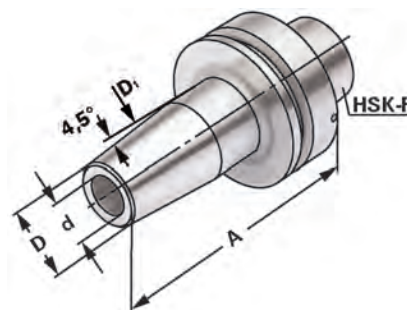
ISO 12164
(DIN 69893)

HSK - F

 $\lambda \leq 0,003$ G2,5
25.000 min⁻¹

Bestell-Nr. Order no. Référence	HSK	d	A	D	D ₁	l ₁	l ₂
F63.70.04.2	HSK-F 63	4	160	16	22	20	5
F63.70.05.2	HSK-F 63	5	160	16	22	20	5
F63.70.06.2	HSK-F 63	6	160	21	27	36	10
F63.70.08.2	HSK-F 63	8	160	21	27	36	10
F63.70.10.2	HSK-F 63	10	160	24	32	42	10
F63.70.12.2	HSK-F 63	12	160	24	32	47	10
F63.70.14.2	HSK-F 63	14	160	27	34	47	10
F63.70.16.2	HSK-F 63	16	160	27	34	50	10
F63.70.18.2	HSK-F 63	18	160	33	42	50	10
F63.70.20.2	HSK-F 63	20	160	33	42	52	10

5

Für Ø 3, 4 und 5 mm nur Hartmetallschäfte verwenden!

For Ø 3, 4 and 5 mm only solid carbide tool shanks must be used!

Pour Ø 3, 4 et 5 mm il faut seulement utiliser de queues d'outils carbures de type HM!

Hinweis: Aufnahme für Induktiv-, Kontakt- und Heißluftschumpfgeräte geeignet.
Schafttoleranz bei Ø 3, 4 und 5 mm = h₄, bei Ø 6 – Ø 32 mm = h₆

Note: Toolholders suitable for induction-, contact- and hot air shrink units.
Ø 3, 4, 5 with h₄-tolerance and Ø 6 – Ø 32 with h₆-tolerance

Observation: Porte-outils convenables pour machines à fretter par induction,
par contact, ou par air chaud.
Ø 3, 4, 5 avec h₄-tolerance et Ø 6 – Ø 32 avec h₆-tolerance

l₁ = max. Einstecktiefel₂ = max. Verstellwegl₁ = max. clamping depthl₂ = max. length adjustment rangel₁ = max. profondeur d'insertion l₂ = max. course de réglage

5.43



10.86



Hydraulic expansion chucks
Mandrins expansibles hydrauliques



Verwendung:
Zur Aufnahme von Werkzeugen mit Zylinderschaft nach DIN 1835 Form A+B+E und DIN 6535 Form HA+HB+HE (größer Ø 20 mm nur mit Reduzierung).

Application:
For mounting straight-shank tools acc. DIN 1835 form A+B+E and DIN 6535 form HA+HB+HE (larger).

Application:
Pour le serrage d'outils avec queue cylindrique suivant DIN 1835 forme A+B+E et DIN 6535 forme HA+HB+HE (à partir de dia. 20 mm seulement avec réduction).

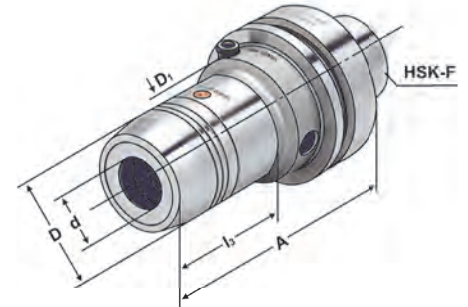

ISO 12164 (DIN 69893)	HSK - F	$\nabla \leq 0,003$	G2,5 25.000 min ⁻¹	14.04
-----------------------	---------	---------------------	-------------------------------	-------

5

Bestell-Nr. Order no. Référence	HSK	d	A	D	D ₁	l ₁	l ₂	l ₃
F63.H06	HSK-F 63	6	100	26	50	37	10	45
F63.H08	HSK-F 63	8	100	28	50	37	10	44
F63.H10	HSK-F 63	10	100	30	50	42	10	46
F63.H12	HSK-F 63	12	100	32	50	47	10	45,5
F63.H14	HSK-F 63	14	100	34	50	47	10	44
F63.H16	HSK-F 63	16	100	38	50	52	10	44
F63.H18	HSK-F 63	18	100	40	50	52	10	42
F63.H20	HSK-F 63	20	100	42	50	52	10	42
F63.H25	HSK-F 63	25	120	50	50	58	10	26
F63.H32	HSK-F 63	32	125	60	50	62	10	26

Lieferumfang: Mit Spannschlüssel
Delivery: With wrench
Livraison: Avec clé de serrage

l₁ = max. Einstecktiefe
l₁ = max. clamping depth
l₁ = max. profondeur d'insertion
l₂ = max. Verstellweg
l₂ = max. length adjustment range
l₂ = max. course de réglage

Gewuchtete Ausführung



Balanced type
Type équilibré

Bestell-Nr. Order no. Référence	Abmessung Size Dimension
---------------------------------------	--------------------------------

Wuchten auf G 2,5 von vorgewuchteten Kemmler-Werkzeugen
Balancing at G 2.5 of pre-balanced Kemmler-tools
Équilibrage sur G 2,5 d'outils Kemmler pré-équilibrés

W25 **Ohne Wuchtprotokoll**
Without balancing report
Sans protocole d'équilibrage

W25.2 **Mit Wuchtprotokoll**
With balancing report
Avec protocole d'équilibrage

Wuchten von nicht vorgewuchteten Werkzeugen
Balancing of unbalanced tools
Équilibrage d'outils non-équilibrés

W25.1 **Ohne Wuchtprotokoll**
Without balancing report
Sans protocole d'équilibrage





Technische Datenblätter, STEP/STL Modelle für die Simulation der NC-Programme und DXF-Zeichnungen zur Erstellung des Einrichteblattes stehen Online zur Verfügung.

Technical data sheets, STEP/STL models for the simulation of NC programs and DXF drawings to create the tooling sheet are online available.

Fiches techniques, STEP/STL modèles techniques pour la simulation de programmes CN et dessins DXF pour créer la feuille d'installation sont disponible online.

Sie können unsere Kataloge entweder direkt im Browser betrachten oder sie auf Ihren PC, Smartphone oder Tablet herunterladen (PDF-Reader notwendig).

You can view our catalogues either directly in the browser or download to your PC, smartphone or tablet (PDF reader required).

Vous pouvez consulter nos catalogues directement dans le navigateur ou télécharger sur votre PC, smartphone ou tablet (lecteur PDF requis).



Auf unserer Internetseite können Sie die Lagerverfügbarkeit prüfen - auch auf Mobilgeräten.

On our website you can check the stock availability - also on mobile devices.

Vous pouvez également vérifier la disponibilité de nos produits sur le site Internet - ainsi que sur vos appareils

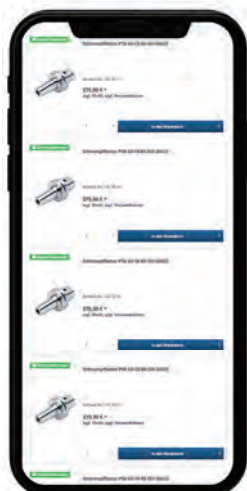

*WERKZEUGAUFNAHMEN
MIT POLYGONALSCHAFT
ISO 26623-1*

*TOOLHOLDERS
POLYGONAL SHANK
ISO 26623-1*

*PORTE-OUTILS
À QUEUE POLYGONALE
ISO 26623-1*

ISO 26623-1

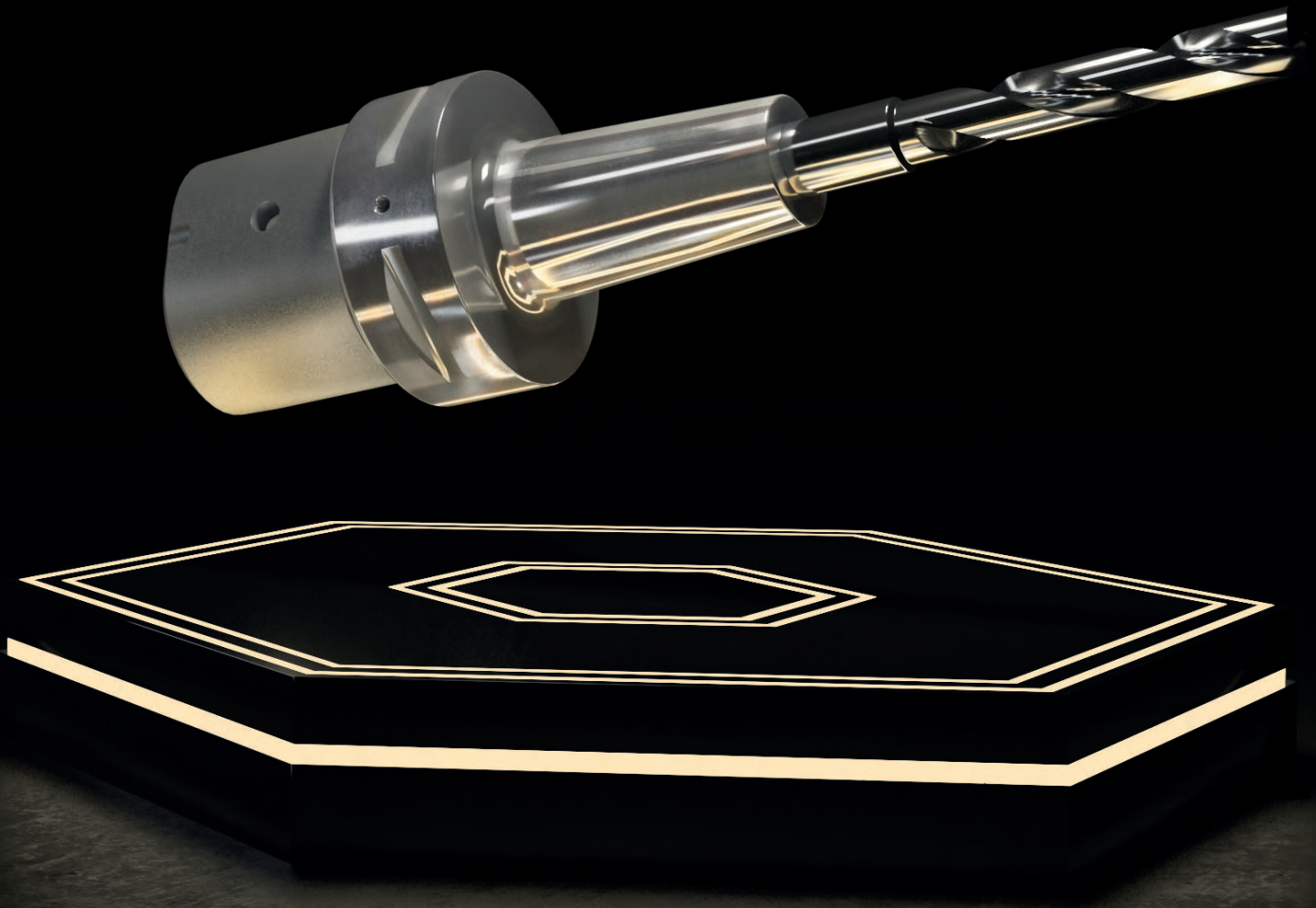

Toolholders with polygonal shank ISO 26623-1
Porte-outils à queue polygonale ISO 26623-1

Vorgewuchtet
 Pre-balanced
 Pré-équilibré

G 2,5 25.000 min⁻¹

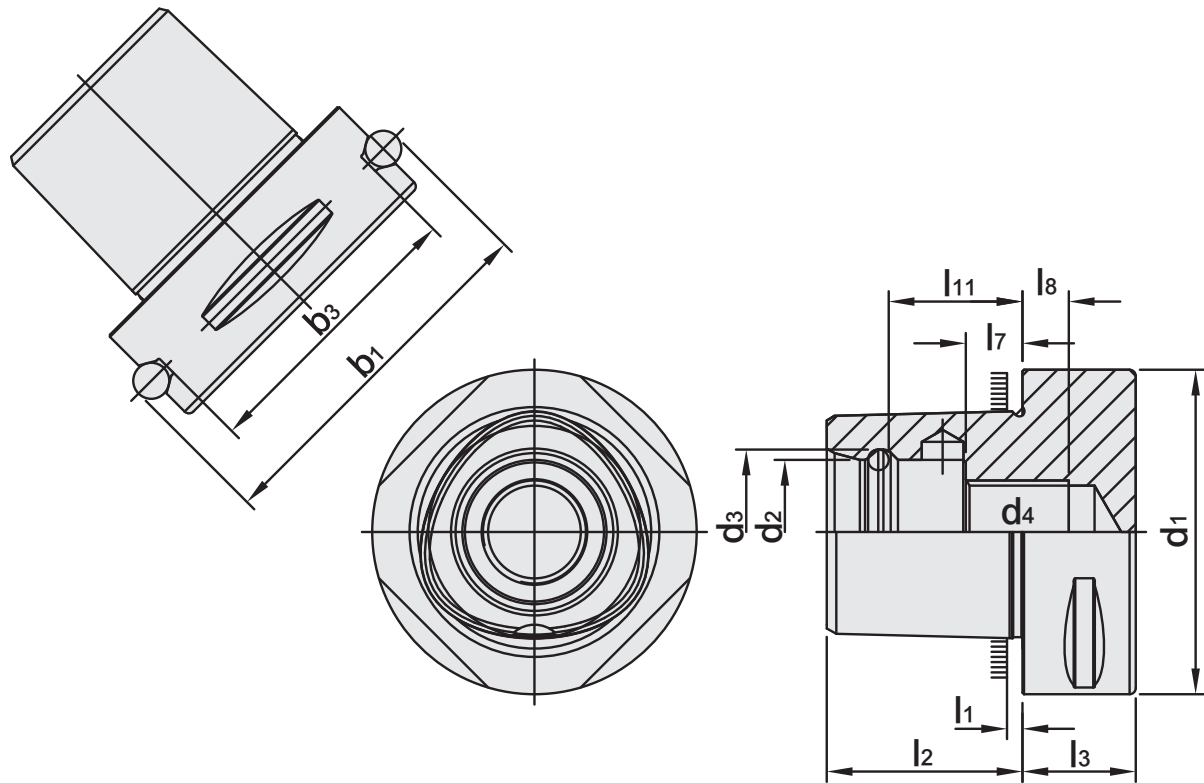

6

PSK	b ₁	b ₃	d ₁	d ₂	d ₃	d ₄	l ₁	l ₂	l ₃	l ₇	l ₈	l ₁₁
32	39	27,9	32	15	16,5	M12 x 1,5P	2,5	19	15	6	6	13,5
40	46	34,9	40	18	20	M14 x 1,5P	2,5	24	20	9	6	17,5
50	59,3	44	50	21	24	M16 x 1,5P	3	30	20	10	7	22
63	70,7	55,4	63	28	32	M20 x 2,0P	3	38	22	11	9	26
80	86	70,7	80	32	38	M20 x 2,0P	3	48	30	20	0	34

Werkstoff: Legierter Einsatzstahl mit einer Zugfestigkeit im Kern von min. 1000 N / mm². Einsatzgehärtet HRC 60 ± 2 (HV 700 ± 50), Härtetiefe 0,8 mm ± 0,2 mm, brüniert und präzisionsgeschliffen.

Material: Alloyed case-hardened steel, tensile core strength of min. 1000 N / mm². Case hardened HRC 60 ± 2 (HV 700 ± 50), hardening depth 0.8 mm ± 0.2 mm, black-finished and precisely grinded.

Matière: Acier de cémentation allié. Résistance à la traction dans le noyau de min 1000 N / mm². Cémentation à HRC 60 ± 2 (HV 700 ± 50), profondeur de cémentation 0,8 mm ± 0,2 mm, bruni et rectifié précisément.



Index
Sommaire

6.05	6.06	6.07	6.08
6.09	6.10	6.11	6.12
6.13	6.15	6.16	



DIN 6499 (ISO 15488) System ER

Collet chucks for collets DIN 6499 (ISO 15488) ER-system

Mandrins à pinces pour pinces DIN 6499 (ISO 15488) système ER

**Verwendung:**

Zur Aufnahme von Werkzeugen mit Zylinderschaft in Spannzangen.

Application:

For mounting straight-shank tools in collets.

Application:

Pour le serrage d'outils avec queue cylindrique dans des pinces de serrage.

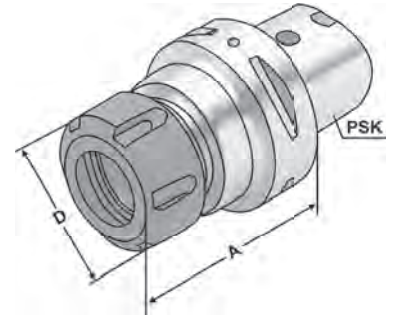

ISO 26623

 $\nearrow \leq 0,003$ G2.5
25.000 min⁻¹

14.04

6

Bestell-Nr. Order no. Référence	PSK	Spannbereich Capacity Capacité	A	D
C3.02.10 *	C3	1 – 10 (ER 16)	45	28
C3.02.13	C3	2 – 13 (ER 20)	45	34
C4.02.10 *	C4	1 – 10 (ER 16)	70	28
C4.02.13	C4	2 – 13 (ER 20)	52	34
C4.02.16	C4	2 – 16 (ER 25)	52	42
C4.02.20	C4	2 – 20 (ER 32)	54	50
C5.02.10.1 *	C5	1 – 10 (ER 16)	100	28
C5.02.13	C5	2 – 13 (ER 20)	55	34
C5.02.13.1 *	C5	2 – 13 (ER 20)	100	34
C5.02.16	C5	2 – 16 (ER 25)	55	42
C5.02.20	C5	2 – 20 (ER 32)	57	50
C5.02.20.1	C5	2 – 20 (ER 32)	100	50
C6.02.16	C6	2 – 16 (ER 25)	60	42
C6.02.20	C6	2 – 20 (ER 32)	70	50
C6.02.26	C6	3 – 26 (ER 40)	65	63
C6.02.10.1 *	C6	1 – 10 (ER 16)	100	28
C6.02.16.1	C6	2 – 16 (ER 25)	100	42
C6.02.20.1	C6	2 – 20 (ER 32)	100	50

*** Sechskantmutter**

* Hexagonal clamping nut

* Écrous hexagonal

Lieferumfang: Mit gewuchteter Spannmutter
Delivery: With balanced clamping nut
Livraison: Avec écrou de serrage équilibré





High Performance Milling Chuck HKS-system
Mandrin de serrage à haute performance système HKS



Verwendung:
Zur Aufnahme von Werkzeugen mit Zylinderschaft nach DIN 1835 Form A+B+E und DIN 6535 Form HA+HB+HE (größer Ø 20 mm nur mit Reduzierung).

Application:
For mounting straight-shank tools acc. DIN 1835 form A+B+E and DIN 6535 form HA+HB+HE (larger than dia. 20 mm only with reduction sleeve).

Application:
Pour le serrage d'outils avec queue cylindrique suivant DIN 1835 forme A+B+E et DIN 6535 forme HA+HB+HE.

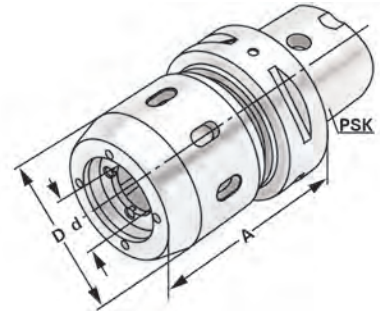

ISO 26623 $\nabla \leq 0,003$ $G2,5$ 25.000 min⁻¹ ⓘ 14.04

Bestell-Nr. Order no. Référence	PSK	Spannbereich Capacity Capacité	A	D	d
C5.64.20	C5	20 (HKS 20)	75	56	20
C5.64.32	C5	32 (HKS 32)	90	71	32
C6.64.20	C6	20 (HKS 20)	75	56	20
C6.64.32	C6	32 (HKS 32)	85	71	32



Gewuchtete Ausführung

Balanced type
Type équilibré



Bestell-Nr. Order no. Référence	Abmessung Size Dimension
---------------------------------------	--------------------------------

Wuchten auf G 2,5 von vorgewuchteten Kemmler-Werkzeugen
Balancing at G 2.5 of pre-balanced Kemmler-tools
Équilibrage sur G 2,5 d'outils Kemmler pré-équilibrés

W25 **Ohne Wuchtprotokoll**
Without balancing report
Sans protocole d'équilibrage

W25.2 **Mit Wuchtprotokoll**
With balancing report
Avec protocole 'équilibrage

Wuchten von nicht vorgewuchteten Werkzeugen
Balancing of unbalanced tools
Équilibrage d'outils non-équilibrés

W25.1 **Ohne Wuchtprotokoll**
Without balancing report
Sans protocole d'équilibrage



End mill holders DIN 6359 for end mills DIN 1835-B
 Porte-fraises DIN 6359 pour queues cylindriques DIN 1835-B



Verwendung:
 Zum Spannen von zylindrischen Werkzeugschäften mit seitlicher Spannfläche nach DIN 1835 Form B (Weldon).

Application:
 For mounting straight-shank tools with lateral flat according to DIN 1835 form B (Weldon).

Application:
 Pour le serrage d'outils avec queue cylindrique et avec méplat suivant DIN 1835 forme B (Weldon).

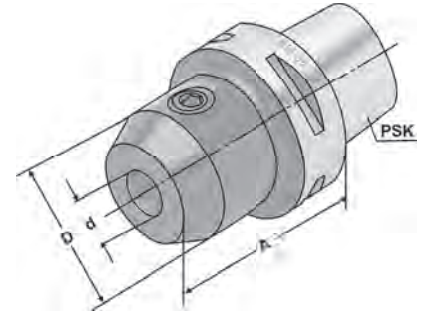

ISO 26623 $\nabla \leq 0,003$ G2,5 25.000 min⁻¹ ⓘ 14.04

6

Bestell-Nr. Order no. Référence	PSK	d ^{H4}	A	D
C3.04.06	C3	6	45	25
C3.04.08	C3	8	45	28
C3.04.10	C3	10	50	35
C3.04.12	C3	12	55	42
C4.04.06	C4	6	50	25
C4.04.08	C4	8	50	28
C4.04.10	C4	10	50	35
C4.04.12	C4	12	55	42
C4.04.14	C4	14	55	44
C4.04.16	C4	16	55	48
C5.04.06	C5	6	50	25
C5.04.08	C5	8	50	28
C5.04.10	C5	10	55	35
C5.04.12	C5	12	60	42
C5.04.14	C5	14	60	44
C5.04.16	C5	16	60	48
C5.04.18	C5	18	60	50
C5.04.20	C5	20	60	52
C5.04.25	C5	25	80	65
C6.04.06	C6	6	55	25
C6.04.08	C6	8	55	28
C6.04.10	C6	10	60	35
C6.04.12	C6	12	60	42
C6.04.14	C6	14	60	44
C6.04.16	C6	16	65	48
C6.04.18	C6	18	65	50
C6.04.20	C6	20	65	52
C6.04.25	C6	25	80	65
C6.04.32	C6	32	90	72
C6.04.40	C6	40	100	80

Lieferumfang: Mit Spannschraube
Delivery: With clamping screw
Livraison: Avec vis de serrage

Hinweis: Ab d = 25 mit zwei Spannschrauben
Note: From d = 25 on two clamping screws
Observation: A partir de d = 25 avec deux vis de serrage



Anlagefläche und Kühlkanalbohrungen an der Stirnseite

Shell mill holders DIN 6357 with enlarged contact face and coolant exit bores on the end face
 Porte-fraises à trou lisse DIN 6357 avec face de contact élargie et conduits pour l'arrosage frontal



Verwendung:
 Zur Aufnahme von Messerköpfen und Fräsern mit Quernut.
Application:
 For mounting milling cutters with transversal groove.
Application:
 Pour le serrage de fraises à rainure transversale.

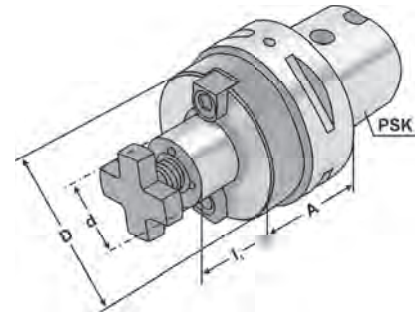

ISO 26623 $\nabla \leq 0,005$ G2,5 25.000 min⁻¹

Bestell-Nr. Order no. Référence	PSK	d _{H6}	A	l ₁	D
C3.11.16	C3	16	30	17	38
C4.11.16	C4	16	35	17	38
C4.11.22	C4	22	40	19	48
C5.11.16	C5	16	35	17	38
C5.11.22	C5	22	40	19	48
C5.11.27	C5	27	40	21	58
C5.11.32	C5	32	40	24	78
C6.11.16	C6	16	35	17	38
C6.11.22	C6	22	40	19	48
C6.11.27	C6	27	40	21	58
C6.11.32	C6	32	40	24	78
C6.11.40	C6	40	45	27	88



- d = 40/d = 60:** Für große Planfräser mit vier zusätzlichen Gewindebohrungen nach DIN 2079.
 For large diameter face mill cutters with four additional threaded holes according to DIN 2079.
 Pour fraises à surfacer à grands diamètres avec quatre trous taraudés additionnels suivant DIN 2079.
- Lieferumfang:** Mit Mitnehmersteinen, Kreuzschraube und Zylinderkopfschraube nach DIN 912 für Fräser mit innerer Kühlmittelzufuhr. Bei d = 60 nur mit vier Befestigungsschrauben nach DIN 912.
- Delivery:** With drivers, cross head retaining screw and cylinder head retaining screw for cutters with central coolant. For d = 60 only with four fixation screws according to DIN 912.
- Livraison:** Avec tenons, une vis cruciforme et une vis à tête cylindrique suivant DIN 912 pour fraises avec arrosage central. Pour d = 60 seulement avec quatre vis de fixation suivant DIN 912.





CNC-Drill chucks for clockwise and counter clockwise rotation
Mandrins de perçage CNC pour rotation gauche-droite



Verwendung:
Zur Aufnahme von Werkzeugen mit Zylinderschaft.

Application:
For mounting tools with straight shanks.

Application:
Pour le serrage d'outils avec queue cylindrique.

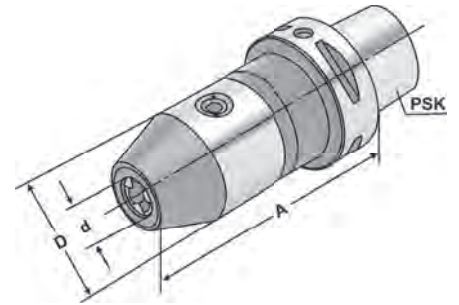

ISO 26623 $\nearrow \leq 0,003$ G2,5 25.000 min⁻¹ ⓘ 14.04

Bestell-Nr. Order no. Référence	PSK	Spannbereich Capacity Capacité	A	D
C6.15.13	C6	1,0 – 13	104	50
C6.15.16	C6	2,5 – 16	109	50



Mit zentraler Kühlmittelzufuhr
With centre coolant
Avec alimentation de liquide de refroidissement par la centre

Hinweis: Hohe Präzision und Rundlaufgenauigkeit von $\leq 0,03$ mm. Sichere Spannung des Werkzeuges durch mechanische Spannkraftverstärkung. Kein selbständiges Lösen der Spannung während der Bearbeitung bei Links- oder Rechtslauf, sowie bei Spindelstop. Spannen und Lösen mit Sechskantschlüssel.

Note: High precision and accurate concentricity of ≤ 0.03 mm. Secure gripping of the tool through mechanical amplification of the clamping force. No automatic slacking of the clamping force while machining with either clockwise or counter clockwise rotation or on spindle stop. Clamping and releasing effected by means of an Allen wrench.

Observation: Précision élevée et exactitude de circularité de $\leq 0,03$ mm. Serrage sûr de l'outil grâce à l'amplification de la force de serrage. Pas de desserrage intempestif en cours d'usinage lors de la rotation la gauche ou la droite, de même qu'en cas d'arrêt de la broche. Serrage et desserrage en utilisant un clé sur à fourche.

Lieferumfang: Mit Spannschlüssel
Delivery: With wrench
Livraison: Avec clé de serrage

Gewuchtete Ausführung



**Balanced type
Type équilibré**

Bestell-Nr. Order no. Référence	Abmessung Size Dimension
---------------------------------------	--------------------------------

Wuchten auf G 2,5 von vorgewuchteten Kemmler-Werkzeugen
Balancing at G 2.5 of pre-balanced Kemmler-tools
Équilibrage sur G 2,5 d'outils Kemmler pré-équilibrés

W25 **Ohne Wuchtprotokoll**
Without balancing report
Sans protocole d'équilibrage

W25.2 **Mit Wuchtprotokoll**
With balancing report
Avec protocole d'équilibrage

Wuchten von nicht vorgewuchteten Werkzeugen
Balancing of unbalanced tools
Équilibrage d'outils non-équilibrés

W25.1 **Ohne Wuchtprotokoll**
Without balancing report
Sans protocole d'équilibrage





auf Druck und Zug

Quick change tapping chucks with length compensation on compression and expansion
 Mandrins de taraudage à changement rapide avec compensation longitudinale
 à la compression et traction



Verwendung:
 Zur Aufnahme von Schnellwechsel-Einsätzen für Gewindebohrer.

Application:
 For the chucking of quick change adaptors for taps.

Application:
 Pour le serrage d'adapteurs portetarauds à changement rapide.

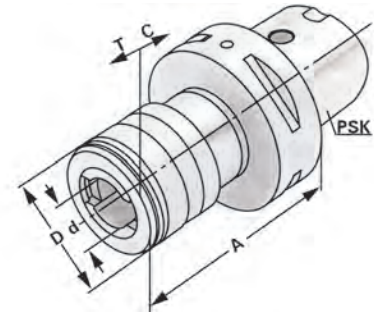

ISO 26623 G2,5 25.000 min⁻¹



Bestell-Nr. Order no. Référence	PSK	Spannbereich Capacity Capacité	Größe Size Taille	A	D	d	T	C
C4.16.12	C4	M3 - M14	1	68	41	19	7,5	7,5
C4.16.20	C4	M5 - M22	2	91	60	31	10	10
C5.16.12	C5	M3 - M14	1	68	41	19	7,5	7,5
C5.16.20	C5	M5 - M22	2	91	60	31	10	10
C6.16.12	C6	M3 - M14	1	73	41	19	7,5	7,5
C6.16.20	C6	M5 - M22	2	97	60	31	10	10
C6.16.36	C6	M14 - M36	3	146	86	48	17,5	17,5



Hinweis: Für Bearbeitungszentren ohne Synchronspindel.
Note: For machining centres without synchronous spindle.
Observation: Pour centres d'usinage sans broche synchrone.



Boring bar blanks
Barres d'alésage



Verwendung:
Zur Herstellung von Sonderwerkzeugen.
Application:
For the manufacturing of special tools.
Application:
Pour la fabrication d'outils spéciaux.

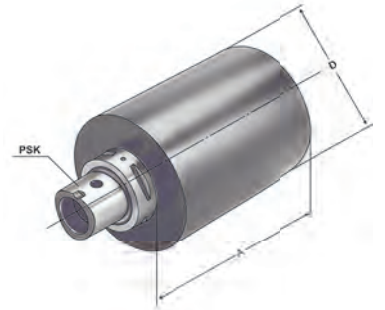

ISO 26623

Bestell-Nr. Order no. Référence	PSK	D	A
C3.17.32	C3	32	90
C3.17.60	C3	60	90
C4.17.40	C4	40	120
C4.17.80	C4	80	120
C5.17.50	C5	50	150
C5.17.95	C5	95	150
C6.17.63	C6	63	180
C6.17.120	C6	120	180

Ausführung: Kegel und Bund gehärtet und geschliffen. Schaft weich zur weiteren Bearbeitung.
Version: *Cone and flange hardened and grinded. Soft body for later processing.*
Version: Cône et collerette durcis et rectifiés. Corps doux pour un usinage ultérieur.

Test arbors
Mandrins de contrôle



Verwendung:
Zur Abnahme von Werkzeugmaschinen gemäß ISO-Empfehlung R230 oder zur Überprüfung der Werkzeugspindel.

Application:
For the inspection of machine tools according to ISO recommendation R230 or for testing the tool spindle.

Application:
Pour l'inspection de machine-outils suite à la recommandation ISO R230 ou pour la vérification de la broche.

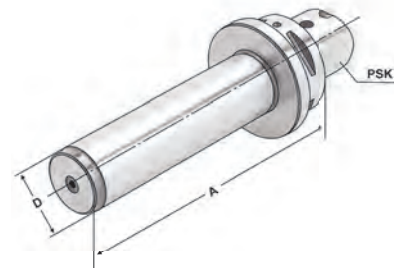

ISO 26623 $\nabla \leq 0,003$ $G2,5$
25.000 min⁻¹

Bestell-Nr. Order no. Référence	PSK	A	D	Toleranz Tolerance Tolérance	max. Rundlaufabweichung max. concentricity deviation Faux-rond max.
C3.18.20	C3	180	20	0,003	0,003
C4.18.32	C4	180	32	0,003	0,003
C5.18.32	C5	180	32	0,003	0,003
C6.18.40	C6	182	40	0,003	0,003

Lieferumfang: Auslieferung mit Prüfprotokoll
Delivery: *Delivery with test certificate*
Livraison: Livraison avec rapport d'essais



Holzkasten für Kontrolldorne

Wooden box for test arbors
Coffret en bois pour mandrins de contrôle



Verwendung:
Zur Aufbewahrung von Kontrolldornen.

Application:
For the storage of test arbors.

Application:
Pour la conservation de mandrins de contrôle.



Bestell-Nr. Order no. Référence	Abmessung Size Dimension	für Kegelgrößen for cones pour cônes
701.18	460 × 130 × 115	SK 30 / 40 / 50 / C3 / C4 / C5 / C6



Shrink chucks 4,5°
Mandrins de frettage 4,5°



Verwendung:
Zur Aufnahme von Werkzeugen mit
Zylinderschaft.

Application:
For mounting straight-shank tools.

Application:
Pour le serrage d'outils avec queue cylindrique.

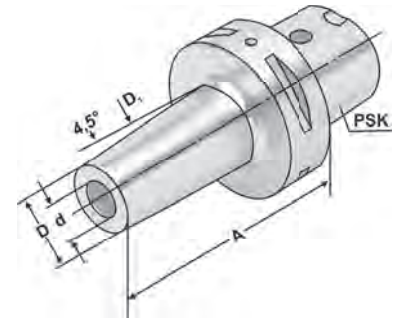

ISO 26623

 $\nabla \leq 0,003$ G2,5
25.000 min⁻¹

6

Bestell-Nr. Order no. Référence	PSK	d	A	D	D ₁	l ₁	l ₂
C3.70.06	C3	6	60	21	27	36	10
C3.70.08	C3	8	107	21	27	36	10
C3.70.10	C3	10	95	24	32	41	10
C3.70.12	C3	12	84	24	32	47	10
C4.70.06	C4	6	75	21	27	36	10
C4.70.08	C4	8	75	21	27	36	10
C4.70.10	C4	10	75	24	32	41	10
C4.70.12	C4	12	75	24	32	47	10
C4.70.14	C4	14	80	27	34	47	10
C4.70.16	C4	16	80	27	34	50	10
C4.70.18	C4	18	80	33	42	50	10
C4.70.20	C4	20	85	33	42	52	10
C5.70.06	C5	6	75	21	27	36	10
C5.70.08	C5	8	75	21	27	36	10
C5.70.10	C5	10	75	24	32	41	10
C5.70.12	C5	12	75	24	32	47	10
C5.70.14	C5	14	80	27	34	47	10
C5.70.16	C5	16	80	27	34	50	10
C5.70.18	C5	18	80	33	42	50	10
C5.70.20	C5	20	85	33	42	52	10
C5.70.25	C5	25	90	44	53	58	10

Hinweis: Aufnahmen für Induktiv-, Kontakt- und Heißluftschumpfergeräte geeignet.
Schafttoleranz bei $\varnothing 6 - \varnothing 32$ mm = h₆

Note: Toolholders suitable for induction-, contact- and hot air shrink units.
 $\varnothing 6 - \varnothing 32$ with h₆-tolerance

Observation: Porte-outils convenables pour machines à fretter par induction-,
par contact-, ou par air chaud. $\varnothing 6 - \varnothing 32$ avec h₆-tolerance

l₁ = max. Einstecktiefe l₂ = max. Verstellweg
l₁ = max. clamping depth l₂ = max. length adjustment range
l₁ = max. profondeur d'insertion l₂ = max. course de réglage



Shrink chucks 4,5°
Mandrins de frettage 4,5°



Verwendung:
Zur Aufnahme von Werkzeugen mit Zylinderschaft.

Application:
For mounting straight-shank tools.

Application:
Pour le serrage d'outils avec queue cylindrique.

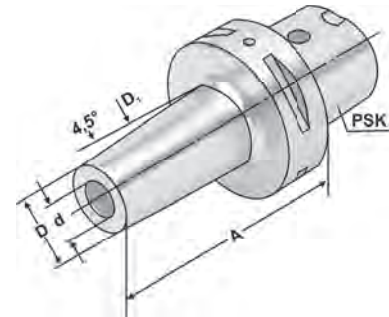

ISO 26623

$\nabla \leq 0,003$

G2,5
25.000 min⁻¹

Bestell-Nr. Order no. Référence	PSK	d	A	D	D ₁	l ₁	l ₂
C6.70.06	C6	6	80	21	27	36	10
C6.70.08	C6	8	80	21	27	36	10
C6.70.10	C6	10	80	24	32	41	10
C6.70.12	C6	12	80	24	32	47	10
C6.70.14	C6	14	85	27	34	47	10
C6.70.16	C6	16	85	27	34	50	10
C6.70.18	C6	18	85	33	42	50	10
C6.70.20	C6	20	85	33	42	52	10
C6.70.25	C6	25	90	44	53	58	10
C6.70.32	C6	32	95	44	53	62	10

Hinweis: Aufnahmen für Induktiv-, Kontakt- und Heißluftschumpfergeräte geeignet.
Schafttoleranz bei Ø 6 - Ø 32 mm = h₆

Note: Toolholders suitable for induction-, contact- and hot air shrink units.
Ø 6 - Ø 32 with h₆-tolerance

Observation: Porte-outils convenables pour machines à fretter par induction-, par contact-, ou par air chaud. Ø 6 - Ø 32 avec h₆-tolerance

l₁ = max. Einstecktiefe l₂ = max. Verstellweg
l₁ = max. clamping depth l₂ = max. length adjustment range
l₁ = max. profondeur d'insertion l₂ = max. course de réglage

Gewuchtete Ausführung

Balanced type
Type équilibré



Bestell-Nr. Order no. Référence	Abmessung Size Dimension
Wuchten auf G 2,5 von vorgewuchteten Kemmler-Werkzeugen Balancing at G 2.5 of pre-balanced Kemmler-tools Équilibrage sur G 2,5 d'outils Kemmler pré-équilibrés	
W25	Ohne Wuchtprotokoll Without balancing report Sans protocole d'équilibrage
W25.2	Mit Wuchtprotokoll With balancing report Avec protocole d'équilibrage
Wuchten von nicht vorgewuchteten Werkzeugen Balancing of unbalanced tools Équilibrage d'outils non-équilibrés	
W25.1	Ohne Wuchtprotokoll Without balancing report Sans protocole d'équilibrage





Universal ball bearing tightening fixture
Bloc de montage universel avec palier à billes



Verwendung:
Montagevorrichtung zur vertikalen und horizontalen Aufnahme von Werkzeugen mit Steilkegelschaft.

Application:
Assembly device for vertical and horizontal mounting of tools with steep taper shank.

Application:
Dispositif de montage pour le montage vertical et horizontal de porte-outils conique.

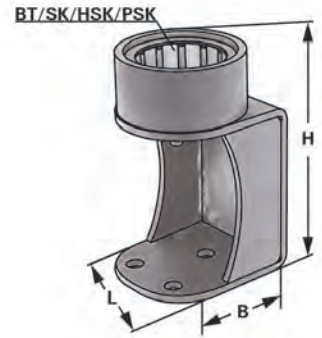

Bestell-Nr. Order no. Référence	Abmessung Size Dimension	L	B	H
706.63	C6 - HSK 63 - SK 40 - BT 40 - CAT 40	200	150	250



Hinweis: Max. Anzugsmoment 150 Nm
Note: Max. tightening torque 150 Nm
Observation: Couple de serrage maxi. 150 Nm

Coolant tubes
Canules de lubrification



Verwendung:
Zur zentralen Übergabe von Kühlmittel bei C6-Werkzeugaufnahmen.

Application:
For the coolant supply through the centre of C6 toolholders.

Application:
Pour l'arrosage centrale de porte-outils C6

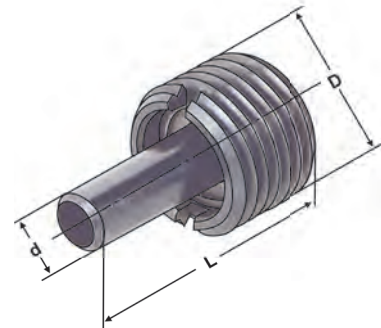

ISO 26623

Bestell-Nr. Order no. Référence	PSK	D	d	L
C6.700	C6	M20 × 1	8	33

- Hinweis:** Axial abgedichtet mit zwei O-Ringen.
Die Kühlmittelübergabeeinheit ist nach dem Einbau, gemäß DIN, minimal beweglich ($\pm 1^\circ$).
- Note:** *Axial sealed with two O-rings.*
After mounting, the coolant tube can be moved only to a minimum degree according to DIN ($\pm 1^\circ$).
- Observation:** Etanche axiale avec deux joints toriques.
Après le montage, la canule de lubrification peut être déplacée légèrement suivant DIN ($\pm 1^\circ$).

WERKZEUGAUFNAHMEN
DIN 69880 (VDI 3425)
DIN ISO 10889

TOOLHOLDERS
DIN 69880 (VDI 3425)
DIN ISO 10889

PORTE-OUTILS
DIN 69880 (VDI 3425)
DIN ISO 10889

DIN 69880

HAAS BMT 65

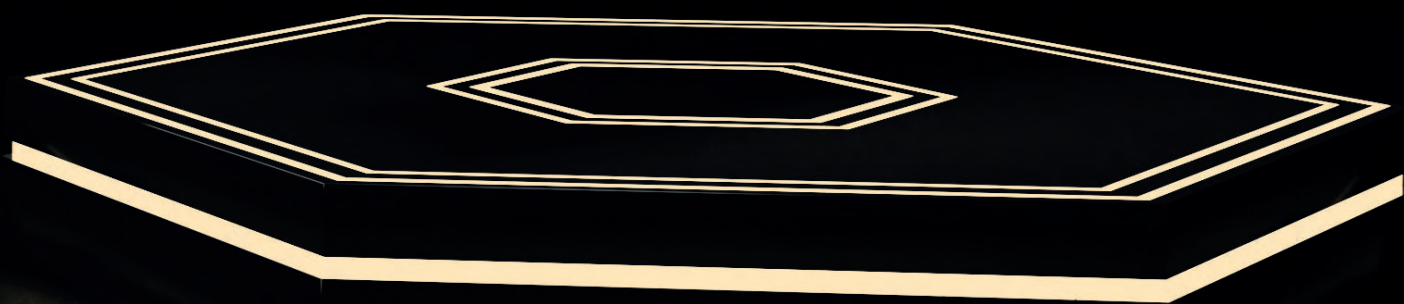
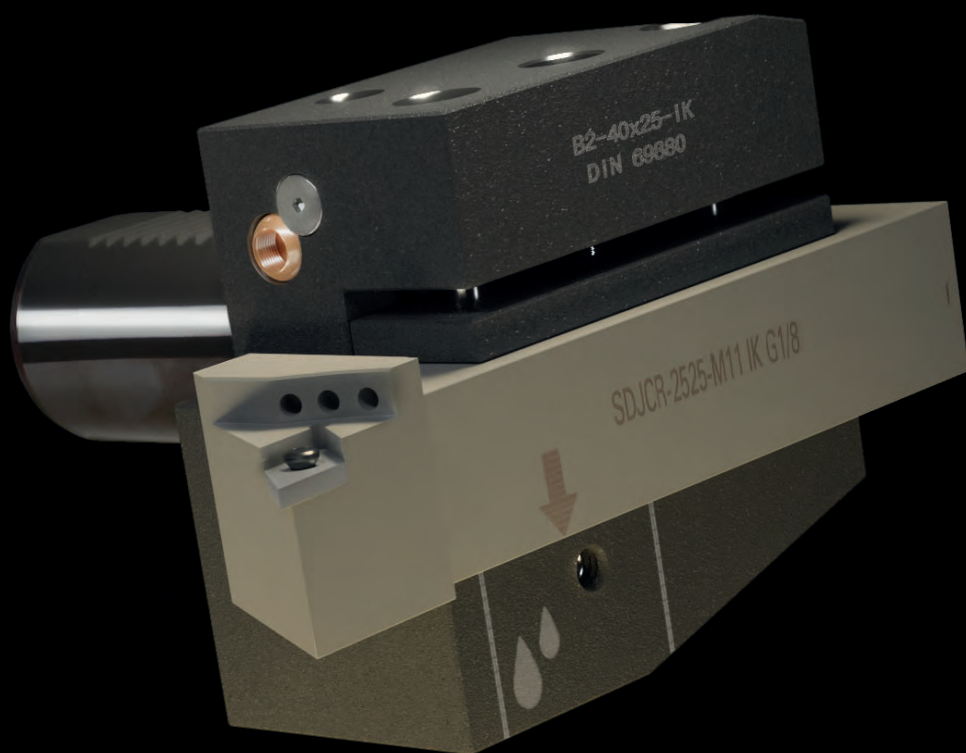

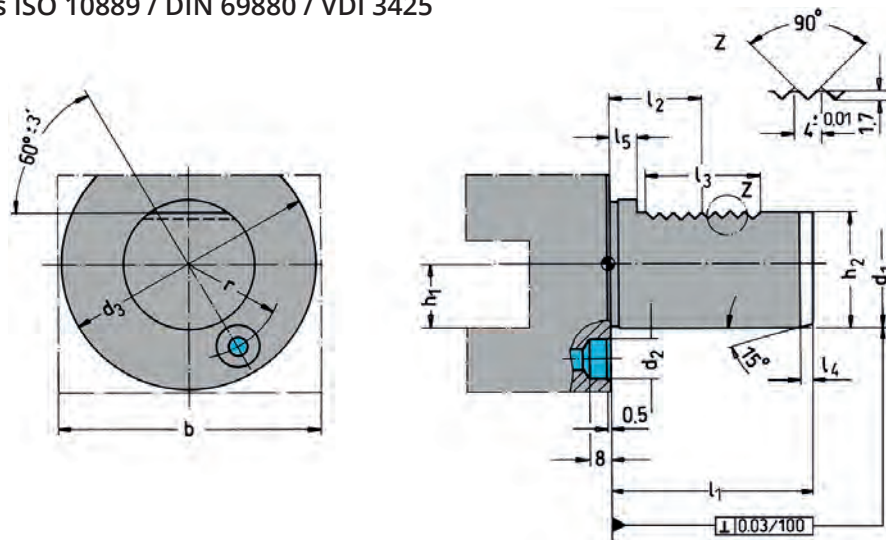

d ₁ h ₆	b	h ₁ max.	d ₂	d ₃	h ₂ ± 0,1	r ± 0,02	l ₁ max.	l ₂ ± 0,05	l ₃ max.	l ₄ max.	l ₅
16	42	12	8	40	15,0	14,5	32	12,7	16	2	3,5
20	52	16	10	50	18,0	18,0	40	21,7	24	2	7,0
25	60	16	10	58	23,5	21,0	48	21,7	24	2	7,0
30	70	20	14	68	27,0	25,0	55	29,7	40	2	7,0
40	85	25	14	83	36,0	32,0	63	29,7	40	3	7,0
50	100	32	16	98	45,0	37,0	78	35,7	48	3	8,0

7

Werkstoff: Legierter Einsatzstahl mit einer Zugfestigkeit im Kern von min. 800 N / mm².
 Einsatzgehärtet HRC 60 ± 2 (HV 700 ± 50), Härtetiefe 0,8 mm ± 0,2 mm,
 brüniert und präzisionsgeschliffen.

Ausführung: Mit innerer Kühlmittelzufuhr bzw. mit Gewindeanschluss für externe Kühlmittelzufuhr.

Material: Alloyed case-hardened steel, tensile core strength of min. 800 N / mm².
 Case hardened HRC 60 ± 2 (HV 700 ± 50), hardening depth 0.8 mm ± 0.2 mm,
 black-finished and precisely grinded.

Version: With internal coolant resp. with threaded connection for external coolant.

Matière: Acier de cémentation allié. Résistance à la traction dans le noyau de min 800 N / mm².
 Cémentation à HRC 60 ± 2 (HV 700 ± 50), profondeur de cémentation 0,8 mm ± 0,2 mm,
 bruni et rectifié précisément.

Version: Avec arrosage interne respectivement avec raccord fileté pour arrosage externe.

Werkzeugzuordnung für Scheibenrevolver

Tool assignment for disc turrets

Assignation des outils pour machines avec tourelle à disque

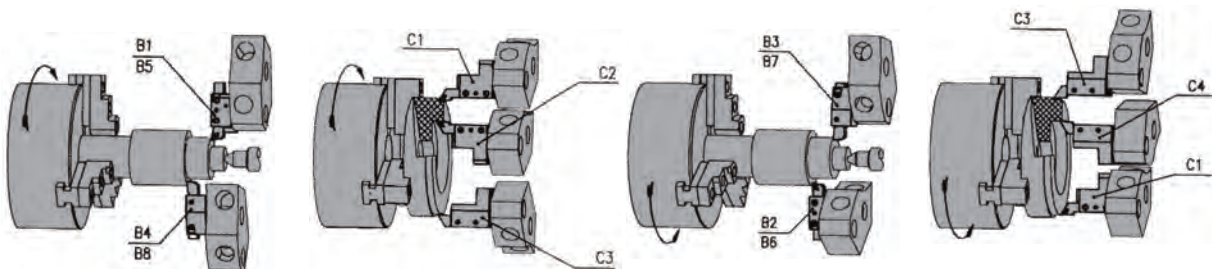

Einsatz von Werkzeughaltern bei linker Spindeldrehrichtung
 Application of tool holders with anti-clockwise spindle rotation
 Utilisation d'attachements avec la broche en sens anti-horaire

Einsatz von Werkzeughaltern bei rechter Spindeldrehrichtung
 Application of tool holders with clockwise spindle rotation
 Utilisation d'attachements avec la broche en sens horaire



Static and power-driven tools for CNC lathes and machining centers
 Porte-outils statiques ou rotatifs pour tours CNC

7.05 B1	7.07 B2	7.09 B3	7.11 B4
7.13 B5	7.14 B6	7.15 B7	7.16 B8
7.17 C1	7.19 C2	7.21 C3	7.23 C4
7.25 7.26 D1 D2	7.27 7.28 AR AL	7.29 E3	7.30 E4
7.31 E1	7.32 E2	7.33 E2	7.35 E2
7.37 F1	7.38 Z2	7.39 Z2	7.41 Z2
7.42 A1 A2	7.43 A1 A2	7.45 7.46 A1 A2	7.47 A1 A2
7.48 HAAS BMT 65	7.52 HAAS BMT 65	7.54 HAAS BMT 65	7.56 HAAS BMT 65





Verwendung:
Vorwiegend für Außenbearbeitung.
Zum Plan Einstechen.

Application:
Mainly for external machining.
For face machining.

Application:
Principalement pour usinage extérieur.
Pour carottage.

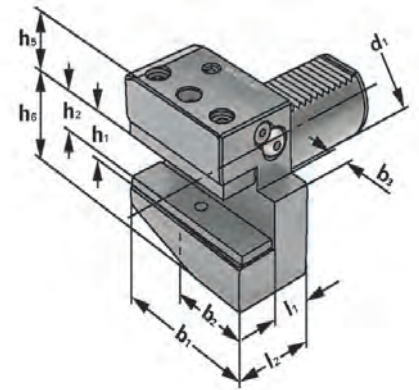

ISO 10889
DIN 69880

B1

Bestell-Nr. Order no. Référence	Abmessung Size Dimension	d ₁	h ₁	h ₂	l ₂	l ₁	b ₁	b ₂	b ₃	h ₅	h ₆
169.31.12	B1 - 16 × 12 × 24	16	12	-	24	13	42	23	5	20	22
209.31.16	B1 - 20 × 16 × 30	20	16	12	30	16	55	30	7	25	30
259.31.16	B1 - 25 × 16 × 30	25	16	12	30	16	55	30	7	25	30
309.31.20	B1 - 30 × 20 × 40	30	20,5	16	40	22	70	35	10	28	38
409.31.25	B1 - 40 × 25 × 44	40	25	20	44	22	85	42,5	12,5	32,5	48
509.31.32	B1 - 50 × 32 × 55	50	33	26	55	30	100	50	16	35	60

Ausführung: Mit einstellbarer Kugelspritzdüse und Unterlegplatte
Version: With adjustable spray nozzle and shim
Version: Avec gicleur ajustable et semelle





Radial toolholders form B1 right, short - for tools with internal coolant
 Porte-outils radials forme B1 droite, pour - outils avec arrosage interne



Verwendung:
 Vorwiegend für Außenbearbeitung.
 Zum Plan Einstechen.

Application:
 Mainly for external machining.
 For face machining.

Application:
 Principalement pour usinage extérieur.
 Pour carottage.

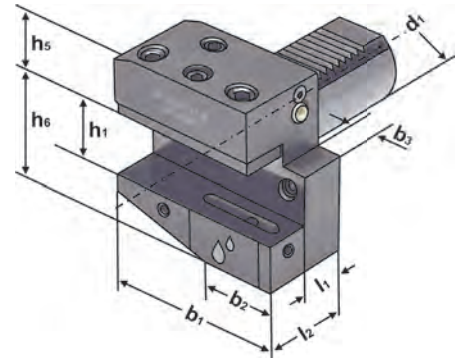

ISO 10889
 DIN 69880

B1



Bestell-Nr. Order no. Référence	Abmessung Size Dimension	d ₁	h ₁	l ₂	l ₁	b ₁	b ₂	b ₃	h ₅	h ₆
309.31.20.IK	B1 - 30 × 20 × 40	30	20	40	22	70	35	10	28	38
409.31.25.IK	B1 - 40 × 25 × 44	40	25	44	22	85	42,5	12,5	32,5	48
509.31.32.IK	B1 - 50 × 32 × 55	50	32	55	30	100	50	16	35	60

Ausführung: Mit einstellbarer Kugelspritzdüse
Version: With adjustable spray nozzle
Version: Avec gicleur ajustable

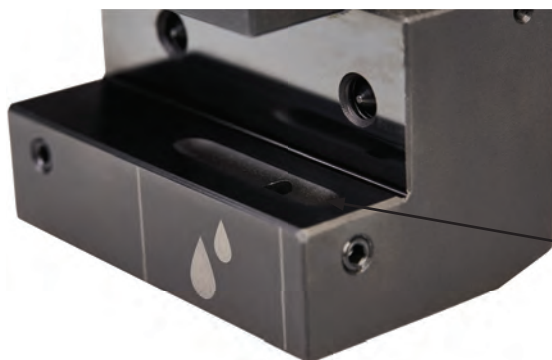

Übergabe für Kühlmittel
 Coolant supply
 Jonction d'arrosage

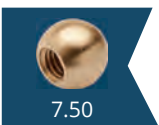



Verwendung:
Vorwiegend für Außenbearbeitung.
Zum Plan Einstechen.

Application:
Mainly for external machining.
For face machining.

Application:
Principalement pour usinage extérieur.
Pour carottage.

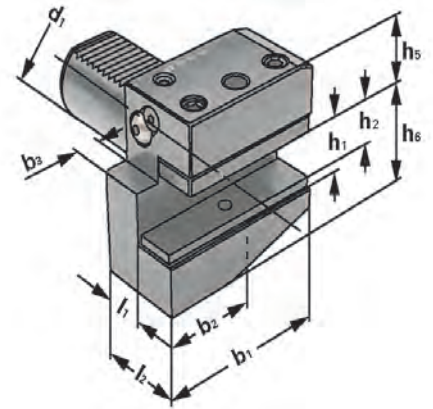

ISO 10889
DIN 69880

B2

Bestell-Nr. Order no. Référence	Abmessung Size Dimension	d ₁	h ₁	h ₂	l ₂	l ₁	b ₁	b ₂	b ₃	h ₅	h ₆
169.32.12	B2 – 16 × 12 × 24	16	12	-	24	13	42	23	5	20	22
209.32.16	B2 – 20 × 16 × 30	20	16	12	30	16	55	30	7	25	30
259.32.16	B2 – 25 × 16 × 30	25	16	12	30	16	55	30	7	25	30
309.32.20	B2 – 30 × 20 × 40	30	24,5	20,5	40	22	70	35	10	23,5	42,5
409.32.25	B2 – 40 × 25 × 44	40	28	23	44	22	85	42,5	12,5	23,5	42,5
509.32.32	B2 – 50 × 32 × 55	50	33	26	55	30	100	50	16	35	60

Ausführung: Mit einstellbarer Kugelspritzdüse und Unterlegplatte
Version: With adjustable spray nozzle and shim
Version: Avec gicleur ajustable et semelle



7.48



7.50



Radial toolholders form B2 left, short - for tools with internal coolant
 Porte-outils radials forme B2 gauche, court - pour outils avec arrosage interne



Verwendung:
 Vorwiegend für Außenbearbeitung.
 Zum Plan Einstechen.

Application:
 Mainly for external machining.
 For face machining.

Application:
 Principalement pour usinage extérieur.
 Pour carottage.

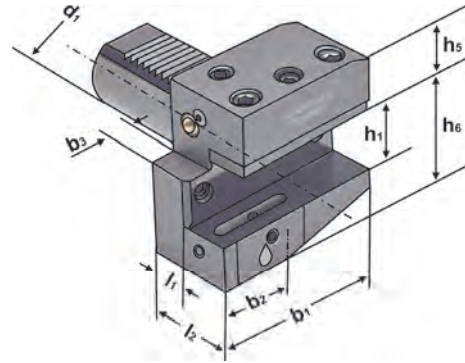

ISO 10889
 DIN 69880

B2

IC

Bestell-Nr. Order no. Référence	Abmessung Size Dimension	d ₁	h ₁	l ₂	l ₁	b ₁	b ₂	b ₃	h ₅	h ₆
309.32.20.IK	B2 - 30 × 20 × 40	30	20	40	22	70	35	10	28	38
409.32.25.IK	B2 - 40 × 25 × 44	40	25	44	22	85	42,5	12,5	32,5	48
509.32.32.IK	B2 - 50 × 32 × 55	50	32	55	30	100	50	16	35	60

Ausführung: Mit einstellbarer Kugelspritzdüse
Version: With adjustable spray nozzle
Version: Avec gicleur ajustable

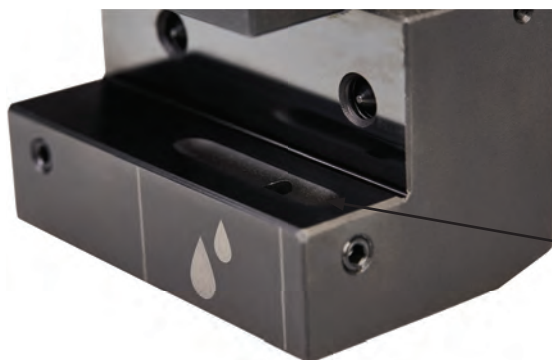

Übergabe für Kühlmittel
 Coolant supply
 Jonction d'arrosage





Verwendung:
Vorwiegend für Außenbearbeitung.
Zum Plan Einstechen.

Application:
Mainly for external machining.
For face machining.

Application:
Principalement pour usinage extérieur.
Pour carottage.

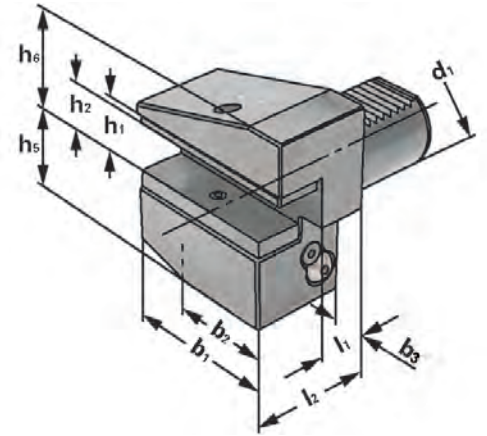

ISO 10889
DIN 69880

B3

Bestell-Nr. Order no. Référence	Abmessung Size Dimension	d ₁	h ₁	h ₂	l ₂	l ₁	b ₁	b ₂	b ₃	h ₅	h ₆
169.33.12	B3 - 16 × 12 × 24	16	12	-	24	13	42	23	5	20	22
209.33.16	B3 - 20 × 16 × 30	20	16	12	30	16	55	30	7	25	30
259.33.16	B3 - 25 × 16 × 30	25	16	12	30	16	55	30	7	25	30
309.33.20	B3 - 30 × 20 × 40	30	25	20,5	40	22	70	35	10	30	43
409.33.25	B3 - 40 × 25 × 44	40	29	23	44	22	85	42,5	12,5	39,5	51
509.33.32	B3 - 50 × 32 × 55	50	34	26	55	30	100	50	16	49	61

Ausführung: Mit einstellbarer Kugelspritzdüse und Unterlegplatte
Version: With adjustable spray nozzle and shim
Version: Avec gicleur ajustable et semelle



7.48



7.50



Radial toolholders form B3 overhead right, short - for tools with internal coolant
 Porte-outils radials forme B3 inversés droite, court - pour outils avec arrosage interne



Verwendung:
 Vorwiegend für Außenbearbeitung.
 Zum Plan Einstechen.

Application:
 Mainly for external machining.
 For face machining.

Application:
 Principalement pour usinage extérieur.
 Pour carottage.

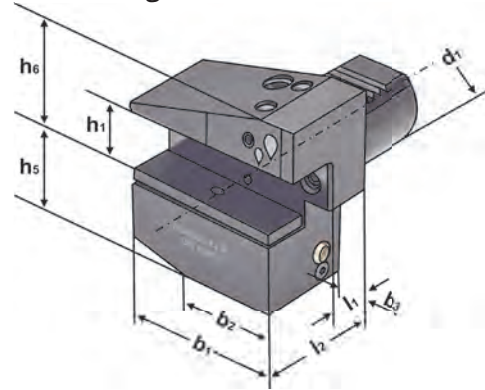

ISO 10889
 DIN 69880

B3

IC

Bestell-Nr. Order no. Référence	Abmessung Size Dimension	d1	h1	l2	l1	b1	b2	b3	h5	h6
309.33.20.IK	B3 - 30 × 20 × 40	30	20	40	22	70	35	10	35	38
409.33.25.IK	B3 - 40 × 25 × 44	40	25	44	22	85	42,5	12,5	42,5	48
509.33.32.IK	B3 - 50 × 32 × 55	50	32	55	30	100	50	16	50	60

Ausführung: Mit einstellbarer Kugelspritzdüse
Version: With adjustable spray nozzle
Version: Avec gicleur ajustable

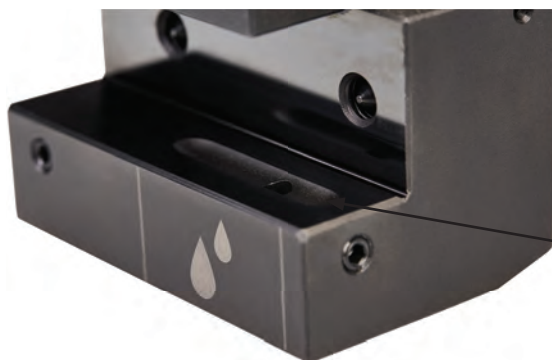

Übergabe für Kühlmittel
 Coolant supply
 Jonction d'arrosage

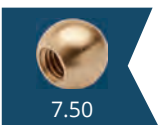



Verwendung:
Vorwiegend für Außenbearbeitung.
Zum Plan Einstechen.

Application:
Mainly for external machining.
For face machining.

Application:
Principalement pour usinage extérieur.
Pour carottage.

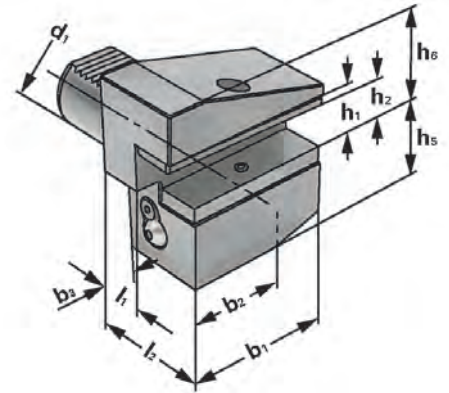

ISO 10889
DIN 69880

B4

Bestell-Nr. Order no. Référence	Abmessung Size Dimension	d ₁	h ₁	h ₂	l ₂	l ₁	b ₁	b ₂	b ₃	h ₅	h ₆
169.34.12	B4 – 16 × 12 × 24	16	12	-	24	13	42	23	5	20	22
209.34.16	B4 – 20 × 16 × 30	20	16	12	30	16	55	30	7	35	30
259.34.16	B4 – 25 × 16 × 30	25	16	12	30	16	55	30	7	35	30
309.34.20	B4 – 30 × 20 × 40	30	25	20,5	40	22	70	35	10	30	42,5
409.34.25	B4 – 40 × 25 × 44	40	29	23	44	22	85	42,5	12,5	39,5	51
509.34.32	B4 – 50 × 32 × 55	50	34	26	55	30	100	50	16	49	61

7

Ausführung: Mit einstellbarer Kugelspritzdüse und Unterlegplatte
Version: With adjustable spray nozzle and shim
Version: Avec gicleur ajustable et semelle



7.48



7.50



Radial toolholders form B4 overhead left, short - for tools with internal coolant

Porte-outils radials forme B4 inversés gauche, court - pour outils avec arrosage interne



Verwendung:
Vorwiegend für Außenbearbeitung.
Zum Plan Einstechen.

Application:
Mainly for external machining.
For face machining.

Application:
Principalement pour usinage extérieur.
Pour carottage.

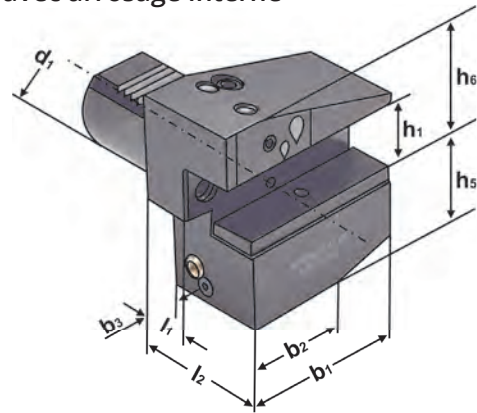

ISO 10889
DIN 69880

B4

IC

Bestell-Nr. Order no. Référence	Abmessung Size Dimension	d1	h1	l2	l1	b1	b2	b3	h5	h6
309.34.20.IK	B4 - 30 × 20 × 40	30	20	40	22	70	35	10	35	38
409.34.25.IK	B4 - 40 × 25 × 44	40	25	44	22	85	42,5	12,5	42,5	48
509.34.32.IK	B4 - 50 × 32 × 55	50	32	55	30	100	50	16	50	60

Ausführung: Mit einstellbarer Kugelspritzdüse
Version: With adjustable spray nozzle
Version: Avec gicleur ajustable

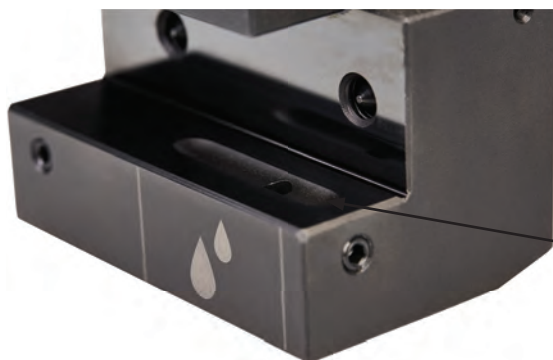

Übergabe für Kühlmittel
Coolant supply
Jonction d'arrosage

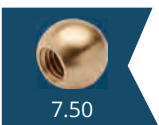



Verwendung:
Vorwiegend für Außenbearbeitung.
Zum Plan Einstechen.

Application:
Mainly for external machining.
For face machining.

Application:
Principalement pour usinage extérieur.
Pour carottage.

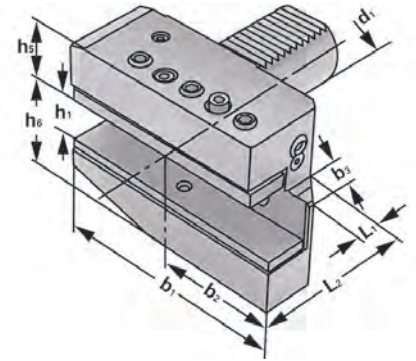

ISO 10889
DIN 69880

B5

Bestell-Nr. Order no. Référence	Abmessung Size Dimension	d ₁	b ₁	b ₂	b ₃	L ₁	L ₂	h ₁	h ₅	h ₆
169.35.12	B5 - 16 × 12 × 24	16	58	39	5	13	24	12	22	20
209.35.16	B5 - 20 × 16 × 30	20	75	50	7	16	30	16	25	30
259.35.16	B5 - 25 × 16 × 30	25	75	50	7	16	30	16	25	30
309.35.20	B5 - 30 × 20 × 40	30	100	65	10	22	40	20	28	38
409.35.25	B5 - 40 × 25 × 44	40	118	75,5	12,5	22	44	25	32,5	48
509.35.32	B5 - 50 × 32 × 55	50	130	85	16	30	55	32	35	60

Ausführung: Mit einstellbarer Kugelspritzdüse und Unterlegplatte
Version: With adjustable spray nozzle and shim
Version: Avec gicleur ajustable et semelle

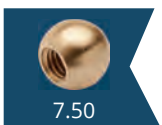

7.50



Radial toolholders form B6 left, long
 Porte-outils radials forme B6 gauche, long

DIN 69880 (VDI 3425)



Verwendung:
 Vorwiegend für Außenbearbeitung.
 Zum Plan Einstechen.

Application:
 Mainly for external machining.
 For face machining.

Application:
 Principalement pour usinage extérieur.
 Pour carottage.

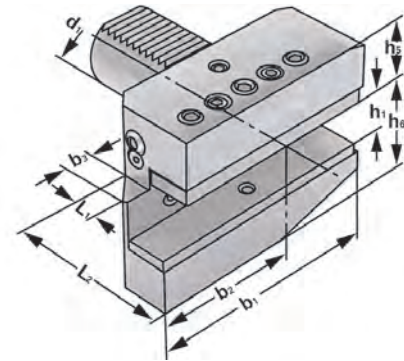

ISO 10889
 DIN 69880

B6

Bestell-Nr. Order no. Référence	Abmessung Size Dimension	d ₁	b ₁	b ₂	b ₃	L ₁	L ₂	h ₁	h ₅	h ₆
169.36.12	B6 - 16 × 12 × 24	16	58	39	5	13	24	12	22	20
209.36.16	B6 - 20 × 16 × 30	20	75	50	7	16	30	16	25	30
259.35.16	B6 - 25 × 16 × 30	25	75	50	7	16	30	16	25	30
309.36.20	B6 - 30 × 20 × 40	30	100	65	10	22	40	20	28	38
409.36.25	B6 - 40 × 25 × 44	40	118	75,5	12,5	22	44	25	32,5	48
509.36.32	B6 - 50 × 32 × 55	50	130	80	16	30	55	32	35	60

Ausführung: Mit einstellbarer Kugelspritzdüse und Unterlegplatte
Version: With adjustable spray nozzle and shim
Version: Avec gicleur ajustable et semelle

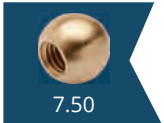



Verwendung:
Vorwiegend für Außenbearbeitung.
Zum Plan Einstechen.

Application:
Mainly for external machining.
For face machining.

Application:
Principalement pour usinage extérieur.
Pour carottage.

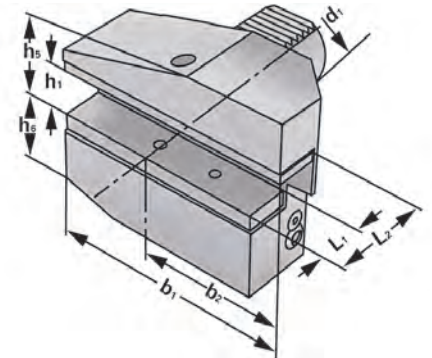

ISO 10889
DIN 69880

B7

Bestell-Nr. Order no. Référence	Abmessung Size Dimension	d ₁	b ₁	b ₂	b ₃	L ₁	L ₂	h ₁	h ₅	h ₆
169.37.12	B7 - 16 × 12 × 24	16	58	39	5	13	24	12	20	22
209.37.16	B7 - 20 × 16 × 30	20	75	50	7	16	30	16	30	25
259.37.16	B7 - 25 × 16 × 30	25	75	50	7	16	30	16	30	25
309.37.20	B7 - 30 × 20 × 40	30	100	65	10	22	40	20	42	30
409.37.25	B7 - 40 × 25 × 44	40	118	75,5	12,5	22	44	25	48	42,5
509.37.32	B7 - 50 × 32 × 55	50	130	80	16	30	55	32	60	50

Ausführung: Mit einstellbarer Kugelspritzdüse und Unterlegplatte
Version: With adjustable spray nozzle and shim
Version: Avec gicleur ajustable et semelle

7

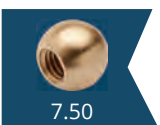

7.50



Radial toolholders form B8 overhead left, long
 Porte-outils radials forme B8 inversé gauche, long

DIN 69880 (VDI 3425)



Verwendung:
 Vorwiegend für Außenbearbeitung.
 Zum Plan Einstechen.

Application:
 Mainly for external machining.
 For face machining.

Application:
 Principalement pour usinage extérieur.
 Pour carottage.

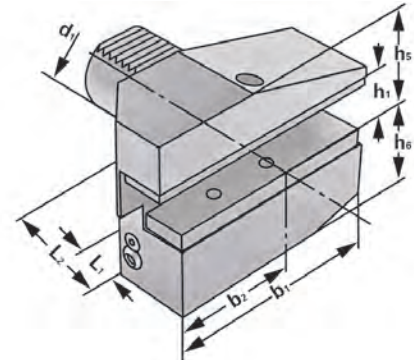

ISO 10889
 DIN 69880

B8

Bestell-Nr. Order no. Référence	Abmessung Size Dimension	d ₁	b ₁	b ₂	b ₃	L ₁	L ₂	h ₁	h ₅	h ₆
169.38.12	B8 - 16 × 12 × 24	16	58	39	5	13	24	12	20	22
209.38.16	B8 - 20 × 16 × 30	20	75	50	7	16	30	16	30	25
259.38.16	B8 - 25 × 16 × 30	25	75	50	7	16	30	16	30	25
309.38.20	B8 - 30 × 20 × 40	30	100	65	10	22	40	20	38	35
409.38.25	B8 - 40 × 25 × 44	40	118	75,5	12,5	22	44	25	48	42,5
509.38.32	B8 - 50 × 32 × 55	50	130	80	16	30	55	32	60	50

Ausführung: Mit einstellbarer Kugelspritzdüse und Unterlegplatte
Version: With adjustable spray nozzle and shim
Version: Avec gicleur ajustable et semelle

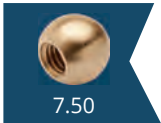



Verwendung:
Vorwiegend für Außenbearbeitung.
Zum Plan Einstechen.

Application:
Mainly for external machining.
For face machining.

Application:
Principalement pour usinage extérieur.
Pour carottage.

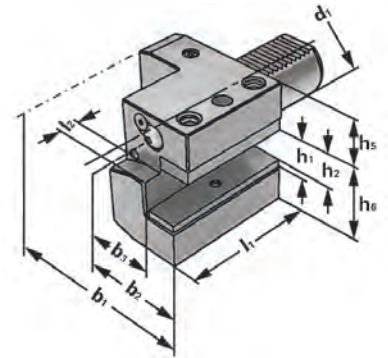

ISO 10889
DIN 69880

C1

Bestell-Nr. Order no. Référence	Abmessung Size Dimension	d ₁	h ₁	h ₂	b ₁	b ₂	b ₃	l ₁	l ₂	h ₅	h ₆
169.41.12	C1 – 16 × 12	16	12	10	43	24	13	44	5	20	22
209.41.16	C1 – 20 × 16	20	16	12	52	27	13	50	7	25	30
259.41.16	C1 – 25 × 16	25	16	12	58	33	19	55	7	25	30
309.41.20	C1 – 30 × 20	30	20	16	70	35	17	70	10	28	38
409.41.25	C1 – 40 × 25	40	25	20	85	42,5	21	85	12,5	32,5	48
509.41.32	C1 – 50 × 32	50	32	25	100	50	26	100	16	35	60

7

Ausführung: Mit einstellbarer Kugelspritzdüse und Unterlegplatte
Version: With adjustable spray nozzle and shim
Version: Avec gicleur ajustable et semelle



7.48



7.50



Axial toolholders form C1 right - for tools with internal coolant
 Porte-outils axials forme C1 droite - pour outils avec arrosage interne



Verwendung:
 Vorwiegend für Außenbearbeitung.
 Zum Plan Einstechen.

Application:
 Mainly for external machining.
 For face machining.

Application:
 Principalement pour usinage extérieur.
 Pour carottage.

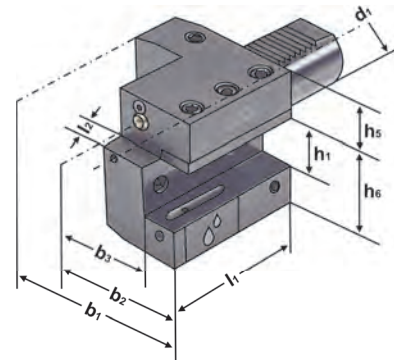

ISO 10889
 DIN 69880

C1

IC

Bestell-Nr. Order no. Référence	Abmessung Size Dimension	d1	h1	b1	b2	b3	l1	l2	h5	h6
309.41.20.IK	C1 - 30 × 20	30	20	76	49	31	70	10	24	42
409.41.25.IK	C1 - 40 × 25	40	25	90	55	33	85	12,5	32,5	48
509.41.32.IK	C1 - 50 × 32	50	32	105	62	38	100	16	35	60

Ausführung: Mit einstellbarer Kugelspritzdüse
Version: With adjustable spray nozzle
Version: Avec gicleur ajustable

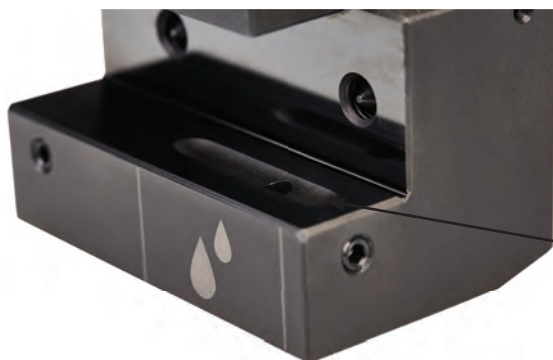

Übergabe für Kühlmittel
 Coolant supply
 Jonction d'arrosage





Verwendung:
Vorwiegend für Außenbearbeitung.
Zum Plan Einstechen.

Application:
Mainly for external machining.
For face machining.

Application:
Principalement pour usinage extérieur.
Pour carottage.

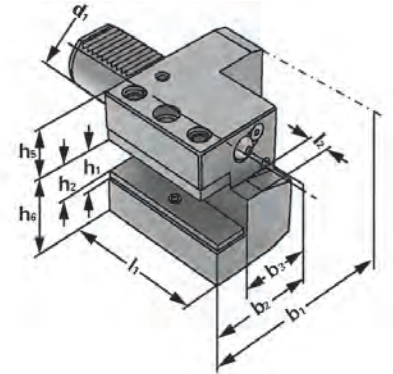

ISO 10889
DIN 69880

C2

Bestell-Nr. Order no. Référence	Abmessung Size Dimension	d ₁	h ₁	h ₂	b ₁	b ₂	b ₃	l ₁	l ₂	h ₅	h ₆
169.42.12	C2 – 16 × 12	16	12	–	43	24	13	44	5	20	22
209.42.16	C2 – 20 × 16	20	16	12	65	40	26	50	7	25	30
259.42.16	C2 – 25 × 16	25	16	12	58	33	26	55	7	20	30
309.42.20	C2 – 30 × 20	30	20	16	76	41	23	70	10	28	38
409.42.25	C2 – 40 × 25	40	25	20	90	47,5	25,5	85	12,5	32,5	48
509.42.32	C2 – 50 × 32	50	32	25	105	55	30,5	100	16	35	60



Ausführung: Mit einstellbarer Kugelspritzdüse und Unterlegplatte
Version: With adjustable spray nozzle and shim
Version: Avec gicleur ajustable et semelle





für Werkzeuge mit Innenkühlung

DIN 69880 (VDI 3425)

Axial toolholders form C2 left - for tools with internal coolant
 Porte-outils axials forme C2 gauche - pour outils avec arrosage interne



Verwendung:
 Vorwiegend für Außenbearbeitung.
 Zum Plan Einstechen.

Application:
 Mainly for external machining.
 For face machining.

Application:
 Principalement pour usinage extérieur.
 Pour carottage.

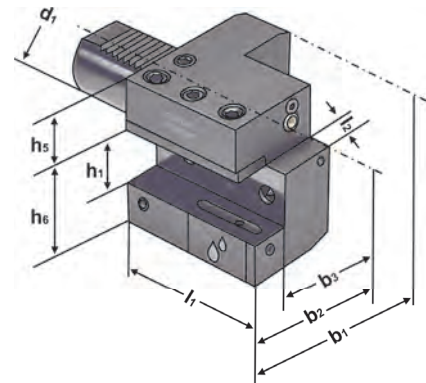

ISO 10889
 DIN 69880

C2

IC

Bestell-Nr. Order no. Référence	Abmessung Size Dimension	d1	h1	b1	b2	b3	l1	l2	h5	h6
309.42.20.IK	C2 - 30 × 20	30	20	76	49	31	70	10	24	42
409.42.25.IK	C2 - 40 × 25	40	25	90	55	33	85	12,5	32,5	48
509.42.32.IK	C2 - 50 × 32	50	32	105	62	38	100	16	35	60

Ausführung: Mit einstellbarer Kugelspritzdüse
Version: With adjustable spray nozzle
Version: Avec gicleur ajustable

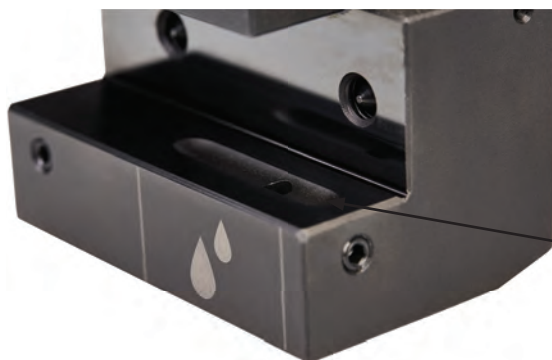

Übergabe für Kühlmittel
 Coolant supply
 Jonction d'arrosage

7.48

7.50



Verwendung:
Vorwiegend für Außenbearbeitung.
Zum Plan Einstechen.

Application:
Mainly for external machining.
For face machining.

Application:
Principalement pour usinage extérieur.
Pour carottage.

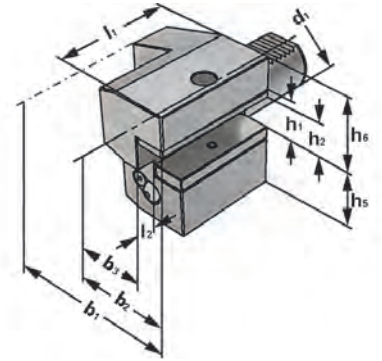

ISO 10889
DIN 69880

C3

Bestell-Nr. Order no. Référence	Abmessung Size Dimension	d ₁	h ₁	h ₂	b ₁	b ₂	b ₃	l ₁	l ₂	h ₅	h ₆
169.43.12	C3 - 16 × 12	16	12	10	43	24	13	44	5	20	22
209.43.16	C3 - 20 × 16	20	16	12	52	27	13	55	7	30	25
259.43.16	C3 - 25 × 16	25	16	12	58	33	19	55	7	30	25
309.43.20	C3 - 30 × 20	30	20	16	70	35	17	70	10	38	35
409.43.25	C3 - 40 × 25	40	25	20	85	42,5	21	85	12,5	48	42,5
509.43.32	C3 - 50 × 32	50	32	25	100	50	26	100	16	60	50

Ausführung: Mit einstellbarer Kugelspritzdüse und Unterlegplatte
Version: With adjustable spray nozzle and shim
Version: Avec gicleur ajustable et semelle

7



7.48



7.50



Axial toolholders form C3 overhead right - for tools with internal coolant
 Porte-outils axials forme C3 inversés droite - pour outils avec arrosage interne



Verwendung:
 Vorwiegend für Außenbearbeitung.
 Zum Plan Einstechen.

Application:
 Mainly for external machining.
 For face machining.

Application:
 Principalement pour usinage extérieur.
 Pour carottage.

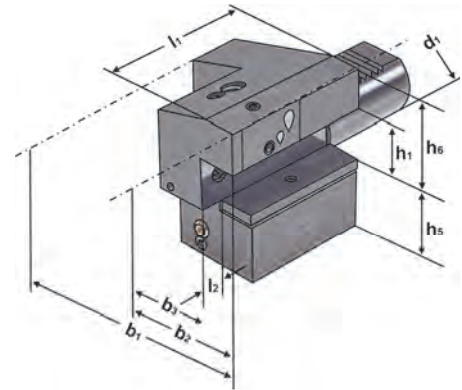

ISO 10889
 DIN 69880

C3

IC

Bestell-Nr. Order no. Référence	Abmessung Size Dimension	d1	h1	b1	b2	b3	l1	l2	h5	h6
309.43.20.IK	C3 - 30 × 20	30	20	70	35	17	70	10	38	35
409.43.25.IK	C3 - 40 × 25	40	25	85	42,5	21	85	12,5	48	42,5
509.43.32.IK	C3 - 50 × 32	50	32	100	50	26	100	16	60	50

Ausführung: Mit einstellbarer Kugelspritzdüse
Version: With adjustable spray nozzle
Version: Avec gicleur ajustable

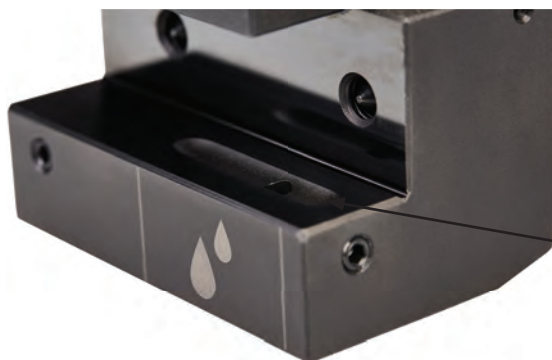

Übergabe für Kühlmittel
 Coolant supply
 Jonction d'arrosage

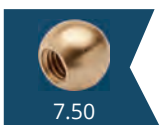



Verwendung:
Vorwiegend für Außenbearbeitung.
Zum Plan Einstechen.

Application:
Mainly for external machining.
For face machining.

Application:
Principalement pour usinage extérieur.
Pour carottage.

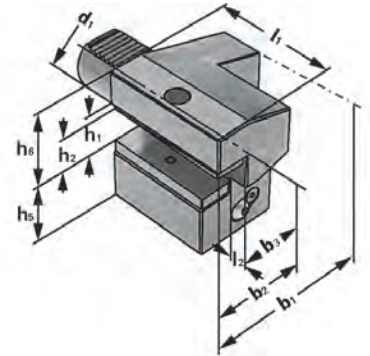

ISO 10889
DIN 69880

C4

Bestell-Nr. Order no. Référence	Abmessung Size Dimension	d ₁	h ₁	h ₂	b ₁	b ₂	b ₃	l ₁	l ₂	h ₅	h ₆
169.44.12	C4 - 16 × 12	16	12	10	43	24	13	44	5	22	20
209.44.16	C4 - 20 × 16	20	16	12	65	40	26	50	7	30	25
259.44.16	C4 - 25 × 16	25	16	12	58	33	19	55	7	30	25
309.44.20	C4 - 30 × 20	30	20	16	76	41	23	70	10	38	35
409.44.25	C4 - 40 × 25	40	25	20	90	47,5	25,5	85	12,5	48	42,5
509.44.32	C4 - 50 × 32	50	32	25	105	55	30,5	100	16	60	50

7

Ausführung: Mit einstellbarer Kugelspritzdüse und Unterlegplatte
Version: With adjustable spray nozzle and shim
Version: Avec gicleur ajustable et semelle



7.48



7.50



Axial toolholders form C4 overhead left - for tools with internal coolant
 Porte-outils axials forme C4 inversés gauche - pour outils avec arrosage interne



Verwendung:
 Vorwiegend für Außenbearbeitung.
 Zum Plan Einstechen.

Application:
 Mainly for external machining.
 For face machining.

Application:
 Principalement pour usinage extérieur.
 Pour carottage.

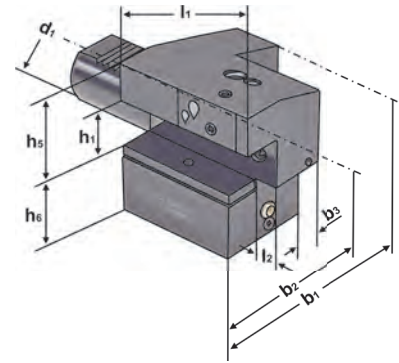

ISO 10889
 DIN 69880

C4

IC

Bestell-Nr. Order no. Référence	Abmessung Size Dimension	d1	h1	b1	b2	b3	l1	l2	h5	h6
309.44.20.IK	C4 - 30 × 20	30	20	70	35	17	70	10	38	35
409.44.25.IK	C4 - 40 × 25	40	25	85	42,5	21	85	12,5	48	42,5
509.44.32.IK	C4 - 50 × 32	50	32	100	50	26	100	16	60	50

Ausführung: Mit einstellbarer Kugelspritzdüse
Version: With adjustable spray nozzle
Version: Avec gicleur ajustable

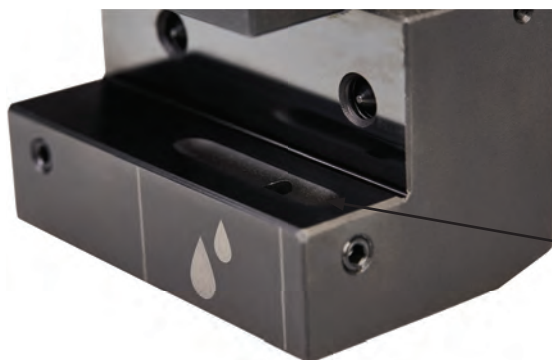

Übergabe für Kühlmittel
 Coolant supply
 Jonction d'arrosage





Verwendung:
Vorwiegend für Außenbearbeitung.
Zum Plan Einstechen.

Application:
Mainly for external machining.
For face machining.

Application:
Principalement pour usinage extérieur.
Pour carottage.

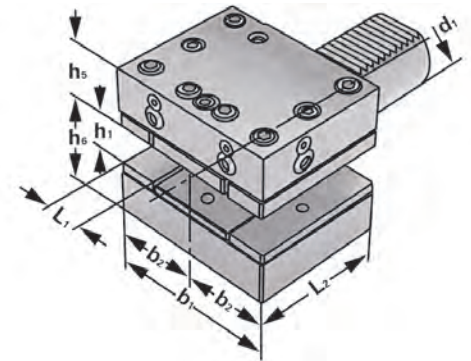

ISO 10889
DIN 69880

D1

Bestell-Nr. Order no. Référence	Abmessung Size Dimension	d ₁	b ₁	b ₂	L ₁	L ₂	h ₁	h ₅	h ₆
309.89.12	D1 - 30 × 20 × 60	30	76	41	18	60	20	28	38
409.89.16	D1 - 40 × 25 × 72	40	90	47,5	22	72	25	32,5	48
509.89.20	D1 - 50 × 32 × 85	50	105	55	24,5	85	32	35	60

Ausführung: Mit einstellbarer Kugelspritzdüse und Unterlegplatte
Version: With adjustable spray nozzle and shim
Version: Avec gicleur ajustable et semelle

7

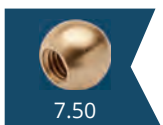



Rectangular toolholders with multiple seats, overhead form D2
 Porte-outils, multiple, inversés forme D2

DIN 69880 (VDI 3425)



Verwendung:
 Vorwiegend für Außenbearbeitung.
 Zum Plan Einstechen.

Application:
 Mainly for external machining.
 For face machining.

Application:
 Principalement pour usinage extérieur.
 Pour carottage.

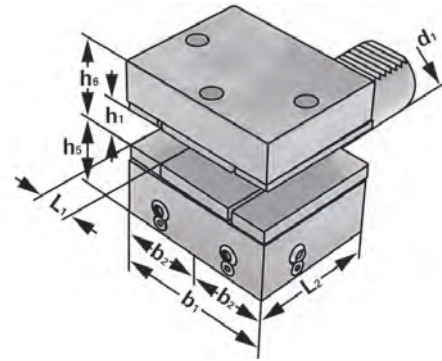

ISO 10889
 DIN 69880

D2

Bestell-Nr. Order no. Référence	Abmessung Size Dimension	d ₁	b ₁	b ₂	L ₁	L ₂	h ₁	h ₂	h ₅	h ₆
309.90.12	D2 – 30 × 20 × 60	30	76	41	18	60	20	73	35	38
409.90.16	D2 – 40 × 25 × 72	40	90	47,5	22	72	25	90,5	42,5	48
509.90.20	D2 – 50 × 32 × 85	50	105	55	24,5	85	32	110	50	60

Ausführung: Mit einstellbarer Kugelspritzdüse und Unterlegplatte
Version: With adjustable spray nozzle and shim
Version: Avec gicleur ajustable et semelle

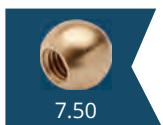



Verwendung:
Vorwiegend für Außenbearbeitung.
Zum Plan Einstechen.

Application:
Mainly for external machining.
For face machining.

Application:
Principalement pour usinage extérieur.
Pour carottage.

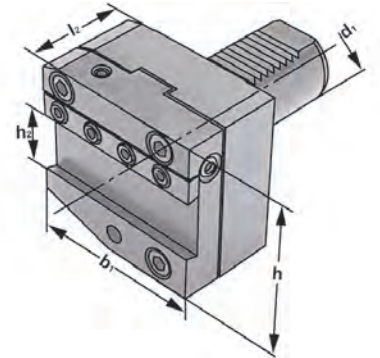

ISO 10889
DIN 69880

AR

Bestell-Nr. Order no. Référence	Abmessung Size Dimension	d ₁	b ₁	h	l ₂	h ₂
309.65.26	AR - 30 × 26	30	70	70	50	26
409.65.32	AR - 40 × 32	40	85	80	50	32
509.65.32	AR - 50 × 32	50	100	80	50	32

Ausführung: Mit einstellbarer Kugelspritzdüse
Version: With adjustable spray nozzle
Version: Avec gicleur ajustable

7

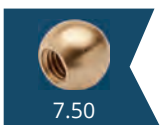

7.50



Parting-off toolholders left height adjustable
 Porte-lames de tronçonnage gauche réglage en hauteur

DIN 69880 (VDI 3425)



Verwendung:
 Vorwiegend für Außenbearbeitung.
 Zum Plan Einstechen.

Application:
 Mainly for external machining.
 For face machining.

Application:
 Principalement pour usinage extérieur.
 Pour carottage.

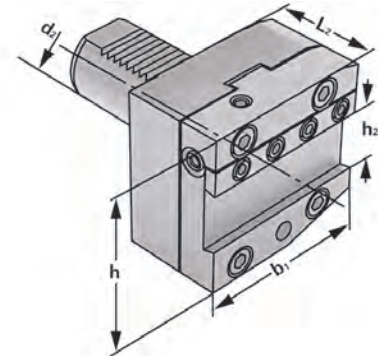

ISO 10889
 DIN 69880

AL

Bestell-Nr. Order no. Référence	Abmessung Size Dimension	d ₁	b ₁	h	l ₂	h ₂
309.66.26	AL - 30 × 26	30	70	70	50	26
409.66.32	AL - 40 × 32	40	85	80	50	32
509.66.32	AL - 50 × 32	50	100	80	50	32

Ausführung: Mit einstellbarer Kugelspritzdüse
Version: With adjustable spray nozzle
Version: Avec gicleur ajustable

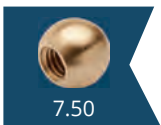



Collet chucks form E3 DIN 6391 for collets DIN 6388 (ISO 10897) OZ-system
Mandrins à pinces forme E3 DIN 6391 pour pinces DIN 6388 (ISO 10897) système OZ



Verwendung:
Zur Aufnahme von Werkzeugen mit Zylinderschaft in Spannzangen.

Application:
For mounting straight-shank tools in collets.

Application:
Pour le serrage d'outils avec queue cylindrique dans des pinces de serrage.

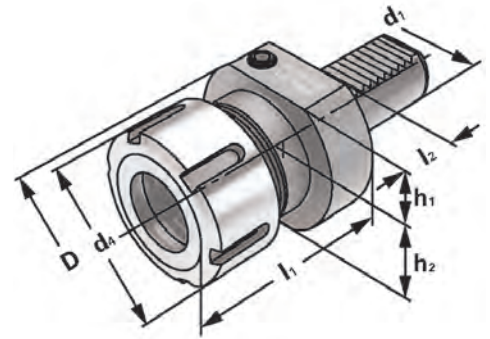

ISO 10889
DIN 69880

E3



Bestell-Nr. Order no. Référence	Abmessung Size Dimension	d ₁	Spannbereich Capacity Capacité	D	d ₄	h ₁	h ₂	l ₁	l ₂
169.01.16	E3 - 16 × 2 - 16	16	2 - 16 (OZ 16)	40	43	18	18	45,5	13
209.01.16	E3 - 20 × 2 - 16	20	2 - 16 (OZ 16)	50	43	25	23	57	18
259.01.16	E3 - 25 × 2 - 16	25	2 - 16 (OZ 16)	58	43	25	25	57	18
309.01.16	E3 - 30 × 2 - 16	30	2 - 16 (OZ 16)	68	43	28	30	57	22
309.01.25	E3 - 30 × 2 - 25	30	2 - 25 (OZ 25)	68	60	28	30	75	22
409.01.25	E3 - 40 × 2 - 25	40	2 - 25 (OZ 25)	83	60	32,5	41,5	75	22
409.01.32	E3 - 40 × 3 - 32	40	3 - 32 (OZ 32)	83	72	32,5	41,5	90	22
509.01.25	E3 - 50 × 2 - 25	50	2 - 25 (OZ 25)	98	60	35	49	75	30
509.01.32	E3 - 50 × 3 - 32	50	3 - 32 (OZ 32)	98	72	35	49	90	30

Lieferumfang: Mit kugellagerter Spannmutter
Delivery: With ball bearing clamping nut
Livraison: Avec écrou de serrage à roulement à billes

7



Collet chucks form E4 for collets DIN 6499 (ISO 15488) ER-system

Mandrins à pinces forme E4 pour pinces DIN 6499 (ISO 15488) système ER



Verwendung:
Zur Aufnahme von Werkzeugen mit
Zylinderschaft in Spannzangen.

Application:
For mounting straight-shank tools in
collets.

Application:
Pour le serrage d'outils avec queue
cylindrique dans des pinces de serrage.

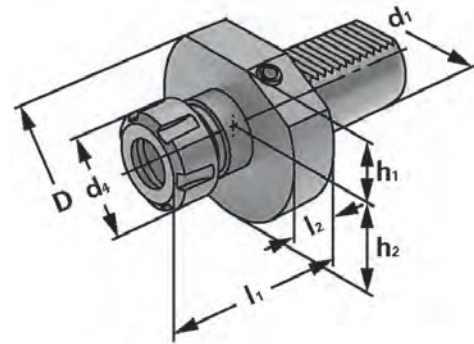
ISO 10889
DIN 69880

E4

14.04

Bestell-Nr. Order no. Référence	Abmessung Size Dimension	d ₁	Spannbereich Capacity Capacité	D	d ₄	h ₁	h ₂	l ₁	l ₂
169.02.10	E4 - 16 × 1 - 10	16	1 - 10 (ER 16)	40	28	18	18	40	13
209.02.10	E4 - 20 × 1 - 10	20	1 - 10 (ER 16)	50	28	25	23	42	18
209.02.16	E4 - 20 × 2 - 16	20	2 - 16 (ER 25)	50	42	25	23	46	18
259.02.16	E4 - 25 × 2 - 16	25	2 - 16 (ER 25)	58	42	25	25	55	18
259.02.20	E4 - 25 × 2 - 20	25	2 - 20 (ER 32)	58	50	25	25	55	18
309.02.16	E4 - 30 × 2 - 16	30	2 - 16 (ER 25)	68	42	28	30	57	22
309.02.20	E4 - 30 × 2 - 20	30	2 - 20 (ER 32)	68	50	28	30	75	22
309.02.26	E4 - 30 × 3 - 26	30	3 - 26 (ER 40)	68	63	28	30	75	22
409.02.16	E4 - 40 × 2 - 16	40	2 - 16 (ER 25)	83	42	32,5	41,5	75	22
409.02.20	E4 - 40 × 2 - 20	40	2 - 20 (ER 32)	83	50	32,5	41,5	75	22
409.02.26	E4 - 40 × 3 - 26	40	3 - 26 (ER 40)	83	63	32,5	41,5	75	22
509.02.26	E4 - 50 × 3 - 26	50	3 - 26 (ER 40)	98	63	35	49	75	30

Lieferumfang: Mit gewuchteter Spannmutter
Delivery: With balanced clamping nut
Livraison: Avec écrou de serrage équilibré



**Verwendung:**

Zur Aufnahme von allen nach DIN 6595 genormten Vollbohrern mit Zylinderschaft.

Application:

For all solid drills with cylindrical shank according to DIN 6595.

Application:

Pour le serrage de forets à queue cylindrique suivant DIN 6595.

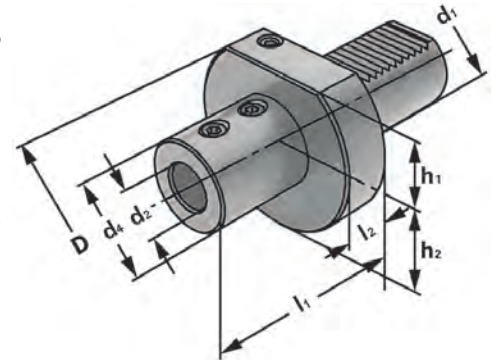
ISO 10889
DIN 69880

E1

Bestell-Nr. Order no. Référence	Abmessung Size Dimension	d ₁	d ₂	d ₄	D	h ₁	h ₂	l ₁	l ₂
209.51.16	E1 - 20 × 16	20	16	40	50	22	22	67	18
209.51.20	E1 - 20 × 20	20	20	40	50	22	22	67	18
209.51.25	E1 - 20 × 25	20	25	45	50	22	22	71	18
259.51.16	E1 - 25 × 16	25	16	40	58	25	25	67	18
259.51.20	E1 - 25 × 20	25	20	40	58	25	25	67	18
259.51.25	E1 - 25 × 25	25	25	45	58	25	25	71	18
259.51.32	E1 - 25 × 32	25	32	58	58	25	25	78	-
309.51.16	E1 - 30 × 16	30	16	36	68	28	30	64	22
309.51.20	E1 - 30 × 20	30	20	40	68	28	30	67	22
309.51.25	E1 - 30 × 25	30	25	45	68	28	30	71	22
309.51.32	E1 - 30 × 32	30	32	52	68	28	30	75	22
309.51.40	E1 - 30 × 40	30	40	60	68	28	30	95	22
409.51.16	E1 - 40 × 16	40	16	36	83	32,5	41,5	64	22
409.51.20	E1 - 40 × 20	40	20	40	83	32,5	41,5	67	22
409.51.25	E1 - 40 × 25	40	25	45	83	32,5	41,5	75	22
409.51.32	E1 - 40 × 32	40	32	52	83	32,5	41,5	75	22
409.51.40	E1 - 40 × 40	40	40	65	83	32,5	41,5	90	22
509.51.16	E1 - 50 × 16	50	16	40	98	35	49	66	30
509.51.20	E1 - 50 × 20	50	20	40	98	35	49	66	30
509.51.25	E1 - 50 × 25	50	25	45	98	35	49	80	30
509.51.32	E1 - 50 × 32	50	32	52	98	35	49	80	30
509.51.40	E1 - 50 × 40	50	40	65	98	35	49	90	30
509.51.50	E1 - 50 × 50	50	50	75	98	35	49	100	30

Lieferumfang: Mit Spannschrauben
 Delivery: With clamping screws
 Livraison: Avec vis de serrage

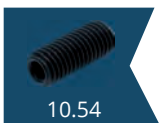

10.54



Drill chuck adaptors DIN 238

Arbres pour mandrins de perçage DIN 238

DIN 69880 (VDI 3425)



Verwendung:
Zur Aufnahme von Bohrfuttern.

Application:
For mounting drill chucks.

Application:
Pour le serrage de mandrins de perçage.

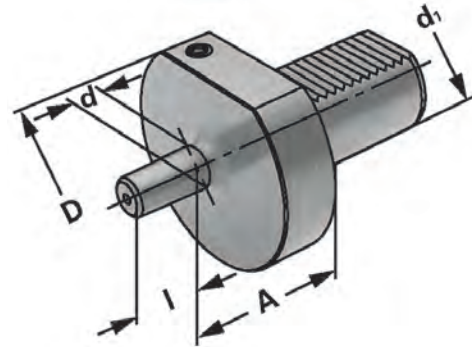
ISO 10889
DIN 69880

DIN 238

Bestell-Nr. Order no. Référence	Abmessung Size Dimension	d_1	d	D	A	l
309.14.16	30 - B16	30	B16	68	27	24
409.14.16	40 - B16	40	B16	83	27	24
509.14.16	50 - B16	50	B16	98	35	24





Verwendung:
Für Innenbearbeitung mit Bohrstangen.
Application:
For internal machining with boring bars.
Application:
Pour l'usinage intérieur avec barres d'alésage.

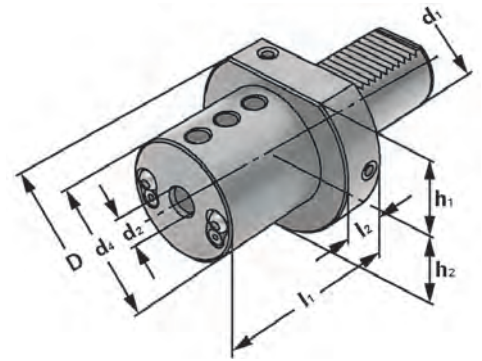

ISO 10889
DIN 69880

E2

Bestell-Nr. Order no. Référence	Abmessung Size Dimension	d ₁	d ₂	D	d ₄	h ₁	h ₂	l ₁	l ₂
169.52.06	E2 – 16 × 06	16	6	40	32	18	20	44	13
169.52.08	E2 – 16 × 08	16	8	40	32	18	20	44	13
169.52.10	E2 – 16 × 10	16	10	40	32	18	20	44	13
169.52.12	E2 – 16 × 12	16	12	40	32	18	20	44	13
169.52.16	E2 – 16 × 16	16	16	40	32	18	20	44	13
209.52.08	E2 – 20 × 08	20	8	50	40	23	25	50	18
209.52.10	E2 – 20 × 10	20	10	50	40	23	25	50	18
209.52.12	E2 – 20 × 12	20	12	50	40	23	25	50	18
209.52.16	E2 – 20 × 16	20	16	50	40	23	25	50	18
209.52.20	E2 – 20 × 20	20	20	50	40	23	25	50	18
259.52.08	E2 – 25 × 08	25	8	58	40	-	25	50	18
259.52.10	E2 – 25 × 10	25	10	58	40	-	25	50	18
259.52.12	E2 – 25 × 12	25	12	58	40	-	25	50	18
259.52.16	E2 – 25 × 16	25	16	58	40	-	25	50	18
259.52.20	E2 – 25 × 20	25	20	58	58	-	25	50	-
259.52.25	E2 – 25 × 25	25	25	58	58	-	25	60	-



Ausführung: Mit einstellbaren Kugelspritzdüsen
Version: With adjustable spray nozzles
Version: Avec gicleurs ajustables

Lieferumfang: Mit Spannschrauben
Delivery: With clamping screws
Livraison: Avec vis de serrage



Boring bar holders form E2

DIN 69880 (VDI 3425)

Porte-outils pour barres d'alésage forme E2



Verwendung:
Für Innenbearbeitung mit Bohrstangen.

Application:
For internal machining with boring bars.

Application:
Pour l'usinage intérieur avec barres d'alésage.

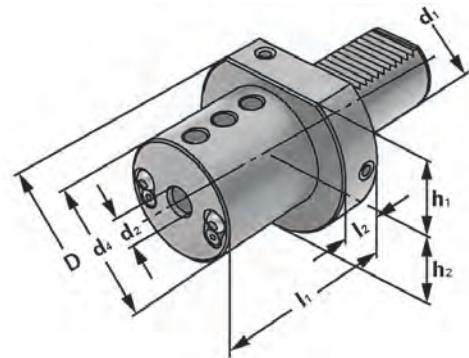
ISO 10889
DIN 69880

E2

Bestell-Nr. Order no. Référence	Abmessung Size Dimension	d ₁	d ₂	D	d ₄	h ₁	h ₂	l ₁	l ₂
309.52.08	E2 - 30 × 08	30	8	68	55	28	30	60	22
309.52.10	E2 - 30 × 10	30	10	68	55	28	30	60	22
309.52.12	E2 - 30 × 12	30	12	68	55	28	30	60	22
309.52.16	E2 - 30 × 16	30	16	68	55	28	30	60	22
309.52.20	E2 - 30 × 20	30	20	68	55	28	30	60	22
309.52.25	E2 - 30 × 25	30	25	68	55	28	30	60	22
309.52.32	E2 - 30 × 32	30	32	68	68	28	30	75	-
409.52.08	E2 - 40 × 08	40	8	83	55	32,5	41,5	75	22
409.52.10	E2 - 40 × 10	40	10	83	55	32,5	41,5	75	22
409.52.12	E2 - 40 × 12	40	12	83	55	32,5	41,5	75	22
409.52.16	E2 - 40 × 16	40	16	83	55	32,5	41,5	75	22
409.52.20	E2 - 40 × 20	40	20	83	55	32,5	41,5	75	22
409.52.25	E2 - 40 × 25	40	25	83	55	32,5	41,5	75	22
409.52.32	E2 - 40 × 32	40	32	83	83	32,5	41,5	75	-
409.52.40	E2 - 40 × 40	40	40	83	83	32,5	41,5	90	-
509.52.12	E2 - 50 × 12	50	12	98	68	35	49	90	30
509.52.16	E2 - 50 × 16	50	16	98	68	35	49	90	30
509.52.20	E2 - 50 × 20	50	20	98	68	35	49	90	30
509.52.25	E2 - 50 × 25	50	25	98	68	35	49	90	30
509.52.32	E2 - 50 × 32	50	32	98	68	35	49	90	30
509.52.40	E2 - 50 × 40	50	40	98	98	35	49	90	-
509.52.50	E2 - 50 × 50	50	50	98	98	35	49	100	-

Ausführung: Mit einstellbaren Kugelspritzdüsen
Version: With adjustable spray nozzles
Version: Avec gicleurs ajustables

Lieferumfang: Mit Spannschrauben
Delivery: With clamping screws
Livraison: Avec vis de serrage





Verwendung:
 Reduzierung zum Spannen von Werkzeugen mit Zylinderschaft, wie z. B. Feindreh-Bohrstangen.

Application:
 Reduction for mounting tools with straight-shank, such as precision boring bars.

Application:
 Réduction pour le serrage d'outils avec queue cylindrique, p. ex. barres d'alésage pour tournage de finition.

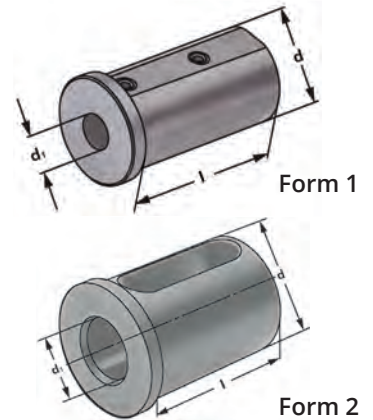

Bestell-Nr. Order no. Référence	Form form forme	d	d ₁	l
709.25.06	1	25	6	46
709.25.08	1	25	8	46
709.25.10	1	25	10	46
709.25.12	1	25	12	46
709.25.14	1	25	14	46
709.25.16	2	25	16	46
709.25.18	2	25	18	46
709.25.20	2	25	20	46
709.32.06	1	32	6	56
709.32.08	1	32	8	56
709.32.10	1	32	10	56
709.32.12	1	32	12	56
709.32.14	1	32	14	56
709.32.16	2	32	16	56
709.32.18	2	32	18	56
709.32.20	2	32	20	56
709.32.25	2	32	25	56

Hinweis: Geeignet für Innenkühlung (nicht geschlitzt)
Note: Suitable for through-coolant (not slotted)
Observation: Convenable pour arrosage interne (non fendu)



Reduction sleeves for boring bar holders form E2
 Douilles de réduction pour barres d'alésage forme E2

DIN 69880 (VDI 3425)



Form 1



Form 2

Verwendung:
 Reduzierung zum Spannen von Werkzeugen mit Zylinderschaft, wie z. B. Feindreh-Bohrstangen.

Application:
 Reduction for mounting tools with straight-shank, such as precision boring bars.

Application:
 Réduction pour le serrage d'outils avec queue cylindrique, p. ex. barres d'alésage pour tournage de finition.

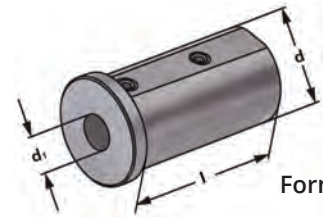

Form 1

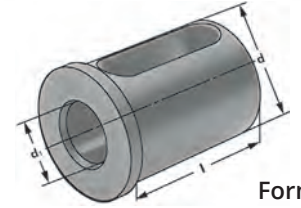

Form 2

Bestell-Nr. Order no. Référence	Form form forme	d	d ₁	l
709.40.06	1	40	6	71
709.40.08	1	40	8	71
709.40.10	1	40	10	71
709.40.12	1	40	12	71
709.40.14	1	40	14	71
709.40.16	2	40	16	71
709.40.18	2	40	18	71
709.40.20	2	40	20	71
709.40.25	2	40	25	71
709.40.32	2	40	32	71

Hinweis: Geeignet für Innenkühlung (nicht geschlitzt)
Note: Suitable for through-coolant (not slotted)
Observation: Convenable pour arrosage interne (non fendu)





Verwendung:
Zur Aufnahme von Werkzeugen mit Morsekegelschaft und Austreibblappen nach DIN 228-1 Form B.

Application:
For holding tools with Morse taper shank and tang according to DIN 228-1 form B.

Application:
Pour le serrage d'outils avec queue cône Morse et tenon suivant DIN 228-1 forme B.

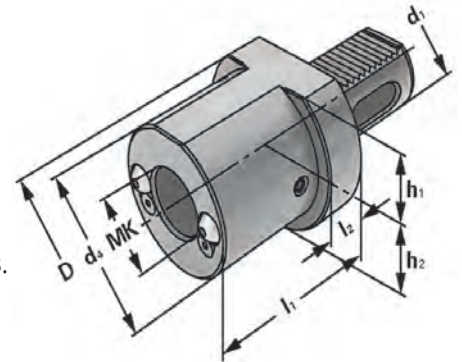

ISO 10889
DIN 69880

F1

Bestell-Nr. Order no. Référence	Abmessung Size Dimension	d ₁	MK MT CM	d ₄	D	l ₁	l ₂	h ₁	h ₂
169.07.01	F1 - 16 × MK 1	16	1	32	40	32	13	18	18
209.07.01	F1 - 20 × MK 1	20	1	-	50	23	-	22	23
209.07.02	F1 - 20 × MK 2	20	2	40	50	90	-	22	23
259.07.01	F1 - 25 × MK 1	25	1	-	58	23	-	25	25
259.07.02	F1 - 25 × MK 2	25	2	-	58	27	-	25	25
309.07.01	F1 - 30 × MK 1	30	1	-	68	27	-	28	30
309.07.02	F1 - 30 × MK 2	30	2	-	68	27	-	28	30
309.07.03	F1 - 30 × MK 3	30	3	58	68	75	22	28	30
409.07.02	F1 - 40 × MK 2	40	2	55	83	36	22	32,5	50,5
409.07.03	F1 - 40 × MK 3	40	3	55	83	36	22	32,5	50,5
409.07.04	F1 - 40 × MK 4	40	4	68	83	80	22	32,5	50,5
509.07.02	F1 - 50 × MK 2	50	2	55	98	36	30	35	49
509.07.03	F1 - 50 × MK 3	50	3	58	98	36	30	35	49
509.07.04	F1 - 50 × MK 4	50	4	68	98	50	30	35	49
509.07.05	F1 - 50 × MK 5	50	5	98	98	168	-	35	49

Ausführung: Mit einstellbaren Kugelspritzdüsen
Version: With adjustable spray nozzles
Version: Avec gicleurs ajustables





Verwendung:
Zur Aufnahme von Werkzeugen mit Zylinderschaft nach DIN 1835 Form A+B+E und DIN 6535 Form HA+HB+HE (größer Ø 20 mm nur mit Reduzierung).

Application:
For mounting straight-shank tools acc. DIN 1835 form A+B+E and DIN 6535 form HA+HB+HE (larger than Ø 20 mm only with reduction sleeve).

Application:
Pour le serrage d'outils avec queue cylindrique suivant DIN 1835 forme A+B+E et DIN 6535 forme HA+HB+HE (à partir de Ø 20 mm seulement avec réduction).

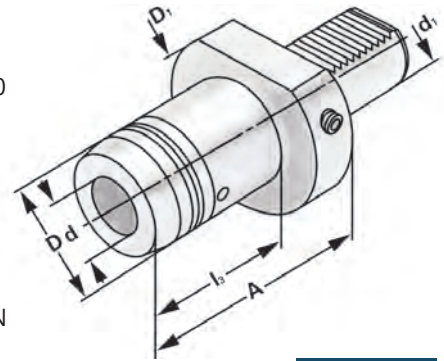

ISO 10889
DIN 69880

14.04

Bestell-Nr. Order no. Référence	Abmessung Size Dimension	d ₁	d	D	A	l ₃	D ₁
309.H06	30 - 06	30	6	26	49	33	68
309.H08	30 - 08	30	8	28	49	33	68
309.H10	30 - 10	30	10	30	49	33	68
309.H12	30 - 12	30	12	32	54	38	68
309.H14	30 - 14	30	14	34	54	38	68
309.H16	30 - 16	30	16	38	89	73	68
309.H18	30 - 18	30	18	40	89	73	68
309.H20	30 - 20	30	20	42	89	73	68
309.H25	30 - 25	30	25	50	94	78	68
309.H32	30 - 32	30	32	60	94	78	68
409.H06	40 - 06	40	6	26	55	33	83
409.H08	40 - 08	40	8	28	55	33	83
409.H10	40 - 10	40	10	30	55	33	83
409.H12	40 - 12	40	12	32	60	38	83
409.H14	40 - 14	40	14	34	80	38	83
409.H16	40 - 16	40	16	38	90	73	83
409.H18	40 - 18	40	18	40	60	73	83
409.H20	40 - 20	40	20	42	95	73	83
409.H25	40 - 25	40	25	50	95	73	83
409.H32	40 - 32	40	32	60	95	73	83
509.H06	50 - 06	50	6	26	55	33	98
509.H08	50 - 08	50	8	28	55	33	98
509.H10	50 - 10	50	10	30	55	33	98
509.H12	50 - 12	50	12	32	60	38	98
509.H14	50 - 14	50	14	34	60	38	98
509.H16	50 - 16	50	16	38	95	65	98
509.H18	50 - 18	50	18	40	95	65	98
509.H20	50 - 20	50	20	42	95	65	98
509.H25	50 - 25	50	25	50	95	65	98
509.H32	50 - 32	50	32	60	95	65	98

Lieferumfang: Mit Spannschlüssel
Delivery: With wrench
Livraison: Avec clé de serrage





Verwendung:
Zum Verschließen der Aufnahmebohrung
am Werkzeugrevolver.

Application:
For sealing the spindle of the turret.

Application:
Pour boucher la broche du tour.

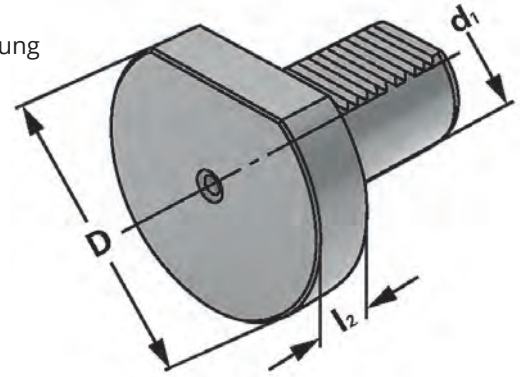

ISO 10889
DIN 69880

Z2

Bestell-Nr. Order no. Référence	Abmessung Size Dimension	d ₁	D	l ₂
169.29.13	Z2 - 16 × 13	16	40	13
209.29.16	Z2 - 20 × 16	20	50	16
259.29.16	Z2 - 25 × 16	25	58	16
309.29.20	Z2 - 30 × 16	30	68	16
409.29.20	Z2 - 40 × 20	40	83	20
509.29.20	Z2 - 50 × 20	50	98	20



Verwendung:
Zum Verschließen der Aufnahmebohrung
am Werkzeugrevolver.

Application:
For sealing the spindle of the turret.

Application:
Pour boucher la broche du tour.

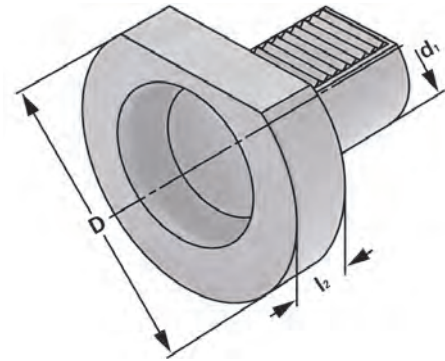

ISO 10889
DIN 69880

Z2

Bestell-Nr. Order no. Référence	Abmessung Size Dimension	d ₁	D	l ₂
169.30.13	Z2 - 16 × 13	16	40	13
209.30.16	Z2 - 20 × 16	20	50	16
259.30.16	Z2 - 25 × 16	25	58	16
309.30.16	Z2 - 30 × 16	30	68	16
409.30.20	Z2 - 40 × 20	40	83	20
509.30.20	Z2 - 50 × 20	50	98	20



Verwendung:
Zur Aufnahme von Werkzeugen mit Zylinderschaft.
Application:
For mounting tools with straight shank.
Application:
Pour le serrage d'outils avec queue cylindrique.

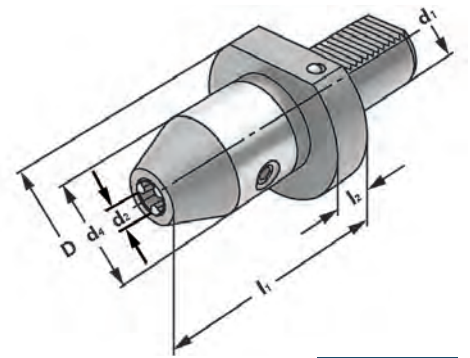

ISO 10889
DIN 69880

$\nearrow \leq 0,030$

14.04

Bestell-Nr. Order no. Référence	d ₁	Spannbereich Capacity Capacité	d ₂	d ₄	D	l ₁	l ₂
209.15.13	20	1,0 - 13		50	50	88	17
309.15.13	30	1,0 - 13		50	68	93	22
309.15.16	30	2,5 - 16		50	68	98	22
409.15.13	40	1,0 - 13		50	83	93	22
409.15.16	40	2,5 - 16		50	83	98	22
509.15.13	50	1,0 - 13		50	98	101	30
509.15.16	50	2,5 - 16		50	98	106	30

7

Hinweis: Hohe Präzision und Rundlaufgenauigkeit von $\leq 0,03$ mm. Sichere Spannung des Werkzeuges durch mechanische Spannkraftverstärkung. Kein selbständiges Lösen der Spannung während der Bearbeitung bei Links- oder Rechtslauf. Spannen und Lösen mit Sechskantschlüssel.

Note: High precision and accurate concentricity of ≤ 0.03 mm. Secure gripping of the tool through mechanical amplification of the clamping force. No automatic slackening of the clamping force while machining with either clockwise or counter clockwise rotation. Clamping and releasing effected by means of an Allen wrench.

Observation: Précision élevée et exactitude de circularité de $\leq 0,03$ mm. Serrage sûr de l'outil grâce à l'amplification de la force de serrage. Pas de desserrage intempestif en cours d'usinage lors de la rotation la gauche ou la droite. Serrage et desserrage en utilisant un clé sur à fourche.

Lieferumfang: Mit Spannschlüssel
Delivery: With wrench
Livraison: Avec clé de serrage



10.23



CNC-Drill chucks with coolant supply via spray nozzles
Mandrins de perçage CNC avec arrosage par gicleurs

DIN 69880 (VDI 3425)



Verwendung:
Zur Aufnahme von Werkzeugen mit Zylinderschaft.
Application:
For mounting tools with straight shanks.
Application:
Pour le serrage d'outils à queue cylindrique.

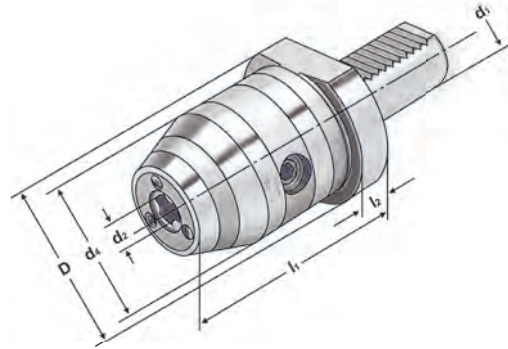

ISO 10889
DIN 69880

$\nearrow \leq 0,030$

14.04

Bestell-Nr. Order no. Référence	d ₁	Spannbereich Capacity Capacité	d ₄	D	l ₁	l ₂
169.15.10.K	16	0,3 - 10	40	40	46	10
209.15.10.K	20	0,3 - 10	50	50	41	10
259.15.13.K	25	1,0 - 13	50	55	87	12
309.15.13.K	30	1,0 - 13	50	68	87	22
309.15.16.K	30	2,5 - 16	55	68	92	22
409.15.13.K	40	1,0 - 13	50	83	88	22
409.15.16.K	40	2,5 - 16	55	83	93	22
509.15.16.K	50	2,5 - 16	55	98	102	



Hinweis: Hohe Präzision und Rundlaufgenauigkeit von $\leq 0,03$ mm. Sichere Spannung des Werkzeuges durch mechanische Spannkraftverstärkung. Kein selbständiges Lösen der Spannung während der Bearbeitung bei Links- oder Rechtslauf. Spannen und Lösen mit Sechskantschlüssel.

Note: High precision and accurate concentricity of ≤ 0.03 mm. Secure gripping of the tool through mechanical amplification of the clamping force. No automatic slacking of the clamping force while machining with either clockwise or counter clockwise rotation. Clamping and releasing effected by means of an Allen wrench.

Observation: Précision élevée et exactitude de circularité de $\leq 0,03$ mm. Serrage sûr de l'outil grâce à l'amplification de la force de serrage. Pas de desserrage intempestif en cours d'usinage lors de la rotation la gauche ou la droite. Serrage et desserrage en utilisant un clé sur à fourche.

Lieferumfang: Mit Spannschlüssel
Delivery: With wrench
Livraison: Avec clé de serrage





Quick change tapping chucks with length compensation on compression and expansion

Mandrins de taraudage à changement rapide avec compensation longitudinale à la compression et traction



Verwendung:

Zur Aufnahme von Schnellwechsel-Einsätzen für Gewindebohrer.

Application:

For the chucking of Quick change taps for threading taps.

Application:

Pour le serrage des inserts de changement rapide pour tarauds.

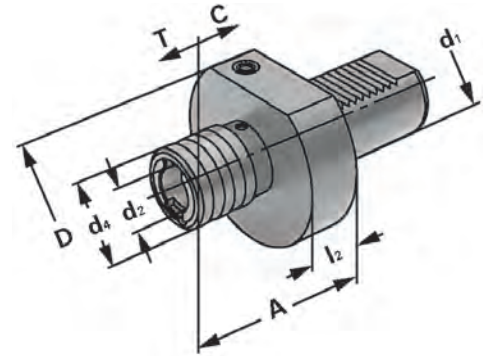

ISO 10889
DIN 69880



Bestell-Nr. Order no. Référence	d ₁	Spannbereich Capacity Capacité	Größe Size Taille	D	A	d ₄	d ₂	C	T
209.16.12	20	M3 - M14	1	50	67	38	19	7	7
259.16.12	25	M3 - M14	1	58	55	38	19	7	7
309.16.12	30	M3 - M14	1	58	58	36	19	7	7
309.16.20	30	M5 - M22	2	81	81	53	31	12	12
409.16.12	40	M3 - M14	1	58	58	36	19	7	7
409.16.20	40	M5 - M22	2	81	81	53	31	12	12
509.16.12	50	M3 - M14	1	58	56	36	19	7	7
509.16.20	50	M5 - M22	2	81	80	53	31	12	12





ohne Längenausgleich auf Druck und Zug

DIN 69880 (VDI 3425)

Quick change tapping chucks without length compensation on compression and expansion
 Mandrins de taraudage à changement rapide sans compensation longitudinale à la compression et traction



Verwendung:
 Für Bearbeitungszentren mit Synchronspindel. Zur Aufnahme von Schnellwechsel-Einsätzen für Gewindebohrer.

Application:
 On machining centres with synchronised spindles. For the chucking of Quick change taps for threading taps.

Application:
 Sur centres d'usinage avec axe synchrone. Pour le serrage des inserts de changement rapide pour tarauds.

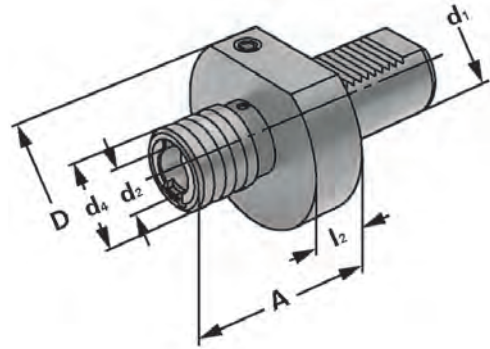

ISO 10889
 DIN 69880



Bestell-Nr. Order no. Référence	d ₁	Spannbereich Capacity Capacité	Größe Size Taille	D	A	d ₄	d ₂
309.16.12.1	30	M3 - M14	1	68	55	36	19
309.16.20.1	30	M5 - M22	2	68	77	53	31
409.16.12.1	40	M3 - M14	1	83	55	36	19
409.16.20.1	40	M5 - M22	2	83	77	53	31





Verwendung:
Zur Herstellung von Sonderwerkzeugen.
Application:
For the manufacturing of special tools.
Application:
Pour la fabrication d'outils spéciaux.

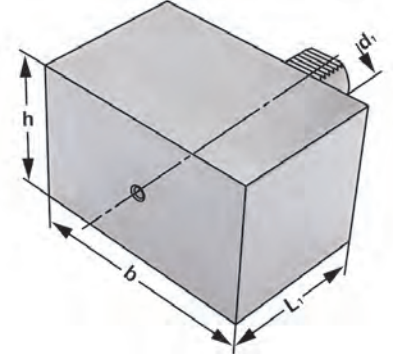

ISO 10889
DIN 69880

A1

Bestell-Nr. Order no. Référence	Abmessung Size Dimension	d ₁	L ₁	h	b
169.17.12	A1 - 16 - 78 - 44 - 44	16	44	44	78
209.17.16	A1 - 20 - 100 - 60 - 65	20	65	60	100
259.17.16	A1 - 25 - 100 - 60 - 75	25	75	60	100
309.17.20	A1 - 30 - 130 - 76 - 85	30	85	76	130
409.17.25	A1 - 40 - 151 - 96 - 100	40	100	96	151
509.17.32	A1 - 50 - 160 - 120 - 125	50	125	120	160





Soft blank fomr A2, round
Porte-outils ebauche forme A2, ronde



Verwendung:
Zur Herstellung von Sonderwerkzeugen.
Application:
For the manufacturing of special tools.
Application:
Pour la fabrication d'outils spéciaux.

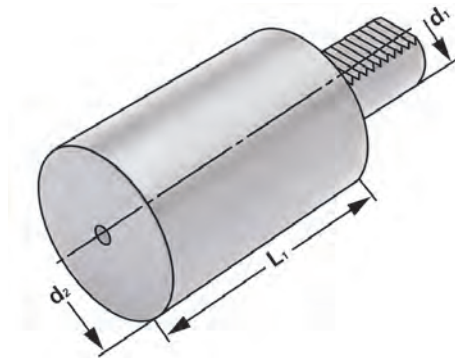

ISO 10889
DIN 69880

A2

Bestell-Nr. Order no. Référence	Abmessung Size Dimension	d ₁	d ₂	L ₁
169.19.12	A2 - 16 - 40 - 60	16	40	60
209.19.16	A2 - 20 - 50 - 70	20	50	70
259.19.16	A2 - 25 - 50 - 80	25	58	80
259.19.17	A2 - 25 - 50 - 200	25	58	200
309.19.20	A2 - 30 - 68 - 100	30	68	100
309.19.21	A2 - 30 - 68 - 240	30	68	240
409.19.20	A2 - 40 - 83 - 120	40	83	120
409.19.21	A2 - 40 - 83 - 320	40	83	320
509.19.32	A2 - 50 - 98 - 135	50	98	135
509.19.33	A2 - 50 - 98 - 400	50	98	400



Verwendung:
Zur Abnahme von Werkzeugmaschinen gemäß ISO-Empfehlung R230 oder zur Überprüfung der Werkzeugspindel.

Application:
For the inspection of machine tools according to ISO recommendation R230 or for testing the tool spindle.

Application:
Pour l'inspection de machine-outils suite à la recommandation ISO R230 ou pour la vérification de la broche.

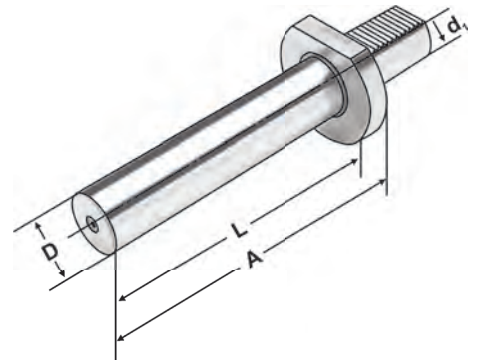

ISO 10889
DIN 69880

$\nabla \leq 0,003$

Bestell-Nr. Order no. Référence	Abmessung Size Dimension	d ₁	D	A	L
169.18.30	16 - 30 - 120	16	30	120	105
209.18.40	20 - 40 - 150	20	40	150	130
259.18.40	25 - 40 - 150	25	40	150	135
309.18.40	30 - 40 - 200	30	40	230	185
409.18.40	40 - 40 - 200	40	40	200	185
509.18.40	50 - 40 - 200	50	40	200	185

7

Holzkasten für Kontrolldorne

Wooden box for test arbors

Coffret en bois pour mandrins de contrôle



Verwendung:
Zur Aufbewahrung von Kontrolldornen.

Application:
For the storage of test arbors.

Application:
Pour la conservation de mandrins de contrôle.



Bestell-Nr.
Order no.
Référence

Abmessung
Size
Dimension

für Kegelgrößen
for cones
pour cônes

701.18

460 × 130 × 115

VDI 16 / 20 / 25 / 30 / 40 / 50

Shims
Sous-plaquettes



Verwendung:
Unterlegplatten für VDI Werkzeughalter
Application:
Shims for VDI toolholder
Application:
Assiettes pour porte-outils VDI

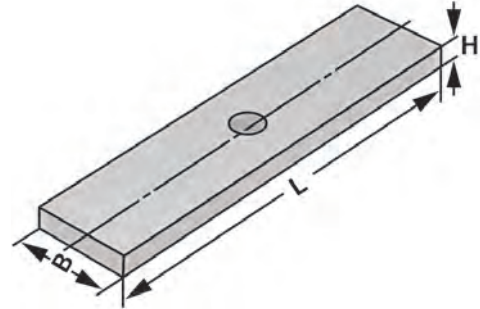

Bestell-Nr. Order no. Référence	B	H	L
209.16.01	14	4	54
259.16.01	13,5	4	49
309.20.01	16	4	69
409.25.01	20	5	84
509.32.01	23	7	99



O-Ringe

O-ring
Joints torique



Verwendung:
O-Ringe zum abdichten des VDI Schaftes
Application:
O-Rings for sealing VDI shanks
Application:
Joints toriques pour étancher des queues VDI

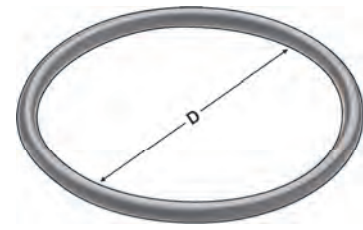

Bestell-Nr. Order no. Référence	D
Z.169.RING	16
Z.209.RING	20
Z.259.RING	25
Z.309.RING	30
Z.409.RING	40
Z.509.RING	50



Verwendung:
Spritzdüsen für Kühlmittelzufuhr für VDI
Werkzeughalter

Application:
Sprayer nozzles for cooling by VDI toolholders

Application:
Gicleurs pour l'alimentation en refroidisse-
ment pour porte-outils VDI

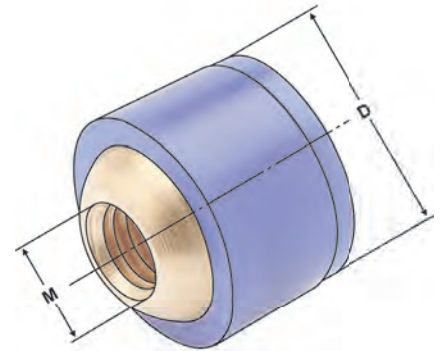

Bestell-Nr. Order no. Référence	D	M
703.08	8	3
703.10	10	4
703.12	12	5
703.14	14	6





Ball sprayer nozzles (brass)
Gicleurs (laiton)



Verwendung:
Spritzdüsen für Kühlmittelzufuhr für VDI Werkzeughalter

Application:
Sprayer nozzles for cooling by VDI toolholders

Application:
Gicleurs pour l'alimentation en refroidissement pour porte-outils VDI

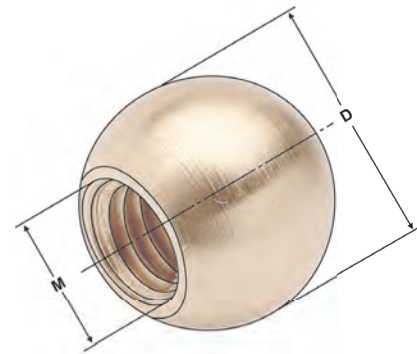

Bestell-Nr. Order no. Référence	D	M	VDI
703.08.ME	8	5	16
703.10.ME	10	6	16 + 25 + 30 + 40
703.12.ME	12	6	50
703.14 .ME	14	8	



Kühlmittelrohr (Messing)

Coolant tube (brass)
Canule de lubrification (laiton)



Verwendung:
Kühlmittelrohr für Kühlmittelzufuhr für VDI Werkzeughalter

Application:
Coolant tube for cooling by VDI toolholders

Application:
Canule de lubrification pour l'alimentation en refroidissement pour porte-outils VDI

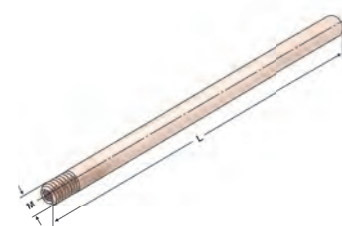

Bestell-Nr. Order no. Référence	L	M	Ø
Z.VDI.700.200	100	5	Ø 3mm
Z.VDI.700.100	100	6	Ø 3mm



Static and power-driven tools for HAAS BMT 65
Porte-outils statiques ou rotatifs pour HAAS BMT 65

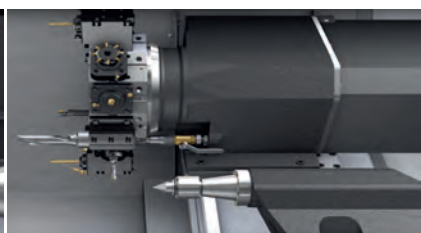



Toolholder with square-longitudinal receptacle doubled
 Manche à outils avec porte-outils longitudinal carré double

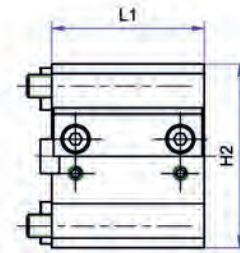
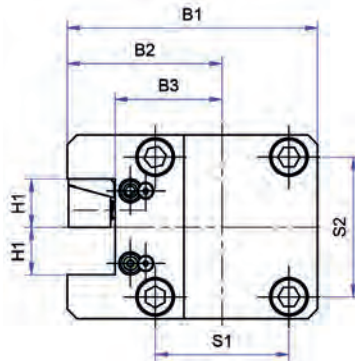
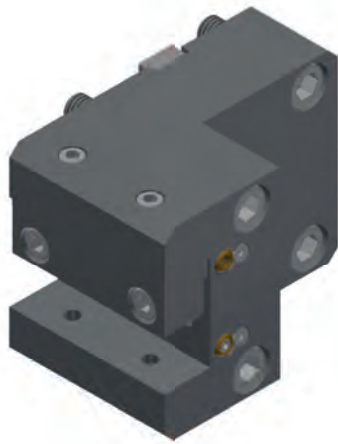

HAAS ST-Line BMT 65 EC

Bestell-Nr. Order no. Référence	H1	H2	B1	B2	B3	L1	S1	S2
AW.102.065.25.755	25	96	131	81	56	80	70	73



Zylinderschaftaufnahme

Cylindrical shank receptacle
 Support de tige cylindrique

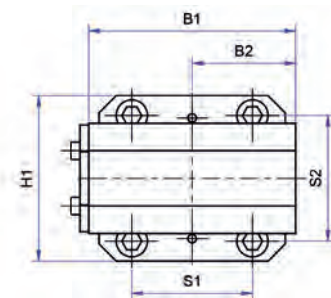
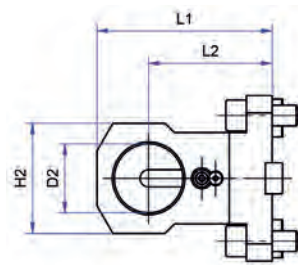

HAAS ST-Line BMT 65 IC | EC

Bestell-Nr. Order no. Référence	D2	H1	H2	B1	B2	L1	L2	S1	S2
AW.107.265.40.750	40	96	64	120	60	102	72	70	73





Front cut-off toolholder

Porte-outils de tronçonnage frontal

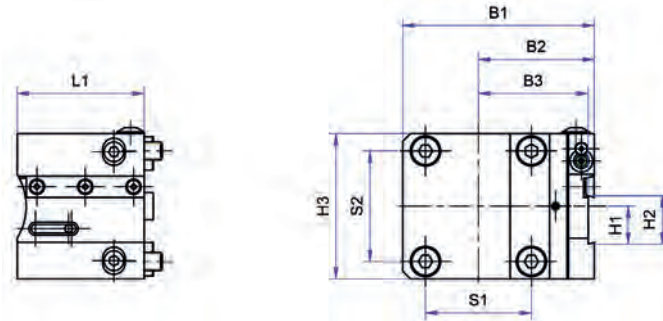
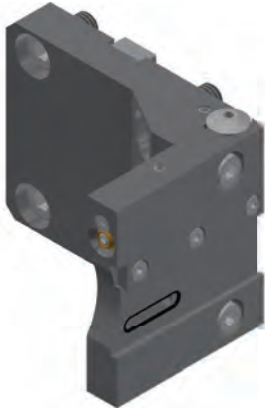

HAAS ST-Line

BMT 65



IC | EC

Bestell-Nr.
Order no.
Référence

AW.105.065.26.753

H1

25

H2

32

H3

96

B1

126,5

B2

76,5

B3

72,5

L1

84

S1

70

S2

73

7

Werkzeughalter mit Vierkant-Mehrfachaufnahme

Toolholder with square-multi-receptacle

Manche à outils avec porte-outils multiple carré

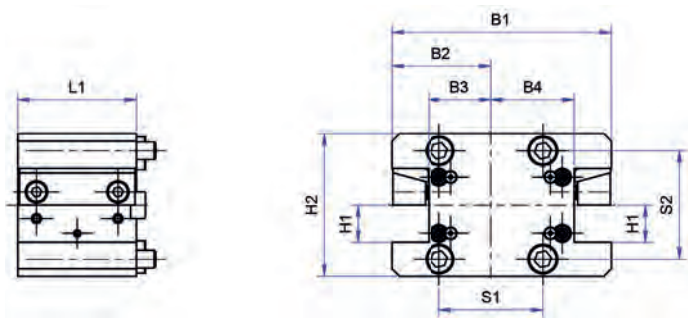

HAAS ST-Line

BMT 65



EC

Bestell-Nr.
Order no.
Référence

AW.103.065.25.755

H1

25

H2

96

B1

149

B2

68

B3

43

B4

56

L1

80

S1

70

S2

73



Toolholder with square-multi-receptacle
Manche à outils avec porte-outils multiple carré

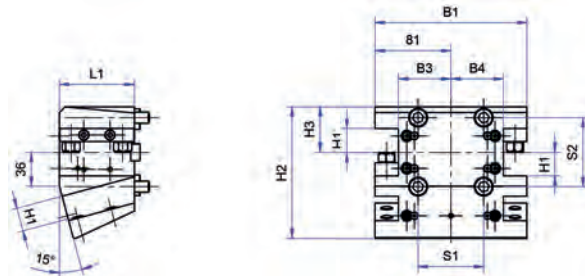
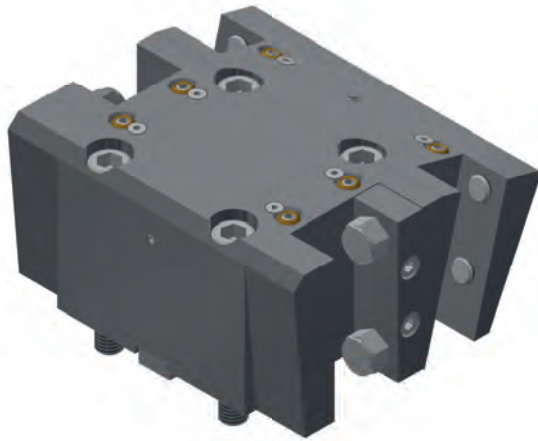

HAAS ST-Line

BMT 65



EC

Bestell-Nr.
Order no.
Référence

	H1	H2	H3	B1	B2	B3	B4	L1	S1	S2
AW.103.065.25.756	25	139,873	48	162	81	56	56	80	70	73

Zylinderschaftaufnahme

Cylindrical shank receptacle
Support de tige cylindrique

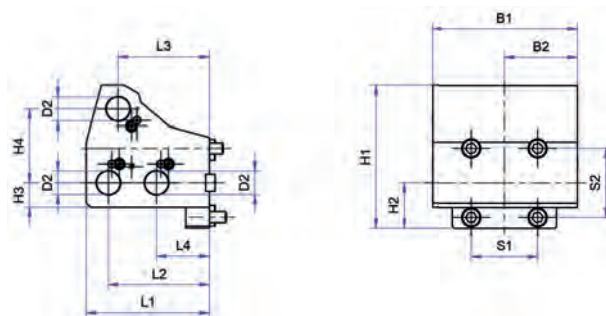

HAAS ST-Line

BMT 65



IC | EC

Bestell-Nr.
Order no.
Référence

	D2	H1	H2	H3	H4	B1	B2	L1	L2	L3	L4	S1	S2
AW.107.265.25.756	25	151	48	26	77,82	154	77	130,5	107	96,755	56	70	73



7.58



Toolholder with square-multi-receptacle
Manche à outils avec porte-outils multiple carré

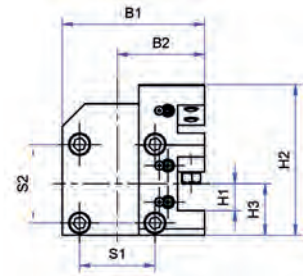
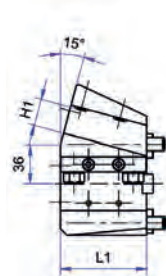
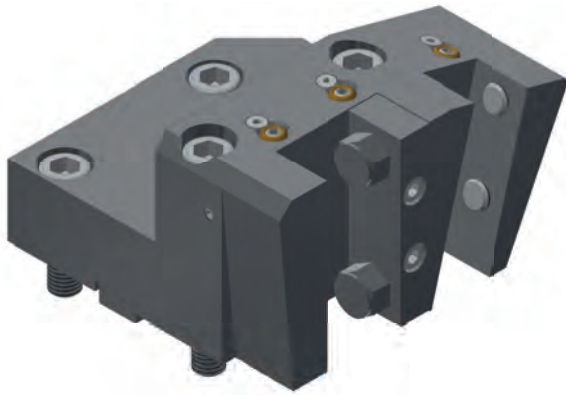

HAAS ST-Line

BMT 65



EC

Bestell-Nr.
Order no.
Référence

	H1	H2	H3	B1	B2	L1	S1	S2
AW.103.065.25.753	25	139,873	48	132	81	80	70	73

7

Zylinderschaftaufnahme

Cylindrical shank receptacle
Support de tige cylindrique

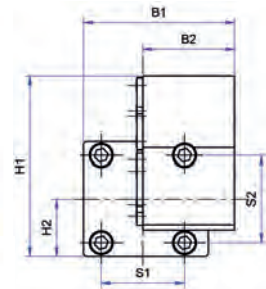
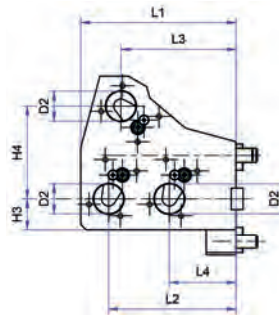

HAAS ST-Line

BMT 65



IC | EC

Bestell-Nr.
Order no.
Référence

	D2	H1	H2	H3	H4	B1	B2	L1	L2	L3	L4	S1	S2
AW.107.265.25.753	25	151	48	26	77,82	127	77	130,5	107	96,755	56	70	73



Axial drilling and milling head for external cooling

Tête d'alésage et de fraisage axiale pour refroidissement externe

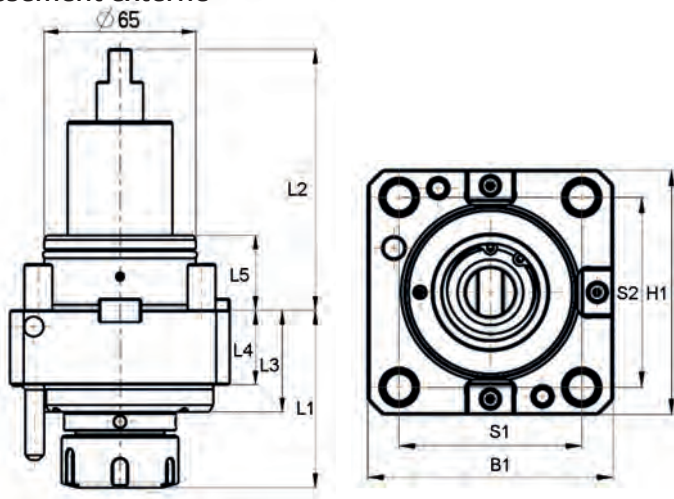
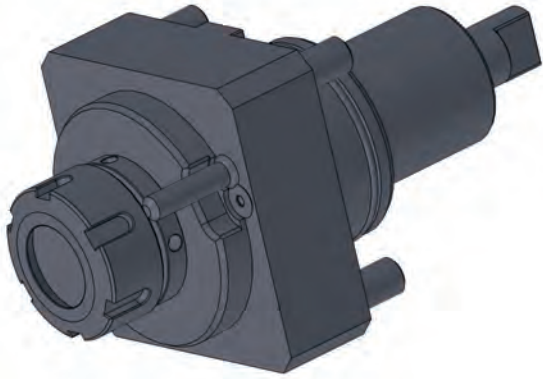

HAAS ST-Line | BMT 65 | EC | ER 32 | 1:1

Bestell-Nr. Order no. Référence	B1	H1	S1	S2	L1	L2	L3	L4	L5	n max. min-1	T max. Nm
AW.221.065.20.751	94	94	70	73	76,3	112	43,7	32	32	6000	70

Radial Bohr- und Fräskopf für externe Kühlung

Radial drilling and milling head for external cooling

Tête d'alésage et de fraisage radiale pour refroidissement externe

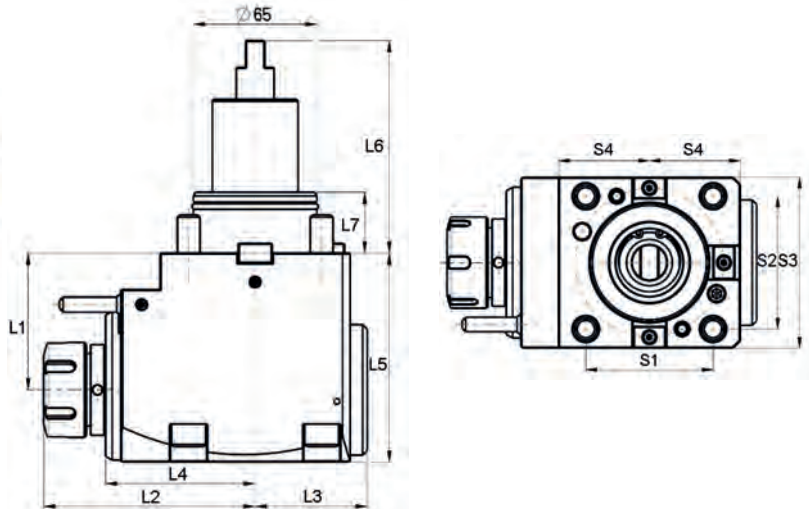
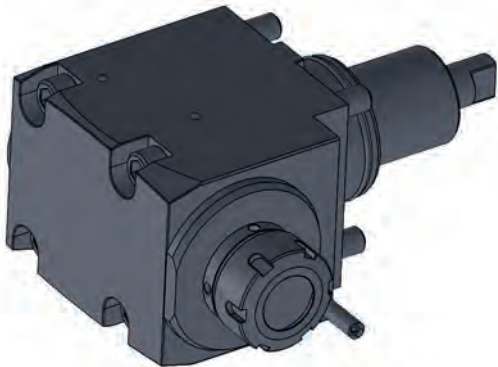

HAAS ST-Line | BMT 65 | EC | ER 32 | 1:1

Bestell-Nr. Order no. Référence	S1	S2	S3	S4	L1	L2	L3	L4	L5	L6	L7	n max. min-1	T max. Nm
AW.221.265.20.751	70	73	94	50	72	111,3	59	78,7	110	112	32	6000	70





Axial drilling and milling head for internal and external cooling

Tête d'alésage et de fraisage axiale pour refroidissement interne et externe

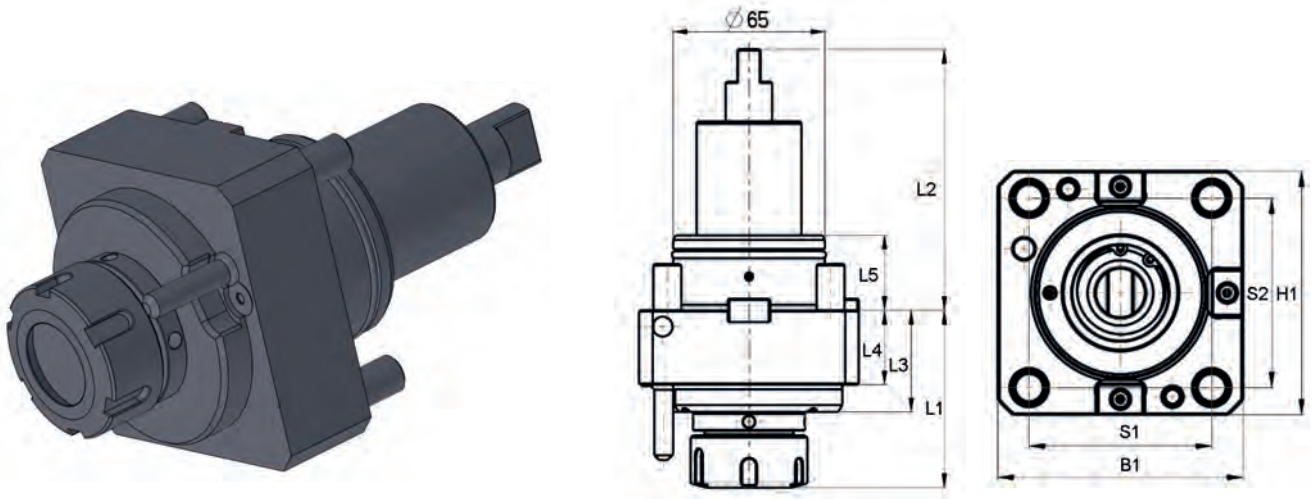

HAAS ST-Line | BMT 65 | IC | EC | ER 32 | 1:1

Bestell-Nr. Order no. Référence	B1	H1	S1	S2	L1	L2	L3	L4	L5	n max. min-1	T max. Nm
AW.221.065.20.756	94	94	70	73	76,3	112	43,7	32	32	6000	70



Radial Bohr- und Fräskopf für interne und externe Kühlung

Axial drilling and milling head for internal and external cooling

Tête d'alésage et de fraisage axiale pour refroidissement interne et externe

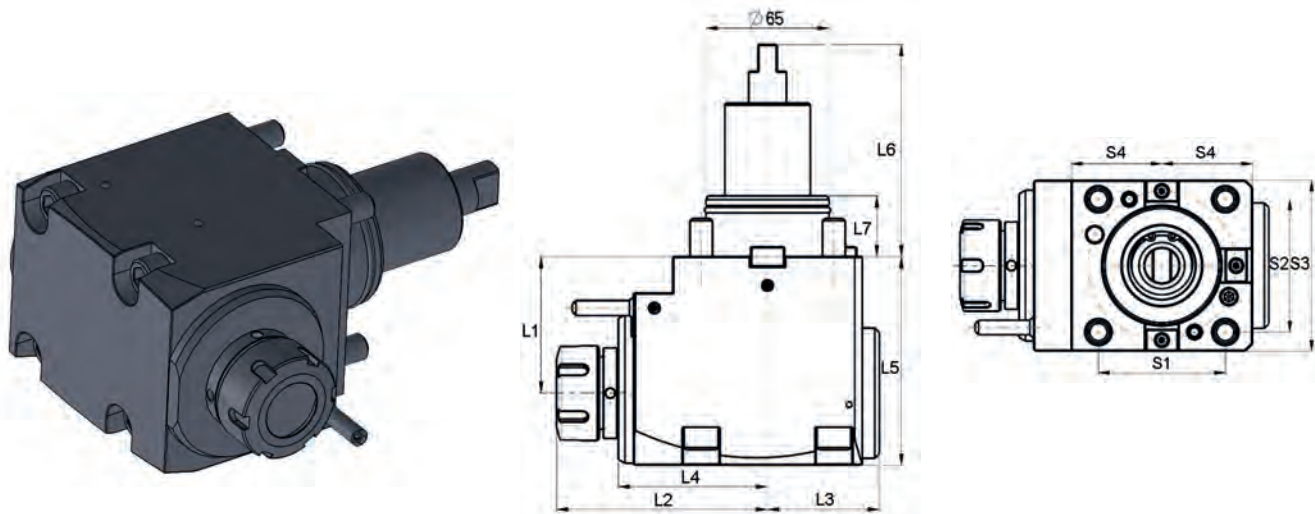

HAAS ST-Line | BMT 65 | IC | EC | ER 32 | 1:1

Bestell-Nr. Order no. Référence	S1	S2	S3	S4	L1	L2	L3	L4	L5	L6	L7	n max. min-1	T max. Nm
AW.221.265.20.756	70	73	94	50	72	111,3	59	78,7	110	112	32	6000	70



DIN 6499 (ISO 15488) System ER

Collet chucks with straight shank with with clamping surface for collets DIN 6499 (ISO 15488) ER-system
Mandrins à pinces à queue cylindrique avec surface de serrage pour pinces DIN 6499 (ISO 15488) ER



Verwendung:
Zur Aufnahme von Werkzeugen mit Zylinderschaft in Spannzangen.
Application:
For mounting straight-shank tools in collets.
Application:
Pour le serrage d'outils avec queue cylindrique dans des pinces de serrage.

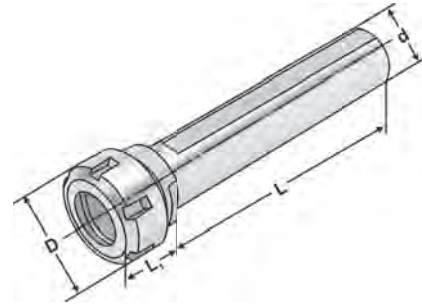

Bestell-Nr. Order no. Référence	d _{H6}	Spannbereich Capacity Capacité	L	L ₁	D
120.02.04.20.1	40	2 - 20 (ER 32)	120	41	50

Hakenschlüssel mit Zapfen

Hook wrench with pin 45-50 | ER32 | 2-20 |
Clé à ergot rond 45-50 | ER32 | 2-20 |



Bestell-Nr. Order no. Référence	Spannbereich Capacity Capacité
AW.SE4550	45 - 50 (ER 32)

Spannschlüssel für Spannmuttern System ER

Wrenches for clamping nuts ER-system
Clés de serrage pour écrous de serrage système ER



Bestell-Nr. Order no. Référence	Spannbereich Capacity Capacité
02.20	2 - 20 (ER 32)



Anfrageformular für angetriebene Werkzeuge

Request Form for Driven Tools

Formulaire de demande pour outils entraînés

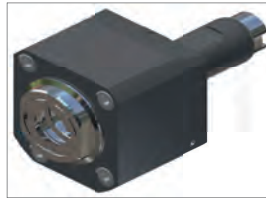

Maschinen-Grunddaten:

Machine basic data / Données de base machine

Maschinen Hersteller / Typ: _____

Machinery manufacturer / Fabricant-type de la machine

Drehzahl Revolverspindel (n): _____

Number of revolutions turret spindle / Nombres révolutions broche de tourelle

Revolverhersteller / Typ: _____

Turret manufacturer / Fabricant-type de tourelle

Drehmoment Revolverspindel (T): _____

Torque turret spindle / Torque broche de tourelle

Revolvertyp:

Turret typ / Type de tourelle

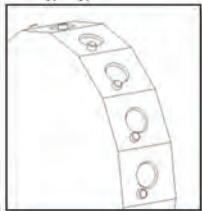

Sternrevolver
Star turret / Tourelle étoile

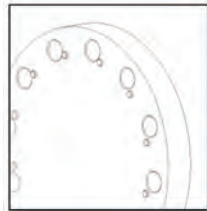

Scheibenrevolver
Disk turret / Tourelle disque

Revolveraufnahme:

Turret dimensions / Dimension tourelle

VDI: z.B 25;30;40...
e.g. / p. ex. 25;30;40...

BMT: z.B 45;55;65...
e.g. / p. ex. 45;55;65...

CDI: z.B 68;80...
e.g. / p. ex. 68;80...

Sonstiges: _____
Other / Autre

Antriebstyp:

Drive type / Type d'entraînement

z.B: DIN1809; DIN5480; DIN 5482
e.g.: DIN 1809; DIN 5480; DIN 5482
p. ex. DIN 1809; DIN 5480; DIN 5482

Zeichnung im Anhang:
Drawing in the appendix / Dessin en annexe

Werkzeugtyp:

Tool type / Type d'outil

Axial: Axial/Axial

Desaxial: Desaxial / Desaxial

Radial: Radial / Radial

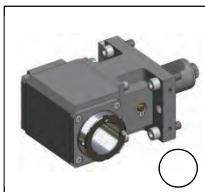
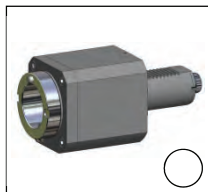

Spindelrichtung:

Spindle direction / Direction de broche

Rechtes Werkzeug:

Right tool / Outil de droite

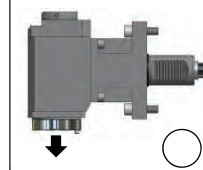

Linkes Werkzeug:

Left tool / Outil de gauche

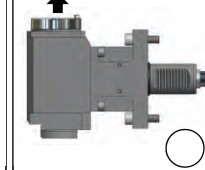

Doppelverzahnung:

Double toothing / Double denture

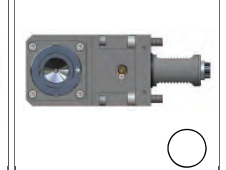

Radial: zurückgesetzt
Radially reset / Radial réinitialisé



Schwenkopf:
Swivel head / Tête pivotante

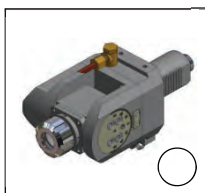

Radial: zweifach
Radial double / Radial doublement

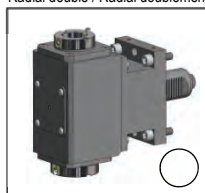

Werkzeugaufnahme:

Tool holder / Porte-outil

Spannzange:
Collet / Pince serrage

HW:
HW / HW

Capto:
Capto / Capto

Fräsdorn:
Abor / Arbre de

Größe
Size / Taille

HSK:
HSK / HSK

Hydrodehn:
Hydrodehn / Expans. Hydr.

Weldon:
Weldon / Weldon

Sonstiges: _____
Other / Autre

Größe
Size / Taille

Übersetzungsverhältnis:

Transmission ratio / Rapport de transmission

n1 : n2 = :

Kühlmittelzufuhr:

Coolant supply / Alimentation de réfrigérant

Nein
No / Non

Extern
External / Externe

Intern
Internal / Interne

Druck Bar
Pressure / Pression

Angaben zur Bearbeitung:

Notes for the application / Informations pour le traitement

Bohren:
Drill / Percage

Werkzeug-Ø:
Tool Ø / Ø outil

Fräsen:
Mill / Fraisage

Werkzeug-Ø:
Tool Ø / Ø outil

schlichten
finishing / finition

schruppen
roughing / ébauche

Gewindeschneiden:
Threading / Taraudage

Werkzeug-Ø:
Tool Ø / Ø outil

Maße Axial u. Desaxiale Werkzeuge

Dimensions axial and desaxial tools / Dimensions outils axiaux et desaxiaux

Werkzeug Daten:

Tool data / Données de l'outil

Drehzahl n max.: _____ 1/min

RPM / Vitesse de rot

Drehmoment T max.: _____ Nm

Torque / Torque

Notizen:

Notes / Notes

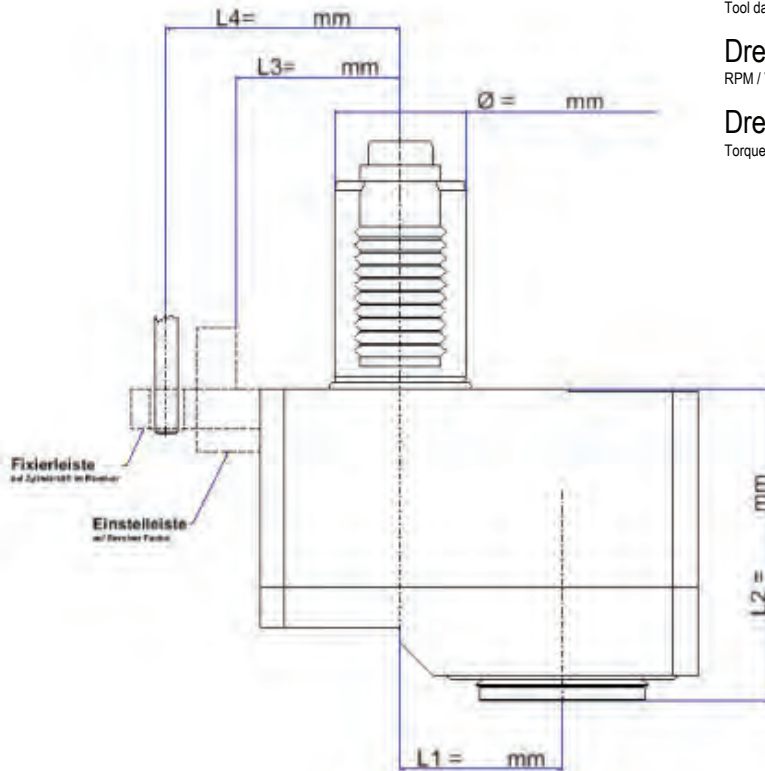

Maße Radiale Werkzeuge

Dimensions radial tools / Dimensions outils radiaux

Werkzeug Daten:

Tool data / Données l'outil

Drehzahl n max.: _____ 1/min

RPM / Vitesse de rot

Drehmoment T max.: _____ Nm

Torque / Torque

Notizen:

Notes / Notes

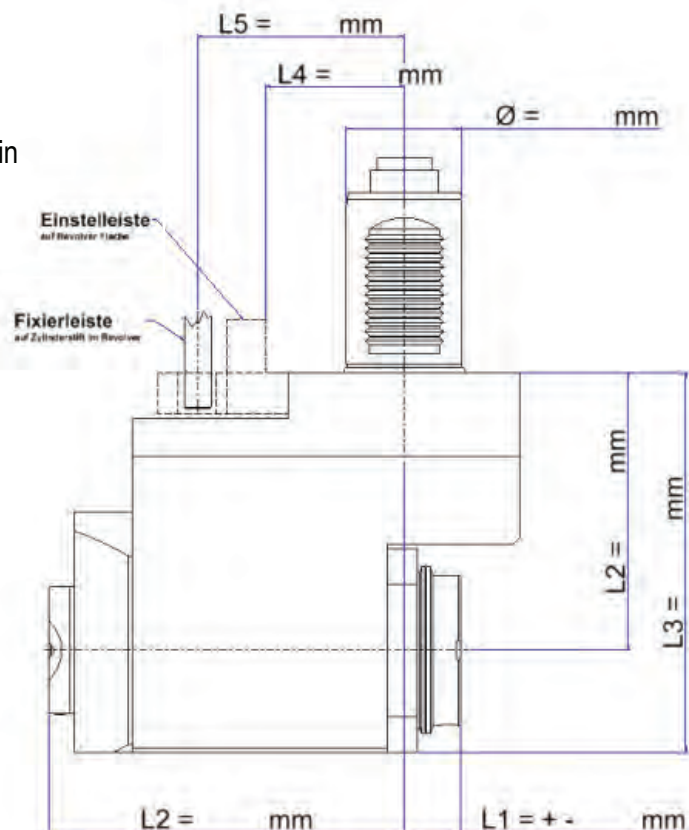

*WERKZEUGAUFNAHMEN
MK DIN 228-1 A / DIN 228-1 B*

*TOOLHOLDERS
MT DIN 228-1 A / DIN 228-1 B*

*PORTE-OUTILS
CM DIN 228-1 A / DIN 228-1 B*

DIN 228

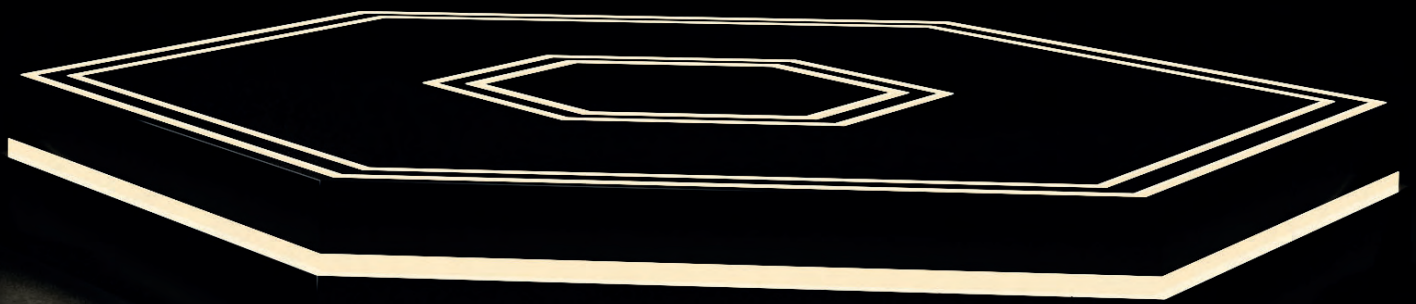

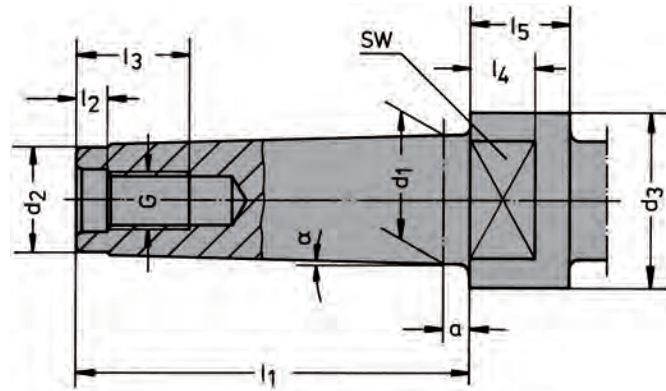
Toolholders MT DIN 228-1 A
Porte-outils CM DIN 228-1 A

MK	α	G	a	d_1	d_2 max.	d_3	SW d^9	l_1	l_2	l_3	l_4	l_5
1	1°25'43"	M6	3,5	12,065	9	-	-	-	4	16	-	-
2	1°25'50"	M10	5	17,780	14	-	-	-	5	24	-	-
3	1°26'16"	M12	5	23,825	19	36	24	86	5,5	24	12	18
4	1°29'15"	M16	6,5	31,267	25	43	32	109	8,2	32	15	23
5	1°30'26"	M20	6,5	44,399	35,7	60	45	136	10	40	18	28
6	1°29'36"	M24	8	63,348	51	84	65	190	11,5	47	25	39

- Werkstoff:** Legierter Einsatzstahl mit einer Zugfestigkeit im Kern von min. 1200 N/mm² Einsatzgehärtet HRC 60 ± 2 (HV 700 ± 50), Härtetiefe 0,8 mm ± 0,2 mm, brüniert und präzisionsgeschliffen.
- Material:** Alloyed case hardened steel, tensile strength in the core of min. 1200 N/mm² Case hardened HRC 60 ± 2 (HV 700 ± 50), hardening depth 0.8 mm ± 0.2 mm, black-finished and precisely grinded.
- Matière:** Châssis d'allié en acier de cémentation. Résistance à la traction dans le noyau de min 1200 N/mm² Trempé à HRC 60 ± 2 (HV 700 ± 50), profondeur de trempé 0,8 mm ± 0,2 mm, bruni et rectifié précisément.



Index
Sommaire

8.05	8.06	8.07	8.08
8.09	8.10	8.11	8.12



DIN 6499 (ISO 15488) System ER

Collet chucks for collets DIN 6499 (ISO 15488) ER-system
Mandrins à pinces pour pinces DIN 6499 (ISO 15488) système ER



Verwendung:
Zur Aufnahme von Werkzeugen mit Zylinderschaft in Spannzangen.
Application:
For mounting straight-shank tools in collets.
Application:
Pour le serrage d'outils avec queue cylindrique dans des pinces de serrage.

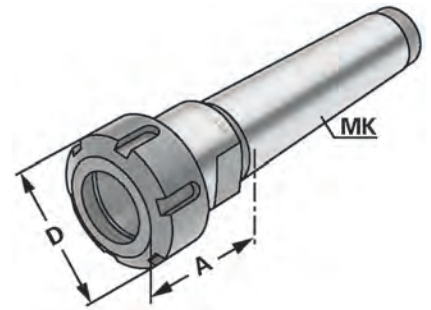

DIN 228-1 A $\nabla \leq 0,008$



Bestell-Nr. Order no. Référence	MK MT CM	Spannbereich Capacity Capacité	A	D
108.02.01 *	MK 2	1 – 10 (ER 16)	45	32
108.02.011	MK 2	2 – 16 (ER 25)	50	42
108.02.012	MK 2	2 – 20 (ER 32)	70	50
108.02.02	MK 3	2 – 16 (ER 25)	56	42
108.02.03	MK 3	2 – 20 (ER 32)	70	50
108.02.04	MK 4	2 – 16 (ER 25)	63	42
108.02.05	MK 4	2 – 20 (ER 32)	65	50
108.02.06	MK 5	3 – 26 (ER 40)	86	63

8

Lieferumfang: Mit gewuchteter Spannmutter
Delivery: With balanced clamping nut
Livraison: Avec écrou de serrage équilibré
* Mit Sechskantmutter
* With hexagonal nut
* Avec écrou hexagonal



Combi shell mill holders DIN 6358
 Porte-fraises à double usage DIN 6358



Verwendung:
 Zur Aufnahme von Walzen-, Walzenstirnfräsern oder Messerköpfen mit Längs- oder Quernut.

Application:
 For mounting milling cutters with transverse or longitudinal groove.

Application:
 Pour le serrage de fraises à rainure transversale ou à rainure longitudinale.

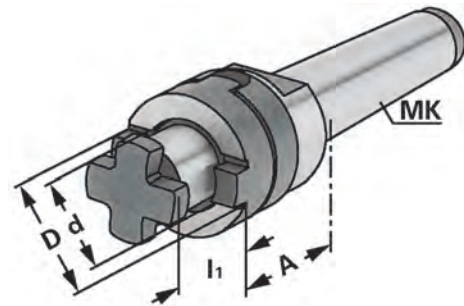

DIN 228-1 A $\nabla \leq 0,008$

Bestell-Nr. Order no. Référence	MK MT CM	d	A	l ₁	D
108.10.20	MK 2	16	43	17	32
108.10.21	MK 2	22	43	19	40
108.10.30	MK 3	16	48	17	32
108.10.31	MK 3	22	48	19	40
108.10.32	MK 3	27	48	21	48
108.10.33	MK 3	32	48	24	58
108.10.40	MK 4	16	55	17	32
108.10.41	MK 4	22	55	19	40
108.10.42	MK 4	27	55	21	48
108.10.43	MK 4	32	55	24	58
108.10.50	MK 5	22	75	19	40
108.10.51	MK 5	27	75	21	48
108.10.52	MK 5	32	75	24	58
108.10.53	MK 5	40	75	27	70

Lieferumfang: Mit Fräseranzugsschraube, Mitnehmerring und Passfeder
Delivery: With tightening bolt, driving ring and feather key
Livraison: Avec vis de blocage, bague d'entraînement et clavette

8





auf Druck und Zug

Quick change tapping chucks with length compensation on compression and expansion

Mandrins de taraudage à changement rapide avec compensation longitudinale à la compression et traction



Verwendung:

Zur Aufnahme von Schnellwechsel-Einsätzen für Gewindebohrer.

Application:

For the chucking of Quick change taps for threading taps.

Application:

Pour le serrage des inserts de changement rapide pour tarauds.

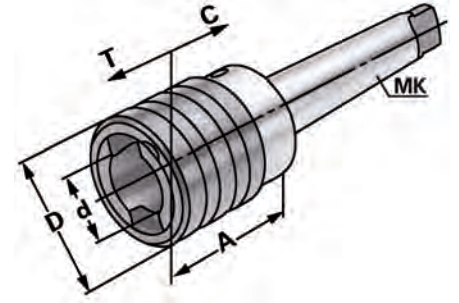

DIN 228-1 B

14.04

Bestell-Nr. Order no. Référence	MK MT CM	Spannbereich Capacity Capacité	Größe Size Taille	A	D	d	T	C
107.16.212	MK 2	M3 – M14	1	46	36	19	7	7
107.16.312	MK 3	M3 – M14	1	46	36	19	7	7
107.16.320	MK 3	M5 – M22	2	70	53	31	12	12
107.16.412	MK 4	M3 – M14	1	46	36	19	7	7
107.16.420	MK 4	M5 – M22	2	71	53	31	12	12
107.16.436	MK 4	M14 – M36	3	128	78	48	17,5	17,5





Reduction sleeves for tools with Morse taper shanks DIN 2185
 Douille de réductions pour outils avec cône Morse DIN 2185



Verwendung:
 Zur Aufnahme von Werkzeugen mit Morsekegelschaft
Application:
 For mounting tools with Morse taper shanks
Application:
 Pour le serrage d'outils avec cône Morse

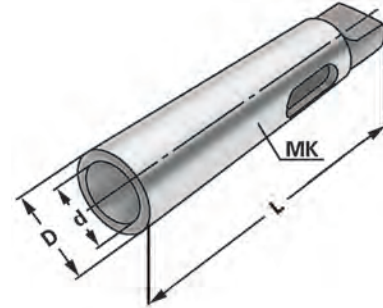

DIN 228-1 B $\nabla \leq 0,010$

Bestell-Nr. Order no. Référence	D	d	L
107.07.21	MK 2	MK 1	92
107.07.32	MK 3	MK 2	98
107.07.42	MK 4	MK 2	124
107.07.43	MK 4	MK 3	132
107.07.53	MK 5	MK 3	156
107.07.54	MK 5	MK 4	171
107.07.64	MK 6	MK 4	218
107.07.65	MK 6	MK 5	218

Ausführung: Ganz gehärtet, innen und außen geschliffen
Version: *Entirely hardened, grinded on the inside and outside*
Version: Entièrement trempé, rectifié à l'intérieur et à l'extérieur





Drill chuck adaptors DIN 238
Arbres pour mandrins de perçage DIN 238



Verwendung:
Zur Aufnahme von Bohrfuttern auf Bohrmaschinen, Drehmaschinen usw.

Application:
For mounting drill chucks on drilling machines, turning lathes etc.

Application:
Pour le serrage de mandrins de perçage sur des perceuses, tournettes etc.

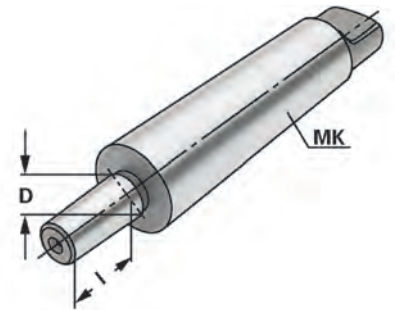

DIN 228-1 B

$\nabla \leq 0,008$

Bestell-Nr. Order no. Référence	MK MT CM	D	l
107.14.12.02	MK 2	B12	12,06
107.14.12.03	MK 3	B12	12,06
107.14.12.04	MK 4	B12	12,06
107.14.02	MK 2	B16	29
107.14.03	MK 3	B16	29
107.14.04	MK 4	B16	29

Ausführung: Ganz gehärtet und geschliffen
Version: Entirely hardened and grinded
Version: Entièrement trempé et rectifié



10.72

CNC-Drill chucks for clockwise and counter clockwise rotation
Mandrins de perçage CNC pour rotation gauche-droite



Verwendung:
Zur Aufnahme von Werkzeugen mit Zylinderschaft.

Application:
For mounting tools with straight shanks.

Application:
Pour le serrage d'outils avec queue cylindrique.

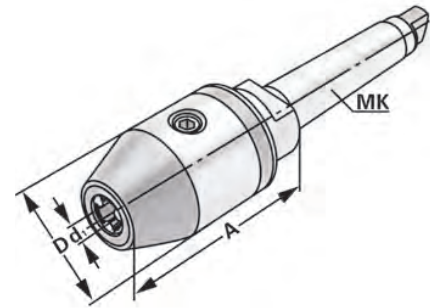

DIN 228-1 B

 $\nearrow \leq 0,030$

14.04

Bestell-Nr. Order no. Référence	MK MT CM	Spannbereich Capacity Capacité	A	D
107.15.313	MK 3	1,0 – 13	98	50
107.15.316	MK 3	2,5 – 16	103	50
107.15.413	MK 4	1,0 – 13	100	50
107.15.416	MK 4	2,5 – 16	105	50

Hinweis: Hohe Präzision und Rundlaufgenauigkeit von $\leq 0,03$ mm. Sichere Spannung des Werkzeuges durch mechanische Spannkraftverstärkung. Kein selbständiges Lösen der Spannung während der Bearbeitung bei Links- oder Rechtslauf, sowie bei Spindelstop. Spannen und Lösen mit Sechskantschlüssel.

Note: *High precision and accurate concentricity of ≤ 0.03 mm. Secure gripping of the tool through mechanical amplification of the clamping force. No automatic slackening of the clamping force while machining with either clockwise or counter clockwise rotation or on spindle stop. Clamping and releasing effected by means of an Allen wrench.*

Observation: Précision élevée et exactitude de circularité de $\leq 0,03$ mm. Serrage sûr de l'outil grâce à l'amplification de la force de serrage. Pas de desserrage intempestif en cours d'usinage lors de la rotation la gauche ou la droite, de même qu'en cas d'arrêt de la broche. Serrage et desserrage en utilisant un clé sur à fourche.

Lieferumfang: Mit Spannschlüssel
Delivery: *With wrench*
Livraison: Avec clé de serrage





Drift tangs to screw in
Tenons à visser



Verwendung:
Zum Spannen und Austreiben von Werkzeug-
kegeln DIN 228-1 A in Werkzeugaufnahmen
DIN 228-1 B.

Application:
*For mounting and drifting taper shanks
DIN 228-1 A in toolholders DIN 228-1 B.*

Application:
Pour le serrage et l'enlèvement de queues
DIN 228-1 A dans porte-outils DIN 228-1 B.

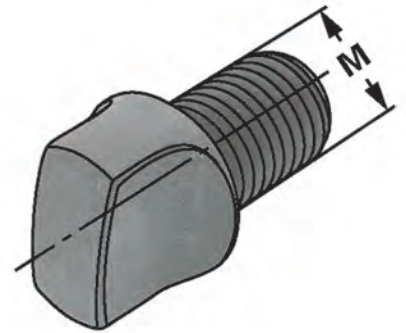

Bestell-Nr. Order no. Référence	MK MT CM	M
107.20.06	MK 1	M6
107.20.10	MK 2	M10
107.20.12	MK 3	M12
107.20.16	MK 4	M16
107.20.20	MK 5	M20



Drill drifts DIN 317 for cones DIN 228 B
 Chasse-cônes DIN 317 pour cônes DIN 228 B



Verwendung:
 Zum Austreiben von Werkzeugen mit
 Werkzeugkegeln DIN 228-1 B.

Application:
 For drifting of tools with taper shanks
 DIN 228-1 B.

Application:
 Pour l'enlèvement d'outils avec queues
 DIN 228-1 B.

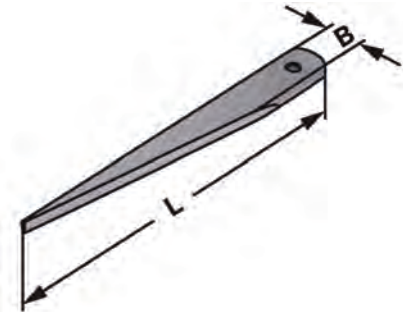

Bestell-Nr. Order no. Référence	MK MT CM	L	B
107.03.01	MK 1+2	140	20
107.03.03	MK 3	190	25
107.03.04	MK 4	225	30

SPANNZANGEN
COLLETS
PINCES

SPANNZANGEN

COLLETS

PINCES

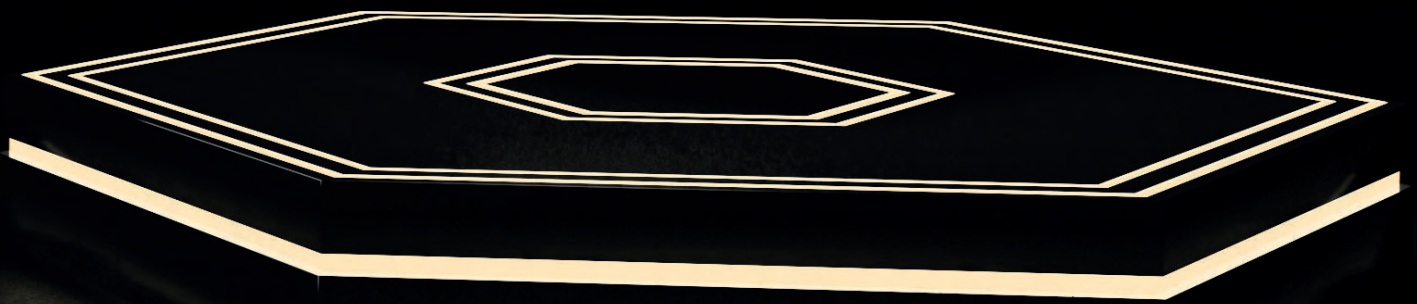
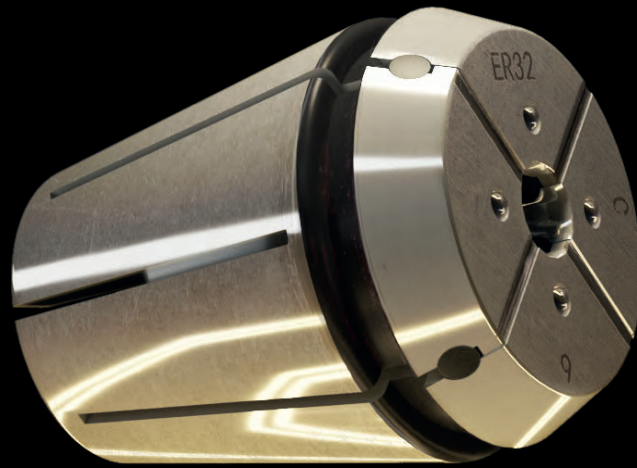



9.05 9.06	9.07 9.08	9.09 9.10	9.11
			
415E 415EP	462E 462EP	467E 467EP	4004EP
9.12 9.13	9.14	9.15 9.16	9.17
			
4008E 4008EP	4008ESP	426E 426EP	426EA
9.18	9.19	9.20	9.21
			
426EH	426EC	426ECC	426ESP
9.22 9.23 9.24	9.25 9.26	9.27	9.28
			
426G 426GC 426GA	428E 428EP	428EA	428EH
9.29	9.30	9.31	9.32 9.33 9.34
			
428EC	428ECC	428ESP	428G 428GC 428GA
9.35 9.36	9.37	9.38	9.39
			
430E 430EP	430EA	430EH	430EC

Index
Sommaire

9.40	9.41	9.42 9.43 9.44	9.45 9.46
430ECC	430ESP	430G 430GC 430 GA	470E 470EP
9.47	9.48	9.49	9.50
470EA	470EH	470EC	470ECC
9.51	9.52 9.53 9.54	9.55 9.56	9.57
470ESP	470G 470GC 470GA	472E 472EP	472EA
9.58	9.59	9.60	9.61 9.62 9.63
472EH	472EC	472ECC	472G 472GC 472GA
9.65	9.65	9.75	9.76
9.77	9.81	9.83	
KPS	HKS	Hydro	



Spannzangen ISO 10897-B (DIN 6388 B) System OZ

Collets ISO 10897-B (DIN 6388 B) OZ-system
Pincettes de serrage ISO 10897-B (DIN 6388 B) système OZ



Verwendung:
Zur Aufnahme von Werkzeugen mit Zylinderschaft in Spannfutter DIN 6391. Für höchste radiale und axiale Belastungen.

Application:
For mounting straight-shank tools in collet chucks DIN 6391. For highest axial and radial loading.

Application:
Pour le serrage d'outils avec queue cylindrique dans mandrins à pinces DIN 6391. Pour une charge radiale et axiale maximale.

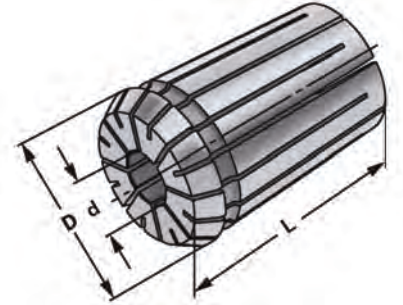

ISO 10897 B
DIN 6388 B

OZ

$\nabla \leq 0,015$



Bestell-Nr. Order no. Référence	Größe Size Taille	d	D	L
415E-02	OZ 16	2 - 1,5	25,5	40
415E-03	OZ 16	3 - 2,5	25,5	40
415E-04	OZ 16	4 - 3,5	25,5	40
415E-05	OZ 16	5 - 4,5	25,5	40
415E-06	OZ 16	6 - 5,5	25,5	40
415E-07	OZ 16	7 - 6,5	25,5	40
415E-08	OZ 16	8 - 7,5	25,5	40
415E-09	OZ 16	9 - 8,5	25,5	40
415E-10	OZ 16	10 - 9,5	25,5	40
415E-11	OZ 16	11 - 10,5	25,5	40
415E-12	OZ 16	12 - 11,5	25,5	40
415E-13	OZ 16	13 - 12,5	25,5	40
415E-14	OZ 16	14 - 13,5	25,5	40
415E-15	OZ 16	15 - 14,5	25,5	40
415E-16	OZ 16	16 - 15,5	25,5	40



Precision collets ISO 10897-B (DIN 6388 B) OZ-system

Pinces de serrage de précision ISO 10897-B (DIN 6388 B) système OZ



Verwendung:

Zur Aufnahme von Werkzeugen mit Zylinder-schaft in Spannfutter DIN 6391. Für Anwen-dungen im HSC-Bereich und für hochpräzise Bearbeitungsergebnisse.

Application:

For mounting straight-shank tools in collet chucks DIN 6391. To use for high speed cutting and high precision milling.

Application:

Pour le serrage d'outils avec queue cylin-drique dans mandrins à pinces DIN 6391. Pour l'usage dans le coupage à grande vitesse et dans l'usinage à grande précision.

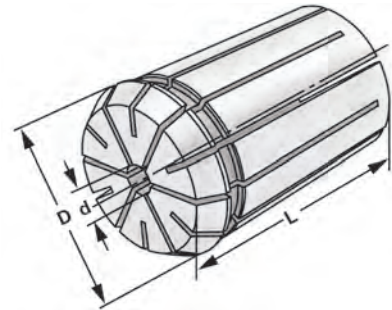

ISO 10897 B
DIN 6388 B

OZ

$\lambda \leq 0,005$

14.04

Bestell-Nr. Order no. Référence	Größe Size Taille	d	D	L
415EP-02	OZ 16	2 - 1,5	25,5	40
415EP-03	OZ 16	3 - 2,5	25,5	40
415EP-04	OZ 16	4 - 3,5	25,5	40
415EP-05	OZ 16	5 - 4,5	25,5	40
415EP-06	OZ 16	6 - 5,5	25,5	40
415EP-07	OZ 16	7 - 6,5	25,5	40
415EP-08	OZ 16	8 - 7,5	25,5	40
415EP-09	OZ 16	9 - 8,5	25,5	40
415EP-10	OZ 16	10 - 9,5	25,5	40
415EP-11	OZ 16	11 - 10,5	25,5	40
415EP-12	OZ 16	12 - 11,5	25,5	40
415EP-13	OZ 16	13 - 12,5	25,5	40
415EP-14	OZ 16	14 - 13,5	25,5	40
415EP-15	OZ 16	15 - 14,5	25,5	40
415EP-16	OZ 16	16 - 15,5	25,5	40



9.66

9.66

10.11



Spannzangen ISO 10897-B (DIN 6388 B) System OZ

Collets ISO 10897-B (DIN 6388 B) OZ-system

Pinces de serrage ISO 10897-B (DIN 6388 B) système OZ



Verwendung:

Zur Aufnahme von Werkzeugen mit Zylinderschaft in Spannfutter DIN 6391. Für höchste radiale und axiale Belastungen.

Application:

For mounting straight-shank tools in collet chucks DIN 6391. For highest axial and radial loading.

Application:

Pour le serrage d'outils avec queue cylindrique dans mandrins à pinces DIN 6391. Pour une charge radiale et axiale maximale.

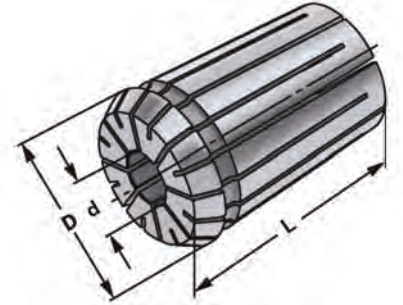

ISO 10897 B
DIN 6388 B

OZ

$\nabla \leq 0,015$



Bestell-Nr. Order no. Référence	Größe Size Taille	d	D	L
462E-02	OZ 25	2 - 1,5	35,05	52
462E-03	OZ 25	3 - 2,5	35,05	52
462E-04	OZ 25	4 - 3,5	35,05	52
462E-05	OZ 25	5 - 4,5	35,05	52
462E-06	OZ 25	6 - 5,5	35,05	52
462E-07	OZ 25	7 - 6,5	35,05	52
462E-08	OZ 25	8 - 7,5	35,05	52
462E-09	OZ 25	9 - 8,5	35,05	52
462E-10	OZ 25	10 - 9,5	35,05	52
462E-11	OZ 25	11 - 10,5	35,05	52
462E-12	OZ 25	12 - 11,5	35,05	52
462E-13	OZ 25	13 - 12,5	35,05	52
462E-14	OZ 25	14 - 13,5	35,05	52
462E-15	OZ 25	15 - 14,5	35,05	52
462E-16	OZ 25	16 - 15,5	35,05	52
462E-17	OZ 25	17 - 16,5	35,05	52
462E-18	OZ 25	18 - 17,5	35,05	52
462E-19	OZ 25	19 - 18,5	35,05	52
462E-20	OZ 25	20 - 19,5	35,05	52
462E-21	OZ 25	21 - 20,5	35,05	52
462E-22	OZ 25	22 - 21,5	35,05	52
462E-23	OZ 25	23 - 22,5	35,05	52
462E-24	OZ 25	24 - 23,5	35,05	52
462E-25	OZ 25	25 - 24,5	35,05	52



9.65



9.65



10.11

Precision collets ISO 10897-B (DIN 6388 B) OZ-system

Pincettes de serrage de précision ISO 10897-B (DIN 6388 B) système OZ



Verwendung:

Zur Aufnahme von Werkzeugen mit Zylinder-schaft in Spannfutter DIN 6391. Für Anwen-dungen im HSC-Bereich und für hochpräzise Bearbeitungsergebnisse.

Application:

For mounting straight-shank tools in collet chucks DIN 6391. To use for high speed cutting and high precision milling.

Application:

Pour le serrage d'outils avec queue cylin-drique dans mandrins à pincettes DIN 6391. Pour l'usage dans le coupage à grande vitesse et dans l'usinage à grande précision.

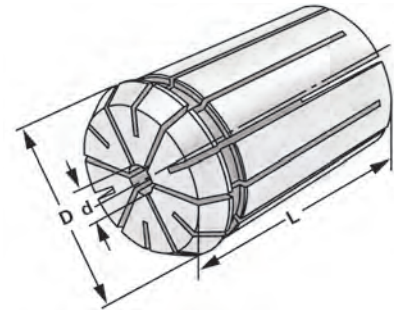

ISO 10897 B
DIN 6388 B

OZ

$\lambda \leq 0,005$

14.04

Bestell-Nr. Order no. Référence	Größe Size Taille	d	D	L
462EP-02	OZ 25	2 - 1,5	35,05	52
462EP-03	OZ 25	3 - 2,5	35,05	52
462EP-04	OZ 25	4 - 3,5	35,05	52
462EP-05	OZ 25	5 - 4,5	35,05	52
462EP-06	OZ 25	6 - 5,5	35,05	52
462EP-07	OZ 25	7 - 6,5	35,05	52
462EP-08	OZ 25	8 - 7,5	35,05	52
462EP-09	OZ 25	9 - 8,5	35,05	52
462EP-10	OZ 25	10 - 9,5	35,05	52
462EP-11	OZ 25	11 - 10,5	35,05	52
462EP-12	OZ 25	12 - 11,5	35,05	52
462EP-13	OZ 25	13 - 12,5	35,05	52
462EP-14	OZ 25	14 - 13,5	35,05	52
462EP-15	OZ 25	15 - 14,5	35,05	52
462EP-16	OZ 25	16 - 15,5	35,05	52
462EP-17	OZ 25	17 - 16,5	35,05	52
462EP-18	OZ 25	18 - 17,5	35,05	52
462EP-19	OZ 25	19 - 18,5	35,05	52
462EP-20	OZ 25	20 - 19,5	35,05	52
462EP-21	OZ 25	21 - 20,5	35,05	52
462EP-22	OZ 25	22 - 21,5	35,05	52
462EP-23	OZ 25	23 - 22,5	35,05	52
462EP-24	OZ 25	24 - 23,5	35,05	52
462EP-25	OZ 25	25 - 24,5	35,05	52



9.66

9.66

10.11



Spannzangen ISO 10897-B (DIN 6388 B) System OZ

Collets ISO 10897-B (DIN 6388 B) OZ-system

Pincès de serrage ISO 10897-B (DIN 6388 B) système OZ



Verwendung:

Zur Aufnahme von Werkzeugen mit Zylinderschaft in Spannfutter DIN 6391. Für höchste radiale und axiale Belastungen.

Application:

For mounting straight-shank tools in collet chucks DIN 6391. For highest axial and radial loading.

Application:

Pour le serrage d'outils avec queue cylindrique dans mandrins à pincès DIN 6391. Pour une charge radiale et axiale maximale.

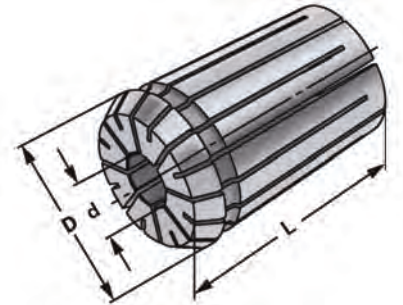

ISO 10897 B
DIN 6388 B

OZ

$\nabla \leq 0,015$



Bestell-Nr. Order no. Référence	Größe Size Taille	d	D	L
467E-03	OZ 32	3 - 2,5	43,7	60
467E-04	OZ 32	4 - 3,5	43,7	60
467E-05	OZ 32	5 - 4,5	43,7	60
467E-06	OZ 32	6 - 5,5	43,7	60
467E-07	OZ 32	7 - 6,5	43,7	60
467E-08	OZ 32	8 - 7,5	43,7	60
467E-09	OZ 32	9 - 8,5	43,7	60
467E-10	OZ 32	10 - 9,5	43,7	60
467E-11	OZ 32	11 - 10,5	43,7	60
467E-12	OZ 32	12 - 11,5	43,7	60
467E-13	OZ 32	13 - 12,5	43,7	60
467E-14	OZ 32	14 - 13,5	43,7	60
467E-15	OZ 32	15 - 14,5	43,7	60
467E-16	OZ 32	16 - 15,5	43,7	60
467E-17	OZ 32	17 - 16,5	43,7	60
467E-18	OZ 32	18 - 17,5	43,7	60
467E-19	OZ 32	19 - 18,5	43,7	60
467E-20	OZ 32	20 - 19,5	43,7	60
467E-21	OZ 32	21 - 20,5	43,7	60
467E-22	OZ 32	22 - 21,5	43,7	60
467E-23	OZ 32	23 - 22,5	43,7	60
467E-24	OZ 32	24 - 23,5	43,7	60
467E-25	OZ 32	25 - 24,5	43,7	60
467E-26	OZ 32	26 - 25,5	43,7	60
467E-27	OZ 32	27 - 26,5	43,7	60
467E-28	OZ 32	28 - 27,5	43,7	60
467E-29	OZ 32	29 - 28,5	43,7	60
467E-30	OZ 32	30 - 29,5	43,7	60
467E-31	OZ 32	31 - 30,5	43,7	60
467E-32	OZ 32	32 - 31,5	43,7	60



9.65



9.65



10.11

Precision collets ISO 10897-B (DIN 6388 B) OZ-system

Pincettes de serrage de précision ISO 10897-B (DIN 6388 B) système OZ



Verwendung:

Zur Aufnahme von Werkzeugen mit Zylinder-schaft in Spannfutter DIN 6391. Für Anwen-dungen im HSC-Bereich und für hochpräzise Bearbeitungsergebnisse.

Application:

For mounting straight-shank tools in collet chucks DIN 6391. To use for high speed cutting and high precision milling.

Application:

Pour le serrage d'outils avec queue cylin-drique dans mandrins à pincettes DIN 6391. Pour l'usage dans le coupage à grande vitesse et dans l'usinage à grande précision.

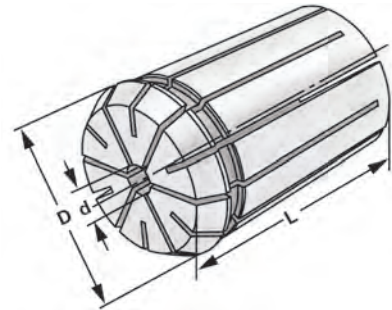

ISO 10897 B
DIN 6388 B

OZ

$\lambda \leq 0,005$

14.04

Bestell-Nr. Order no. Référence	Größe Size Taille	d	D	L
467EP-03	OZ 32	3 - 2,5	43,7	60
467EP-04	OZ 32	4 - 3,5	43,7	60
467EP-05	OZ 32	5 - 4,5	43,7	60
467EP-06	OZ 32	6 - 5,5	43,7	60
467EP-07	OZ 32	7 - 6,5	43,7	60
467EP-08	OZ 32	8 - 7,5	43,7	60
467EP-09	OZ 32	9 - 8,5	43,7	60
467EP-10	OZ 32	10 - 9,5	43,7	60
467EP-11	OZ 32	11 - 10,5	43,7	60
467EP-12	OZ 32	12 - 11,5	43,7	60
467EP-13	OZ 32	13 - 12,5	43,7	60
467EP-14	OZ 32	14 - 13,5	43,7	60
467EP-15	OZ 32	15 - 14,5	43,7	60
467EP-16	OZ 32	16 - 15,5	43,7	60
467EP-17	OZ 32	17 - 16,5	43,7	60
467EP-18	OZ 32	18 - 17,5	43,7	60
467EP-19	OZ 32	19 - 18,5	43,7	60
467EP-20	OZ 32	20 - 19,5	43,7	60
467EP-21	OZ 32	21 - 20,5	43,7	60
467EP-22	OZ 32	22 - 21,5	43,7	60
467EP-23	OZ 32	23 - 22,5	43,7	60
467EP-24	OZ 32	24 - 23,5	43,7	60
467EP-25	OZ 32	25 - 24,5	43,7	60
467EP-26	OZ 32	26 - 25,5	43,7	60
467EP-27	OZ 32	27 - 26,5	43,7	60
467EP-28	OZ 32	28 - 27,5	43,7	60
467EP-29	OZ 32	29 - 28,5	43,7	60
467EP-30	OZ 32	30 - 29,5	43,7	60
467EP-31	OZ 32	31 - 30,5	43,7	60
467EP-32	OZ 32	32 - 31,5	43,7	60



9.66

9.66

10.11



Spannzangen ISO 15488 B (DIN 6499 B) System ER

Collets ISO 15488 B (DIN 6499 B) ER-system

Pincettes de serrage ISO 15488 B (DIN 6499 B) système ER



Verwendung:

Zur Aufnahme von Werkzeugen mit Zylinderschaft in Spannfutter DIN 6499.

Application:

For mounting straight-shank tools in collet chucks DIN 6499.

Application:

Pour le serrage d'outils avec queue cylindrique dans mandrins à pincettes DIN 6499.

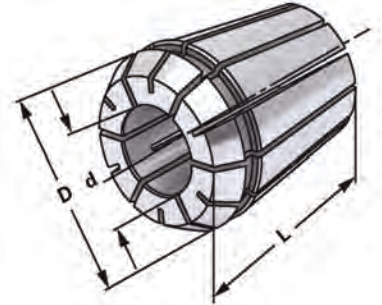

ISO 15488 B
DIN 6499 B

ER

$\nabla \leq 0,005$

14.04

Bestell-Nr. Order no. Référence	Größe Size Taille	d	D	L
4004EP-01	ER 8	1,0 - 0,5	8,5	13,5
4004EP-015	ER 8	1,5 - 1,0	8,5	13,5
4004EP-02	ER 8	2,0 - 1,5	8,5	13,5
4004EP-025	ER 8	2,5 - 2,0	8,5	13,5
4004EP-03	ER 8	3,0 - 2,5	8,5	13,5
4004EP-035	ER 8	3,5 - 3,0	8,5	13,5
4004EP-04	ER 8	4,0 - 3,5	8,5	13,5
4004EP-045	ER 8	4,5 - 4,0	8,5	13,5
4004EP-05	ER 8	5,0 - 4,5	8,5	13,5

Hinweis:

Spannbereich bis -0,5 mm

Note:

Clamping capacity up to -0,5 mm

Observation:

Serrage jusqu'à -0,5 mm



Collets ISO 15488 B (DIN 6499 B) ER-system

Pinces de serrage ISO 15488 B (DIN 6499 B) système ER



Verwendung:
Zur Aufnahme von Werkzeugen mit Zylinderschaft in Spannfutter DIN 6499.

Application:
For mounting straight-shank tools in collet chucks DIN 6499.

Application:
Pour le serrage d'outils avec queue cylindrique dans mandrins à pinces DIN 6499.

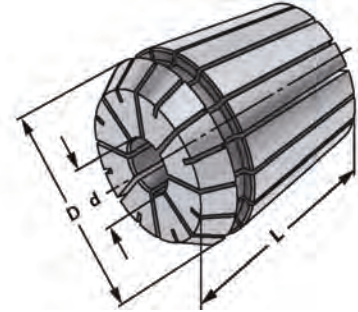

ISO 15488 B
DIN 6499 B

ER

$\nabla \leq 0,015$

14.04

Bestell-Nr. Order no. Référence	Größe Size Taille	d	D	L
4008E-01	ER 11	1,0 - 0,5	11,5	18
4008E-015	ER 11	1,5 - 1,0	11,5	18
4008E-02	ER 11	2,0 - 1,5	11,5	18
4008E-025	ER 11	2,5 - 2,0	11,5	18
4008E-03	ER 11	3,0 - 2,5	11,5	18
4008E-035	ER 11	3,5 - 3,0	11,5	18
4008E-04	ER 11	4,0 - 3,5	11,5	18
4008E-045	ER 11	4,5 - 4,0	11,5	18
4008E-05	ER 11	5,0 - 4,5	11,5	18
4008E-055	ER 11	5,5 - 5,0	11,5	18
4008E-06	ER 11	6,0 - 5,5	11,5	18
4008E-065	ER 11	6,5 - 6,0	11,5	18
4008E-07	ER 11	7,0 - 6,5	11,5	18

Hinweis: Spannbereich bis -0,5 mm
Note: Clamping capacity up to -0,5 mm
Observation: Serrage jusqu'à -0,5 mm





Präzisionsspannzangen ISO 15488 B (DIN 6499 B) System ER

Precision collets ISO 15488 B (DIN 6499 B) ER-system

Pinces de serrage de précision ISO 15488 B (DIN 6499 B) système ER

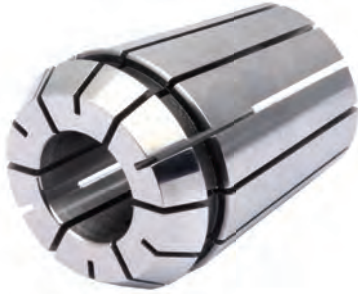

Verwendung:

Zur Aufnahme von Werkzeugen mit Zylinderschaft in Spannfutter DIN 6499. Für Anwendungen im HSC-Bereich und für hochpräzise Bearbeitungsergebnisse.

Application:

For mounting straight-shank tools in collet chucks DIN 6499. To use for high speed cutting and high precision milling.

Application:

Pour le serrage d'outils avec queue cylindrique dans mandrins à pinces DIN 6499. Pour l'usage dans le coupage à grande vitesse et dans l'usinage à grande précision.

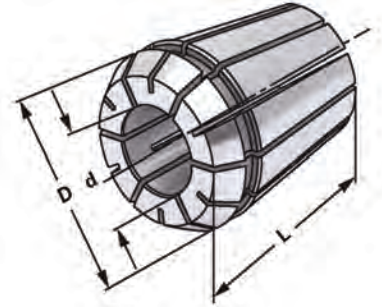

ISO 15488 B
DIN 6499 B

ER

$\nabla \leq 0,005$



Bestell-Nr. Order no. Référence	Größe Size Taille	d	D	L
4008EP-01	ER 11	1,0 - 0,5	11,5	18
4008EP-015	ER 11	1,5 - 1,0	11,5	18
4008EP-02	ER 11	2,0 - 1,5	11,5	18
4008EP-025	ER 11	2,5 - 2,0	11,5	18
4008EP-03	ER 11	3,0 - 2,5	11,5	18
4008EP-035	ER 11	3,5 - 3,0	11,5	18
4008EP-04	ER 11	4,0 - 3,5	11,5	18
4008EP-045	ER 11	4,5 - 4,0	11,5	18
4008EP-05	ER 11	5,0 - 4,5	11,5	18
4008EP-055	ER 11	5,5 - 5,0	11,5	18
4008EP-06	ER 11	6,0 - 5,5	11,5	18
4008EP-065	ER 11	6,5 - 6,0	11,5	18
4008EP-07	ER 11	7,0 - 6,5	11,5	18

Hinweis: Spannbereich bis -0,5 mm
Note: Clamping capacity up to -0,5 mm
Observation: Serrage jusqu'à -0,5 mm

9



Precision collets ISO 15488 B (DIN 6499 B) ER-system - stainless steel

Pinces de serrage de précision ISO 15488 B (DIN 6499 B) système ER - acier inoxydable



Verwendung:

Zur Aufnahme von Werkzeugen mit Zylinderschaft in Spannfutter DIN 6499. Für Anwendungen im HSC-Bereich und für hochpräzise Bearbeitungsergebnisse.

Application:

For mounting straight-shank tools in collet chucks DIN 6499. To use for high speed cutting and high precision milling.

Application:

Pour le serrage d'outils avec queue cylindrique dans mandrins à pinces DIN 6499. Pour l'usage dans le coupage à grande vitesse et dans l'usinage à grande précision.

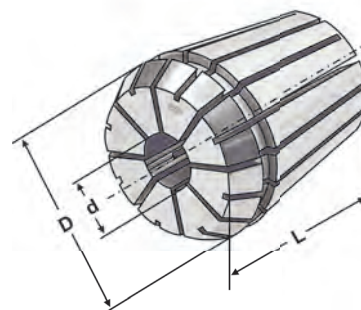

ISO 15488 B
DIN 6499 B

ER

$\lambda \leq 0,005$

14.04

Bestell-Nr. Order no. Référence	Größe Size Taille	d	D	L
4008ESP-03	ER 11	3,0 – 2,5	11,5	18
4008ESP-035	ER 11	3,5 – 3,0	11,5	18
4008ESP-04	ER 11	4,0 – 3,5	11,5	18
4008ESP-045	ER 11	4,5 – 4,0	11,5	18
4008ESP-05	ER 11	5,0 – 4,5	11,5	18
4008ESP-055	ER 11	5,5 – 5,0	11,5	18
4008ESP-06	ER 11	6,0 – 5,5	11,5	18
4008ESP-065	ER 11	6,5 – 6,0	11,5	18
4008ESP-07	ER 11	7,0 – 6,5	11,5	18

Hinweis: Spannbereich bis -0,5 mm
Note: Clamping capacity up to -0,5 mm
Observation: Serrage jusqu'à -0,5 mm

- Rostfrei
- Edelstahl 1.4021 x 20Cr13
- Höhere Wiederholgenauigkeit
- Spannzangenbohrung gehont
- Besonders geeignet für Drahterosion

- Rustproof
- Stainless steel 1.4021 x 20Cr13
- Higher repeat-accuracy
- Honed collet boring
- Especially suitable fore wire EDM

- Inoxydable
- Acier affiné 1.4021 x 20Cr13
- Répétabilité supérieure
- Alésage de pince aiguisé
- Convient particulièrement pour le fil EDM





Spannzangen ISO 15488 B (DIN 6499 B) System ER

Collets ISO 15488 B (DIN 6499 B) ER-system

Pinces de serrage ISO 15488 B (DIN 6499 B) système ER



Verwendung:

Zur Aufnahme von Werkzeugen mit Zylinderschaft in Spannfutter DIN 6499.

Application:

For mounting straight-shank tools in collet chucks DIN 6499.

Application:

Pour le serrage d'outils avec queue cylindrique dans mandrins à pinces DIN 6499.

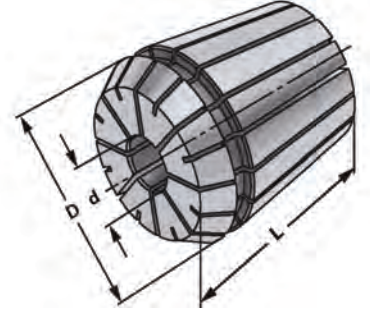

ISO 15488 B
DIN 6499 B

ER

$\nabla \leq 0,015$



Bestell-Nr. Order no. Référence	Größe Size Taille	d	D	L
426E-01	ER 16	1 - 0,5	17	27
426E-02	ER 16	2 - 1,0	17	27
426E-03	ER 16	3 - 2,0	17	27
426E-04	ER 16	4 - 3,0	17	27
426E-05	ER 16	5 - 4,0	17	27
426E-06	ER 16	6 - 5,0	17	27
426E-07	ER 16	7 - 6,0	17	27
426E-08	ER 16	8 - 7,0	17	27
426E-09	ER 16	9 - 8,0	17	27
426E-10	ER 16	10 - 9,0	17	27

Hinweis:

Note:

Observation:

Hohe Flexibilität: Großer Spannbereich bis -1 mm

High flexibility: Large holding capacity up to -1 mm

Grande capacité de serrage jusqu'à -1 mm



Precision collets ISO 15488 B (DIN 6499 B) ER-system

Pinces de serrage de précision ISO 15488 B (DIN 6499 B) système ER

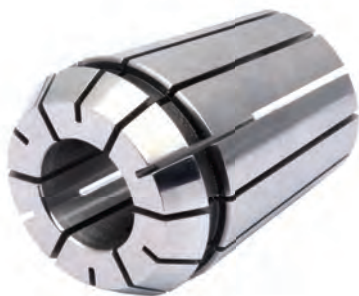

Verwendung:

Zur Aufnahme von Werkzeugen mit Zylinderschaft in Spannfutter DIN 6499. Für Anwendungen im HSC-Bereich und für hochpräzise Bearbeitungsergebnisse.

Application:

For mounting straight-shank tools in collet chucks DIN 6499. To use for high speed cutting and high precision milling.

Application:

Pour le serrage d'outils avec queue cylindrique dans mandrins à pinces DIN 6499. Pour l'usage dans le coupage à grande vitesse et dans l'usinage à grande précision.

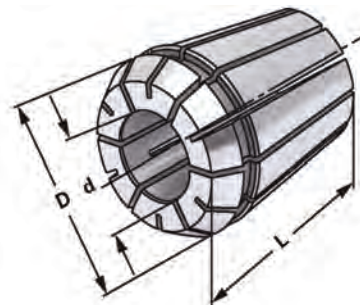

ISO 15488 B
DIN 6499 B

ER

$\nabla \leq 0,005$

14.04

Bestell-Nr. Order no. Référence	Größe Size Taille	d	D	L
426EP-01	ER 16	1 - 0,5	17	27
426EP-02	ER 16	2 - 1,0	17	27
426EP-03	ER 16	3 - 2,0	17	27
426EP-04	ER 16	4 - 3,0	17	27
426EP-05	ER 16	5 - 4,0	17	27
426EP-06	ER 16	6 - 5,0	17	27
426EP-07	ER 16	7 - 6,0	17	27
426EP-08	ER 16	8 - 7,0	17	27
426EP-09	ER 16	9 - 8,0	17	27
426EP-10	ER 16	10 - 9,0	17	27

Hinweis:

Note:

Observation:

Hohe Flexibilität: Großer Spannbereich bis -1 mm

High flexibility: Large holding capacity up to -1 mm

Grande capacité de serrage jusqu'à -1 mm





Spannzangen mit Abdichtung für IK - ISO 15488 B (DIN 6499 B) System ER

Collets sealed for IC - ISO 15488 B (DIN 6499 B) ER-system

Pincettes de serrage avec joint d'étanchéité pour IC - ISO 15488 B (DIN 6499 B) système ER



Verwendung:

Zur Aufnahme von Werkzeugen mit Innenkühlung und Zylinderschaft in Spannfutter DIN 6499

Application:

For mounting straight-shank tools with internal cooling in collet chucks DIN 6499

Application:

Pour le serrage des outils avec le refroidissement interne et avec queue cylindrique dans mandrins à pincettes DIN 6499

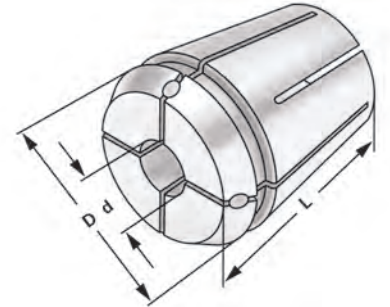

ISO 15488 B
DIN 6499 B

ER

$\nabla \leq 0,015$



Bestell-Nr. Order no. Référence	Größe Size Taille	d	D	L
426EA-03	ER 16	3	17	27
426EA-04	ER 16	4	17	27
426EA-05	ER 16	5	17	27
426EA-06	ER 16	6	17	27
426EA-07	ER 16	7	17	27
426EA-08	ER 16	8	17	27
426EA-09	ER 16	9	17	27
426EA-10	ER 16	10	17	27

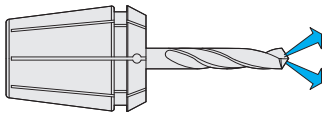

9

Hinweis: Nur das Nennmaß d kann gespannt werden, mit Dichtstopfen für Innenkühlung (einsetzbar bis 21 bar). Um eine optimale Abdichtung zu erreichen, muss das zu spannende Werkzeug auf der ganzen Länge der geschliffenen Bohrung der Spannzange eingespannt werden.

Note: Only nominal size d can be clamped with sealing plug for internal cooling (applicable up to 21 bar). In order to achieve an optimum sealing the tool must be clamped on the complete length of the ground drill of the collet.

Observation: Seulement la dimension nominale d peut être tendu avec des bochons 'étanchéité pour le refroidissement interne (peut être utilisé jusqu'à 21 bar). Afin d'obtenir un étanchéité optimal l'outil doit être serré sur la lon gueur complète de l'alésage rectifié de la pince.



9.67



9.67



10.11

Collets steel sealed for high pressure cooling until 120 bar
 Pinces de serrage, étanche pour arrosage de haute pression 120 bar



Verwendung:
 Zur Aufnahme von Werkzeugen mit Innenkühlung und Zylinderschaft in Spannfutter DIN 6499

Application:
 For mounting straight-shank tools with internal cooling in collet chucks DIN 6499

Application:
 Pour le serrage des outils avec le refroidissement interne et avec queue cylindrique dans mandrins à pinces DIN 6499

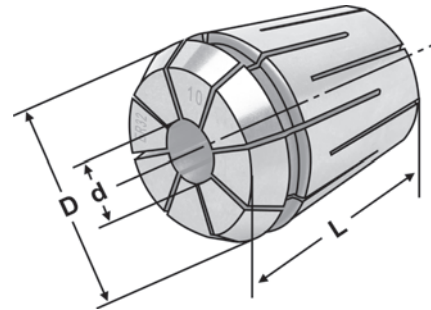

ISO 15488 B
 DIN 6499 B

ER

$\lambda \leq 0,015$



Bestell-Nr. Order no. Référence	Größe Size Taille	d	D	L
426EH-03	ER 16	3	17	27
426EH-04	ER 16	4	17	27
426EH-05	ER 16	5	17	27
426EH-06	ER 16	6	17	27
426EH-07	ER 16	7	17	27
426EH-08	ER 16	8	17	27
426EH-09	ER 16	9	17	27
426EH-10	ER 16	10	17	27

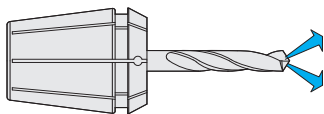

Hinweis: Nur das Nennmaß d kann gespannt werden (einsetzbar bis 120 bar). Um eine optimale Abdichtung zu erreichen, muss das zu spannende Werkzeug auf der ganzen Länge der geschliffenen Bohrung der Spannzange eingespannt werden.

Note: Only nominal size d can be clamped (applicable up to 120 bar). In order to achieve an optimum sealing the tool must be clamped on the complete length of the ground drill of the collet.

Observation: Seulement la dimension nominale d peut être tendu (peut être utilisé jusqu'à 120 bar). Afin d'obtenir un étanchéité optimal l'outil doit être serré sur la longueur complète de l'alésage rectifié de la pince.





Spannzangen mit Kühlkanalbohrungen ISO 15488 B (DIN 6499 B) System ER

Collets with cooling channels ISO 15488 B (DIN 6499 B) ER-system

Pincès de serrage avec canaux d'arrosage ISO 15488 B (DIN 6499 B) système ER



Verwendung:

Zur Aufnahme von Werkzeugen mit Zylinderschaft in Spannfutter DIN 6499.

Application:

For mounting straight-shank tools in collet chucks DIN 6499.

Application:

Pour le serrage d'outils avec queue cylindrique dans mandrins à pincès DIN 6499.

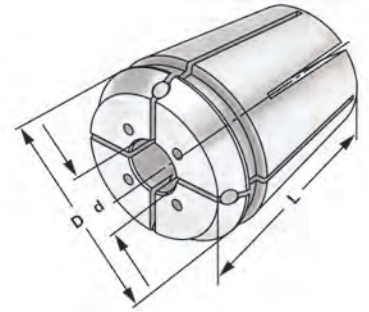

ISO 15488 B
DIN 6499 B

ER

$\nabla \leq 0,015$



Bestell-Nr. Order no. Référence	Größe Size Taille	d	D	L
426EC-03	ER 16	3	17	27
426EC-04	ER 16	4	17	27
426EC-05	ER 16	5	17	27
426EC-06	ER 16	6	17	27
426EC-07	ER 16	7	17	27



9

Hinweis: Nur das Nennmaß d kann gespannt werden, mit Kühlkanälen. Einsetzbar bis 21 bar. Um eine optimale Abdichtung zu erreichen, muss das zu spannende Werkzeug auf der ganzen Länge der geschliffenen Bohrung der Spannzange eingespannt werden.

Note: Only nominal size d can be clamped, with cooling channels. Applicable up to 21 bar. In order to achieve an optimum sealing the tool must be clamped on the complete length of the ground drill of the collet.

Observation: Seulement la dimension nominale d peut être tendu, avec canaux d'arrosage. Peut être utilisé jusqu'à 21 bar. Afin d'obtenir un étanchéité optimal l'outil doit être serré sur la longueur complète de l'alésage rectifié de la pince.



ISO 15488 B (DIN 6499 B) System ER

Collets with cooling channels along the boring ISO 15488 B (DIN 6499 B) ER-system

Pinces de serrage avec canaux d'arrosage le long de l'alésage ISO 15488 B (DIN 6499 B) système ER



Verwendung:
Zur Aufnahme von Werkzeugen mit Zylinderschaft in Spannfutter DIN 6499.

Application:
For mounting straight-shank tools in collet chucks DIN 6499.

Application:
Pour le serrage d'outils avec queue cylindrique dans mandrins à pinces DIN 6499.

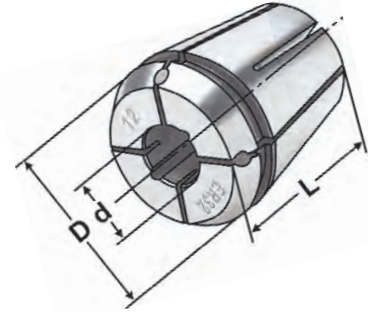

ISO 15488 B
DIN 6499 B

ER

$\nabla \leq 0,015$

14.04

Bestell-Nr. Order no. Référence	Größe Size Taille	d	D	L
426ECC-03	ER 16	3	17	27
426ECC-04	ER 16	4	17	27
426ECC-05	ER 16	5	17	27
426ECC-06	ER 16	6	17	27
426ECC-07	ER 16	7	17	27



Hinweis: Nur das Nennmaß d kann gespannt werden, mit Kühlkanälen entlang der Bohrung. Einsetzbar bis 21 bar. Um eine optimale Abdichtung zu erreichen, muss das zu spannende Werkzeug auf der ganzen Länge der geschliffenen Bohrung der Spannzange eingespannt werden.

Note: Only nominal size d can be clamped, with cooling channels along the boring. Applicable up to 21 bar. In order to achieve an optimum sealing the tool must be clamped on the complete length of the ground drill of the collet.

Observation: Seulement la dimension nominale d peut être tendu, avec canaux d'arrosage le long de l'alésage. Peut être utilisé jusqu'à 21 bar. Afin d'obtenir un étanchéité optimal l'outil doit être serré sur la longueur complète de l'alésage rectifié de la pince.





Präzisionsspannzangen ISO 15488 B (DIN 6499 B) System ER - Edelstahl

Precision collets ISO 15488 B (DIN 6499 B) ER-system - stainless steel

Pinces de serrage de précision ISO 15488 B (DIN 6499 B) système ER - acier inoxydable



Verwendung:

Zur Aufnahme von Werkzeugen mit Zylinderschaft in Spannfutter DIN 6499. Für Anwendungen im HSC-Bereich und für hochpräzise Bearbeitungsergebnisse.

Application:

For mounting straight-shank tools in collet chucks DIN 6499. To use for high speed cutting and high precision milling.

Application:

Pour le serrage d'outils avec queue cylindrique dans mandrins à pinces DIN 6499. Pour l'usage dans le coupage à grande vitesse et dans l'usinage à grande précision.

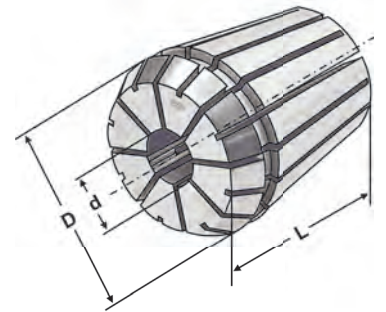

ISO 15488 B
DIN 6499 B

ER

$\lambda \leq 0,005$



Bestell-Nr. Order no. Référence	Größe Size Taille	d	D	L
426ESP-03	ER 16	3 - 2,5	17	27
426ESP-035	ER 16	3,5 - 3,0	17	27
426ESP-04	ER 16	4 - 3,5	17	27
426ESP-045	ER 16	4,5 - 4,0	17	27
426ESP-05	ER 16	5 - 4,5	17	27
426ESP-055	ER 16	5,5 - 5,0	17	27
426ESP-06	ER 16	6 - 5,5	17	27
426ESP-065	ER 16	6,5 - 6,0	17	27
426ESP-07	ER 16	7 - 6,5	17	27
426ESP-075	ER 16	7,5 - 7,0	17	27
426ESP-08	ER 16	8 - 7,5	17	27
426ESP-085	ER 16	8,5 - 8,0	17	27
426ESP-09	ER 16	9 - 8,5	17	27
426ESP-095	ER 16	9,5 - 9,0	17	27
426ESP-10	ER 16	10 - 9,5	17	27

9

Hinweis: Spannbereich bis -0,5 mm
Note: Clamping capacity up to -0,5 mm
Observation: Serrage jusqu'à -0,5 mm

- Rostfrei
- Edelstahl 1.4021 x 20Cr13
- Höhere Wiederholgenauigkeit
- Spannzangenbohrung gehont
- Besonders geeignet für Drahterosion

- Rustproof
- Stainless steel 1.4021 x 20Cr13
- Higher repeat-accuracy
- Honed collet boring
- Especially suitable for wire EDM

- Inoxydable
- Acier affiné 1.4021 x 20Cr13
- Répétabilité supérieure
- Alésage de pince aiguisé
- Convient particulièrement pour le fil EDM



Tap collets - ISO 15488 B (DIN 6499 B) System ER

Pinces de serrage pour tarauds - ISO 15488 B (DIN 6499 B) System ER



Verwendung:
Für Maschinen mit steigungssynchronem Vorschub. Zur verkehrsicheren Spannung von Gewindebohrern.

Application:
For machines with rigid tapping.
For safe clamping of taps.

Application:
Pour machines avec broche synchronisée.
Pour le serrage stable de tarauds.

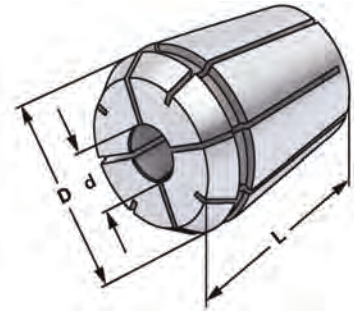

ISO 15488 B
DIN 6499 B

ER

$\nabla \leq 0,015$

14.04

Bestell-Nr. Order no. Référence	Größe Size Taille	Schaft Shaft Queue	Vierkant Square Carré	D	L
426G-3527	ER 16	3,5	2,7	16,8	27,5
426G-43	ER 16	4	3	16,8	27,5
426G-4534	ER 16	4,5	3,4	16,8	27,5
426G-649	ER 16	6	4,9	16,8	27,5
426G-755	ER 16	7	5,5	16,8	27,5
426G-862	ER 16	8	6,2	16,8	27,5





Gewindebohrer Spannzangen mit Kühkanalbohrungen

Tap collets with cooling channels
Pincettes de serrage avec canaux d'arrosage



Verwendung:
Für Maschinen mit steigungssynchronem Vorschub. Zur verdrehensicheren Spannung von Gewindebohrern.

Application:
For machines with rigid tapping. For safe clamping of taps.

Application:
Pour machines avec broche synchronisée. Pour le serrage stable de tarauds.

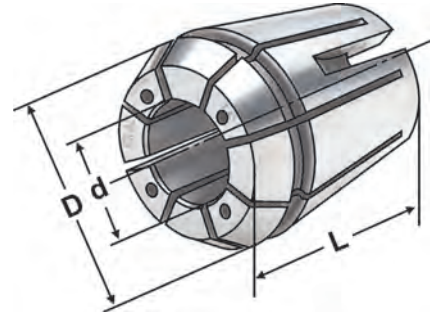

ISO 15488 B
DIN 6499 B

ER

$\nabla \leq 0,015$



Bestell-Nr. Order no. Référence	Größe Size Taille	Schaft Shaft Queue	Vierkant Square Carré	D	L
426GC-3527	ER 16	3,5	2,7	16,8	27,5
426GC-43	ER 16	4	3	16,8	27,5
426GC-4534	ER 16	4,5	3,4	16,8	27,5
426GC-649	ER 16	6	4,9	16,8	27,5
426GC-755	ER 16	7	5,5	16,8	27,5
426GC-862	ER 16	8	6,2	16,8	27,5



9.73



9.73



10.11

Tap collets with seals
Pincés de serrage pour tarauds



Verwendung:
Für Maschinen mit steigungssynchronem Vorschub. Zur verdrehsicheren Spannung von Gewindebohrern.

Application:
For machines with rigid tapping.
For safe clamping of taps.

Application:
Pour machines avec broche synchronisée.
Pour le serrage stable de tarauds.

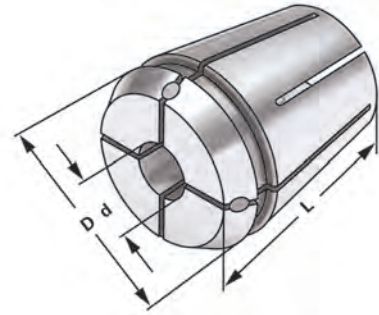

ISO 15488 B
DIN 6499 B

ER

$\nabla \leq 0,015$

14.04

Bestell-Nr. Order no. Référence	Größe Size Taille	Schaft Shaft Queue d	Vierkant Square Carré	D	L
426GA-3527	ER 16	3,5	2,7	16,8	27,5
426GA-43	ER 16	4	3	16,8	27,5
426GA-4534	ER 16	4,5	3,4	16,8	27,5
426GA-649	ER 16	6	4,9	16,8	27,5
426GA-755	ER 16	7	5,5	16,8	27,5
426GA-862	ER 16	8	6,2	16,8	27,5

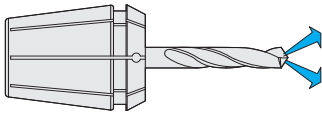



Spannzangen ISO 15488 B (DIN 6499 B) System ER

Collets ISO 15488 B (DIN 6499 B) ER-system

Pinces de serrage ISO 15488 B (DIN 6499 B) système ER



Verwendung:

Zur Aufnahme von Werkzeugen mit Zylinderschaft in Spannfutter DIN 6499.

Application:

For mounting straight-shank tools in collet chucks DIN 6499.

Application:

Pour le serrage d'outils avec queue cylindrique dans mandrins à pinces DIN 6499.

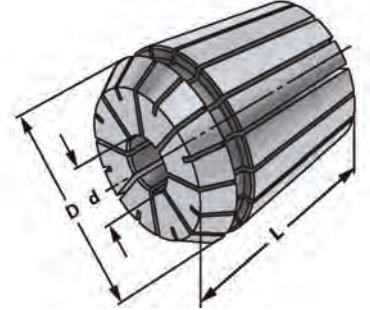

ISO 15488 B
DIN 6499 B

ER

$\lambda \leq 0,015$



Bestell-Nr. Order no. Référence	Größe Size Taille	d	D	L
428E-02	ER 20	2 - 1,5	21	31,5
428E-03	ER 20	3 - 2,0	21	31,5
428E-04	ER 20	4 - 3,0	21	31,5
428E-05	ER 20	5 - 4,0	21	31,5
428E-06	ER 20	6 - 5,0	21	31,5
428E-07	ER 20	7 - 6,0	21	31,5
428E-08	ER 20	8 - 7,0	21	31,5
428E-09	ER 20	9 - 8,0	21	31,5
428E-10	ER 20	10 - 9,0	21	31,5
428E-11	ER 20	11 - 10,0	21	31,5
428E-12	ER 20	12 - 11,0	21	31,5
428E-13	ER 20	13 - 12,0	21	31,5

Hinweis: Hohe Flexibilität: Großer Spannbereich bis -1 mm
Note: High flexibility: Large holding capacity up to -1 mm
Observation: Grande capacité de serrage jusqu'à -1 mm



Precision collets ISO 15488 B (DIN 6499 B) ER-system

Pinces de serrage de précision ISO 15488 B (DIN 6499 B) système ER

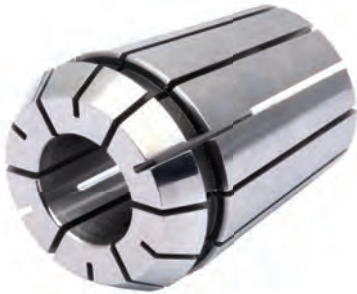

Verwendung:

Zur Aufnahme von Werkzeugen mit Zylinderschaft in Spannfutter DIN 6499. Für Anwendungen im HSC-Bereich und für hochpräzise Bearbeitungsergebnisse.

Application:

For mounting straight-shank tools in collet chucks DIN 6499. To use for high speed cutting and high precision milling.

Application:

Pour le serrage d'outils avec queue cylindrique dans mandrins à pinces DIN 6499. Pour l'usage dans le coupage à grande vitesse et dans l'usinage à grande précision.

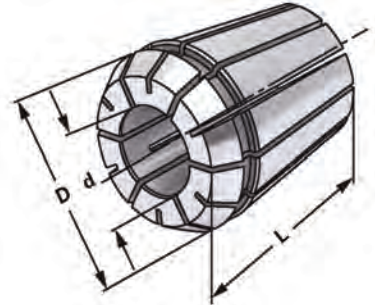

ISO 15488 B
DIN 6499 B

ER

$\lambda \leq 0,005$

14.04

Bestell-Nr. Order no. Référence	Größe Size Taille	d	D	L
428EP-02	ER 20	2 - 1,5	21	31,5
428EP-03	ER 20	3 - 2,0	21	31,5
428EP-04	ER 20	4 - 3,0	21	31,5
428EP-05	ER 20	5 - 4,0	21	31,5
428EP-06	ER 20	6 - 5,0	21	31,5
428EP-07	ER 20	7 - 6,0	21	31,5
428EP-08	ER 20	8 - 7,0	21	31,5
428EP-09	ER 20	9 - 8,0	21	31,5
428EP-10	ER 20	10 - 9,0	21	31,5
428EP-11	ER 20	11 - 10,0	21	31,5
428EP-12	ER 20	12 - 11,0	21	31,5
428EP-13	ER 20	13 - 12,0	21	31,5

Hinweis: Hohe Flexibilität: Großer Spannbereich bis -1 mm
Note: High flexibility: Large holding capacity up to -1 mm
Observation: Grande capacité de serrage jusqu'à -1 mm





Spannzangen mit Abdichtung für IK - ISO 15488 B (DIN 6499 B) System ER

Collets sealed for IC - ISO 15488 B (DIN 6499 B) ER-system

Pinces de serrage avec joint d'étanchéité pour IC - ISO 15488 B (DIN 6499 B) système ER



Verwendung:

Zur Aufnahme von Werkzeugen mit Innenkühlung und Zylinderschaft in Spannfutter DIN 6499

Application:

For mounting straight-shank tools with internal cooling in collet chucks DIN 6499

Application:

Pour le serrage des outils avec le refroidissement interne et avec queue cylindrique dans mandrins à pinces DIN 6499

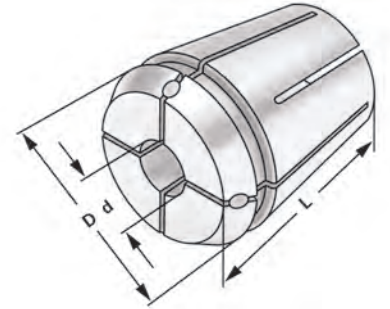

ISO 15488 B
DIN 6499 B

ER

$\nabla \leq 0,015$



Bestell-Nr. Order no. Référence	Größe Size Taille	d	D	L
428EA-03	ER 20	3	21	31,5
428EA-04	ER 20	4	21	31,5
428EA-05	ER 20	5	21	31,5
428EA-06	ER 20	6	21	31,5
428EA-07	ER 20	7	21	31,5
428EA-08	ER 20	8	21	31,5
428EA-09	ER 20	9	21	31,5
428EA-10	ER 20	10	21	31,5
428EA-11	ER 20	11	21	31,5
428EA-12	ER 20	12	21	31,5
428EA-13	ER 20	13	21	31,5

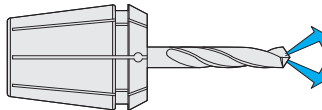

9

Hinweis:

Nur das Nennmaß d kann gespannt werden, mit Dichtstopfen für Innenkühlung (einsetzbar bis 21 bar). Um eine optimale Abdichtung zu erreichen, muss das zu spannende Werkzeug auf der ganzen Länge der geschliffenen Bohrung der Spannzange eingespannt werden.

Note:

Only nominal size d can be clamped with sealing plug for internal cooling (applicable up to 21 bar). In order to achieve an optimum sealing the tool must be clamped on the complete length of the ground drill of the collet.

Observation:

Seulement la dimension nominale d peut être tendu avec des bochons 'étanchéité pour le refroidissement interne (peut être utilisé jusqu'à 21 bar). Afin d'obtenir un étanchéité optimal l'outil doit être serré sur la longueur complète de l'alésage rectifié de la pince.



Collets steel sealed for high pressure cooling until 120 bar
 Pincettes de serrage, étanche pour arrosage de haute pression 120 bar



Verwendung:
 Zur Aufnahme von Werkzeugen mit Innenkühlung und Zylinderschaft in Spannfutter DIN 6499

Application:
 For mounting straight-shank tools with internal cooling in collet chucks DIN 6499

Application:
 Pour le serrage des outils avec le refroidissement interne et avec queue cylindrique dans mandrins à pincettes DIN 6499

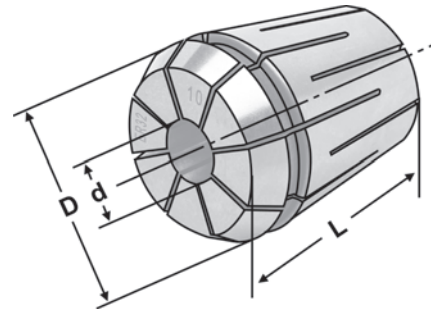

ISO 15488 B
 DIN 6499 B

ER

$\nabla \leq 0,015$



Bestell-Nr. Order no. Référence	Größe Size Taille	d	D	L
428EH-03	ER 20	3	21	31,5
428EH-04	ER 20	4	21	31,5
428EH-05	ER 20	5	21	31,5
428EH-06	ER 20	6	21	31,5
428EH-07	ER 20	7	21	31,5
428EH-08	ER 20	8	21	31,5
428EH-09	ER 20	9	21	31,5
428EH-10	ER 20	10	21	31,5
428EH-11	ER 20	11	21	31,5
428EH-12	ER 20	12	21	31,5
428EH-13	ER 20	13	21	31,5

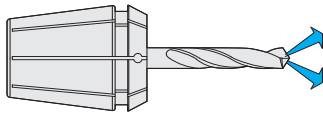

Hinweis: Nur das Nennmaß d kann gespannt werden (einsetzbar bis 120 bar). Um eine optimale Abdichtung zu erreichen, muss das zu spannende Werkzeug auf der ganzen Länge der geschliffenen Bohrung der Spannzange eingespannt werden.

Note: Only nominal size d can be clamped (applicable up to 120 bar). In order to achieve an optimum sealing the tool must be clamped on the complete length of the ground drill of the collet.

Observation: Seulement la dimension nominale d peut être tendu (peut être utilisé jusqu'à 120 bar). Afin d'obtenir un étanchéité optimal l'outil doit être serré sur la longueur complète de l'alésage rectifié de la pince.





Spannzangen mit Kühlkanalbohrungen ISO 15488 B (DIN 6499 B) System ER

Collets with cooling channels ISO 15488 B (DIN 6499 B) ER-system

Pincettes de serrage avec canaux d'arrosage ISO 15488 B (DIN 6499 B) système ER



Verwendung:

Zur Aufnahme von Werkzeugen mit Zylinderschaft in Spannfutter DIN 6499.

Application:

For mounting straight-shank tools in collet chucks DIN 6499.

Application:

Pour le serrage d'outils avec queue cylindrique dans mandrins à pincettes DIN 6499.

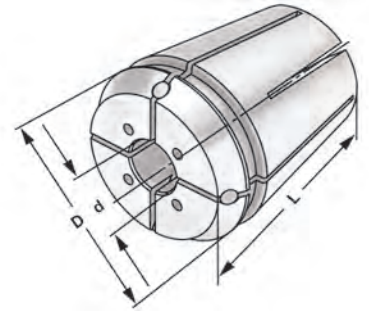

ISO 15488 B
DIN 6499 B

ER

$\nabla \leq 0,015$



Bestell-Nr. Order no. Référence	Größe Size Taille	d	D	L
428EC-04	ER 20	4	21	31,5
428EC-05	ER 20	5	21	31,5
428EC-06	ER 20	6	21	31,5
428EC-07	ER 20	7	21	31,5
428EC-08	ER 20	8	21	31,5
428EC-09	ER 20	9	21	31,5



Hinweis:

Nur das Nennmaß d kann gespannt werden, mit Kühlkanälen. Einsetzbar bis 21 bar. Um eine optimale Abdichtung zu erreichen, muss das zu spannende Werkzeug auf der ganzen Länge der geschliffenen Bohrung der Spannzange eingespannt werden.

Note:

Only nominal size d can be clamped, with cooling channels. Applicable up to 21 bar. In order to achieve an optimum sealing the tool must be clamped on the complete length of the ground drill of the collet.

Observation:

Seulement la dimension nominale d peut être tendu, avec canaux d'arrosage. Peut être utilisé jusqu'à 21 bar. Afin d'obtenir un étanchéité optimal l'outil doit être serré sur la longueur complète de l'alésage rectifié de la pince.

9



ISO 15488 B (DIN 6499 B) System ER

Collets with cooling channels along the boring ISO 15488 B (DIN 6499 B) ER-system

Pinces de serrage avec canaux d'arrosage le long de l'alésage ISO 15488 B (DIN 6499 B) système ER



Verwendung:

Zur Aufnahme von Werkzeugen mit Zylinderschaft in Spannfutter DIN 6499.

Application:

For mounting straight-shank tools in collet chucks DIN 6499.

Application:

Pour le serrage d'outils avec queue cylindrique dans mandrins à pinces DIN 6499.

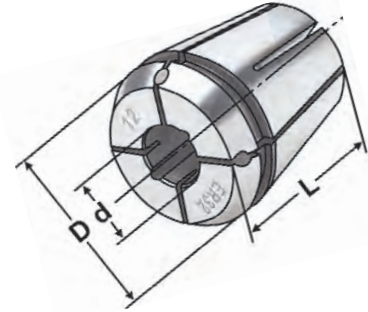

ISO 15488 B
DIN 6499 B

ER

$\nabla \leq 0,015$

14.04

Bestell-Nr. Order no. Référence	Größe Size Taille	d	D	L
428ECC-04	ER 20	4	21	31,5
428ECC-05	ER 20	5	21	31,5
428ECC-06	ER 20	6	21	31,5
428ECC-07	ER 20	7	21	31,5
428ECC-08	ER 20	8	21	31,5
428ECC-09	ER 20	9	21	31,5



Hinweis: Nur das Nennmaß d kann gespannt werden, mit Kühlkanälen entlang der Bohrung. Einsetzbar bis 21 bar. Um eine optimale Abdichtung zu erreichen, muss das zu spannende Werkzeug auf der ganzen Länge der geschliffenen Bohrung der Spannzange eingespannt werden.

Note: Only nominal size d can be clamped, with cooling channels along the boring. Applicable up to 21 bar. In order to achieve an optimum sealing the tool must be clamped on the complete length of the ground drill of the collet.

Observation: Seulement la dimension nominale d peut être tendu, avec canaux d'arrosage le long de l'alésage. Peut être utilisé jusqu'à 21 bar. Afin d'obtenir un étanchéité optimal l'outil doit être serré sur la longueur complète de l'alésage rectifié de la pince.





Präzisionsspannzangen ISO 15488 B (DIN 6499 B) System ER - Edelstahl

Precision collets ISO 15488 B (DIN 6499 B) ER-system - stainless steel

Pincès de serrage de précision ISO 15488 B (DIN 6499 B) système ER - acier inoxydable



Verwendung:

Zur Aufnahme von Werkzeugen mit Zylinderschaft in Spannfutter DIN 6499. Für Anwendungen im HSC-Bereich und für hochpräzise Bearbeitungsergebnisse.

Application:

For mounting straight-shank tools in collet chucks DIN 6499. To use for high speed cutting and high precision milling.

Application:

Pour le serrage d'outils avec queue cylindrique dans mandrins à pincès DIN 6499. Pour l'usage dans le coupage à grande vitesse et dans l'usinage à grande précision.

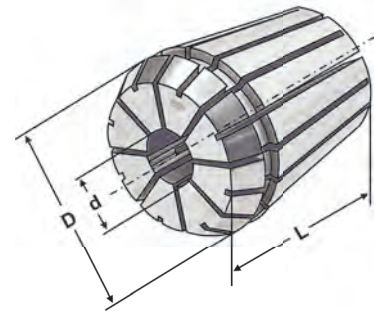

ISO 15488 B
DIN 6499 B

ER

$\nabla \leq 0,005$



Bestell-Nr. Order no. Référence	Größe Size Taille	d	D	L
428ESP-03	ER 20	3,0 - 2,5	21	31,5
428ESP-035	ER 20	3,5 - 3,0	21	31,5
428ESP-04	ER 20	4,0 - 3,5	21	31,5
428ESP-045	ER 20	4,5 - 4,0	21	31,5
428ESP-05	ER 20	5,0 - 4,5	21	31,5
428ESP-055	ER 20	5,5 - 5,0	21	31,5
428ESP-06	ER 20	6,0 - 5,5	21	31,5
428ESP-065	ER 20	6,5 - 6,0	21	31,5
428ESP-07	ER 20	7,0 - 6,5	21	31,5
428ESP-075	ER 20	7,5 - 7,0	21	31,5
428ESP-08	ER 20	8,0 - 7,5	21	31,5
428ESP-085	ER 20	8,5 - 8,0	21	31,5
428ESP-09	ER 20	9,0 - 8,5	21	31,5
428ESP-095	ER 20	9,5 - 9,0	21	31,5
428ESP-10	ER 20	10,0 - 9,5	21	31,5
428ESP-105	ER 20	10,5 - 10,0	21	31,5
428ESP-11	ER 20	11,0 - 10,5	21	31,5
428ESP-115	ER 20	11,5 - 11,0	21	31,5
428ESP-12	ER 20	12,0 - 11,5	21	31,5
428ESP-125	ER 20	12,5 - 12,0	21	31,5
428ESP-13	ER 20	13,0 - 12,5	21	31,5

9

Hinweis: Spannbereich bis -0,5 mm
Note: Clamping capacity up to -0,5 mm
Observation: Serrage jusqu'à -0,5 mm

- Rostfrei
- Edelstahl 1.4021 x 20Cr13
- Höhere Wiederholgenauigkeit
- Spannzangenbohrung gehont
- Besonders geeignet für Drahterosion

- Rustproof
- Stainless steel 1.4021 x 20Cr13
- Higher repeat-accuracy
- Honed collet boring
- Especially suitable for wire EDM

- Inoxydable
- Acier affiné 1.4021 x 20Cr13
- Répétabilité supérieure
- Alésage de pince aiguisé
- Convient particulièrement pour le fil EDM



9.71



9.71



10.11

Tap collets - ISO 15488 B (DIN 6499 B) System ER

Pinces de serrage pour tarauds - ISO 15488 B (DIN 6499 B) System ER



Verwendung:
Für Maschinen mit steigungssynchronem Vorschub. Zur verkehrsicheren Spannung von Gewindebohrern.

Application:
For machines with rigid tapping.
For safe clamping of taps.

Application:
Pour machines avec broche synchronisée.
Pour le serrage stable de tarauds.

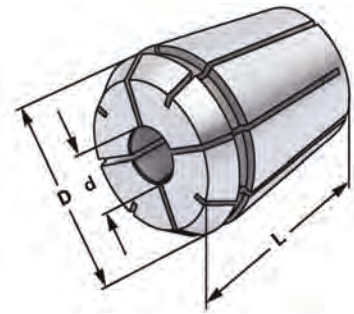

ISO 15488 B
DIN 6499 B

ER

$\nabla \leq 0,015$



Bestell-Nr. Order no. Référence	Größe Size Taille	Schaft Shaft Queue d	Vierkant Square Carré	D	L
428G-3527	ER 20	3,5	2,7	20,8	31,5
428G-43	ER 20	4	3	20,8	31,5
428G-4534	ER 20	4,5	3,4	20,8	31,5
428G-649	ER 20	6	4,9	20,8	31,5
428G-755	ER 20	7	5,5	20,8	31,5
428G-862	ER 20	8	6,2	20,8	31,5
428G-97	ER 20	9	7	20,8	31,5
428G-108	ER 20	10	8	20,8	31,5





Gewindebohrer Spannzangen mit Kühkanalbohrungen

Tap collets with cooling channels
Pincettes de serrage avec canaux d'arrosage



Verwendung:
Für Maschinen mit steigungssynchronem Vorschub. Zur verdrehsicheren Spannung von Gewindebohrern.

Application:
For machines with rigid tapping.
For safe clamping of taps.

Application:
Pour machines avec broche synchronisée.
Pour le serrage stable de tarauds.

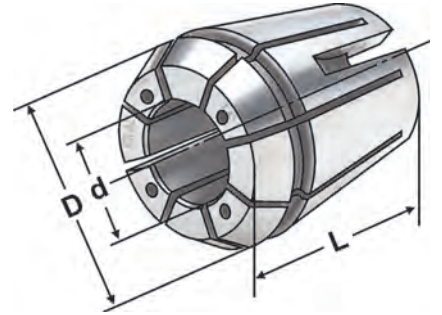

ISO 15488 B
DIN 6499 B

ER

$\nabla \leq 0,015$



Bestell-Nr. Order no. Référence	Größe Size Taille	Schaft Shaft Queue	Vierkant Square Carré	D	L
428GC-3527	ER 20	3,5	2,7	20,8	31,5
428GC-43	ER 20	4	3	20,8	31,5
428GC-4534	ER 20	4,5	3,4	20,8	31,5
428GC-649	ER 20	6	4,9	20,8	31,5
428GC-755	ER 20	7	5,5	20,8	31,5
428GC-862	ER 20	8	6,2	20,8	31,5
428GC-97	ER 20	9	7	20,8	31,5
428GC-108	ER 20	10	8	20,8	31,5



Gewindebohrer Spannzangen mit Dichtstopfen



Tap collets with seals
Pincettes de serrage pour tarauds



Verwendung:
Für Maschinen mit steigungssynchronem Vorschub. Zur verdrehsicheren Spannung von Gewindebohrern.

Application:
For machines with rigid tapping. For safe clamping of taps.

Application:
Pour machines avec broche synchronisée. Pour le serrage stable de tarauds.

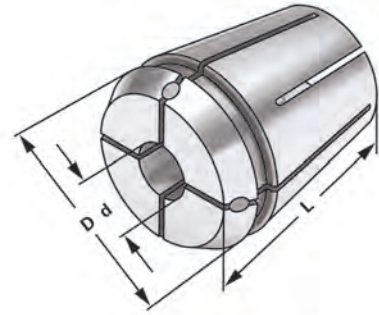

ISO 15488 B
DIN 6499 B

ER

$\nabla \leq 0,015$

14.04

Bestell-Nr. Order no. Référence	Größe Size Taille	Schaft Shaft Queue d	Vierkant Square Carré	D	L
428GA-3527	ER 20	3,5	2,7	20,8	31,5
428GA-43	ER 20	4	3	20,8	31,5
428GA-4534	ER 20	4,5	3,4	20,8	31,5
428GA-649	ER 20	6	4,9	20,8	31,5
428GA-755	ER 20	7	5,5	20,8	31,5
428GA-862	ER 20	8	6,2	20,8	31,5
428GA-97	ER 20	9	7	20,8	31,5
428GA-108	ER 20	10	8	20,8	31,5

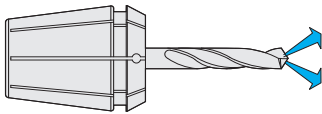



Spannzangen ISO 15488 B (DIN 6499 B) System ER

Collets ISO 15488 B (DIN 6499 B) ER-system

Pinces de serrage ISO 15488 B (DIN 6499 B) système ER



Verwendung:

Zur Aufnahme von Werkzeugen mit Zylinderschaft in Spannfutter DIN 6499.

Application:

For mounting straight-shank tools in collet chucks DIN 6499.

Application:

Pour le serrage d'outils avec queue cylindrique dans mandrins à pinces DIN 6499.

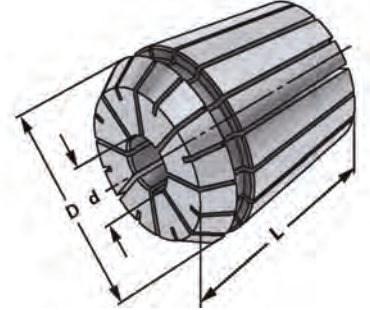

ISO 15488 B
DIN 6499 B

ER

$\nabla \leq 0,015$



Bestell-Nr. Order no. Référence	Größe Size Taille	d	D	L
430E-02	ER 25	2 - 1,5	26	34
430E-03	ER 25	3 - 2,0	26	34
430E-04	ER 25	4 - 3,0	26	34
430E-05	ER 25	5 - 4,0	26	34
430E-06	ER 25	6 - 5,0	26	34
430E-07	ER 25	7 - 6,0	26	34
430E-08	ER 25	8 - 7,0	26	34
430E-09	ER 25	9 - 8,0	26	34
430E-10	ER 25	10 - 9,0	26	34
430E-11	ER 25	11 - 10,0	26	34
430E-12	ER 25	12 - 11,0	26	34
430E-13	ER 25	13 - 12,0	26	34
430E-14	ER 25	14 - 13,0	26	34
430E-15	ER 25	15 - 14,0	26	34
430E-16	ER 25	16 - 15,0	26	34

9

Hinweis: Hohe Flexibilität: Großer Spannbereich bis -1 mm
Note: High flexibility: Large holding capacity up to -1 mm
Observation: Grande capacité de serrage jusqu'à -1 mm



9.35

Precision collets ISO 15488 B (DIN 6499 B) ER-system

Pinces de serrage de précision ISO 15488 B (DIN 6499 B) système ER

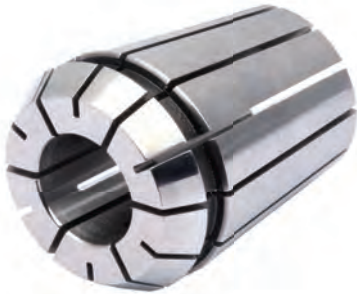

Verwendung:

Zur Aufnahme von Werkzeugen mit Zylinderschaft in Spannfutter DIN 6499. Für Anwendungen im HSC-Bereich und für hochpräzise Bearbeitungsergebnisse.

Application:

For mounting straight-shank tools in collet chucks DIN 6499. To use for high speed cutting and high precision milling.

Application:

Pour le serrage d'outils avec queue cylindrique dans mandrins à pinces DIN 6499. Pour l'usage dans le coupage à grande vitesse et dans l'usinage à grande précision.

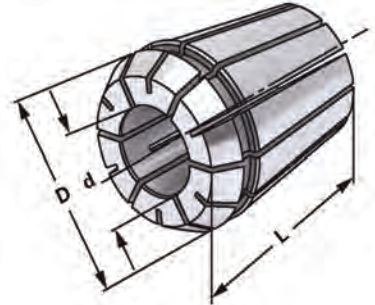

ISO 15488 B
DIN 6499 B

ER

$\lambda \leq 0,005$

14.04

Bestell-Nr. Order no. Référence	Größe Size Taille	d	D	L
430EP-02	ER 25	2 - 1,5	26	34
430EP-03	ER 25	3 - 2,0	26	34
430EP-04	ER 25	4 - 3,0	26	34
430EP-05	ER 25	5 - 4,0	26	34
430EP-06	ER 25	6 - 5,0	26	34
430EP-07	ER 25	7 - 6,0	26	34
430EP-08	ER 25	8 - 7,0	26	34
430EP-09	ER 25	9 - 8,0	26	34
430EP-10	ER 25	10 - 9,0	26	34
430EP-11	ER 25	11 - 10,0	26	34
430EP-12	ER 25	12 - 11,0	26	34
430EP-13	ER 25	13 - 12,0	26	34
430EP-14	ER 25	14 - 13,0	26	34
430EP-15	ER 25	15 - 14,0	26	34
430EP-16	ER 25	16 - 15,0	26	34

Hinweis: Hohe Flexibilität: Großer Spannbereich bis -1 mm
Note: High flexibility: Large holding capacity up to -1 mm
Observation: Grande capacité de serrage jusqu'à -1 mm





Spannzangen mit Abdichtung für IK - ISO 15488 B (DIN 6499 B) System ER

Collets sealed for IC - ISO 15488 B (DIN 6499 B) ER-system

Pincettes de serrage avec joint d'étanchéité pour IC - ISO 15488 B (DIN 6499 B) système ER



Verwendung:

Zur Aufnahme von Werkzeugen mit Innenkühlung und Zylinderschaft in Spannfutter DIN 6499

Application:

For mounting straight-shank tools with internal cooling in collet chucks DIN 6499

Application:

Pour le serrage des outils avec le refroidissement interne et avec queue cylindrique dans mandrins à pinces DIN 6499

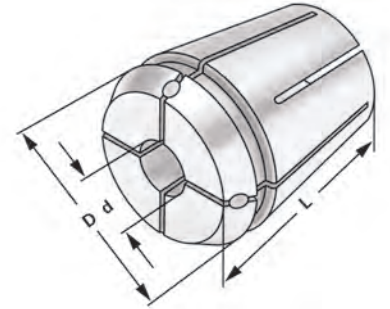

ISO 15488 B
DIN 6499 B

ER

$\nabla \leq 0,015$



Bestell-Nr. Order no. Référence	Größe Size Taille	d	D	L
430EA-03	ER 25	3	26	34
430EA-04	ER 25	4	26	34
430EA-05	ER 25	5	26	34
430EA-06	ER 25	6	26	34
430EA-07	ER 25	7	26	34
430EA-08	ER 25	8	26	34
430EA-09	ER 25	9	26	34
430EA-10	ER 25	10	26	34
430EA-11	ER 25	11	26	34
430EA-12	ER 25	12	26	34
430EA-13	ER 25	13	26	34
430EA-14	ER 25	14	26	34
430EA-15	ER 25	15	26	34
430EA-16	ER 25	16	26	34

9

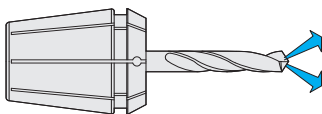

Hinweis:

Nur das Nennmaß d kann gespannt werden, mit Dichtstopfen für Innenkühlung (einsetzbar bis 21 bar). Um eine optimale Abdichtung zu erreichen, muss das zu spannende Werkzeug auf der ganzen Länge der geschliffenen Bohrung der Spannzange eingespannt werden.

Note:

Only nominal size d can be clamped with sealing plug for internal cooling (applicable up to 21 bar). In order to achieve an optimum sealing the tool must be clamped on the complete length of the ground drill of the collet.

Observation:

Seulement la dimension nominale d peut être tendu avec des bochons 'étanchéité pour le refroidissement interne (peut être utilisé jusqu'à 21 bar). Afin d'obtenir un étanchéité optimal l'outil doit être serré sur la longueur complète de l'alésage rectifié de la pince.



Spannzangen abgedichtet für Hochdruckkühlung bis 120 bar



Collets steel sealed for high pressure cooling until 120 bar
 Pincettes de serrage, étanche pour arrosage de haute pression 120 bar



Verwendung:
 Zur Aufnahme von Werkzeugen mit Innenkühlung und Zylinderschaft in Spannfutter DIN 6499

Application:
 For mounting straight-shank tools with internal cooling in collet chucks DIN 6499

Application:
 Pour le serrage des outils avec le refroidissement interne et avec queue cylindrique dans mandrins à pincettes DIN 6499

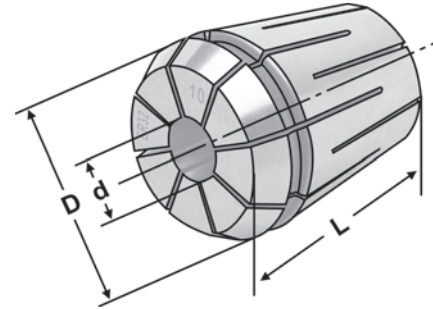

ISO 15488 B
 DIN 6499 B

ER

$\lambda \leq 0,015$

14.04

Bestell-Nr. Order no. Référence	Größe Size Taille	d	D	L
430EH-03	ER 25	3	26	34
430EH-04	ER 25	4	26	34
430EH-05	ER 25	5	26	34
430EH-06	ER 25	6	26	34
430EH-07	ER 25	7	26	34
430EH-08	ER 25	8	26	34
430EH-09	ER 25	9	26	34
430EH-10	ER 25	10	26	34
430EH-11	ER 25	11	26	34
430EH-12	ER 25	12	26	34
430EH-13	ER 25	13	26	34
430EH-14	ER 25	14	26	34
430EH-15	ER 25	15	26	34
430EH-16	ER 25	16	26	34

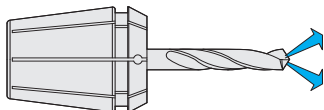

9

Hinweis: Nur das Nennmaß d kann gespannt werden (einsetzbar bis 120 bar). Um eine optimale Abdichtung zu erreichen, muss das zu spannende Werkzeug auf der ganzen Länge der geschliffenen Bohrung der Spannzange eingespannt werden.

Note: Only nominal size d can be clamped (applicable up to 120 bar). In order to achieve an optimum sealing the tool must be clamped on the complete length of the ground drill of the collet.

Observation: Seulement la dimension nominale d peut être tendu (peut être utilisé jusqu'à 120 bar). Afin d'obtenir un étanchéité optimal l'outil doit être serré sur la longueur complète de l'alésage rectifié de la pince.





Spannzangen mit Kühlkanalbohrungen ISO 15488 B (DIN 6499 B) System ER

Collets with cooling channels ISO 15488 B (DIN 6499 B) ER-system

Pinces de serrage avec canaux d'arrosage ISO 15488 B (DIN 6499 B) système ER



Verwendung:

Zur Aufnahme von Werkzeugen mit Zylinderschaft in Spannfutter DIN 6499.

Application:

For mounting straight-shank tools in collet chucks DIN 6499.

Application:

Pour le serrage d'outils avec queue cylindrique dans mandrins à pinces DIN 6499.

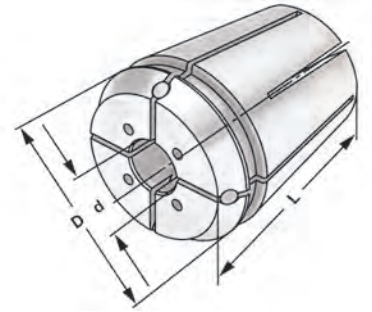

ISO 15488 B
DIN 6499 B

ER

$\nabla \leq 0,015$



Bestell-Nr. Order no. Référence	Größe Size Taille	d	D	L
430EC-03	ER 25	3	26	34
430EC-04	ER 25	4	26	34
430EC-05	ER 25	5	26	34
430EC-06	ER 25	6	26	34
430EC-07	ER 25	7	26	34
430EC-08	ER 25	8	26	34
430EC-09	ER 25	9	26	34
430EC-10	ER 25	10	26	34
430EC-11	ER 25	11	26	34
430EC-12	ER 25	12	26	34
430EC-13	ER 25	13	26	34
430EC-14	ER 25	14	26	34



9

Hinweis:

Nur das Nennmaß d kann gespannt werden, mit Kühlkanälen. Einsetzbar bis 21 bar. Um eine optimale Abdichtung zu erreichen, muss das zu spannende Werkzeug auf der ganzen Länge der geschliffenen Bohrung der Spannzange eingespannt werden.

Note:

Only nominal size d can be clamped, with cooling channels. Applicable up to 21 bar. In order to achieve an optimum sealing the tool must be clamped on the complete length of the ground drill of the collet.

Observation:

Seulement la dimension nominale d peut être tendu, avec canaux d'arrosage. Peut être utilisé jusqu'à 21 bar. Afin d'obtenir un étanchéité optimal l'outil doit être serré sur la longueur complète de l'alésage rectifié de la pince.



9.69



9.69



10.11

ISO 15488 B (DIN 6499 B) System ER

Collets with cooling channels along the boring ISO 15488 B (DIN 6499 B) ER-system

Pinces de serrage avec canaux d'arrosage le long de l'alésage ISO 15488 B (DIN 6499 B) système ER



Verwendung:
Zur Aufnahme von Werkzeugen mit Zylinderschaft in Spannfutter DIN 6499.

Application:
For mounting straight-shank tools in collet chucks DIN 6499.

Application:
Pour le serrage d'outils avec queue cylindrique dans mandrins à pinces DIN 6499.

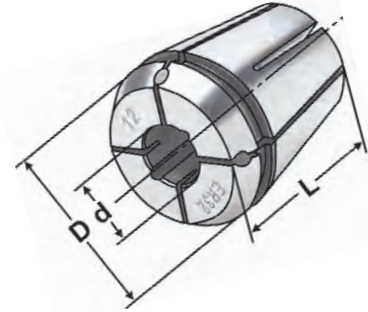

ISO 15488 B
DIN 6499 B

ER

$\lambda \leq 0,015$

14.04

Bestell-Nr. Order no. Référence	Größe Size Taille	d	D	L
430ECC-03	ER 25	3	26	34
430ECC-04	ER 25	4	26	34
430ECC-05	ER 25	5	26	34
430ECC-06	ER 25	6	26	34
430ECC-07	ER 25	7	26	34
430ECC-08	ER 25	8	26	34
430ECC-09	ER 25	9	26	34
430ECC-10	ER 25	10	26	34
430ECC-11	ER 25	11	26	34
430ECC-12	ER 25	12	26	34
430ECC-13	ER 25	13	26	34
430ECC-14	ER 25	14	26	34



Hinweis: Nur das Nennmaß d kann gespannt werden, mit Kühlkanälen entlang der Bohrung. Einsetzbar bis 21 bar. Um eine optimale Abdichtung zu erreichen, muss das zu spannende Werkzeug auf der ganzen Länge der geschliffenen Bohrung der Spannzange eingespannt werden.

Note: Only nominal size d can be clamped, with cooling channels along the boring. Applicable up to 21 bar. In order to achieve an optimum sealing the tool must be clamped on the complete length of the ground drill of the collet.

Observation: Seulement la dimension nominale d peut être tendu, avec canaux d'arrosage le long de l'alésage. Peut être utilisé jusqu'à 21 bar. Afin d'obtenir un étanchéité optimal l'outil doit être serré sur la longueur complète de l'alésage rectifié de la pince.





Präzisionsspannzangen ISO 15488 B (DIN 6499 B) System ER - Edelstahl

Precision collets ISO 15488 B (DIN 6499 B) ER-system - stainless steel

Pinces de serrage de précision ISO 15488 B (DIN 6499 B) système ER - acier inoxydable



Verwendung:

Zur Aufnahme von Werkzeugen mit Zylinderschaft in Spannfutter DIN 6499. Für Anwendungen im HSC-Bereich und für hochpräzise Bearbeitungsergebnisse.

Application:

For mounting straight-shank tools in collet chucks DIN 6499. To use for high speed cutting and high precision milling.

Application:

Pour le serrage d'outils avec queue cylindrique dans mandrins à pinces DIN 6499. Pour l'usage dans le coupage à grande vitesse et dans l'usinage à grande précision.

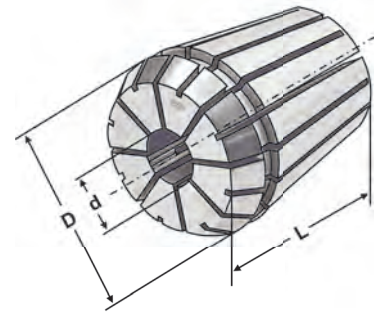

ISO 15488 B
DIN 6499 B

ER

$\lambda \leq 0,005$



Bestell-Nr. Order no. Référence	Größe Size Taille	d	D	L
430ESP-03	ER 25	3,0 - 2,5	26	34
430ESP-035	ER 25	3,5 - 3,0	26	34
430ESP-04	ER 25	4,0 - 3,5	26	34
430ESP-045	ER 25	4,5 - 4,0	26	34
430ESP-05	ER 25	5,0 - 4,5	26	34
430ESP-055	ER 25	5,5 - 5,0	26	34
430ESP-06	ER 25	6,0 - 5,5	26	34
430ESP-065	ER 25	6,5 - 6,0	26	34
430ESP-07	ER 25	7,0 - 6,5	26	34
430ESP-075	ER 25	7,5 - 7,0	26	34
430ESP-08	ER 25	8,0 - 7,5	26	34
430ESP-085	ER 25	8,5 - 8,0	26	34
430ESP-09	ER 25	9,0 - 8,5	26	34
430ESP-095	ER 25	9,5 - 9,0	26	34
430ESP-10	ER 25	10,0 - 9,5	26	34
430ESP-105	ER 25	10,5 - 10,0	26	34
430ESP-11	ER 25	11,0 - 10,5	26	34
430ESP-115	ER 25	11,5 - 11,0	26	34
430ESP-12	ER 25	12,0 - 11,5	26	34
430ESP-125	ER 25	12,5 - 12,0	26	34
430ESP-13	ER 25	13,0 - 12,5	26	34
430ESP-135	ER 25	13,5 - 13,0	26	34
430ESP-14	ER 25	14,0 - 13,5	26	34
430ESP-145	ER 25	14,5 - 14,0	26	34
430ESP-15	ER 25	15,0 - 14,5	26	34
430ESP-155	ER 25	15,5 - 15,0	26	34
430ESP-16	ER 25	16,0 - 15,5	26	34

- Rostfrei
- Edelstahl 1.4021 x 20Cr13
- Höhere Wiederholgenauigkeit
- Spannzangenbohrung gehont
- Besonders geeignet für Drahterosion

- Rustproof
- Stainless steel 1.4021 x 20Cr13
- Higher repeat-accuracy
- Honed collet boring
- Especially suitable fore wire EDM

- Inoxydable
- Acier affiné 1.4021 x 20Cr13
- Répétabilité supérieure
- Alésage de pince aiguisé
- Convient particulièrement pour le fil EDM



Tap collets - ISO 15488 B (DIN 6499 B) System ER

Pinces de serrage pour tarauds - ISO 15488 B (DIN 6499 B) System ER



Verwendung:
Für Maschinen mit steigungssynchronem Vorschub. Zur verkehrsicheren Spannung von Gewindebohrern.

Application:
For machines with rigid tapping.
For safe clamping of taps.

Application:
Pour machines avec broche synchronisée.
Pour le serrage stable de tarauds.

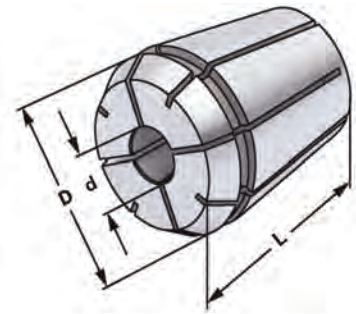

ISO 15488 B
DIN 6499 B

ER

$\nabla \leq 0,015$

14.04

Bestell-Nr. Order no. Référence	Größe Size Taille	Schaft Shaft Queue d	Vierkant Square Carré	D	L
430G-3527	ER 25	3,5	2,7	26	34
430G-43	ER 25	4	3	26	34
430G-4534	ER 25	4,5	3,4	26	34
430G-649	ER 25	6	4,9	26	34
430G-755	ER 25	7	5,5	26	34
430G-862	ER 25	8	6,2	26	34
430G-97	ER 25	9	7	26	34
430G-108	ER 25	10	8	26	34
430G-119	ER 25	11	9	26	34
430G-129	ER 25	12	9	26	34





Gewindebohrer Spannzangen mit Kühkanalbohrungen

Tap collets with cooling channels
Pincés de serrage avec canaux d'arrosage



Verwendung:
Für Maschinen mit steigungssynchronem Vorschub. Zur verdrehsicheren Spannung von Gewindebohrern.

Application:
For machines with rigid tapping.
For safe clamping of taps.

Application:
Pour machines avec broche synchronisée.
Pour le serrage stable de tarauds.

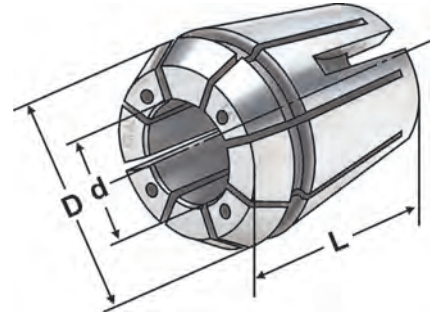

ISO 15488 B
DIN 6499 B

ER

$\nabla \leq 0,015$



Bestell-Nr. Order no. Référence	Größe Size Taille	d	Schaft Shaft Queue	Vierkant Square Carré	D	L
430GC-3527	ER 25	3,5		2,7	25,8	34
430GC-43	ER 25	4		3	25,8	34
430GC-4534	ER 25	4,5		3,4	25,8	34
430GC-649	ER 25	6		4,9	25,8	34
430GC-755	ER 25	7		5,5	25,8	34
430GC-862	ER 25	8		6,2	25,8	34
430GC-97	ER 25	9		7	25,8	34
430GC-108	ER 25	10		8	25,8	34
430GC-119	ER 25	11		9	25,8	34
430GC-129	ER 25	12		9	25,8	34



9.73



9.73



10.11

Tap collets with seals
Pincés de serrage pour tarauds



Verwendung:
Für Maschinen mit steigungssynchronem Vorschub. Zur verdrehsicheren Spannung von Gewindebohrern.

Application:
For machines with rigid tapping. For safe clamping of taps.

Application:
Pour machines avec broche synchronisée. Pour le serrage stable de tarauds.

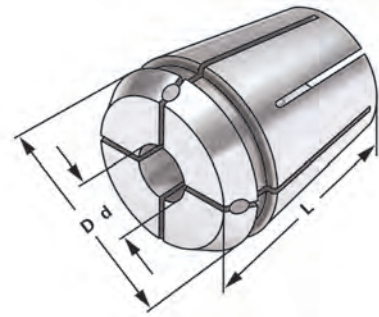

ISO 15488 B
DIN 6499 B

ER

$\nabla \leq 0,015$

14.04

Bestell-Nr. Order no. Référence	Größe Size Taille	Schaft Shaft Queue d	Vierkant Square Carré	D	L
430GA-3527	ER 25	3,5	2,7	25,8	34
430GA-43	ER 25	4	3	25,8	34
430GA-4534	ER 25	4,5	3,4	25,8	34
430GA-649	ER 25	6	4,9	25,8	34
430GA-755	ER 25	7	5,5	25,8	34
430GA-862	ER 25	8	6,2	25,8	34
430GA-97	ER 25	9	7	25,8	34
430GA-108	ER 25	10	8	25,8	34
430GA-119	ER 25	11	9	25,8	34
430GA-129	ER 25	12	9	25,8	34

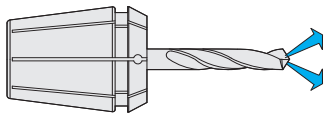



Spannzangen ISO 15488 B (DIN 6499 B) System ER

Collets ISO 15488 B (DIN 6499 B) ER-system

Pincettes de serrage ISO 15488 B (DIN 6499 B) système ER



Verwendung:

Zur Aufnahme von Werkzeugen mit Zylinderschaft in Spannfutter DIN 6499.

Application:

For mounting straight-shank tools in collet chucks DIN 6499.

Application:

Pour le serrage d'outils avec queue cylindrique dans mandrins à pincettes DIN 6499.

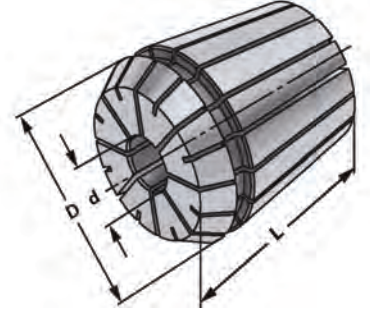

ISO 15488 B
DIN 6499 B

ER

$\nabla \leq 0,015$



Bestell-Nr. Order no. Référence	Größe Size Taille	d	D	L
470E-02	ER 32	2 - 1,5	33	40
470E-03	ER 32	3 - 2,0	33	40
470E-04	ER 32	4 - 3,0	33	40
470E-05	ER 32	5 - 4,0	33	40
470E-06	ER 32	6 - 5,0	33	40
470E-07	ER 32	7 - 6,0	33	40
470E-08	ER 32	8 - 7,0	33	40
470E-09	ER 32	9 - 8,0	33	40
470E-10	ER 32	10 - 9,0	33	40
470E-11	ER 32	11 - 10,0	33	40
470E-12	ER 32	12 - 11,0	33	40
470E-13	ER 32	13 - 12,0	33	40
470E-14	ER 32	14 - 13,0	33	40
470E-15	ER 32	15 - 14,0	33	40
470E-16	ER 32	16 - 15,0	33	40
470E-17	ER 32	17 - 16,0	33	40
470E-18	ER 32	18 - 17,0	33	40
470E-19	ER 32	19 - 18,0	33	40
470E-20	ER 32	20 - 19,0	33	40

Hinweis:

Note:

Observation:

Hohe Flexibilität: Großer Spannbereich bis -1 mm

High flexibility: Large holding capacity up to -1 mm

Grande capacité de serrage jusqu'à -1 mm



Precision collets ISO 15488 B (DIN 6499 B) ER-system

Pinces de serrage de précision ISO 15488 B (DIN 6499 B) système ER

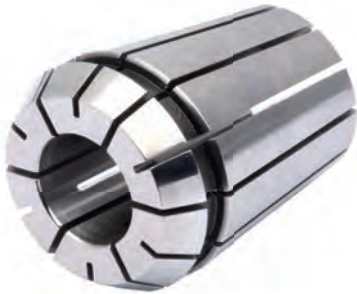

Verwendung:

Zur Aufnahme von Werkzeugen mit Zylinderschaft in Spannfutter DIN 6499. Für Anwendungen im HSC-Bereich und für hochpräzise Bearbeitungsergebnisse.

Application:

For mounting straight-shank tools in collet chucks DIN 6499. To use for high speed cutting and high precision milling.

Application:

Pour le serrage d'outils avec queue cylindrique dans mandrins à pinces DIN 6499. Pour l'usage dans le coupage à grande vitesse et dans l'usinage à grande précision.

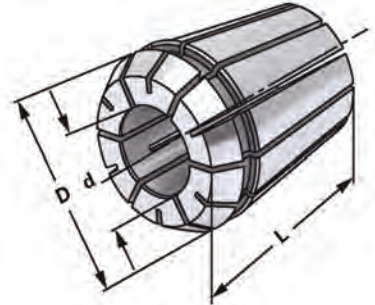

ISO 15488 B
DIN 6499 B

ER

$\lambda \leq 0,005$

14.04

Bestell-Nr. Order no. Référence	Größe Size Taille	d	D	L
470EP-02	ER 32	2 - 1,5	33	40
470EP-03	ER 32	3 - 2,0	33	40
470EP-04	ER 32	4 - 3,0	33	40
470EP-05	ER 32	5 - 4,0	33	40
470EP-06	ER 32	6 - 5,0	33	40
470EP-07	ER 32	7 - 6,0	33	40
470EP-08	ER 32	8 - 7,0	33	40
470EP-09	ER 32	9 - 8,0	33	40
470EP-10	ER 32	10 - 9,0	33	40
470EP-11	ER 32	11 - 10,0	33	40
470EP-12	ER 32	12 - 11,0	33	40
470EP-13	ER 32	13 - 12,0	33	40
470EP-14	ER 32	14 - 13,0	33	40
470EP-15	ER 32	15 - 14,0	33	40
470EP-16	ER 32	16 - 15,0	33	40
470EP-17	ER 32	17 - 16,0	33	40
470EP-18	ER 32	18 - 17,0	33	40
470EP-19	ER 32	19 - 18,0	33	40
470EP-20	ER 32	20 - 19,0	33	40

Hinweis: Hohe Flexibilität: Großer Spannbereich bis -1 mm
Note: High flexibility: Large holding capacity up to -1 mm
Observation: Grande capacité de serrage jusqu'à -1 mm





Spannzangen mit Abdichtung für IK - ISO 15488 B (DIN 6499 B) System ER

Collets sealed for IC - ISO 15488 B (DIN 6499 B) ER-system

Pincettes de serrage avec joint d'étanchéité pour IC - ISO 15488 B (DIN 6499 B) système ER



Verwendung:

Zur Aufnahme von Werkzeugen mit Innenkühlung und Zylinderschaft in Spannfutter DIN 6499

Application:

For mounting straight-shank tools with internal cooling in collet chucks DIN 6499

Application:

Pour le serrage des outils avec le refroidissement interne et avec queue cylindrique dans mandrins à pincettes DIN 6499

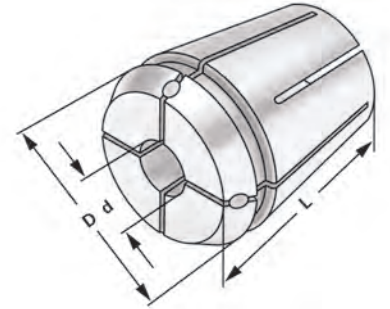

ISO 15488 B
DIN 6499 B

ER

$\nabla \leq 0,015$



Bestell-Nr. Order no. Référence	Größe Size Taille	d	D	L
470EA-03	ER 32	3	33	40
470EA-04	ER 32	4	33	40
470EA-05	ER 32	5	33	40
470EA-06	ER 32	6	33	40
470EA-07	ER 32	7	33	40
470EA-08	ER 32	8	33	40
470EA-09	ER 32	9	33	40
470EA-10	ER 32	10	33	40
470EA-11	ER 32	11	33	40
470EA-12	ER 32	12	33	40
470EA-13	ER 32	13	33	40
470EA-14	ER 32	14	33	40
470EA-15	ER 32	15	33	40
470EA-16	ER 32	16	33	40
470EA-17	ER 32	17	33	40
470EA-18	ER 32	18	33	40
470EA-19	ER 32	19	33	40
470EA-20	ER 32	20	33	40

9

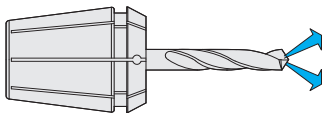

Hinweis:

Nur das Nennmaß d kann gespannt werden, mit Dichtstopfen für Innenkühlung (einsetzbar bis 21 bar). Um eine optimale Abdichtung zu erreichen, muss das zu spannende Werkzeug auf der ganzen Länge der geschliffenen Bohrung der Spannzange eingespannt werden.

Note:

Only nominal size d can be clamped with sealing plug for internal cooling (applicable up to 21 bar). In order to achieve an optimum sealing the tool must be clamped on the complete length of the ground drill of the collet.

Observation:

Seulement la dimension nominale d peut être tendu avec des bochons 'étanchéité pour le refroidissement interne (peut être utilisé jusqu'à 21 bar). Afin d'obtenir un étanchéité optimal l'outil doit être serré sur la longueur complète de l'alésage rectifié de la pince.



9.67



9.67



10.11

Collets steel sealed for high pressure cooling until 120 bar
 Pincettes de serrage, étanche pour arrosage de haute pression 120 bar



Verwendung:
 Zur Aufnahme von Werkzeugen mit Innenkühlung und Zylinderschaft in Spannfutter DIN 6499

Application:
 For mounting straight-shank tools with internal cooling in collet chucks DIN 6499

Application:
 Pour le serrage des outils avec le refroidissement interne et avec queue cylindrique dans mandrins à pincettes DIN 6499

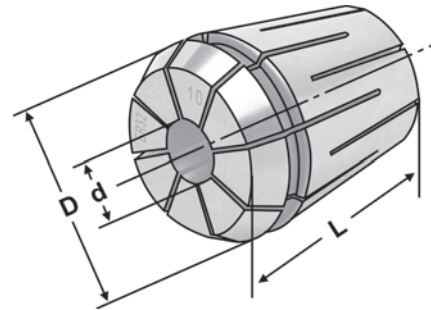

ISO 15488 B
 DIN 6499 B

ER

$\nabla \leq 0,015$

14.04

Bestell-Nr. Order no. Référence	Größe Size Taille	d	D	L
470EH-03	ER 32	3	33	40
470EH-04	ER 32	4	33	40
470EH-05	ER 32	5	33	40
470EH-06	ER 32	6	33	40
470EH-07	ER 32	7	33	40
470EH-08	ER 32	8	33	40
470EH-09	ER 32	9	33	40
470EH-10	ER 32	10	33	40
470EH-11	ER 32	11	33	40
470EH-12	ER 32	12	33	40
470EH-13	ER 32	13	33	40
470EH-14	ER 32	14	33	40
470EH-15	ER 32	15	33	40
470EH-16	ER 32	16	33	40
470EH-17	ER 32	17	33	40
470EH-18	ER 32	18	33	40
470EH-19	ER 32	19	33	40
470EH-20	ER 32	20	33	40

9

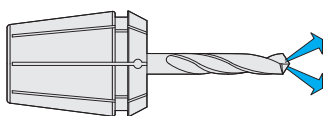

Hinweis: Nur das Nennmaß d kann gespannt werden (einsetzbar bis 120 bar). Um eine optimale Abdichtung zu erreichen, muss das zu spannende Werkzeug auf der ganzen Länge der geschliffenen Bohrung der Spannzange eingespannt werden.

Note: Only nominal size d can be clamped (applicable up to 120 bar). In order to achieve an optimum sealing the tool must be clamped on the complete length of the ground drill of the collet.

Observation: Seulement la dimension nominale d peut être tendu (peut être utilisé jusqu'à 120 bar). Afin d'obtenir un étanchéité optimal l'outil doit être serré sur la longueur complète de l'alésage rectifié de la pince.





Spannzangen mit Dichtstopfen und Kühkanalbohrungen

ISO 15488 B (DIN 6499 B) System ER

Collets with seals and cooling channels ISO 15488 B (DIN 6499 B) ER-system
Pincés de serrage avec canaux d'arrosage ISO 15488 B (DIN 6499 B) système ER



Verwendung:
Zur Aufnahme von Werkzeugen mit Zylinderschaft in Spannfutter DIN 6499.

Application:
For mounting straight-shank tools in collet chucks DIN 6499.

Application:
Pour le serrage d'outils avec queue cylindrique dans mandrins à pincés DIN 6499.

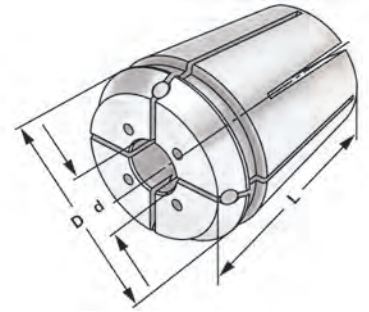

ISO 15488 B
DIN 6499 B

ER

$\nabla \leq 0,015$



Bestell-Nr. Order no. Référence	Größe Size Taille	d	D	L
470EC-03	ER 32	3	33	40
470EC-04	ER 32	4	33	40
470EC-05	ER 32	5	33	40
470EC-06	ER 32	6	33	40
470EC-07	ER 32	7	33	40
470EC-08	ER 32	8	33	40
470EC-09	ER 32	9	33	40
470EC-10	ER 32	10	33	40
470EC-11	ER 32	11	33	40
470EC-12	ER 32	12	33	40
470EC-13	ER 32	13	33	40
470EC-14	ER 32	14	33	40
470EC-15	ER 32	15	33	40
470EC-16	ER 32	16	33	40
470EC-17	ER 32	17	33	40
470EC-18	ER 32	18	33	40
470EC-19	ER 32	19	33	40
470EC-20	ER 32	20	33	40

9



Hinweis: Nur das Nennmaß d kann gespannt werden, mit Kühkanälen. Einsetzbar bis 21 bar. Um eine optimale Abdichtung zu erreichen, muss das zu spannende Werkzeug auf der ganzen Länge der geschliffenen Bohrung der Spannzange eingespannt werden.

Note: Only nominal size d can be clamped, with cooling channels. Applicable up to 21 bar. In order to achieve an optimum sealing the tool must be clamped on the complete length of the ground drill of the collet.

Observation: Seulement la dimension nominale d peut être tendu, avec canaux d'arrosage. Peut être utilisé jusqu'à 21 bar. Afin d'obtenir un étanchéité optimal l'outil doit être serré sur la longueur complète de l'alésage rectifié de la pince.



9.69



9.69



10.11

ISO 15488 B (DIN 6499 B) System ER

Collets with cooling channels along the boring ISO 15488 B (DIN 6499 B) ER-system

Pincettes de serrage avec canaux d'arrosage le long de l'alésage ISO 15488 B (DIN 6499 B) système ER



Verwendung:
Zur Aufnahme von Werkzeugen mit Zylinderschaft in Spannfutter DIN 6499.

Application:
For mounting straight-shank tools in collet chucks DIN 6499.

Application:
Pour le serrage d'outils avec queue cylindrique dans mandrins à pincettes DIN 6499.

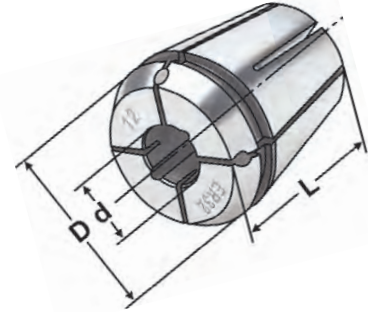

ISO 15488 B
DIN 6499 B

ER

$\lambda \leq 0,015$

14.04

Bestell-Nr. Order no. Référence	Größe Size Taille	d	D	L
470ECC-03	ER 32	3	33	40
470ECC-04	ER 32	4	33	40
470ECC-05	ER 32	5	33	40
470ECC-06	ER 32	6	33	40
470ECC-07	ER 32	7	33	40
470ECC-08	ER 32	8	33	40
470ECC-09	ER 32	9	33	40
470ECC-10	ER 32	10	33	40
470ECC-11	ER 32	11	33	40
470ECC-12	ER 32	12	33	40
470ECC-13	ER 32	13	33	40
470ECC-14	ER 32	14	33	40
470ECC-15	ER 32	15	33	40
470ECC-16	ER 32	16	33	40
470ECC-17	ER 32	17	33	40
470ECC-18	ER 32	18	33	40
470ECC-19	ER 32	19	33	40
470ECC-20	ER 32	20	33	40



Hinweis: Nur das Nennmaß d kann gespannt werden, mit Kühlkanälen entlang der Bohrung. Einsetzbar bis 21 bar. Um eine optimale Abdichtung zu erreichen, muss das zu spannende Werkzeug auf der ganzen Länge der geschliffenen Bohrung der Spannzange eingespannt werden.

Note: Only nominal size d can be clamped, with cooling channels along the boring. Applicable up to 21 bar. In order to achieve an optimum sealing the tool must be clamped on the complete length of the ground drill of the collet.

Observation: Seulement la dimension nominale d peut être tendu, avec canaux d'arrosage le long de l'alésage. Peut être utilisé jusqu'à 21 bar. Afin d'obtenir un étanchéité optimal l'outil doit être serré sur la longueur complète de l'alésage rectifié de la pince.





Präzisionsspannzangen ISO 15488 B (DIN 6499 B) System ER - Edelstahl

Precision collets ISO 15488 B (DIN 6499 B) ER-system - stainless steel

Pincettes de serrage de précision ISO 15488 B (DIN 6499 B) système ER - acier inoxydable



Verwendung:

Zur Aufnahme von Werkzeugen mit Zylinderschaft in Spannfutter DIN 6499. Für Anwendungen im HSC-Bereich und für hochpräzise Bearbeitungsergebnisse.

Application:

For mounting straight-shank tools in collet chucks DIN 6499. To use for high speed cutting and high precision milling.

Application:

Pour le serrage d'outils avec queue cylindrique dans mandrins à pincettes DIN 6499. Pour l'usage dans le coupage à grande vitesse et dans l'usinage à grande précision.

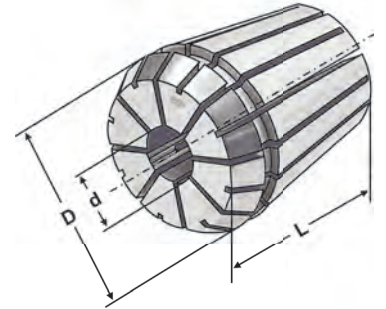

ISO 15488 B
DIN 6499 B

ER

$\lambda \leq 0,005$



Bestell-Nr. Order no. Référence	Größe Size Taille	d	D	L
470ESP-03	ER 32	3,0 - 2,5	33	40
470ESP-035	ER 32	3,5 - 3,0	33	40
470ESP-04	ER 32	4,0 - 3,5	33	40
470ESP-045	ER 32	4,5 - 4,0	33	40
470ESP-05	ER 32	5,0 - 4,5	33	40
470ESP-055	ER 32	5,5 - 5,0	33	40
470ESP-06	ER 32	6,0 - 5,5	33	40
470ESP-065	ER 32	6,5 - 6,0	33	40
470ESP-07	ER 32	7,0 - 6,5	33	40
470ESP-075	ER 32	7,5 - 7,0	33	40
470ESP-08	ER 32	8,0 - 7,5	33	40
470ESP-085	ER 32	8,5 - 8,0	33	40
470ESP-09	ER 32	9,0 - 8,5	33	40
470ESP-095	ER 32	9,5 - 9,0	33	40
470ESP-10	ER 32	10,0 - 9,5	33	40
470ESP-105	ER 32	10,5 - 10,0	33	40
470ESP-11	ER 32	11,0 - 10,5	33	40
470ESP-115	ER 32	11,5 - 11,0	33	40
470ESP-12	ER 32	12,0 - 11,5	33	40
470ESP-125	ER 32	12,5 - 12,0	33	40
470ESP-13	ER 32	13,0 - 12,5	33	40
470ESP-135	ER 32	13,5 - 13,0	33	40
470ESP-14	ER 32	14,0 - 13,5	33	40
470ESP-145	ER 32	14,5 - 14,0	33	40
470ESP-15	ER 32	15,0 - 14,5	33	40
470ESP-155	ER 32	15,5 - 15,0	33	40
470ESP-16	ER 32	16,0 - 15,5	33	40
470ESP-165	ER 32	16,5 - 16,0	33	40
470ESP-17	ER 32	17,0 - 16,5	33	40
470ESP-175	ER 32	17,5 - 17,0	33	40
470ESP-18	ER 32	18,0 - 17,5	33	40
470ESP-185	ER 32	18,5 - 18,0	33	40
470ESP-19	ER 32	19,0 - 18,5	33	40
470ESP-195	ER 32	19,5 - 19,0	33	40
470ESP-20	ER 32	20,0 - 19,5	33	40

9



9.71



9.71



10.11

Tap collets - ISO 15488 B (DIN 6499 B) System ER

Pinces de serrage pour tarauds - ISO 15488 B (DIN 6499 B) System ER



Verwendung:
Für Maschinen mit steigungssynchronem Vorschub. Zur verkehrsicheren Spannung von Gewindebohrern.

Application:
For machines with rigid tapping.
For safe clamping of taps.

Application:
Pour machines avec broche synchronisée.
Pour le serrage stable de tarauds.

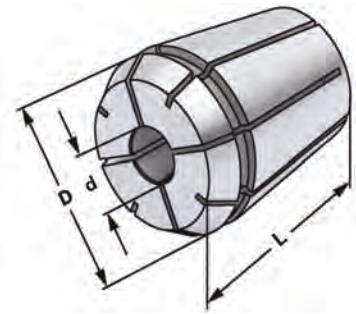

ISO 15488 B
DIN 6499 B

ER

$\lambda \leq 0,015$

14.04

Bestell-Nr. Order no. Référence	Größe Size Taille	Schaft Shaft Queue d	Vierkant Square Carré	D	L
470G-4534	ER 32	4,5	3,4	33	40
470G-649	ER 32	6	4,9	33	40
470G-755	ER 32	7	5,5	33	40
470G-862	ER 32	8	6,2	33	40
470G-97	ER 32	9	7	33	40
470G-108	ER 32	10	8	33	40
470G-119	ER 32	11	9	33	40
470G-129	ER 32	12	9	33	40
470G-1411	ER 32	14	11	33	40
470G-1612	ER 32	16	12	33	40





Gewindebohrer Spannzangen mit Kühkanalbohrungen

Tap collets with cooling channels
Pincettes de serrage avec canaux d'arrosage



Verwendung:
Für Maschinen mit steigungssynchronem Vorschub. Zur verdrehensicheren Spannung von Gewindebohrern.

Application:
For machines with rigid tapping.
For safe clamping of taps.

Application:
Pour machines avec broche synchronisée.
Pour le serrage stable de tarauds.

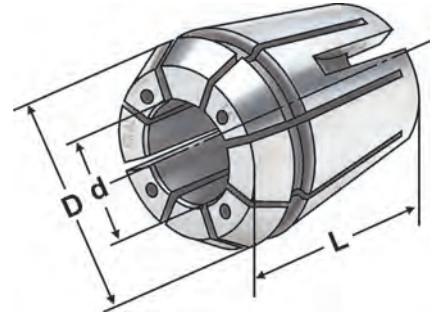

ISO 15488 B
DIN 6499 B

ER

$\nabla \leq 0,015$



Bestell-Nr. Order no. Référence	Größe Size Taille	Schaft Shaft Queue	Vierkant Square Carré	D	L
470GC-4534	ER 32	4,5	3,4	32,8	40
470GC-649	ER 32	6	4,9	32,8	40
470GC-755	ER 32	7	5,5	32,8	40
470GC-862	ER 32	8	6,2	32,8	40
470GC-97	ER 32	9	7	32,8	40
470GC-108	ER 32	10	8	32,8	40
470GC-119	ER 32	11	9	32,8	40
470GC-129	ER 32	12	9	32,8	40
470GC-1411	ER 32	14	11	32,8	40
470GC-1612	ER 32	16	12	32,8	40



9.73



9.73



10.11

Tap collets with seals
Pincettes de serrage pour tarauds



Verwendung:
Für Maschinen mit steigungssynchronem Vorschub. Zur verdrehsicheren Spannung von Gewindebohrern.

Application:
For machines with rigid tapping. For safe clamping of taps.

Application:
Pour machines avec broche synchronisée. Pour le serrage stable de tarauds.

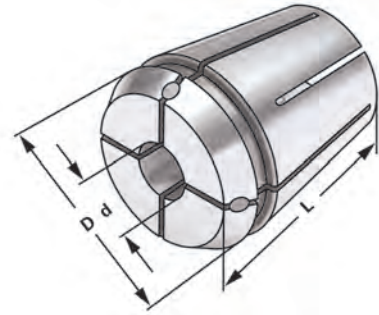

ISO 15488 B
DIN 6499 B

ER

$\nabla \leq 0,015$

14.04

Bestell-Nr. Order no. Référence	Größe Size Taille	Schaft Shaft Queue	Vierkant Square Carré	D	L
470GA-4534	ER 32	4,5	3,4	32,8	40
470GA-649	ER 32	6	4,9	32,8	40
470GA-755	ER 32	7	5,5	32,8	40
470GA-862	ER 32	8	6,2	32,8	40
470GA-97	ER 32	9	7	32,8	40
470GA-108	ER 32	10	8	32,8	40
470GA-119	ER 32	11	9	32,8	40
470GA-129	ER 32	12	9	32,8	40
470GA-1411	ER 32	14	11	32,8	40
470GA-1612	ER 32	16	12	32,8	40

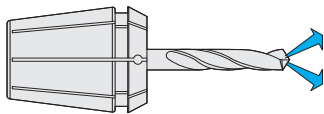



Spannzangen ISO 15488 B (DIN 6499 B) System ER

Collets ISO 15488 B (DIN 6499 B) ER-system

Pinces de serrage ISO 15488 B (DIN 6499 B) système ER



Verwendung:

Zur Aufnahme von Werkzeugen mit Zylinderschaft in Spannfutter DIN 6499.

Application:

For mounting straight-shank tools in collet chucks DIN 6499.

Application:

Pour le serrage d'outils avec queue cylindrique dans mandrins à pinces DIN 6499.

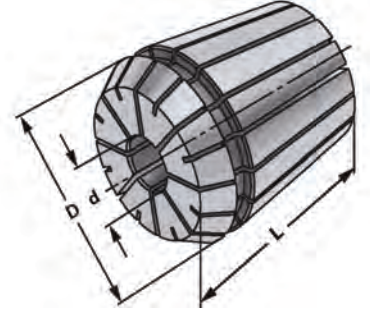

ISO 15488 B
DIN 6499 B

ER

$\lambda \leq 0,015$



Bestell-Nr. Order no. Référence	Größe Size Taille	d	D	L
472E-03	ER 40	3 - 2,5	41	46
472E-04	ER 40	4 - 3,0	41	46
472E-05	ER 40	5 - 4,0	41	46
472E-06	ER 40	6 - 5,0	41	46
472E-07	ER 40	7 - 6,0	41	46
472E-08	ER 40	8 - 7,0	41	46
472E-09	ER 40	9 - 8,0	41	46
472E-10	ER 40	10 - 9,0	41	46
472E-11	ER 40	11 - 10,0	41	46
472E-12	ER 40	12 - 11,0	41	46
472E-13	ER 40	13 - 12,0	41	46
472E-14	ER 40	14 - 13,0	41	46
472E-15	ER 40	15 - 14,0	41	46
472E-16	ER 40	16 - 15,0	41	46
472E-17	ER 40	17 - 16,0	41	46
472E-18	ER 40	18 - 17,0	41	46
472E-19	ER 40	19 - 18,0	41	46
472E-20	ER 40	20 - 19,0	41	46
472E-21	ER 40	21 - 20,0	41	46
472E-22	ER 40	22 - 21,0	41	46
472E-23	ER 40	23 - 22,0	41	46
472E-24	ER 40	24 - 23,0	41	46
472E-25	ER 40	25 - 24,0	41	46
472E-26	ER 40	26 - 25,0	41	46

Hinweis: Hohe Flexibilität: Großer Spannbereich bis -1 mm
Note: High flexibility: Large holding capacity up to -1 mm
Observation: Grande capacité de serrage jusqu'à -1 mm



Precision collets ISO 15488 B (DIN 6499 B) ER-system

Pinces de serrage de précision ISO 15488 B (DIN 6499 B) système ER

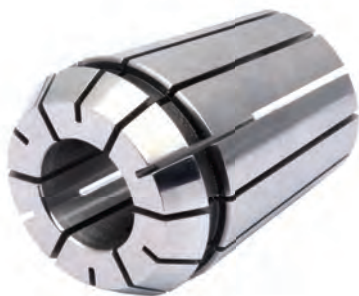

Verwendung:

Zur Aufnahme von Werkzeugen mit Zylinderschaft in Spannfutter DIN 6499. Für Anwendungen im HSC-Bereich und für hochpräzise Bearbeitungsergebnisse.

Application:

For mounting straight-shank tools in collet chucks DIN 6499. To use for high speed cutting and high precision milling.

Application:

Pour le serrage d'outils avec queue cylindrique dans mandrins à pinces DIN 6499. Pour l'usage dans le coupage à grande vitesse et dans l'usinage à grande précision.

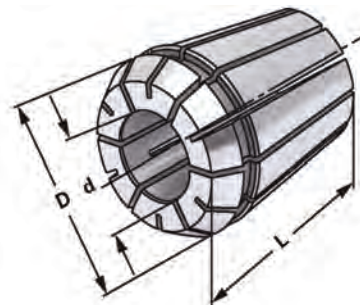

ISO 15488 B
DIN 6499 B

ER

$\lambda \leq 0,005$

14.04

Bestell-Nr. Order no. Référence	Größe Size Taille	d	D	L
472EP-03	ER 40	3 - 2,5	41	46
472EP-04	ER 40	4 - 3,0	41	46
472EP-05	ER 40	5 - 4,0	41	46
472EP-06	ER 40	6 - 5,0	41	46
472EP-07	ER 40	7 - 6,0	41	46
472EP-08	ER 40	8 - 7,0	41	46
472EP-09	ER 40	9 - 8,0	41	46
472EP-10	ER 40	10 - 9,0	41	46
472EP-11	ER 40	11 - 10,0	41	46
472EP-12	ER 40	12 - 11,0	41	46
472EP-13	ER 40	13 - 12,0	41	46
472EP-14	ER 40	14 - 13,0	41	46
472EP-15	ER 40	15 - 14,0	41	46
472EP-16	ER 40	16 - 15,0	41	46
472EP-17	ER 40	17 - 16,0	41	46
472EP-18	ER 40	18 - 17,0	41	46
472EP-19	ER 40	19 - 18,0	41	46
472EP-20	ER 40	20 - 19,0	41	46
472EP-21	ER 40	21 - 20,0	41	46
472EP-22	ER 40	22 - 21,0	41	46
472EP-23	ER 40	23 - 22,0	41	46
472EP-24	ER 40	24 - 23,0	41	46
472EP-25	ER 40	25 - 24,0	41	46
472EP-26	ER 40	26 - 25,0	41	46

Hinweis: Hohe Flexibilität: Großer Spannbereich bis -1 mm
Note: High flexibility: Large holding capacity up to -1 mm
Observation: Grande capacité de serrage jusqu'à -1 mm





Spannzangen mit Abdichtung für IK - ISO 15488 B (DIN 6499 B) System ER

Collets sealed for IC - ISO 15488 B (DIN 6499 B) ER-system

Pinces de serrage avec joint d'étanchéité pour IC - ISO 15488 B (DIN 6499 B) système ER



Verwendung:

Zur Aufnahme von Werkzeugen mit Innenkühlung und Zylinderschaft in Spannfutter DIN 6499

Application:

For mounting straight-shank tools with internal cooling in collet chucks DIN 6499

Application:

Pour le serrage des outils avec le refroidissement interne et avec queue cylindrique dans mandrins à pinces DIN 6499

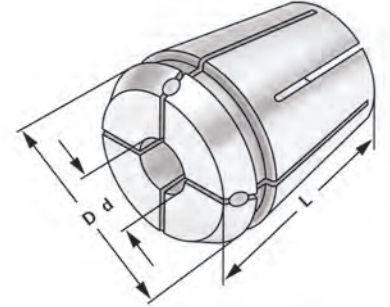

ISO 15488 B
DIN 6499 B

ER

$\nabla \leq 0,015$



Bestell-Nr. Order no. Référence	Größe Size Taille	d	D	L
472EA-03	ER 40	3	41	46
472EA-04	ER 40	4	41	46
472EA-05	ER 40	5	41	46
472EA-06	ER 40	6	41	46
472EA-07	ER 40	7	41	46
472EA-08	ER 40	8	41	46
472EA-09	ER 40	9	41	46
472EA-10	ER 40	10	41	46
472EA-11	ER 40	11	41	46
472EA-12	ER 40	12	41	46
472EA-13	ER 40	13	41	46
472EA-14	ER 40	14	41	46
472EA-15	ER 40	15	41	46
472EA-16	ER 40	16	41	46
472EA-17	ER 40	17	41	46
472EA-18	ER 40	18	41	46
472EA-19	ER 40	19	41	46
472EA-20	ER 40	20	41	46
472EA-21	ER 40	21	41	46
472EA-22	ER 40	22	41	46
472EA-23	ER 40	23	41	46
472EA-24	ER 40	24	41	46
472EA-25	ER 40	25	41	46
472EA-26	ER 40	26	41	46

9

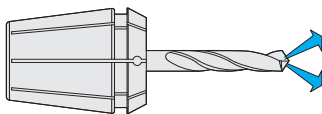

Hinweis:

Nur das Nennmaß d kann gespannt werden, mit Dichtstopfen für Innenkühlung (einsetzbar bis 21 bar). Um eine optimale Abdichtung zu erreichen, muss das zu spannende Werkzeug auf der ganzen Länge der geschliffenen Bohrung der Spannzange eingespannt werden.

Note:

Only nominal size d can be clamped with sealing plug for internal cooling (applicable up to 21 bar). In order to achieve an optimum sealing the tool must be clamped on the complete length of the ground drill of the collet.

Observation:

Seulement la dimension nominale d peut être tendu avec des bouchons 'étanchéité pour le refroidissement interne (peut être utilisé jusqu'à 21 bar). Afin d'obtenir un étanchéité optimal l'outil doit être serré sur la longueur complète de l'alésage rectifié de la pince.



9.67



9.67



10.11

Collets steel sealed for high pressure cooling until 120 bar
 Pincettes de serrage, étanche pour arrosage de haute pression 120 bar



Verwendung:
 Zur Aufnahme von Werkzeugen mit Innenkühlung und Zylinderschaft in Spannfutter DIN 6499

Application:
 For mounting straight-shank tools with internal cooling in collet chucks DIN 6499

Application:
 Pour le serrage des outils avec le refroidissement interne et avec queue cylindrique dans mandrins à pincettes DIN 6499

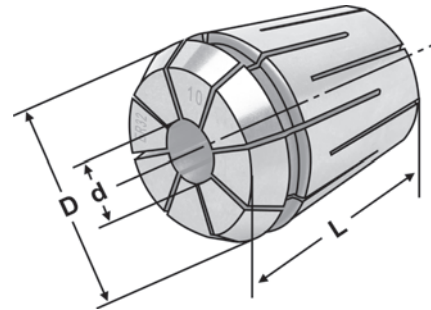

ISO 15488 B
 DIN 6499 B

ER

$\nabla \leq 0,015$

14.04

Bestell-Nr. Order no. Référence	Größe Size Taille	d	D	L
472EH-04	ER 40	4	41	46
472EH-05	ER 40	5	41	46
472EH-06	ER 40	6	41	46
472EH-07	ER 40	7	41	46
472EH-08	ER 40	8	41	46
472EH-09	ER 40	9	41	46
472EH-10	ER 40	10	41	46
472EH-11	ER 40	11	41	46
472EH-12	ER 40	12	41	46
472EH-13	ER 40	13	41	46
472EH-14	ER 40	14	41	46
472EH-15	ER 40	15	41	46
472EH-16	ER 40	16	41	46
472EH-17	ER 40	17	41	46
472EH-18	ER 40	18	41	46
472EH-19	ER 40	19	41	46
472EH-20	ER 40	20	41	46
472EH-21	ER 40	21	41	46
472EH-22	ER 40	22	41	46
472EH-23	ER 40	23	41	46
472EH-24	ER 40	24	41	46
472EH-25	ER 40	25	41	46
472EH-26	ER 40	26	41	46

9

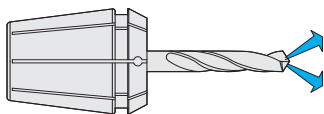

Hinweis: Nur das Nennmaß d kann gespannt werden (einsetzbar bis 120 bar). Um eine optimale Abdichtung zu erreichen, muss das zu spannende Werkzeug auf der ganzen Länge der geschliffenen Bohrung der Spannzange eingespannt werden.

Note: Only nominal size d can be clamped (applicable up to 120 bar). In order to achieve an optimum sealing the tool must be clamped on the complete length of the ground drill of the collet.

Observation: Seulement la dimension nominale d peut être tendu (peut être utilisé jusqu'à 120 bar). Afin d'obtenir un étanchéité optimal l'outil doit être serré sur la longueur complète de l'alésage rectifié de la pince.





Spannzangen mit Kühlkanalbohrungen ISO 15488 B (DIN 6499 B) System ER

Collets with cooling channels ISO 15488 B (DIN 6499 B) ER-system

Pinces de serrage avec canaux d'arrosage ISO 15488 B (DIN 6499 B) système ER



Verwendung:

Zur Aufnahme von Werkzeugen mit Zylinderschaft in Spannfutter DIN 6499.

Application:

For mounting straight-shank tools in collet chucks DIN 6499.

Application:

Pour le serrage d'outils avec queue cylindrique dans mandrins à pinces DIN 6499.

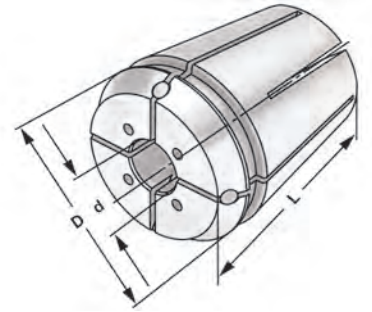

ISO 15488 B
DIN 6499 B

ER

$\lambda \leq 0,015$



Bestell-Nr. Order no. Référence	Größe Size Taille	d	D	L
472EC-04	ER 40	4	41	46
472EC-05	ER 40	5	41	46
472EC-06	ER 40	6	41	46
472EC-07	ER 40	7	41	46
472EC-08	ER 40	8	41	46
472EC-09	ER 40	9	41	46
472EC-10	ER 40	10	41	46
472EC-11	ER 40	11	41	46
472EC-12	ER 40	12	41	46
472EC-13	ER 40	13	41	46
472EC-14	ER 40	14	41	46
472EC-15	ER 40	15	41	46
472EC-16	ER 40	16	41	46
472EC-17	ER 40	17	41	46
472EC-18	ER 40	18	41	46
472EC-19	ER 40	19	41	46
472EC-20	ER 40	20	41	46
472EC-21	ER 40	21	41	46
472EC-22	ER 40	22	41	46
472EC-23	ER 40	23	41	46
472EC-24	ER 40	24	41	46
472EC-25	ER 40	25	41	46
472EC-26	ER 40	26	41	46



Hinweis:

Nur das Nennmaß d kann gespannt werden, mit Kühlkanälen. Einsetzbar bis 21 bar. Um eine optimale Abdichtung zu erreichen, muss das zu spannende Werkzeug auf der ganzen Länge der geschliffenen Bohrung der Spannzange eingespannt werden.

Note:

Only nominal size d can be clamped, with cooling channels. Applicable up to 21 bar. In order to achieve an optimum sealing the tool must be clamped on the complete length of the ground drill of the collet.

Observation:

Seulement la dimension nominale d peut être tendu, avec canaux d'arrosage. Peut être utilisé jusqu'à 21 bar. Afin d'obtenir un étanchéité optimal l'outil doit être serré sur la longueur complète de l'alésage rectifié de la pince.

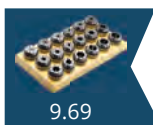

9.69



9.69



10.11

ISO 15488 B (DIN 6499 B) System ER

Collets with cooling channels along the boring ISO 15488 B (DIN 6499 B) ER-system

Pincettes de serrage avec canaux d'arrosage le long de l'alésage ISO 15488 B (DIN 6499 B) système ER



Verwendung:
Zur Aufnahme von Werkzeugen mit Zylinderschaft in Spannfutter DIN 6499.

Application:
For mounting straight-shank tools in collet chucks DIN 6499.

Application:
Pour le serrage d'outils avec queue cylindrique dans mandrins à pincettes DIN 6499.

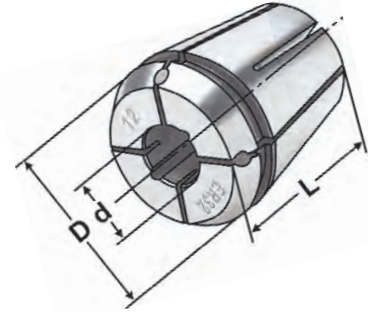

ISO 15488 B
DIN 6499 B

ER

$\lambda \leq 0,015$

14.04

Bestell-Nr. Order no. Référence	Größe Size Taille	d	D	L
472ECC-04	ER 40	4	41	46
472ECC-05	ER 40	5	41	46
472ECC-06	ER 40	6	41	46
472ECC-07	ER 40	7	41	46
472ECC-08	ER 40	8	41	46
472ECC-09	ER 40	9	41	46
472ECC-10	ER 40	10	41	46
472ECC-11	ER 40	11	41	46
472ECC-12	ER 40	12	41	46
472ECC-13	ER 40	13	41	46
472ECC-14	ER 40	14	41	46
472ECC-15	ER 40	15	41	46
472ECC-16	ER 40	16	41	46
472ECC-17	ER 40	17	41	46
472ECC-18	ER 40	18	41	46
472ECC-19	ER 40	19	41	46
472ECC-20	ER 40	20	41	46
472ECC-21	ER 40	21	41	46
472ECC-22	ER 40	22	41	46
472ECC-23	ER 40	23	41	46
472ECC-24	ER 40	24	41	46
472ECC-25	ER 40	25	41	46
472ECC-26	ER 40	26	41	46



Hinweis: Nur das Nennmaß d kann gespannt werden, mit Kühlkanälen entlang der Bohrung. Einsetzbar bis 21 bar. Um eine optimale Abdichtung zu erreichen, muss das zu spannende Werkzeug auf der ganzen Länge der geschliffenen Bohrung der Spannzange eingespannt werden.

Note: Only nominal size d can be clamped, with cooling channels along the boring. Applicable up to 21 bar. In order to achieve an optimum sealing the tool must be clamped on the complete length of the ground drill of the collet.

Observation: Seulement la dimension nominale d peut être tendu, avec canaux d'arrosage le long de l'alésage. Peut être utilisé jusqu'à 21 bar. Afin d'obtenir un étanchéité optimal l'outil doit être serré sur la longueur complète de l'alésage rectifié de la pince.





Gewindebohrer Spannzangen - ISO 15488 B (DIN 6499 B) System ER

Tap collets - ISO 15488 B (DIN 6499 B) System ER

Pinces de serrage pour tarauds - ISO 15488 B (DIN 6499 B) System ER



Verwendung:

Für Maschinen mit steigungssynchronem Vorschub. Zur verdrehsicheren Spannung von Gewindebohrern.

Application:

For machines with rigid tapping. For safe clamping of taps.

Application:

Pour machines avec broche synchronisée. Pour le serrage stable de tarauds.

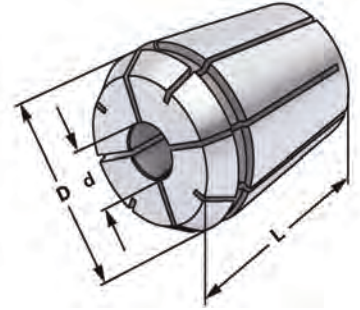

ISO 15488 B
DIN 6499 B

ER

$\nabla \leq 0,015$



Bestell-Nr. Order no. Référence	Größe Size Taille	Schaft Shaft Queue	Vierkant Square Carré	D	L
472G-649	ER 40	6	4,9	40,8	46
472G-755	ER 40	7	5,5	40,8	46
472G-862	ER 40	8	6,2	40,8	46
472G-97	ER 40	9	7	40,8	46
472G-108	ER 40	10	8	40,8	46
472G-119	ER 40	11	9	40,8	46
472G-129	ER 40	12	9	40,8	46
472G-1411	ER 40	14	11	40,8	46
472G-1612	ER 40	16	12	40,8	46
472G-18145	ER 40	18	14,5	40,8	46
472G-2016	ER 40	20	16	40,8	46



Tap collets with cooling channels
Pincettes de serrage avec canaux d'arrosage



Verwendung:
Für Maschinen mit steigungssynchronem Vorschub. Zur verdrehsicheren Spannung von Gewindebohrern.

Application:
For machines with rigid tapping. For safe clamping of taps.

Application:
Pour machines avec broche synchronisée. Pour le serrage stable de tarauds.

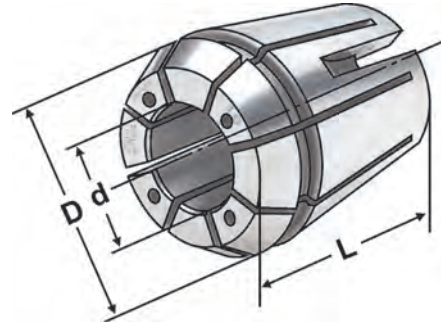

ISO 15488 B
DIN 6499 B

ER

$\nabla \leq 0,015$

14.04

Bestell-Nr. Order no. Référence	Größe Size Taille	d	Schaft Shaft Queue	Vierkant Square Carré	D	L
472GC-649	ER 40	6		4,9	40,8	46
472GC-755	ER 40	7		5,5	40,8	46
472GC-862	ER 40	8		6,2	40,8	46
472GC-97	ER 40	9		7	40,8	46
472GC-108	ER 40	10		8	40,8	46
472GC-119	ER 40	11		9	40,8	46
472GC-129	ER 40	12		9	40,8	46
472GC-1411	ER 40	14		11	40,8	46
472GC-1612	ER 40	16		12	40,8	46
472GC-18145	ER 40	18		14,5	40,8	46
472GC-2016	ER 40	20		16	40,8	46





Gewindebohrer Spannzangen mit Dichtstopfen

Tap collets with seals
Pincés de serrage pour tarauds



Verwendung:
Für Maschinen mit steigungssynchronem Vorschub. Zur verdrehensicheren Spannung von Gewindebohrern.

Application:
For machines with rigid tapping. For safe clamping of taps.

Application:
Pour machines avec broche synchronisée. Pour le serrage stable de tarauds.

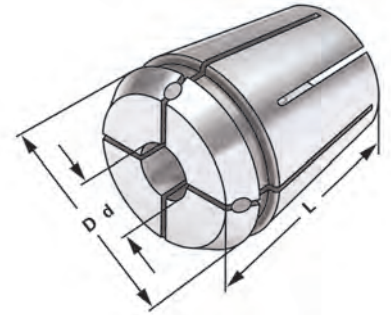

ISO 15488 B
DIN 6499 B

ER

$\nabla \leq 0,015$



Bestell-Nr. Order no. Référence	Größe Size Taille	Schaft Shaft Queue	Vierkant Square Carré	D	L
472GA-649	ER 40	6	4,9	40,8	46
472GA-755	ER 40	7	5,5	40,8	46
472GA-862	ER 40	8	6,2	40,8	46
472GA-97	ER 40	9	7	40,8	46
472GA-108	ER 40	10	8	40,8	46
472GA-119	ER 40	11	9	40,8	46
472GA-129	ER 40	12	9	40,8	46
472GA-1411	ER 40	14	11	40,8	46
472GA-1612	ER 40	16	12	40,8	46
472GA-18145	ER 40	18	14,5	40,8	46
472GA-2016	ER 40	20	16	40,8	46

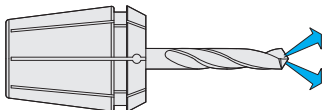

9.74



9.74













10.11



Technische Datenblätter, STEP/STL Modelle für die Simulation der NC-Programme und DXF-Zeichnungen zur Erstellung des Einrichteblattes stehen Online zur Verfügung.

Technical data sheets, STEP/STL models for the simulation of NC programs and DXF drawings to create the tooling sheet are online available.

Fiches techniques, STEP/STL modèles techniques pour la simulation de programmes CN et dessins DXF pour créer la feuille d'installation sont disponible online.

Bezeichnung Designation Désignation	E	EP	EA	EC	ECC	EH	ESP	G	GA	GC
										
Rundlauf Concentricity Concentricité	≤ 15 μ	≤ 5 μ	≤ 15 μ	≤ 15 μ	≤ 15 μ	≤ 15 μ	≤ 5 μ	≤ 15 μ	≤ 15 μ	≤ 15 μ
Spanndurchmesserüberbrückung Collapse Plage de serrage	0,5-1 mm	0,5-1 mm	h8	h8	h8	h8	h8	h8	h8	h8
Rostfrei Stainless Inoxydable	-	-	-	-	-	-	X	-	-	-
Abdichtung für IK (Innenkühlung) Sealing for IC (inner coolant supply) Avec joint d'étanchéité pour AC	-	-	X	-	-	X	-	-	X	-
Kühlkanalbohrung für IK (Innenkühlung) Jet holes for Inner Coolant Supply Avec canaux d'arrosage au centre	-	-	-	X	X	-	-	-	-	X
Innenvierkant für Gewindebohrer For tapping with internal square drive Pour taraudage avec carré d'entraînement	-	-	-	-	-	-	-	X	X	X



Spannzangensätze im Holzsockel ≤ 0,015

Collet sets in wooden sockets ≤ 0,015

Jeux de pinces dans socles en bois ≤ 0,015

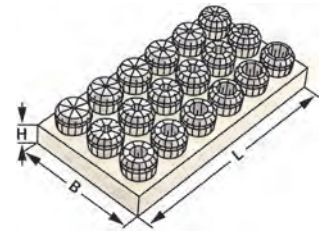

↗ ≤ 0,015



Bestell-Nr. Order no. Référence	Abmessung Size Dimension	L	B	H
415E - S	415E (OZ 16; 15 tlg.) 2-3-4-5-6-7-8-9-10-11-12-13-14-15-16	150	195	25
462E - S	462E (OZ 25; 15 tlg.) 4-5-6-7-8-9-10-11-12-14-16-18-20-22-25	290	240	30
467E - S	467E (OZ 32; 16 tlg.) 5-6-7-8-10-12-14-16-18-20-22-24-25-28-30-32	290	240	30
4008E - S	4008E (ER 11; 13 tlg.) 1-1,5-2-2,5-3-3,5-4-4,5-5-5,5-6-6,5-7	125	45	20
426E - S	426E (ER 16; 10 tlg.) 1-2-3-4-5-6-7-8-9-10	130	50	25
428E - S	428E (ER 20; 12 tlg.) 2-3-4-5-6-7-8-9-10-11-12-13	165	110	25
430E - S	430E (ER 25; 15 tlg.) 2-3-4-5-6-7-8-9-10-11-12-13-14-15-16	150	195	25
470E - S	470E (ER 32; 18 tlg.) 3-4-5-6-7-8-9-10-11-12-13-14-15-16-17-18-19-20	190	150	30
472E - S	472E (ER 40; 23 tlg.) 4-5-6-7-8-9-10-11-12-13-14-15-16-17-18-19-20-21-22-23-24-25-26	290	195	25

Spannzangensätze im Holzkasten ≤ 0,015

Collet sets in wooden boxes ≤ 0,015

Jeux de pinces dans coffrets en bois ≤ 0,015

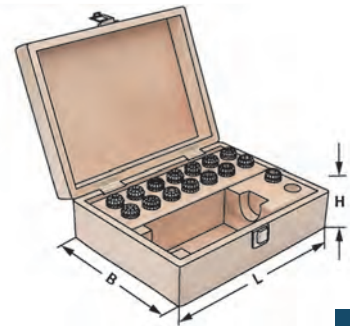

↗ ≤ 0,015



Bestell-Nr. Order no. Référence	Abmessung Size Dimension	L	B	H
701.415.1	415E (OZ 16; 15 St.) 2-3-4-5-6-7-8-9-10-11-12-13-14-15-16	360	235	70
701.462.1	462E (OZ 25; 15 St.) 4-5-6-7-8-9-10-11-12-14-16-18-20-22-25	360	235	70
701.467.1	467E (OZ 32; 16 St.) 5-6-7-8-10-12-14-16-18-20-22-24-25-28-30-32	360	235	70
701.4008.1	4008E (ER 11; 13 tlg.) 1-1,5-2-2,5-3-3,5-4-4,5-5-5,5-6-6,5-7	360	235	70
701.426.1	426E (ER 16; 10 St.) 1-2-3-4-5-6-7-8-9-10	360	235	70
701.428.1	428E (ER 20; 12 tlg.) 2-3-4-5-6-7-8-9-10-11-12-13	360	235	70
701.430.1	430E (ER 25; 15 St.) 2-3-4-5-6-7-8-9-10-11-12-13-14-15-16	360	235	70
701.470.1	470E (ER 32; 15 St.) 3-4-5-6-7-8-9-10-11-12-14-15-16-18-20	360	235	70
701.472.1	472E (ER 40; 16 St.) 4-5-6-7-8-9-10-11-12-14-16-18-20-22-24-26	360	235	70

OZ 16



9.05

OZ 25



9.07

OZ 32



9.09

ER 11



9.11

ER 16



9.15

ER 20



9.25

ER 25



9.35

ER 32



9.45

ER 40



9.55

Präzisionsspannzangensätze im Holzsockel ≤ 0,005 UP



Precision collet sets in wooden sockets ≤ 0,005 UP

Jeux de pinces de précision dans socles en bois ≤ 0,005 UP

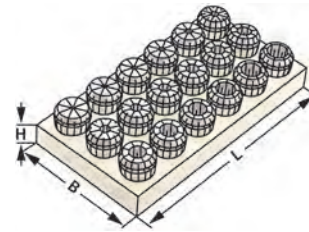

↗ ≤ 0,005



Bestell-Nr. Order no. Référence	Abmessung Size Dimension	L	B	H
415EP - S	415E (OZ 16; 15 tlg.) 2-3-4-5-6-7-8-9-10-11-12-13-14-15-16	150	195	25
462EP - S	462E (OZ 25; 15 tlg.) 4-5-6-7-8-9-10-11-12-14-16-18-20-22-25	290	240	30
467EP - S	467E (OZ 32; 16 tlg.) 5-6-7-8-10-12-14-16-18-20-22-24-25-28-30-32	290	240	30
4004EP - S	4004E (ER 8; 9 tlg.) 1-1,5-2-2,5-3-3,5-4-4,5-5	95	85	20
4008EP - S	4008E (ER 11; 13 tlg.) 1-1,5-2-2,5-3-3,5-4-4,5-5-5,5-6-6,5-7	95	85	20
426EP - S	426E (ER 16; 10 tlg.) 1-2-3-4-5-6-7-8-9-10	130	50	25
428EP - S	428E (ER 20; 12 tlg.) 2-3-4-5-6-7-8-9-10-11-12-13	165	110	25
430EP - S	430E (ER 25; 15 tlg.) 2-3-4-5-6-7-8-9-10-11-12-13-14-15-16	150	195	25
470EP - S	470E (ER 32; 18 tlg.) 3-4-5-6-7-8-9-10-11-12-13-14-15-16-17-18-19-20	190	150	30
472EP - S	472E (ER 40; 23 tlg.) 4-5-6-7-8-9-10-11-12-13-14-15-16-17-18-19-20-21-22-23-24-25-26	290	195	25

Präzisionsspannzangensätze im Holzkasten ≤ 0,005 UP

Precision collet sets in wooden boxes ≤ 0,005 UP

Jeux de pinces de précision dans coffrets en bois ≤ 0,005 UP



↗ ≤ 0,005



Bestell-Nr. Order no. Référence	Abmessung Size Dimension	L	B	H
701.415P.1	415E (OZ 16; 15 St.) 2-3-4-5-6-7-8-9-10-11-12-13-14-15-16	360	235	70
701.462P.1	462E (OZ 25; 15 St.) 4-5-6-7-8-9-10-11-12-14-16-18-20-22-25	360	235	70
701.467P.1	467E (OZ 32; 16 St.) 5-6-7-8-10-12-14-16-18-20-22-24-25-28-30-32	360	235	70
701.4008P.1	4008E (ER 11; 13 tlg.) 1-1,5-2-2,5-3-3,5-4-4,5-5-5,5-6-6,5-7	360	235	70
701.426P.1	426E (ER 16; 10 St.) 1-2-3-4-5-6-7-8-9-10	360	235	70
701.428P.1	428E (ER 20; 12 tlg.) 2-3-4-5-6-7-8-9-10-11-12-13	360	235	70
701.430P.1	430E (ER 25; 15 St.) 2-3-4-5-6-7-8-9-10-11-12-13-14-15-16	360	235	70
701.470P.1	470E (ER 32; 15 St.) 3-4-5-6-7-8-9-10-11-12-14-15-16-18-20	360	235	70
701.472P.1	472E (ER 40; 16 St.) 4-5-6-7-8-9-10-11-12-14-16-18-20-22-24-26	360	235	70





Spannzangen mit Abdichtung für IK - ISO 15488 B (DIN 6499 B) System ER

Collets with seal for IC - ISO 15488 B (DIN 6499 B) ER-system

Pinces de serrage avec joint d'étanchéité pour IC - ISO 15488 B (DIN 6499 B) système ER

Spannzangensätze im Holzsockel

Collet sets in wooden sockets

Jeux de pinces dans socles en bois

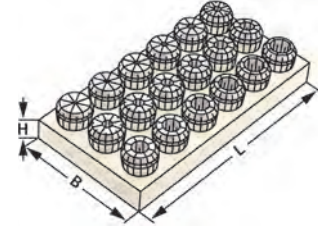

$\nabla \leq 0,015$



Bestell-Nr. Order no. Référence	Abmessung Size Dimension	L	B	H
426EA-S	426E (ER 16; 8 St.) 3-4-5-6-7-8-9-10	130	50	25
428EA-S	428E (ER 20; 11 St.) 3-4-5-6-7-8-9-10-11-12-13	165	110	25
430EA-S	430E (ER 25; 14 St.) 3-4-5-6-7-8-9-10-11-12-13-14-15-16	150	195	25
470EA-S	470E (ER 32; 15 St.) 3-4-5-6-7-8-9-10-11-12-14-15-16-18-20	190	150	30
472EA-S	472E (ER 40; 16 St.) 4-5-6-7-8-9-10-11-12-14-16-18-20-22-24-26	290	195	25

Spannzangensätze im Holzkasten

Collet sets in wooden boxes

Jeux de pinces dans coffrets en bois



$\nabla \leq 0,015$



Bestell-Nr. Order no. Référence	Abmessung Size Dimension	L	B	H
701.426EA.1	426E (ER 16; 8 St.) 3-4-5-6-7-8-9-10	360	235	70
701.428EA.1	428E (ER 20; 11 St.) 3-4-5-6-7-8-9-10-11-12-13	360	235	70
701.430EA.1	430E (ER 25; 14 St.) 3-4-5-6-7-8-9-10-11-12-13-14-15-16	360	235	70
701.470EA.1	470E (ER 32; 15 St.) 3-4-5-6-7-8-9-10-11-12-14-15-16-18-20	360	235	70
701.472EA.1	472E (ER 40; 16 St.) 4-5-6-7-8-9-10-11-12-14-16-18-20-22-24-26	360	235	70

9



Spannzangen abgedichtet für Hochdruckkühlung bis 120 bar



Collets with seals for high pressure cooling until 120 bar

Pincettes de serrage, étanche pour arrosage de haute pression 120 bar

Spannzangensätze im Holzsockel

Collet sets in wooden sockets

Jeux de pincettes dans socles en bois

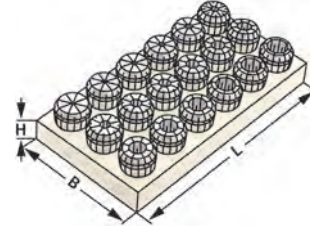

$\nabla \leq 0,015$



Bestell-Nr. Order no. Référence	Abmessung Size Dimension	L	B	H
426EH-S	426E (ER 16; 8 St.) 3-4-5-6-7-8-9-10	130	50	25
428EH-S	428E (ER 20; 11 St.) 3-4-5-6-7-8-9-10-11-12-13	165	110	25
430EH-S	430E (ER 25; 14 St.) 3-4-5-6-7-8-9-10-11-12-13-14-15-16	150	195	25
470EH-S	470E (ER 32; 15 St.) 3-4-5-6-7-8-9-10-11-12-14-15-16-18-20	190	150	30
472EH-S	472E (ER 40; 16 St.) 4-5-6-7-8-9-10-11-12-14-16-18-20-22-24-26	290	195	25

Spannzangensätze im Holzkasten

Collet sets in wooden boxes

Jeux de pincettes dans coffrets en bois



$\nabla \leq 0,015$



Bestell-Nr. Order no. Référence	Abmessung Size Dimension	L	B	H
701.426EH.1	426E (ER 16; 8 St.) 3-4-5-6-7-8-9-10	360	235	70
701.428EH.1	428E (ER 20; 11 St.) 3-4-5-6-7-8-9-10-11-12-13	360	235	70
701.430EH.1	430E (ER 25; 14 St.) 3-4-5-6-7-8-9-10-11-12-13-14-15-16	360	235	70
701.470EH.1	470E (ER 32; 15 St.) 3-4-5-6-7-8-9-10-11-12-14-15-16-18-20	360	235	70
701.472EH.1	472E (ER 40; 16 St.) 4-5-6-7-8-9-10-11-12-14-16-18-20-22-24-26	360	235	70

ER 16



9.18

ER 20



9.24

ER 25



9.38

ER 32



9.48

ER 40



9.58



Spannzangen mit Dichtstopfen und Kühkanalbohrungen

ISO 15488 B (DIN 6499 B) System ER

Collets with seals and cooling channels ISO 15488 B (DIN 6499 B) ER-system
Pincés de serrage avec canaux d'arrosage ISO 15488 B (DIN 6499 B) système ER

Spannzangensätze im Holzsockel

Collet sets in wooden sockets

Jeux de pincés dans socles en bois

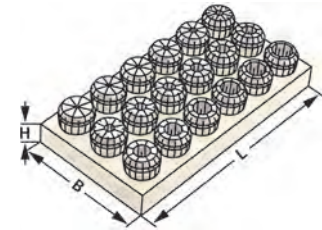

$\nabla \leq 0,015$



Bestell-Nr. Order no. Référence	Abmessung Size Dimension	L	B	H
426EC-S	426E (ER 16; 5 St.) 3-4-5-6-7	130	50	25
428EC-S	428E (ER 20; 6 St.) 4-5-6-7-8-9	165	110	25
430EC-S	430E (ER 25; 12 St.) 3-4-5-6-7-8-9-10-11-12-13-14	150	195	25
470EC-S	470E (ER 32; 15 St.) 3-4-5-6-7-8-9-10-11-12-14-15-16-18-20	190	150	30
472EC-S	472E (ER 40; 16 St.) 4-5-6-7-8-9-10-11-12-14-16-18-20-22-24-26	290	195	25

Spannzangensätze im Holzkasten

Collet sets in wooden boxes

Jeux de pincés dans coffrets en bois



$\nabla \leq 0,015$



Bestell-Nr. Order no. Référence	Abmessung Size Dimension	L	B	H
701.426EC.1	426E (ER 16; 5 St.) 3-4-5-6-7	360	235	70
701.428EC.1	428E (ER 20; 6 St.) 4-5-6-7-8-9	360	235	70
701.430EC.1	430E (ER 25; 12 St.) 3-4-5-6-7-8-9-10-11-12-13-14	360	235	70
701.470EC.1	470E (ER 32; 15 St.) 3-4-5-6-7-8-9-10-11-12-14-15-16-18-20	360	235	70
701.472EC.1	472E (ER 40; 16 St.) 4-5-6-7-8-9-10-11-12-14-16-18-20-22-24-26	360	235	70

ER 16



9.19

ER 20



9.29

ER 25



9.39

ER 32



9.49

ER 40



9.59

Spannzangen mit Kühlkanälen entlang der Bohrung



Collets with cooling channels along the boring ISO 15488 B (DIN 6499 B) ER-system

Pincettes de serrage avec canaux d'arrosage le long de l'alésage ISO 15488 B (DIN 6499 B) système ER

Spannzangensätze im Holzsockel

Collet sets in wooden sockets

Jeux de pincettes dans socles en bois

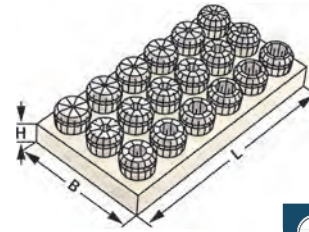

$\nabla \leq 0,015$

Bestell-Nr. Order no. Référence	Abmessung Size Dimension	L	B	H
426ECC-S	426E (ER 16; 5 St.) 3-4-5-6-7	130	50	25
428ECC-S	428E (ER 20; 6 St.) 4-5-6-7-8-9	165	110	25
430ECC-S	430E (ER 25; 12 St.) 3-4-5-6-7-8-9-10-11-12-13-14	150	195	25
470ECC-S	470E (ER 32; 15 St.) 3-4-5-6-7-8-9-10-11-12-14-15-16-18-20	190	150	30
472ECC-S	472E (ER 40; 16 St.) 4-5-6-7-8-9-10-11-12-14-16-18-20-22-24-26	290	195	25

Spannzangensätze im Holzkasten

Collet sets in wooden boxes

Jeux de pincettes dans coffrets en bois



$\nabla \leq 0,015$

Bestell-Nr. Order no. Référence	Abmessung Size Dimension	L	B	H
701.426ECC.1	426E (ER 16; 5 St.) 3-4-5-6-7	360	235	70
701.428ECC.1	428E (ER 20; 6 St.) 4-5-6-7-8-9	360	235	70
701.430ECC.1	430E (ER 25; 12 St.) 3-4-5-6-7-8-9-10-11-12-13-14	360	235	70
701.470ECC.1	470E (ER 32; 15 St.) 3-4-5-6-7-8-9-10-11-12-14-15-16-18-20	360	235	70
701.472ECC.1	472E (ER 40; 16 St.) 4-5-6-7-8-9-10-11-12-14-16-18-20-22-24-26	360	235	70





Präzisionsspannzangen ISO 15488 B (DIN 6499 B) System ER - Edelstahl

Precision collets ISO 15488 B (DIN 6499 B) ER-system - stainless steel

Pinces de serrage de précision ISO 15488 B (DIN 6499 B) système ER - acier inoxydable

Spannzangensätze im Holzsockel

Collet sets in wooden sockets

Jeux de pinces dans socles en bois

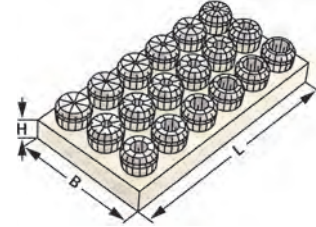

$\nabla \leq 0,015$



Bestell-Nr. Order no. Référence	Abmessung Size Dimension		L	B	H
4008ESP-S	4008E (ER 11; 5 St.)	3-4-5-6-7	130	50	25
426ESP-S	426E (ER 16; 8 St.)	3-4-5-6-7-8-9-10	165	110	25
428ESP-S	428E (ER 20; 11 St.)	3-4-5-6-7-8-9-10-11-12-13	150	195	25
430ESP-S	430E (ER 25; 14 St.)	3-4-5-6-7-8-9-10-11-12-13-14-15-16	190	150	30
470ESP-S	470E (ER 32; 18 St.)	3-4-5-6-7-8-9-10-11-12-13-14-15-16-17-18-19-20	290	195	25

Spannzangensätze im Holzkasten

Collet sets in wooden boxes

Jeux de pinces dans coffrets en bois



9

$\nabla \leq 0,015$



Bestell-Nr. Order no. Référence	Abmessung Size Dimension		L	B	H
701.4008ESP.1	4008E (ER 11; 5 St.)	3-4-5-6-7	360	235	70
701.426ESP.1	426E (ER 16; 8 St.)	3-4-5-6-7-8-9-10	360	235	70
701.428ESP.1	428E (ER 20; 11 St.)	3-4-5-6-7-8-9-10-11-12-13	360	235	70
701.430ESP.1	430E (ER 25; 14 St.)	3-4-5-6-7-8-9-10-11-12-13-14-15-16	360	235	70
701.470ESP.1	470E (ER 32; 18 St.)	3-4-5-6-7-8-9-10-11-12-13-14-15-16-17-18-19-20	360	235	70



Tap collets
Pincettes de serrage pour tarauds

Spannzangensätze im Holzsockel

Collet sets in wooden sockets
Jeux de pinces dans socles en bois

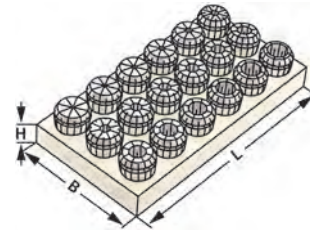

$\nabla \leq 0,015$

14.04

Bestell-Nr. Order no. Référence	Abmessung Size Dimension		L	B	H
426G-S	426E (ER 16; 6 St.)	3,5×2,7 - 4×3 - 4,5×3,4 - 6×4,9 - 7×5,5 - 8×6,2	130	50	25
428G-S	428E (ER 20; 8 St.)	3,5×2,7 - 4×3 - 4,5×3,4 - 6×4,9 - 7×5,5 - 8×6,2 - 9×7 - 10×8	165	110	25
430G-S	430E (ER 25; 10 St.)	3,5×2,7 - 4×3 - 4,5×3,4 - 6×4,9 - 7×5,5 - 8×6,2 - 9×7 - 10×8 - 11×9 - 12×9	150	195	25
470G-S	470E (ER 32; 10 St.)	4,5×3,4 - 6×4,9 - 7×5,5 - 8×6,2 - 9×7 - 10×8 - 11×9 - 12×9 - 14×11 - 16×12	190	150	30
472G-S	472E (ER 40; 11 St.)	6×4,9 - 7×5,5 - 8×6,2 - 9×7 - 10×8 - 11×9 - 12×9 - 14×11 - 16×12 - 18×14,5 - 20×16	290	195	25

Spannzangensätze im Holzkasten

Collet sets in wooden boxes
Jeux de pinces dans coffrets en bois



$\nabla \leq 0,015$

14.04

Bestell-Nr. Order no. Référence	Abmessung Size Dimension		L	B	H
701.426G.1	426E (ER 16; 6 St.)	3,5×2,7 - 4×3 - 4,5×3,4 - 6×4,9 - 7×5,5 - 8×6,2	360	235	70
701.428G.1	428E (ER 20; 8 St.)	3,5×2,7 - 4×3 - 4,5×3,4 - 6×4,9 - 7×5,5 - 8×6,2 - 9×7 - 10×8	360	235	70
701.430G.1	430E (ER 25; 10 St.)	3,5×2,7 - 4×3 - 4,5×3,4 - 6×4,9 - 7×5,5 - 8×6,2 - 9×7 - 10×8 - 11×9 - 12×9	360	235	70
701.470G.1	470E (ER 32; 10 St.)	4,5×3,4 - 6×4,9 - 7×5,5 - 8×6,2 - 9×7 - 10×8 - 11×9 - 12×9 - 14×11 - 16×12	360	235	70
701.472G.1	472E (ER 40; 11 St.)	6×4,9 - 7×5,5 - 8×6,2 - 9×7 - 10×8 - 11×9 - 12×9 - 14×11 - 16×12 - 18×14,5 - 20×16	360	235	70





Gewindebohrer Spannzangen mit Dichtstopfen und Kühkanalbohrungen

Tap collets with seals and cooling channels
Pincettes de serrage pour tarauds avec canaux d'arrosage

Spannzangensätze im Holzsockel

Collet sets in wooden sockets
Jeux de pincettes dans socles en bois

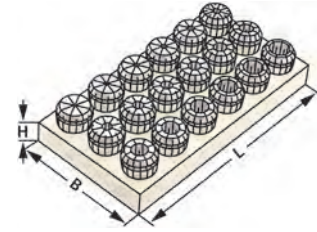

$\nabla \leq 0,015$



Bestell-Nr. Order no. Référence	Abmessung Size Dimension		L	B	H
426GC-S	426E (ER 16; 6 St.)	3,5×2,7 - 4×3 - 4,5×3,4 - 6×4,9 - 7×5,5 - 8×6,2	130	50	25
428GC-S	428E (ER 20; 8 St.)	3,5×2,7 - 4×3 - 4,5×3,4 - 6×4,9 - 7×5,5 - 8×6,2 - 9×7 - 10×8	165	110	25
430GC-S	430E (ER 25; 10 St.)	3,5×2,7 - 4×3 - 4,5×3,4 - 6×4,9 - 7×5,5 - 8×6,2 - 9×7 - 10×8 - 11×9 - 12×9	150	195	25
470GC-S	470E (ER 32; 10 St.)	4,5×3,4 - 6×4,9 - 7×5,5 - 8×6,2 - 9×7 - 10×8 - 11×9 - 12×9 - 14×11 - 16×12	190	150	30
472GC-S	472E (ER 40; 11 St.)	6×4,9 - 7×5,5 - 8×6,2 - 9×7 - 10×8 - 11×9 - 12×9 - 14×11 - 16×12 - 18×14,5 - 20×16	290	195	25

Spannzangensätze im Holzkasten

Collet sets in wooden boxes
Jeux de pincettes dans coffrets en bois



$\nabla \leq 0,015$



Bestell-Nr. Order no. Référence	Abmessung Size Dimension		L	B	H
701.426GC.1	426E (ER 16; 6 St.)	3,5×2,7 - 4×3 - 4,5×3,4 - 6×4,9 - 7×5,5 - 8×6,2	360	235	70
701.428GC.1	428E (ER 20; 8 St.)	3,5×2,7 - 4×3 - 4,5×3,4 - 6×4,9 - 7×5,5 - 8×6,2 - 9×7 - 10×8	360	235	70
701.430GC.1	430E (ER 25; 10 St.)	3,5×2,7 - 4×3 - 4,5×3,4 - 6×4,9 - 7×5,5 - 8×6,2 - 9×7 - 10×8 - 11×9 - 12×9	360	235	70
701.470GC.1	470E (ER 32; 10 St.)	4,5×3,4 - 6×4,9 - 7×5,5 - 8×6,2 - 9×7 - 10×8 - 11×9 - 12×9 - 14×11 - 16×12	360	235	70
701.472GC.1	472E (ER 40; 11 St.)	6×4,9 - 7×5,5 - 8×6,2 - 9×7 - 10×8 - 11×9 - 12×9 - 14×11 - 16×12 - 18×14,5 - 20×16	360	235	70

ER 16



9.23

ER 20



9.33

ER 25



9.43

ER 32



9.53

ER 40



9.62

Tap collets with seals
Pincas de serrage pour tarauds

Spannzangensätze im Holzsockel

Collet sets in wooden sockets

Jeux de pincas dans socles en bois

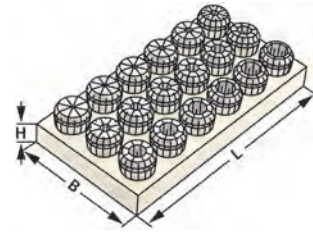

$\nabla \leq 0,015$

14.04

Bestell-Nr. Order no. Référence	Abmessung Size Dimension		L	B	H
426GA-S	426E (ER 16 6 St.)	3,5×2,7 - 4×3 - 4,5×3,4 - 6×4,9 - 7×5,5 - 8×6,2	130	50	25
428GA-S	428E (ER 20 8 St.)	3,5×2,7 - 4×3 - 4,5×3,4 - 6×4,9 - 7×5,5 - 8×6,2 - 9×7 - 10×8	165	110	25
430GA-S	430E (ER 25 10 St.)	3,5×2,7 - 4×3 - 4,5×3,4 - 6×4,9 - 7×5,5 - 8×6,2 - 9×7 - 10×8 - 11×9 - 12×9	150	195	25
470GA-S	470E (ER 32 10 St.)	4,5×3,4 - 6×4,9 - 7×5,5 - 8×6,2 - 9×7 - 10×8 - 11×9 - 12×9 - 14×11 - 16×12	190	150	30
472GA-S	472E (ER 40 11 St.)	6×4,9 - 7×5,5 - 8×6,2 - 9×7 - 10×8 - 11×9 - 12×9 - 14×11 - 16×12 - 18×14,5 - 20×16	290	195	25

Spannzangensätze im Holzkasten

Collet sets in wooden boxes

Jeux de pincas dans coffrets en bois



$\nabla \leq 0,015$

14.04

Bestell-Nr. Order no. Référence	Abmessung Size Dimension		L	B	H
701.426GA.1	426E (ER 16; 6 St.)	3,5×2,7 - 4×3 - 4,5×3,4 - 6×4,9 - 7×5,5 - 8×6,2	360	235	70
701.428GA.1	428E (ER 20; 8 St.)	3,5×2,7 - 4×3 - 4,5×3,4 - 6×4,9 - 7×5,5 - 8×6,2 - 9×7 - 10×8	360	235	70
701.430GA.1	430E (ER 25; 10 St.)	3,5×2,7 - 4×3 - 4,5×3,4 - 6×4,9 - 7×5,5 - 8×6,2 - 9×7 - 10×8 - 11×9 - 12×9	360	235	70
701.470GA.1	470E (ER 32; 10 St.)	4,5×3,4 - 6×4,9 - 7×5,5 - 8×6,2 - 9×7 - 10×8 - 11×9 - 12×9 - 14×11 - 16×12	360	235	70
701.472GA.1	472E (ER 40; 11 St.)	6×4,9 - 7×5,5 - 8×6,2 - 9×7 - 10×8 - 11×9 - 12×9 - 14×11 - 16×12 - 18×14,5 - 20×16	360	235	70

ER 16



9.24

ER 20



9.34

ER 25



9.44

ER 32



9.54

ER 40



9.63



Holzsockel, leer

Wooden sockets, empty
Socles en bois, vides



Verwendung:
Zur Aufbewahrung von Spannzangen.
Application:
For the storage of collets.
Application:
Pour la conservation de pinces.

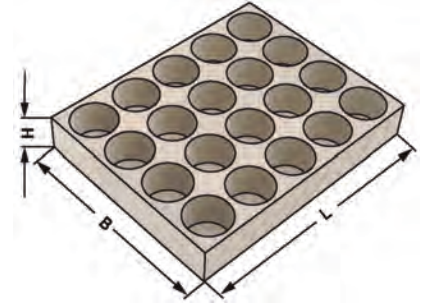

Bestell-Nr. Order no. Référence	Abmessung Size Dimension		Bohrungen Holes Trous	L	B	H
701.07.1	Gr. 7	ER 11	13	125	45	20
701.10.1	Gr. 10	ER 16	10	130	50	25
701.13.1	Gr. 13	ER 20	12	165	110	25
701.16.1	Gr. 16	ER 25 / OZ 16	20	190	155	30
701.20 / 25.1	Gr. 20 / 25	ER 32 / OZ 25	20	190	155	30
701.26 / 32.1	Gr. 26 / 32	ER 40 / OZ 32	30	290	240	30

Holzsockel, leer - System KPS

Wooden sockets, empty - system KPS
Socles en bois, vides - système KPS

9



Verwendung:
Zur Aufbewahrung von Spannzangen.
Application:
For the storage of collets.
Application:
Pour la conservation de pinces.

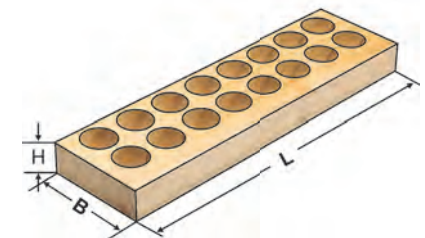

Bestell-Nr. Order no. Référence	Abmessung Size Dimension		Bohrungen Holes Trous	L	B	H
701.490	Gr. 10	KPS 10	10	280	35	22
701.496	Gr. 16	KPS 16	16	280	75	25

Wooden boxes, empty
Coffrets en bois, vides



Verwendung:
Zur Aufbewahrung von Spannzangenfuter, Spannschlüssel und Spannzangen.

Application:
For the storage of collet chuck, wrench and collets.

Application:
Pour la conservation de mandrin à pinces, clé de serrage et pinces.

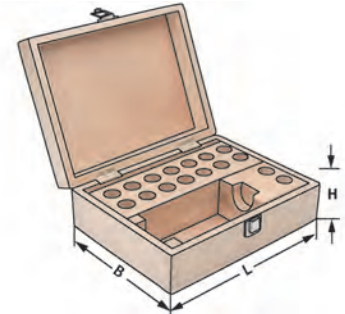

Bestell-Nr. Order no. Référence	Abmessung Size Dimension		Bohrungen Holes Trous	L	B	H
701.07	Gr. 7	ER 11	16	360	235	70
701.10	Gr. 10	ER 16	16	360	235	70
701.13	Gr. 13	ER 20	16	360	235	70
701.16	Gr. 16	ER 25 / OZ 16	16	360	235	70
701.20.25	Gr. 20 / 25	ER 32 / OZ 25	16	360	235	70
701.26.32	Gr. 26 / 32	ER 40 / OZ 32	16	360	235	70
701.R20	Gr. 20 mm	20 mm	16	360	235	70
701.R25	Gr. 25 mm	25 mm	12	360	235	70
701.R32	Gr. 32 mm	32 mm	12	360	235	70



Präzisionsspannzangen System KPS

Precision collets KPS-system

Pinces de serrage de précision système KPS



Verwendung:

Zur Aufnahme von Werkzeugen mit Zylinderschaft in Spannfutter System KPS. Für Anwendungen im HSC-Bereich und für hochpräzise Bearbeitungsergebnisse.

Application:

For mounting straight-shank tools in collet chucks KPS-system. To use for high speed cutting and high precision milling.

Application:

Pour le serrage d'outils avec queue cylindrique dans mandrins à pinces système KPS. Pour l'usage dans le coupage à grande vitesse et dans l'usinage à grande précision.

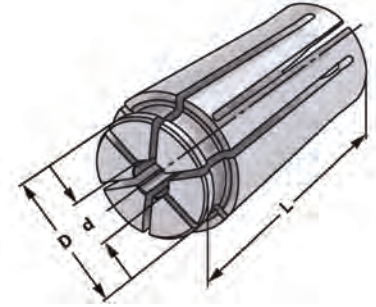

KPS

$\nearrow \leq 0,005$

Bestell-Nr. Order no. Référence	Größe Size Taille	d	D	L
490EK-010	KPS 10	1	15,5	30,5
490EK-015	KPS 10	1,5	15,5	30,5
490EK-020	KPS 10	2	15,5	30,5
490EK-025	KPS 10	2,5	15,5	30,5
490EK-030	KPS 10	3	15,5	30,5
490EK-035	KPS 10	3,5	15,5	30,5
490EK-040	KPS 10	4	15,5	30,5
490EK-045	KPS 10	4,5	15,5	30,5
490EK-050	KPS 10	5	15,5	30,5
490EK-055	KPS 10	5,5	15,5	30,5
490EK-060	KPS 10	6	15,5	30,5
490EK-065	KPS 10	6,5	15,5	30,5
490EK-070	KPS 10	7	15,5	30,5
490EK-075	KPS 10	7,5	15,5	30,5
490EK-080	KPS 10	8	15,5	30,5
490EK-085	KPS 10	8,5	15,5	30,5
490EK-090	KPS 10	9	15,5	30,5
490EK-095	KPS 10	9,5	15,5	30,5
490EK-100	KPS 10	10	15,5	30,5

9



KPS Spannzangensätze im Holzsockel

KPS collet sets in wooden sockets

KPS jeux de pinces dans socles en bois

Bestell-Nr. Abmessung

Order no. / Référence Size / Dimension

490EK-S 490 EK (KPS 10 | 9 St.) 2-3-4-5-6-7-8-9-10

Precision collets KPS-system

Pincettes de serrage de précision système KPS



Verwendung:

Zur Aufnahme von Werkzeugen mit Zylinderschaft in Spannfutter System KPS. Für Anwendungen im HSC-Bereich und für hochpräzise Bearbeitungsergebnisse.

Application:

For mounting straight-shank tools in collet chucks KPS-system. To use for high speed cutting and high precision milling.

Application:

Pour le serrage d'outils avec queue cylindrique dans mandrins à pinces système KPS. Pour l'usage dans le coupage à grande vitesse et dans l'usinage à grande précision.

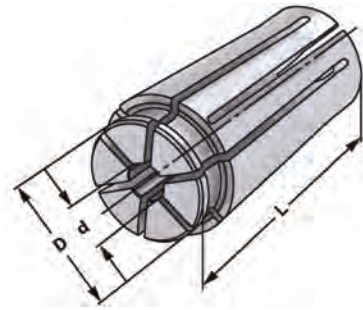

Bestell-Nr. Order no. Référence	Größe Size Taille	d	D	L
496EK-040	KPS 16	4	24,6	45
496EK-045	KPS 16	4,5	24,6	45
496EK-050	KPS 16	5	24,6	45
496EK-055	KPS 16	5,5	24,6	45
496EK-060	KPS 16	6	24,6	45
496EK-065	KPS 16	6,5	24,6	45
496EK-070	KPS 16	7	24,6	45
496EK-075	KPS 16	7,5	24,6	45
496EK-080	KPS 16	8	24,6	45
496EK-085	KPS 16	8,5	24,6	45
496EK-090	KPS 16	9	24,6	45
496EK-095	KPS 16	9,5	24,6	45
496EK-100	KPS 16	10	24,6	45
496EK-105	KPS 16	10,5	24,6	45
496EK-110	KPS 16	11	24,6	45
496EK-115	KPS 16	11,5	24,6	45
496EK-120	KPS 16	12	24,6	45
496EK-125	KPS 16	12,5	24,6	45
496EK-130	KPS 16	13	24,6	45
496EK-135	KPS 16	13,5	24,6	45
496EK-140	KPS 16	14	24,6	45
496EK-145	KPS 16	14,5	24,6	45
496EK-150	KPS 16	15	24,6	45
496EK-155	KPS 16	15,5	24,6	45
496EK-160	KPS 16	16	24,6	45



KPS Spannzangensätze im Holzsockel

KPS collet sets in wooden sockets

KPS jeux de pinces dans socles en bois

Bestell-Nr. Order no. / Référence	Abmessung Size / Dimension
496EK-S	496 EK (KPS 16 13 St.) 4-5-6-7-8-9-10-11-12-13-14-15-16



Präzisionsspannzangen abgedichtet System KPS bis 100 bar

Precision collets sealed KPS-system until 100 bar

Pincettes de serrage de précision étanche système KPS pour arrosage de haute pression 100 bar



Verwendung:

Zur Aufnahme von Werkzeugen mit Zylinderschaft in Spannfutter System KPS. Für Anwendungen im HSC-Bereich und für hochpräzise Bearbeitungsergebnisse.

Application:

For mounting straight-shank tools in collet chucks KPS-system. To use for high speed cutting and high precision milling.

Application:

Pour le serrage d'outils avec queue cylindrique dans mandrins à pincettes système KPS. Pour l'usage dans le coupage à grande vitesse et dans l'usinage à grande précision.

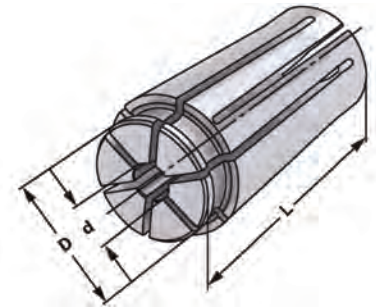

KPS $\rightarrow \leq 0,005$

14.04

Bestell-Nr. Order no. Référence	Größe Size Taille	d	D	L
490RD-030	KPS 10	3	15,5	30,5
490RD-040	KPS 10	4	15,5	30,5
490RD-050	KPS 10	5	15,5	30,5
490RD-060	KPS 10	6	15,5	30,5
490RD-070	KPS 10	7	15,5	30,5
490RD-080	KPS 10	8	15,5	30,5
490RD-090	KPS 10	9	15,5	30,5
490RD-100	KPS 10	10	15,5	30,5

9



KPS Spannzangensätze abgedichtet im Holzsockel

KPS collet sets sealed in wooden sockets

KPS jeux de pincettes étanche dans socles en bois

Bestell-Nr. Order no. / Référence	Abmessung Size / Dimension
490RD-S	490 EK (KPS 10 8 St.) 3-4-5-6-7-8-9-10



Precision collets sealed KPS-system until 100 bar

Pincés de serrage de précision étanche système KPS pour arrosage de haute pression 100 bar



Verwendung:

Zur Aufnahme von Werkzeugen mit Zylinderschaft in Spannfutter System KPS. Für Anwendungen im HSC-Bereich und für hochpräzise Bearbeitungsergebnisse.

Application:

For mounting straight-shank tools in collet chucks KPS-system. To use for high speed cutting and high precision milling.

Application:

Pour le serrage d'outils avec queue cylindrique dans mandrins à pincés système KPS. Pour l'usage dans le coupage à grande vitesse et dans l'usinage à grande précision.

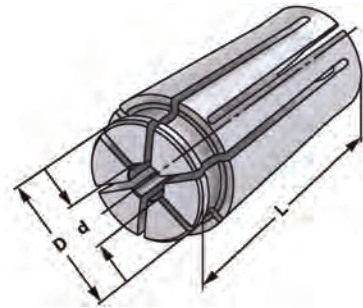

KPS $\nabla \leq 0,005$

14.04

Bestell-Nr. Order no. Référence	Größe Size Taille	d	D	L
496RD-040	KPS 16	4	24,6	45
496RD-050	KPS 16	5	24,6	45
496RD-060	KPS 16	6	24,6	45
496RD-070	KPS 16	7	24,6	45
496RD-080	KPS 16	8	24,6	45
496RD-090	KPS 16	9	24,6	45
496RD-100	KPS 16	10	24,6	45
496RD-110	KPS 16	11	24,6	45
496RD-120	KPS 16	12	24,6	45
496RD-130	KPS 16	13	24,6	45
496RD-140	KPS 16	14	24,6	45
496RD-150	KPS 16	15	24,6	45
496RD-160	KPS 16	16	24,6	45



KPS Spannzangensätze abgedichtet im Holzsockel

KPS collet sets sealed in wooden sockets

KPS jeux de pincés étanche dans socles en bois

Bestell-Nr. Order no. / Référence	Abmessung Size / Dimension
496RD-S	496 EK (KPS 16 13 St.) 4-5-6-7-8-9-10-11-12-13-14-15-16





Reduzierungen für Hochleistungs-Kraftspannfutter System HKS für innere Kühlmittelzufuhr, Bund geschlossen, kühlmitteldicht bis max. 80 bar

Reduction sleeves for high performance milling chucks system HKS for internal coolant supply, closed collar, coolant proof up to max. 80 bar

Douilles de réduction pour mandrins de serrage à haute performance HKS avec arrosage centrale, collerette pleine, étanche au liquide d'arrosage jusqu'à 80 bar max.



Verwendung:
Zur Aufnahme von Werkzeugen mit Zylinderschaft und innerer Kühlmittelzufuhr.

Application:
For mounting straight-shank tools with internal coolant.

Application:
Pour le serrage d'outils avec queue cylindrique et arrosage centrale.

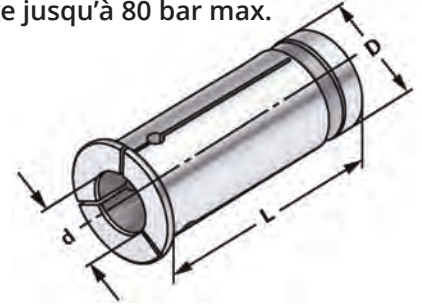

$\nabla \leq 0,005$



Bestell-Nr. Order no. Référence	D	d	L
HKS.RD20.030	20	3	52,9
HKS.RD20.040	20	4	52,9
HKS.RD20.050	20	5	52,9
HKS.RD20.060	20	6	52,9
HKS.RD20.080	20	8	52,9
HKS.RD20.100	20	10	52,9
HKS.RD20.120	20	12	52,9
HKS.RD20.140	20	14	52,9
HKS.RD20.160	20	16	52,9
HKS.RD25.030	25	3	52,5
HKS.RD25.040	25	4	52,5
HKS.RD25.050	25	5	52,5
HKS.RD25.060	25	6	52,5
HKS.RD25.080	25	8	52,5
HKS.RD25.100	25	10	52,5
HKS.RD25.120	25	12	52,5
HKS.RD25.140	25	14	52,5
HKS.RD25.160	25	16	52,5
HKS.RD25.180	25	18	52,5
HKS.RD25.200	25	20	52,5
HKS.RD32.030	32	3	66,0
HKS.RD32.040	32	4	66,0
HKS.RD32.050	32	5	66,0
HKS.RD32.060	32	6	66,0
HKS.RD32.080	32	8	66,0
HKS.RD32.100	32	10	66,0
HKS.RD32.120	32	12	66,0
HKS.RD32.140	32	14	66,0
HKS.RD32.160	32	16	66,0
HKS.RD32.180	32	18	66,0
HKS.RD32.200	32	20	66,0
HKS.RD32.250	32	25	66,0

Hinweis: Der Spanndurchmesser ist für eine Werkzeugtoleranz h_6 ausgelegt.
Note: *The chucking diameter is configured for a tool tolerance of h_6 .*
Observation: Le diamètre de serrage est conçu pour une tolérance d'outil h_6 .

für Peripheriekühlung, Bund geschlitzt, nicht kühlmitteldicht

Reduction sleeves for high performance milling chucks system HKS with peripheral cooling, collar slotted, not coolant proof

Douilles de réduction pour mandrins de serrage à haute performance HKS pour arrosage périphérique, collerette fendue, non étanche au liquide d'arrosage



Verwendung:
Zur Aufnahme von Werkzeugen mit Zylinderschaft.

Application:
For mounting straight-shank tools.

Application:
Pour le serrage d'outils avec queue cylindrique.

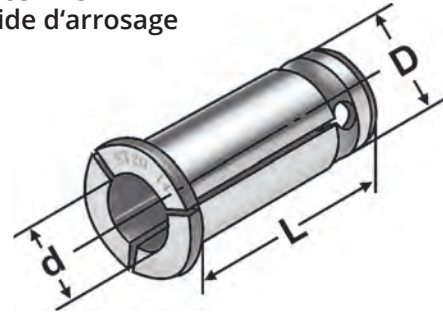

$\nabla \leq 0,005$

14.04

Bestell-Nr. Order no. Référence	D	d	L
HKS20.030	20	3	53,0
HKS20.040	20	4	53,0
HKS20.050	20	5	53,0
HKS20.060	20	6	53,0
HKS20.080	20	8	53,0
HKS20.100	20	10	53,0
HKS20.120	20	12	53,0
HKS20.140	20	14	53,0
HKS20.160	20	16	53,0
HKS25.060	25	6	60,0
HKS25.080	25	8	60,0
HKS25.100	25	10	60,0
HKS25.120	25	12	60,0
HKS25.140	25	14	60,0
HKS25.160	25	16	60,0
HKS25.180	25	18	60,0
HKS25.200	25	20	60,0
HKS32.060	32	6	73,0
HKS32.080	32	8	73,0
HKS32.100	32	10	73,0
HKS32.120	32	12	73,0
HKS32.140	32	14	73,0
HKS32.160	32	16	73,0
HKS32.180	32	18	73,0
HKS32.200	32	20	73,0
HKS32.250	32	25	73,0

Hinweis: Der Spanndurchmesser ist für eine Werkzeugtoleranz h_6 ausgelegt.
Note: *The chucking diameter is configured for a tool tolerance of h_6 .*
Observation: Le diamètre de serrage est conçu pour une tolérance d'outil h_6 .



Reduzierungen für Hydrodehnspannfutter

für innere Kühlmittelzufuhr, Bund geschlossen, kühlmitteldicht bis max. 80 bar

Reduction sleeves for hydraulic expansion chucks for internal coolant supply, closed collar, coolant proof up to max. 80 bar

Douilles de réduction pour mandrins expansibles hydrauliques avec arrosage centrale, collerette pleine, étanche au liquide d'arrosage jusqu'à 80 bar max.



Verwendung:

Zur Aufnahme von Werkzeugen mit Zylinderschaft und innerer Kühlmittelzufuhr.

Application:

For mounting straight-shank tools with internal coolant.

Application:

Pour le serrage d'outils avec queue cylindrique et arrosage centrale.

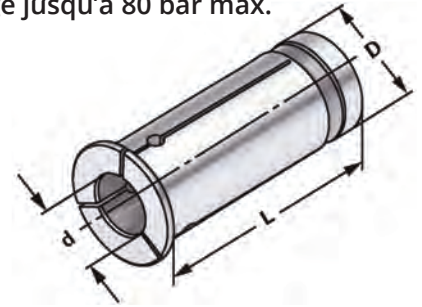

$\nabla \leq 0,005$



Bestell-Nr. Order no. Référence	D	d	L
RD20.030	20	3	52,9
RD20.040	20	4	52,9
RD20.050	20	5	52,9
RD20.060	20	6	52,9
RD20.080	20	8	52,9
RD20.100	20	10	52,9
RD20.120	20	12	52,9
RD20.140	20	14	52,9
RD20.160	20	16	52,9
RD25.030	25	3	52,5
RD25.040	25	4	52,5
RD25.050	25	5	52,5
RD25.060	25	6	52,5
RD25.080	25	8	52,5
RD25.100	25	10	52,5
RD25.120	25	12	52,5
RD25.140	25	14	52,5
RD25.160	25	16	52,5
RD25.180	25	18	52,5
RD25.200	25	20	52,5
RD32.030	32	3	66,0
RD32.040	32	4	66,0
RD32.050	32	5	66,0
RD32.060	32	6	66,0
RD32.080	32	8	66,0
RD32.100	32	10	66,0
RD32.120	32	12	66,0
RD32.140	32	14	66,0
RD32.160	32	16	66,0
RD32.180	32	18	66,0
RD32.200	32	20	66,0
RD32.250	32	25	66,0

Hinweis: Der Spanndurchmesser ist für eine Werkzeugtoleranz h_6 ausgelegt.
Note: *The chucking diameter is configured for a tool tolerance of h_6 .*
Observation: Le diamètre de serrage est conçu pour une tolérance d'outil h_6 .

für Peripheriekühlung, Bund geschlitzt, nicht kühlmitteldicht

Reduction sleeves for hydraulic expansion chucks with peripheral cooling, collar slotted, not coolant proof
Douilles de réduction pour mandrins expansibles hydrauliques
pour arrosage périphérique, collerette fendue, non étanche au liquide d'arrosage



Verwendung:
 Zur Aufnahme von Werkzeugen mit Zylinderschaft.
Application:
 For mounting straight-shank tools.
Application:
 Pour le serrage d'outils avec queue cylindrique.

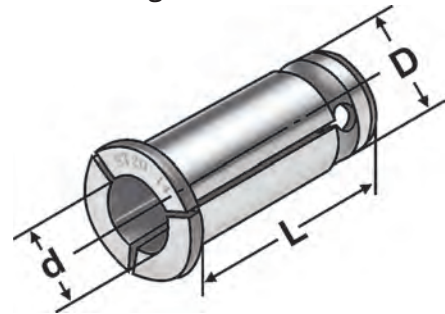

$\nabla \leq 0,005$

14.04

Bestell-Nr. Order no. Référence	D	d	L
R20.030	20	3	53,00
R20.040	20	4	53,00
R20.050	20	5	53,00
R20.060	20	6	53,00
R20.080	20	8	53,00
R20.100	20	10	53,00
R20.120	20	12	53,00
R20.140	20	14	53,00
R20.160	20	16	53,00
R25.030	25	3	60,00
R25.040	25	4	60,00
R25.050	25	5	60,00
R25.060	25	6	60,00
R25.080	25	8	60,00
R25.100	25	10	60,00
R25.120	25	12	60,00
R25.140	25	14	60,00
R25.160	25	16	60,00
R25.180	25	18	60,00
R25.200	25	20	60,00
R32.060	32	6	64,60
R32.080	32	8	64,60
R32.100	32	10	64,60
R32.120	32	12	64,60
R32.140	32	14	64,60
R32.160	32	16	64,60
R32.180	32	18	64,60
R32.200	32	20	64,60
R32.250	32	25	64,60

Hinweis: Der Spanndurchmesser ist für eine Werkzeugtoleranz h_6 ausgelegt.
Note: *The chucking diameter is configured for a tool tolerance of h_6 .*
Observation: Le diamètre de serrage est conçu pour une tolérance d'outil h_6 .

ZUBEHÖR
ACCESSORIES
ACCESSOIRES

ZUBEHÖR

ACCESSORIES

ACCESSOIRES





10.04	10.06	10.10	10.18
 KPS	 HKS		
10.21	10.24	10.27	10.30
			
10.36	10.38	10.39	10.40
			
10.46	10.47	10.48	10.50
			
10.51	10.52	10.60	10.62
			

10.63	10.64	10.65	10.66
10.67	10.69	10.70	10.72
10.74	10.76	10.77	10.79
10.81	10.82	10.83	10.84
10.86			



Spannmuttern System KPS

Clamping nuts KPS-system
Ecrous de serrage système KPS



Verwendung:
Für Spannanzgen System KPS.
Application:
For collets KPS-system.
Application:
Pour pinces de serrage système KPS.

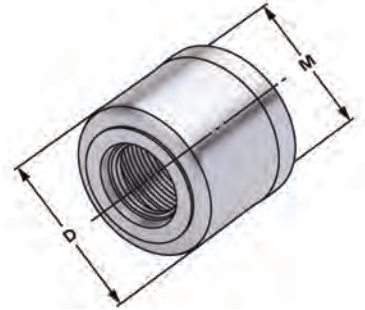

Bestell-Nr. Order no. Référence	Spannbereich Capacity Capacité	D	M
490EK-181	KPS 10	28	M21,5 × 1,0
496EK-181	KPS 16	40	M32,0 × 1,5

Montagehilfe System KPS

Collet extractor KPS-system
Moyen d'assemblage système KPS



Verwendung:
Zur Montage und Demontage der Spannanzgen System KPS.
Application:
For the assembly and disassembly of collets KPS-system.
Application:
Pour l'assemblage et désassemblage de pinces de de serrage système KPS.

10

Bestell-Nr. Order no. Référence	Abmessung Size Dimension
490EK-183	KPS 10
496EK-183	KPS 16



Spannschlüssel für Spannmutter System KPS



Wrenches for clamping nuts KPS-system

Clés de serrage pour écrous de serrage système KPS



Verwendung:
Für Spannmutter System KPS.
Application:
For clamping nuts KPS-system.
Application:
Pour écrous de serrage système KPS.

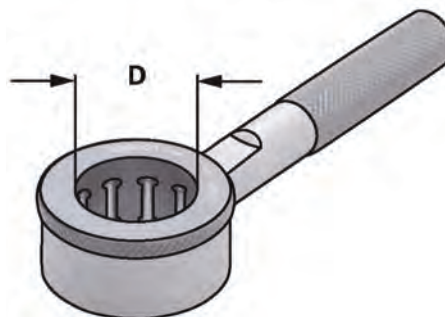

Bestell-Nr. Order no. Référence	Abmessung Size Dimension	D
490EK-182	KPS 10	28
496EK-182	KPS 16	40

Einstellschraube für innere Kühlmittelzufuhr System KPS

Setting screw for for internal cooling KPS-system

Vis de réglage pour l`arrosage centrale pour système KPS



Verwendung:
Zur Abdichtung von Werkzeugen mit
Innenkühlung.
Application:
For sealing tools with internal cooling.
Application:
Pour assurer l'étanchéité en cas
d'utilisation d'outils avec lubrification
interne.

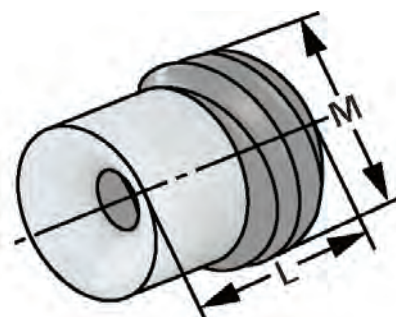

10

Bestell-Nr. Order no. Référence	Abmessung Size Dimension	L	M
490EK-184	KPS 10	12,5	M12 x 1,75
496EK-184	KPS 16	16,3	M18 x 1,50





Hakenschlüssel für System HKS

Wrenches for system HKS
Clés à ergot pour système HKS



Verwendung:
Zum Spannen der HKS Spannfutter.
Application:
For clamping the HKS collet chucks.
Application:
Pour le serrage des mandrins système HKS.

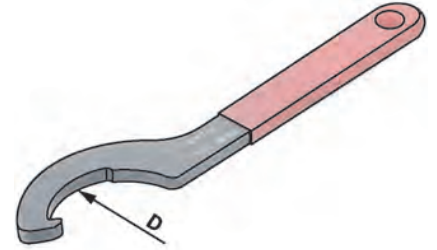

Bestell-Nr. Order no. Référence	Abmessung Size Dimension	D
64.182.20	HKS 20	50
64.182.32	HKS 25 + HKS 32	60

Auszieher für Reduzierungen System HKS

Extractor for reduction sleeves system HKS
Extracteur pour douilles de réduction système HKS



Verwendung:
Zum Herausziehen der Reduzierungen.
Application:
For extracting the reduction sleeves.
Application:
Pour extraire les douilles de réduction.

10

Bestell-Nr. Order no. Référence	Abmessung Size Dimension
64.187.2032	HKS 20 / HKS 25 / HKS 32

Setting screw for system HKS
Vis de réglage pour système HKS



Verwendung:
Zum Einstellen des Werkzeuges bei HKS Spannfutter.
Application:
For setting the tool in the HKS collet chucks.
Application:
Pour régler l'outil dans le mandrin HKS.

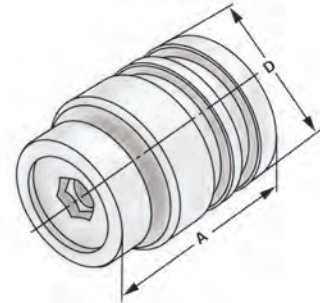

Bestell-Nr. Order no. Référence	Abmessung Size Dimension	A	D
HKS20.184*	HKS 20	30	19
HKS25.184*	HKS 25	30	24
HKS32.184*	HKS 32	38	31

* Nicht mit Reduzierungen einsetzbar
* Not applicable with reductions
* Pas utilisable avec réductions





HKS Kraftspannfutter im Holzkasten mit Reduzierungen nicht kühlmitteldicht

HKS Milling chuck in wooden box with reduction bushes, not coolant proof
HKS mandrin de serrage dans coffret en bois avec douilles de réduction, pas étanche

Bestell-Nr. Order no. / Référence	Abmessung Size / Dimension
403.64.20.SR	(HKS20 ; 5 St.) 6-8-10-12-16
403.64.25.SR	(HKS25 ; 6 St.) 6-8-10-12-16-20
403.64.32.SR	(HKS32 ; 7 St.) 6-8-10-12-16-20-25
503.64.20.SR	(HKS20 ; 5 St.) 6-8-10-12-16
503.64.25.SR	(HKS25 ; 6 St.) 6-8-10-12-16-20
503.64.32.SR	(HKS32 ; 7 St.) 6-8-10-12-16-20-25
406.64.20.SR	(HKS20 ; 5 St.) 6-8-10-12-16
406.64.25.SR	(HKS25 ; 6 St.) 6-8-10-12-16-20
406.64.32.SR	(HKS32 ; 7 St.) 6-8-10-12-16-20-25
506.64.20.SR	(HKS20 ; 5 St.) 6-8-10-12-16
506.64.25.SR	(HKS25 ; 6 St.) 6-8-10-12-16-20
506.64.32.SR	(HKS32 ; 7 St.) 6-8-10-12-16-20-25
A63.64.20.SR	(HKS20 ; 5 St.) 6-8-10-12-16
A63.64.25.SR	(HKS25 ; 6 St.) 6-8-10-12-16-20
A63.64.32.SR	(HKS32 ; 7 St.) 6-8-10-12-16-20-25
A100.64.20.SR	(HKS20 ; 5 St.) 6-8-10-12-16
A100.64.25.SR	(HKS25 ; 6 St.) 6-8-10-12-16-20
A100.64.32.SR	(HKS32 ; 7 St.) 6-8-10-12-16-20-25



System HKS
Système HKS



HKS Kraftspannfutter im Holzkasten mit Reduzierungen, kühlmitteldicht

HKS Milling chuck in wooden box with reduction bushes, coolant proof

HKS mandrin de serrage dans coffret en bois avec douilles de réduction, étanche

Bestell-Nr. Order no. / Référence	Abmessung Size / Dimension
403.64.20.SRD	(HKS20 RD; 5 St.) 6-8-10-12-16
403.64.25.SRD	(HKS25 RD; 6 St.) 6-8-10-12-16-20
403.64.32.SRD	(HKS32 RD; 7 St.) 6-8-10-12-16-20-25
503.64.20.SRD	(HKS20 RD; 5 St.) 6-8-10-12-16
503.64.25.SRD	(HKS25 RD; 6 St.) 6-8-10-12-16-20
503.64.32.SRD	(HKS32 RD; 7 St.) 6-8-10-12-16-20-25
406.64.20.SRD	(HKS20 RD; 5 St.) 6-8-10-12-16
406.64.25.SRD	(HKS25 RD; 6 St.) 6-8-10-12-16-20
406.64.32.SRD	(HKS32 RD; 7 St.) 6-8-10-12-16-20-25
506.64.20.SRD	(HKS20 RD; 5 St.) 6-8-10-12-16
506.64.25.SRD	(HKS25 RD; 6 St.) 6-8-10-12-16-20
506.64.32.SRD	(HKS32 RD; 7 St.) 6-8-10-12-16-20-25
A63.64.20.SRD	(HKS20 RD; 5 St.) 6-8-10-12-16
A63.64.25.SRD	(HKS25 RD; 6 St.) 6-8-10-12-16-20
A63.64.32.SRD	(HKS32 RD; 7 St.) 6-8-10-12-16-20-25
A100.64.20.SRD	(HKS20 RD; 5 St.) 6-8-10-12-16
A100.64.25.SRD	(HKS25 RD; 6 St.) 6-8-10-12-16-20
A100.64.32.SRD	(HKS32 RD; 7 St.) 6-8-10-12-16-20-25





Spannmuttern ISO 10897 (DIN 6388 D) System OZ, kugelgelagerte Ausführung

Clamping nuts ISO 10897 (DIN 6388 D) OZ-system, ball-bearing version

Ecrous de serrage ISO 10897 (DIN 6388 D) système OZ, version roulement à billes



Verwendung:

Alle Spannzangen mit Außenform ISO 10897 (DIN 6388 D) können gespannt werden.

Application:

All collets with outside form ISO 10897 (DIN 6388 D) can be clamped.

Application:

Toutes les pinces avec une forme extérieure suivant ISO 10897 (DIN 6388 D) peuvent être serrées.

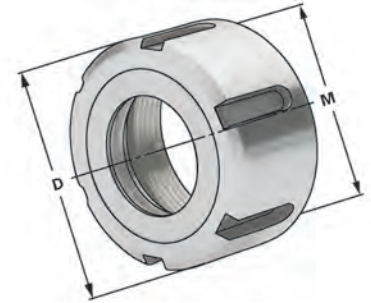

Bestell-Nr. Order no. Référence	Spannbereich Capacity Capacité	D	M
112.01.16	2 – 16 (OZ 16)	43	M33 × 1,5
112.01.25	2 – 25 (OZ 25)	60	M48 × 2
112.01.32	3 – 32 (OZ 32)	72	M60 × 2,5

Spannmuttern ISO 15488 (DIN 6499) System ER - Mini Standardausführung mit Exzenterring, gewuchtet

Clamping nuts ISO 15488 (DIN 6499) ER-system - Mini, standard type with eccentric ring, balanced
Ecrous de serrage ISO 15488 (DIN 6499) système ER - Mini, version standard avec bague excentrique, équilibrés

10



Verwendung:

Alle Spannzangen mit Außenform ISO 15488 (DIN 6499) können gespannt werden.

Application:

All collets with outside form ISO 15488 (DIN 6499) can be clamped.

Application:

Toutes les pinces avec une forme extérieure suivant ISO 15488 (DIN 6499) peuvent être serrées.

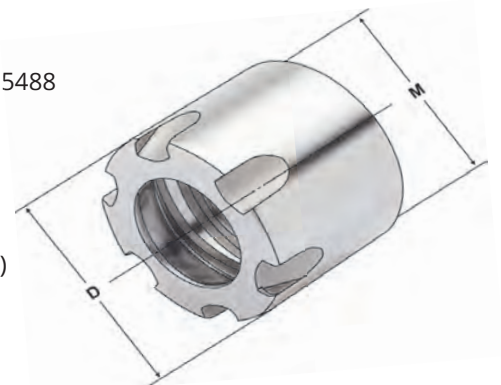

Bestell-Nr. Order no. Référence	Spannbereich Capacity Capacité	D	M
110.02.07.3	1 – 7 (ER 11)	16	M13 × 0,75
110.02.10.3	1 – 10 (ER 16)	22	M19 × 1
110.02.13.3	2 – 13 (ER 20)	28	M24 × 1
110.02.16.3	2 – 16 (ER 25)	35	M30 × 1

Spannmuttern ISO 15488 (DIN 6499) System ER,

Standardausführung mit Exzenterring, gewuchtet



Clamping nuts ISO 15488 (DIN 6499) ER-system, standard type with eccentric ring, balanced

Ecrous de serrage ISO 15488 (DIN 6499) système ER, version standard avec bague excentrique, équilibrés



Verwendung:

Alle Spannzangen mit Außenform ISO 15488 (DIN 6499) können gespannt werden.

Application:

All collets with outside form ISO 15488 (DIN 6499) can be clamped.

Application:

Toutes les pinces avec une forme extérieure suivant ISO 15488 (DIN 6499) peuvent être serrées.

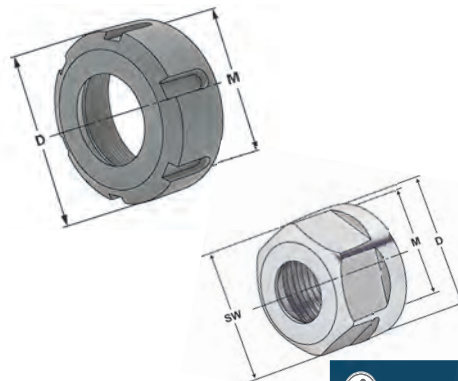

Bestell-Nr. Order no. Référence	Spannbereich Capacity Capacité	D	sw	M
110.02.07.6 *	1 – 7 (ER 11)	19	17	M14 × 0,75
110.02.10	1 – 10 (ER 16)	32		M22 × 1,5
110.02.10.6 *	1 – 10 (ER 16)	28	25	M22 × 1,5
110.02.13	2 – 13 (ER 20)	35		M25 × 1,5
110.02.13.6 *	2 – 13 (ER 20)	34	30	M25 × 1,5
110.02.16	2 – 16 (ER 25)	42		M32 × 1,5
110.02.20	2 – 20 (ER 32)	50		M40 × 1,5
110.02.26	3 – 26 (ER 40)	63		M50 × 1,5

* Sechskantmutter

* Hexagonal clamping nut

* Écrou hexagonal

Spannmuttern ISO 15488 (DIN 6499) System ER, gleitgelagerte Ausführung

Clamping nuts ISO 15488 (DIN 6499) ER-system, sleeve-bearing version

Ecrous de serrage à palier lisse pour pinces ISO 15488 (DIN 6499) système ER



Verwendung:

Alle Spannzangen mit Außenform ISO 15488 (DIN 6499) können gespannt werden.

Application:

All collets with outside form ISO 15488 (DIN 6499) can be clamped.

Application:

Toutes les pinces avec une forme extérieure suivant ISO 15488 (DIN 6499) peuvent être serrées.

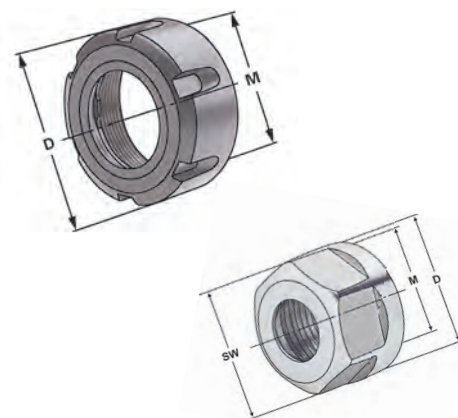

10

Bestell-Nr. Order no. Référence	Spannbereich Capacity Capacité	D	sw	M
112.02.10*	1 – 10 (ER 16)	28	25	M22 × 1,5
112.02.16	2 – 16 (ER 25)	42		M32 × 1,5
112.02.20	2 – 20 (ER 32)	50		M40 × 1,5
112.02.26	3 – 26 (ER 40)	63		M50 × 1,5

* Sechskantmutter

* Hexagonal clamping nut

* Écrou hexagonal



Spannmuttern ISO 10897 (DIN 6388 D) System OZ, für Dichtscheiben

Clamping nuts ISO 10897 (DIN 6388 D) OZ-system, for sealing discs
Ecrous de serrage ISO 10897 (DIN 6388 D) système OZ, pour joints

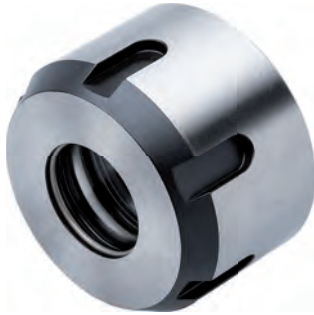

Verwendung:

Zur Abdichtung von Werkzeugen mit Innenkühlung in Spannfutter DIN 6391, System OZ.

Application:

For sealing tools with internal cooling in collet chucks DIN 6391, OZ-system.

Application:

Pour assurer l'étanchéité en cas d'utilisation d'outils avec lubrification interne dans mandrins à pinces DIN6391, système OZ.

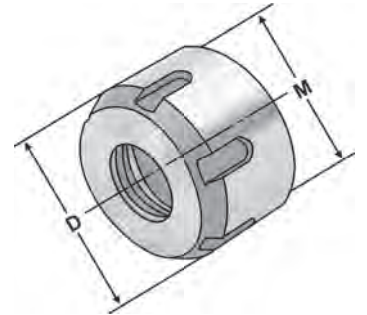

Bestell-Nr. Order no. Référence	Spannbereich Capacity Capacité	D	M
113.01.16	2 – 16 (OZ 16)	43	M33 × 1,5
113.01.25	2 – 25 (OZ 25)	60	M48 × 2
113.01.32	3 – 32 (OZ 32)	72	M60 × 2,5

Hinweis: Dichtscheiben sind getrennt zu bestellen.
Note: Sealing discs be ordered separately.
Observation: Joints doivent être commandés séparément.



Sealing discs for clamping nuts OZ-system
 Joints pour écrous de serrage système OZ



Verwendung:
 Zur Abdichtung von Werkzeugen mit
 Innenkühlung.
Application:
 For sealing tools with internal cooling.
Application:
 Pour assurer l'étanchéité en cas
 d'utilisation d'outils avec lubrification
 interne.

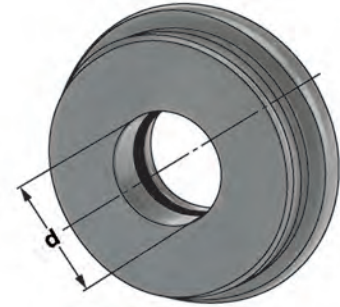

Bestell-Nr. Order no. Référence	Spannbereich Capacity Capacité	d*
01.16.xxx	2 – 16 (OZ 16)	2 – 16
01.25.xxx	2 – 25 (OZ 25)	2 – 25
01.32.xxx	3 – 32 (OZ 32)	3 – 32

d* Ø des Werkzeugs
 Spannüberbrückung 0,5 mm (+0,1/-0,4)
 d* Ø of the tool
 Clamping range 0.5 mm (+0.1/-0.4)
 d* Ø d'outil
 Plage de serrage de 0,5 mm (+0,1/-0,4)

Hinweis: Dicht bis 80 bar Druck
Note: Sealing capacity up to 80 bar
Observation: Étanche jusqu'à la pression de 80 bar



Spannmuttern ISO 15488 (DIN 6499) System ER, für Dichtscheiben

Clamping nuts ISO 15488 (DIN 6499) ER-system, for sealing discs
Ecrus de serrage ISO 15488 (DIN 6499) système ER, pour joints



Verwendung:
Zur Abdichtung von Werkzeugen mit Innenkühlung in Spannfutter, System ER.
Application:
For sealing tools with internal cooling in collet chucks, ER-system.
Application:
Pour assurer l'étanchéité en cas d'utilisation d'outils avec lubrification interne dans mandrins à pinces, système ER.

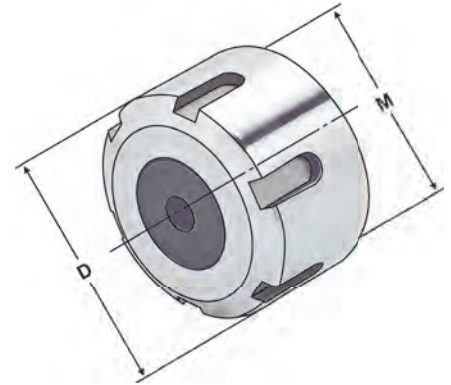

Bestell-Nr. Order no. Référence	Spannbereich Capacity Capacité	D	M
113.02.13	3 – 13 (ER 20)	35	M25 × 1,5
113.02.16	2 – 16 (ER 25)	42	M32 × 1,5
113.02.20	2 – 20 (ER 32)	50	M40 × 1,5
113.02.26	3 – 26 (ER 40)	63	M50 × 1,5

Hinweis: Dichtscheiben sind getrennt zu bestellen.
Note: Sealing discs be ordered separately.
Observation: Joints doivent être commandés séparément.

Spannmuttern ISO 15488 (DIN 6499) System ER - Sechskantmutter, für Dichtscheiben

Clamping nuts ISO 15488 (DIN 6499) ER-system - Hexagonal clamping nut, for sealing discs
Ecrus de serrage ISO 15488 (DIN 6499) système ER - Écrou hexagonal, pour joints



Verwendung:
Zur Abdichtung von Werkzeugen mit Innenkühlung in Spannfutter, System ER.
Application:
For sealing tools with internal cooling in collet chucks, ER-system.
Application:
Pour assurer l'étanchéité en cas d'utilisation d'outils avec lubrification interne dans mandrins à pinces, système ER.

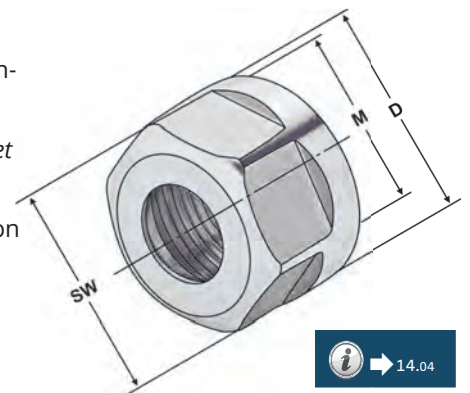

Bestell-Nr. Order no. Référence	Spannbereich Capacity Capacité	D	SW	M
113.02.10	1 – 10 (ER 16)	28	25	M22 × 1,5

Hinweis: Dichtscheiben sind getrennt zu bestellen.
Note: Sealing discs be ordered separately.
Observation: Joints doivent être commandés séparément.

Spannmuttern ISO 15488 (DIN 6499) System ER Mini, für Dichtscheiben



Clamping nuts ISO 15488 (DIN 6499) ER-system Mini, for sealing discs
Ecrous de serrage ISO 15488 (DIN 6499) système ER Mini, pour joints

Minimutter
Mini nut
Écrous mini



Verwendung:
Zur Abdichtung von Werkzeugen mit Innenkühlung in Spannfutter, System ER.

Application:
For sealing tools with internal cooling in collet chucks, ER-system.

Application:
Pour assurer l'étanchéité en cas d'utilisation d'outils avec lubrification interne dans mandrins à pinces, système ER.

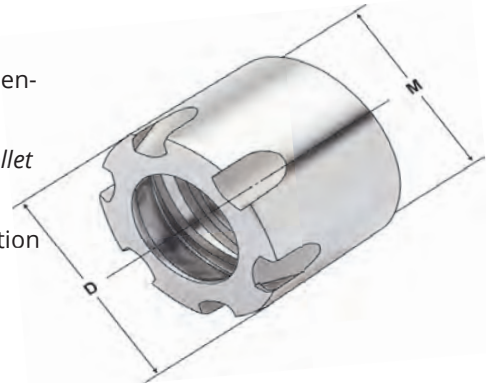

Bestell-Nr. Order no. Référence	Spannbereich Capacity Capacité	D	M
113.02.10M	1 – 10 (ER 16)	22	M19 × 1

Hinweis: Dichtscheiben sind getrennt zu bestellen.
Note: Sealing discs be ordered separately.
Observation: Joints doivent être commandés séparément.

Spannmuttern ISO 15488 (DIN 6499) System ER, mit Spritzdüsen, für Dichtscheiben

Clamping nuts ISO 15488 (DIN 6499) ER-system, with spray nozzles, for sealing discs
Ecrous de serrage ISO 15488 (DIN 6499) système ER, avec gicleurs, pour joints



Verwendung:
Zur Abdichtung von Werkzeugen mit Innenkühlung in Spannfutter, System ER mit Spritzdüsen.

Application:
For sealing tools with internal cooling in collet chucks, ER-system with spray nozzles.

Application:
Pour assurer l'étanchéité en cas d'utilisation d'outils avec lubrification interne dans mandrins à pinces, système ER avec buses d'injection.

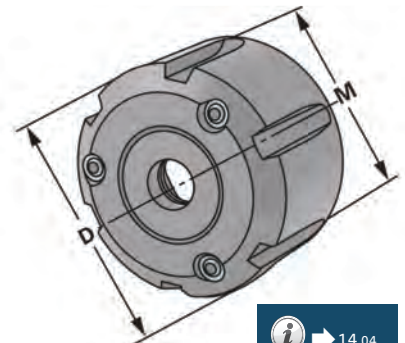

Bestell-Nr. Order no. Référence	Spannbereich Capacity Capacité	D	sw	M
114.02.10*	1 – 10 (ER 16)	28	25	M22 × 1,5
114.02.16	2 – 16 (ER 25)	42		M32 × 1,5
114.02.20	2 – 20 (ER 32)	50		M40 × 1,5
114.02.26	3 – 26 (ER 40)	63		M50 × 1,5

* Sechskantmutter
* Hexagonal clamping nut
* Écrou hexagonal

Hinweis: Dichtscheiben sind getrennt zu bestellen.
Note: Sealing discs be ordered separately.
Observation: Joints doivent être commandés séparément.

10



Dichtscheiben für Spannmuttern System ER

Sealing discs for clamping nuts ER-system
Joints pour écrous de serrage système ER



Verwendung:
Zur Abdichtung von Werkzeugen mit
Innenkühlung.

Application:
For sealing tools with internal cooling.

Application:
Pour assurer l'étanchéité en cas
d'utilisation d'outils avec lubrification
interne.

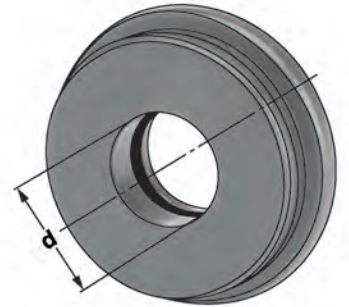

Bestell-Nr. Order no. Référence	Spannbereich Capacity Capacité	d*
02.10M.xxx**	3 – 10 (ER 16) Mini	3,0 – 10,0
02.10.xxx	1 – 10 (ER 16)	1,0 – 10,0
02.13.xxx	3 – 13 (ER 20)	3,0 – 13,0
02.16.xxx	2 – 16 (ER 25)	1,0 – 16,0
02.20.xxx	2 – 20 (ER 32)	1,0 – 20,0
02.26.xxx	3 – 26 (ER 40)	2,0 – 26,0

** Minimutter
** Mini nut
** Écrous mini

d* Ø des Werkzeugs
Spannüberbrückung 0,5 mm (+0,1/-0,4)

d* Ø of the tool
Clamping range 0.5 mm (+0.1/-0.4)

d* Ø d'outil
Plage de serrage de 0,5 mm (+0,1/-0,4)

Hinweis: Dicht bis 80 bar Druck
Note: Sealing capacity up to 80 bar
Observation: Étanche jusqu'à la pression de 80 bar



Technische Datenblätter, STEP/STL Modelle für die Simulation der NC-Programme und DXF-Zeichnungen zur Erstellung des Einrichteblattes stehen Online zur Verfügung.

Technical data sheets, STEP/STL models for the simulation of NC programs and DXF drawings to create the tooling sheet are online available.

Fiches techniques, STEP/STL modèles techniques pour la simulation de programmes CN et dessins DXF pour créer la feuille d'installation sont disponible online.

Sie können unsere Kataloge entweder direkt im Browser betrachten oder sie auf Ihren PC, Smartphone oder Tablet herunterladen (PDF-Reader notwendig).

You can view our catalogues either directly in the browser or download to your PC, smartphone or tablet (PDF reader required).

Vous pouvez consulter nos catalogues directement dans le navigateur ou télécharger sur votre PC, smartphone ou tablet (lecteur PDF requis).

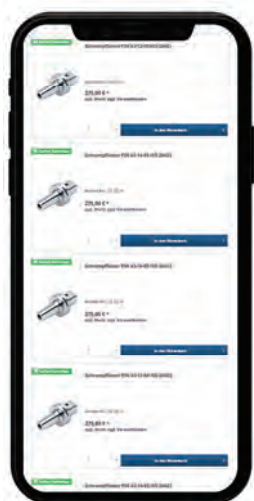

Auf unserer Internetseite können Sie auch die Lagerverfügbarkeit prüfen - auch auf Mobilgeräten.

On our website you can also check the stock availability - also on mobile devices.

Vous pouvez également vérifier la disponibilité de nos produits sur le site Internet - ainsi que sur vos appareils



Drehmomentschlüssel

Universal Torque Wrenches
Clés dynamométriques



Verwendung:
Zur Übertragung eines definierten Anzugsmomentes.
Application:
For the transfer of a defined torque.
Application:
Pour la transmission d'un couple de serrage défini.

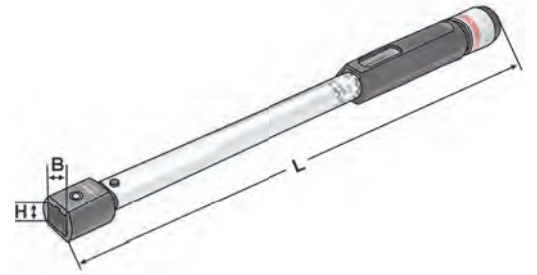

Bestell-Nr. Order no. Référence	Drehmoment Torque Couple	L	B	H
800.010	20 – 100 Nm	430	18	14
800.030	60 – 300 Nm	580	18	14

Schlüsseleinsätze für Spannmuttern System ER, mit Sechskant

Wrench inserts for clamping nuts ER-system, with hexagon
Inserts pour clés dynamométriques pour écrous de serrage système ER, avec hexagone

10



Verwendung:
Zur Übertragung eines definierten Anzugsmomentes.
Application:
For the transfer of a defined torque.
Application:
Pour la transmission d'un couple de serrage défini.

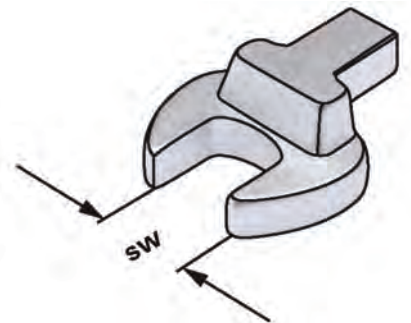

Bestell-Nr. Order no. Référence	Abmessung Size Dimension	SW
800.02.10	1 – 10 (ER 16)	25
800.02.10.2	1 – 10 (ER 16)	27

Schlüsseleinsätze für Spannmuttern System OZ



Wrench inserts for clamping nuts OZ-system

Inserts pour clés dynamométriques pour écrous de serrage système OZ



Verwendung:
Zur Übertragung eines definierten Anzugsmomentes.

Application:
For the transfer of a defined torque.

Application:
Pour la transmission d'un couple de serrage défini.

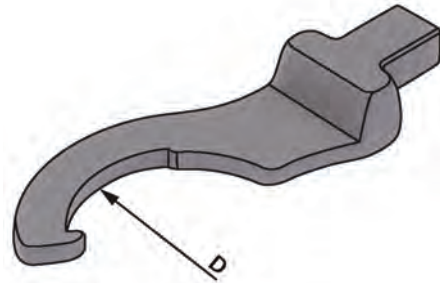

Bestell-Nr. Order no. Référence	Abmessung Size Dimension	D
800.01.16	2 – 16 (OZ 16)	40
800.01.25	2 – 25 (OZ 25)	58
800.01.32	3 – 32 (OZ 32)	68

Schlüsseleinsätze für Spannmuttern System ER

Wrench inserts for clamping nuts ER-system

Inserts pour clés dynamométriques pour écrous de serrage système ER



Verwendung:
Zur Übertragung eines definierten Anzugsmomentes.

Application:
For the transfer of a defined torque.

Application:
Pour la transmission d'un couple de serrage défini.

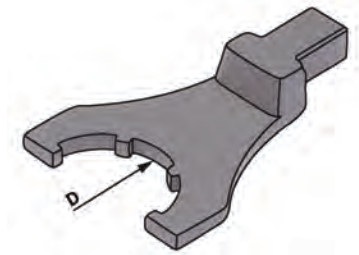

10

Bestell-Nr. Order no. Référence	Abmessung Size Dimension	D
800.02.10.1	1 – 10 (ER 16)	32
800.02.13	2 – 13 (ER 20)	35
800.02.16	2 – 16 (ER 25)	42
800.02.20	2 – 20 (ER 32)	50
800.02.26	2 – 26 (ER 40)	63



Schlüsseleinsätze für System HKS

Wrench inserts for system HKS

Inserts pour clés dynamométriques pour système HKS



Verwendung:

Zur Übertragung eines definierten Anzugsmomentes.

Application:

For the transfer of a defined torque.

Application:

Pour la transmission d'un couple de serrage défini.

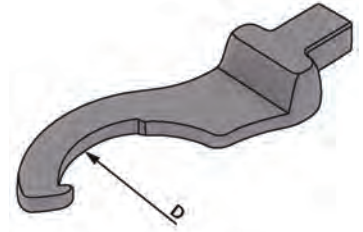

Bestell-Nr. Order no. Référence	Abmessung Size Dimension	D
800.64.20	HKS 20	50
800.64.32	HKS 25 + HKS 32	60

Schlüsseleinsätze für Anzugsbolzen

Wrench inserts for Pull studs

Inserts pour tirettes



Verwendung:

Zur Übertragung eines definierten Anzugsmomentes.

Application:

For the transfer of a defined torque.

Application:

Pour la transmission d'un couple de serrage défini.

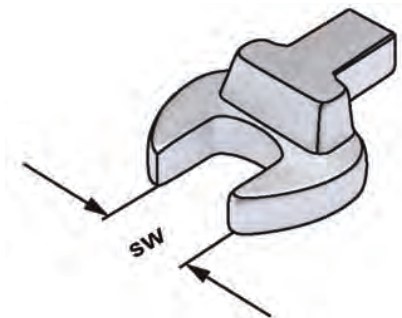

10

Bestell-Nr. Order no. Référence	Abmessung Size Dimension	SW
800.20.13	BT 30	13
800.20.14	SK 30	14
800.20.19	SK / BT 40	19
800.20.30	SK / BT 50	30

Wrenches DIN 1810 A for clamping nuts OZ-system
Clés à ergot DIN 1810 A pour écrous de serrage système OZ



Verwendung:
Für Spannmuttern System OZ.
Application:
For clamping nuts OZ-system.
Application:
Pour écrous de serrage système OZ.

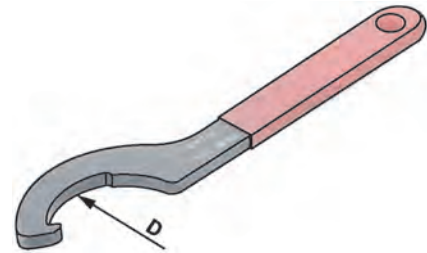

Bestell-Nr. Order no. Référence	Abmessung Size Dimension	D
01.16	2 – 16 (OZ 16)	40
01.25	2 – 25 (OZ 25)	58
01.32	3 – 32 (OZ 32)	68



Spannschlüssel für Spannmuttern System ER

Wrenches for clamping nuts ER-system
Clés de serrage pour écrous de serrage système ER



Verwendung:
Für Spannmuttern System ER.
Application:
For clamping nuts ER-system.
Application:
Pour écrous de serrage système ER.

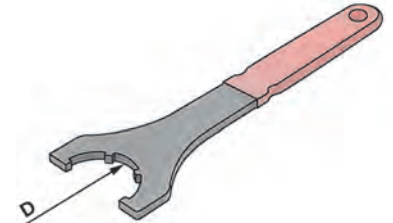

Bestell-Nr. Order no. Référence	Abmessung Size Dimension	D
02.10.1	1 – 10 (ER 16)	32
02.13	2 – 13 (ER 20)	35
02.16	2 – 16 (ER 25)	42
02.20	2 – 20 (ER 32)	50
02.26	2 – 26 (ER 40)	63

Spannschlüssel für Spannmuttern System ER

Wrenches for clamping nuts ER-system
Clés de serrage pour écrous de serrage système ER



Verwendung:
Für Spannmuttern System ER.
Application:
For clamping nuts ER-system.
Application:
Pour écrous de serrage système ER.

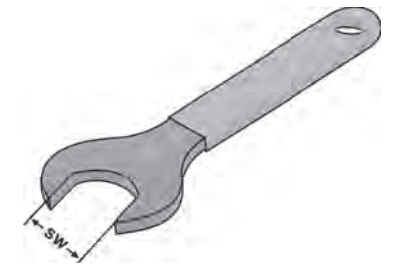

Bestell-Nr. Order no. Référence	Abmessung Size Dimension	D	SW
02.07	1 – 7 (ER 11)	19	17
02.10	1 – 10 (ER 16)	28	25
02.10.2	1 – 10 (ER 16)	30	27
02.13.1	2 – 13 (ER 20)	34	30

Für Sechskantmutter
For hexagonal clamping nut
Pour écrou hexagonal

Spannschlüssel für Spannmuttern System ER



Wrenches for clamping nuts ER-system

Clés de serrage pour écrous de serrage système ER



Verwendung:
Für Mini-Spannmuttern System ER.
Application:
For mini clamping nuts ER-system.
Application:
Pour écrous de serrage mini système ER.

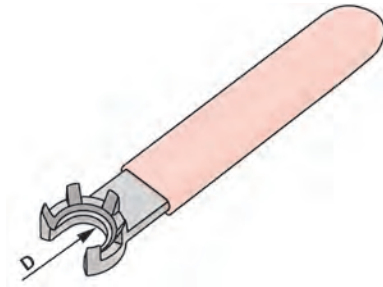

Bestell-Nr. Order no. Référence	Abmessung Size Dimension	D
02.07.3	1 – 7 (ER 11)	16
02.10.3	1 – 10 (ER 16)	22
02.13.3	2 – 13 (ER 20)	28
02.16.3	2 – 16 (ER 25)	37

Sechskantschlüssel

Hexagonal wrench

Clés hexagonale



Verwendung:
Für CNC Bohrfutter und Hydrodehnspannfutter.
Application:
For CNC drill chucks and hydraulic chucks.
Application:
Pour Mandrin de perçage CNC et mandrin expansibles hydrauliques.



Bestell-Nr. Order no. Référence	Abmessung Size Dimension	SW	L
T-4-100	4-100	4	100
T-5-100	5-100	5	100
T-6-100	6-100	6	100

10



Anzugsbolzen DIN 69872 A+B

Pull studs DIN 69872 A+B
Tirettes DIN 69872 A+B

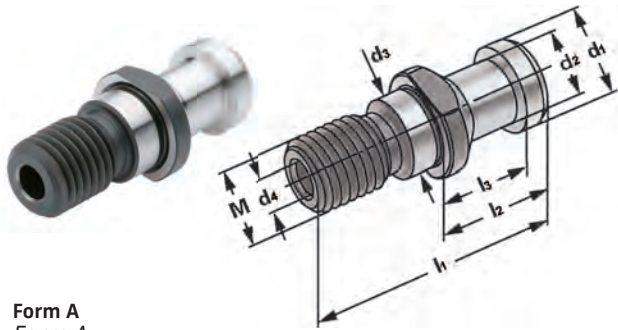

Form A
Form A
Forme A

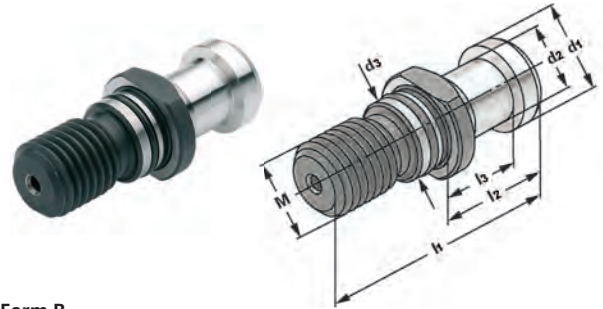

Form B
Form B
Forme B



Bestell-Nr. Order no. / Référence	M	l ₁	l ₂	l ₃	d ₁	d ₂	d ₃	d ₄
302.20.12	M12	44	24	19	13	9	13	3,0
402.20.16	M16	54	26	20	19	14	17	7,0
502.20.24	M24	74	34	25	28	21	25	11,5

Form A (mit Durchgangsbohrung, ohne O-Ring) DIN 69872 A
Form A (with drill through, without O-ring) DIN 69872 A
Forme A (percée, sans joint torique) DIN 69872 A

402.20.16.0	M16	54	26	20	19	14	17	7,0
502.20.24.0	M24	74	34	25	28	21	25	11,5

Form A (mit Durchgangsbohrung, inkl. O-Ring) DIN 69872 A
Form A (with drill through, incl. O-ring) DIN 69872 A
Forme A (percée, avec joint torique) DIN 69872 A

403.20.16	M16	54	26	20	19	14	17	-
503.20.24	M24	74	34	25	28	21	25	-

Form B (ohne Durchgangsbohrung, inkl. O-Ring) DIN 69872 B
Form B (sealed, incl. O-ring) DIN 69872 B
Forme B (étanche, avec joint torique) DIN 69872 B

10

Anzugsbolzen ähnlich DIN 69872 A, 3 mm verlängert

Pull studs similar to DIN 69872 A, lengthened by 3 mm
Tirettes ressemblant à DIN 69872 A, allongé par 3 mm



Bestell-Nr. Order no. / Référence	M	l ₁	l ₂	l ₃	d ₁	d ₂	d ₃	d ₄
402.20.16.21	M16	54	29	23	19	14	17	7,0

Form A (mit Durchgangsbohrung, inkl. O-Ring)
Form A (with drill through, incl. O-ring)
Forme A (percée, avec joint torique)



10.18



10.20

Sonderbolzen auf Anfrage kurzfristig lieferbar.
Special pull studs available within a short period upon request.
Tirettes spéciales livrables dans un délai court sur demande.



Anzugsbolzen ISO 7388



Pull studs ISO 7388
Tirettes ISO 7388

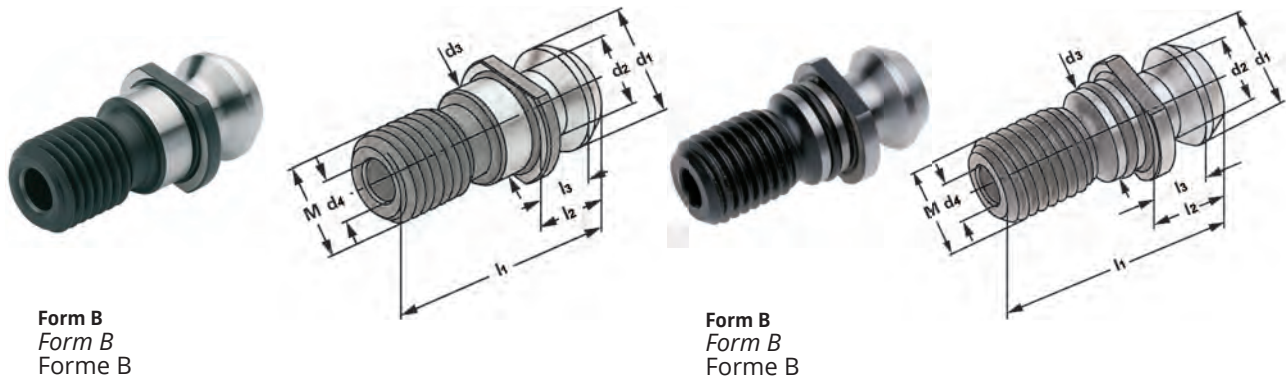

Form B
Form B
Forme B

Form B
Form B
Forme B



Bestell-Nr.								
Order no. / Référence	M	l ₁	l ₂	l ₃	d ₁	d ₂	d ₃	d ₄
404.20.16	M16	44,5	16,40	11,15	18,95	12,95	17	7,0
504.20.24	M24	65,5	25,55	17,95	29,10	19,60	25	11,5
Form II B (mit Durchgangsbohrung, ohne O-Ring) <i>Form II B (with drill through, without O-ring)</i> Forme II B (percée, sans joint torique)								
404.20.16.0	M16	44,5	16,40	11,15	18,95	12,95	17	7,0
504.20.24.0	M24	65,5	25,55	17,95	29,10	19,60	25	11,5
Form II B (mit Durchgangsbohrung, inkl. O-Ring) <i>Form II B (with drill through, incl. O-ring)</i> Forme II B (percée, avec joint torique)								
404.20.16.30	M16	44,5	16,40	11,15	18,95	12,95	17	-
504.20.24.30.0	M24	65,5	25,55	17,95	29,10	19,60	25	-
Form 7388 (ohne Durchgangsbohrung, inkl. O-Ring) <i>Form 7388 (sealed, incl. O-ring)</i> Forme 7388 (étanche, avec joint torique)								
504.20.24.30	M24	65,5	25,55	17,95	29,10	19,60	25	-
Form 7388 (ohne Durchgangsbohrung, ohne O-Ring) <i>Form 7388 (sealed, without O-ring)</i> Forme 7388 (étanche, sans joint torique)								

10

Anzugsbolzen ähnlich ISO 7388, 3 mm verlängert

Pull studs similar to ISO 7388, lengthened by 3 mm
Tirettes ressemblant à ISO 7388, allongé par 3 mm

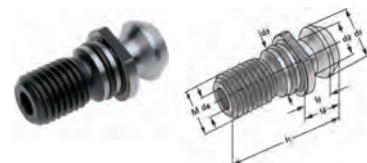

Bestell-Nr.								
Order no. / Référence	M	l ₁	l ₂	l ₃	d ₁	d ₂	d ₃	d ₄
404.20.16.20	M16	47,50	19,25	14,15	18,95	12,95	17,00	7,3
Mit Durchgangsbohrung, inkl. O-Ring <i>With drill through, incl. O-ring</i> Percée, avec joint torique								



Anzugsbolzen CAT metrisch

Pull studs CAT metric
Tirettes CAT métrique

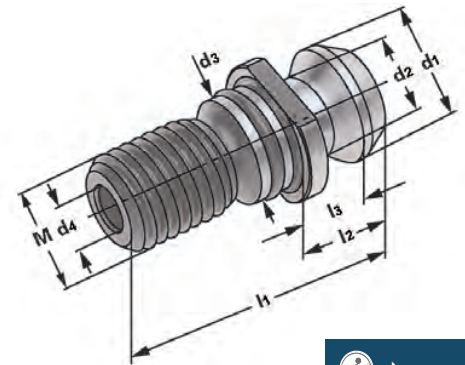

Bestell-Nr.

Order no. / Référence	M	l ₁	l ₂	l ₃	d ₁	d ₂	d ₃	d ₄
404.20.16.21	M16	41,26	16,26	11,18	18,80	12,45	17,00	7,0

Mit Durchgangsbohrung, inkl. O-Ring
With drill through, incl. O-ring
Percée, avec joint torique

504.20.24.21	M24	65,40	25,40	17,80	28,95	20,80	25,00	11,5
--------------	-----	-------	-------	-------	-------	-------	-------	------

SK 50 mit Freidrehung im Kopf für O-Ring
SK 50 with open head rotation for O-rings
SK 50 avec rotation libre du tête pour joints ronds

Anzugsbolzen CAT metrisch für Hochdruckkühlung

Pull studs CAT metric for high-pressure cooling
Tirettes CAT métrique pour refroidissement sous haut pression

10

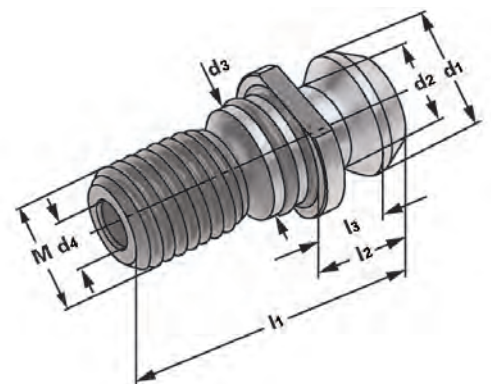

Bestell-Nr.

Order no. / Référence	M	l ₁	l ₂	l ₃	d ₁	d ₂	d ₃	d ₄
404.20.16.22	M16	41,26	16,26	11,18	18,80	12,45	17,00	7,0

504.20.24.22	M24	65,40	25,40	17,80	28,95	20,80	25,00	11,5
--------------	-----	-------	-------	-------	-------	-------	-------	------

Mit Durchgangsbohrung, inkl. O-Ringen in der Bohrung und am Bund
With drill through, incl. O-rings in the bore and the collar
Percée, avec joints toriques dans le perçage et à la collerette

Anzugsbolzen JIS B 6339 (MAS 403 BT)



Pull studs JIS B 6339 (MAS 403 BT)
Tirettes JIS B 6339 (MAS 403 BT)

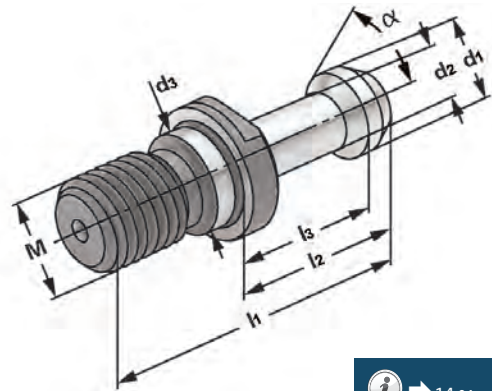

Bestell-Nr. Order no. / Référence	M	l ₁	l ₂	l ₃	d ₁	d ₂	d ₃
305.20.45	M12 - 45°	43	23	18	11	7	12,5
305.20.60	M12 - 60°	43	23	18	11	7	12,5
405.20.45	M16 - 45°	60	35	28	15	10	17,0
405.20.60	M16 - 60°	60	35	28	15	10	17,0
405.20.90	M16 - 90°	60	35	28	15	10	17,0
505.20.45	M24 - 45°	85	45	35	23	17	25,0
505.20.60	M24 - 60°	85	45	35	23	17	25,0
505.20.90	M24 - 90°	85	45	35	23	17	25,0

Ohne Durchgangsbohrung, ohne O-Ring
Sealed, without O-ring
Étanche, sans joint torique

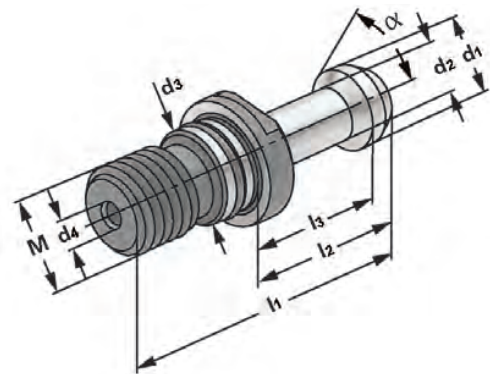

10

Bestell-Nr. Order no. / Référence	M	l ₁	l ₂	l ₃	d ₁	d ₂	d ₃	d ₄
306.20.45	M12 - 45°	43	23	18	11	7	12,5	2,5
306.20.60	M12 - 60°	43	23	18	11	7	12,5	2,5
406.20.45	M16 - 45°	60	35	28	15	10	17,0	4,0
406.20.60	M16 - 60°	60	35	28	15	10	17,0	4,0
406.20.90	M16 - 90°	60	35	28	15	10	17,0	4,0
506.20.45	M24 - 45°	85	45	35	23	17	25,0	6,0
506.20.60	M24 - 60°	85	45	35	23	17	25,0	6,0
506.20.90	M24 - 90°	85	45	35	23	17	25,0	6,0

Mit Durchgangsbohrung, inkl. O-Ring
With drill through, incl. O-ring
Percée, avec joint torique



Anzugsbolzen Haas ähnlich JIS B 6399 (MAS 403 BT), um 3 mm verkürzt

Pull studs Haas similar to JIS B 6399 (MAS 403 BT), shortened by 3 mm

Tirettes Haas ressemblant à JIS B 6399 (MAS 403 BT), raccourci par 3 mm

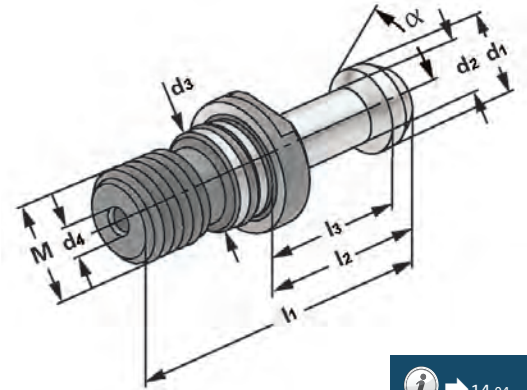

Bestell-Nr.								
Order no. / Référence	M	l_1	l_2	l_3	d_1	d_2	d_3	d_4
405.20.45.21	M16 – 45°	57	32	25	15	10	17	4,0
405.20.60.21	M16 – 60°	57	32	25	15	10	17	4,0
405.20.90.21	M16 – 90°	57	32	25	15	10	17	4,0

Mit Durchgangsbohrung, inkl. O-Ring
With drill through, incl. O-ring
 Percée, avec joint torique

Bestell-Nr.								
Order no. / Référence	M	l_1	l_2	l_3	d_1	d_2	d_3	d_4
406.20.45.21	M16 – 45°	57	32	25	15	10	17	
406.20.60.21	M16 – 60°	57	32	25	15	10	17	
406.20.90.21	M16 – 90°	57	32	25	15	10	17	

Ohne Durchgangsbohrung, inkl. O-Ring
Sealed, incl. O-ring
 Étanche, avec joint torique

Sonderbolzen auf Anfrage kurzfristig lieferbar.
Special pull studs available within a short period upon request.
 Tirettes spéciales livrables dans un délai court sur demande.



Anzugsbolzen DIN 2080 mit Ott-Ringnut



Pull studs DIN 2080 with Ott-groove
Tirettes DIN 2080 avec gorge Ott

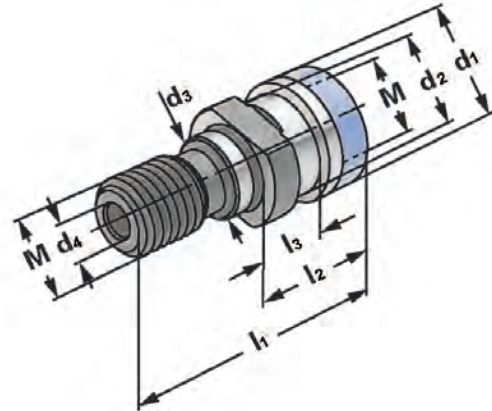

Bestell-Nr. Order no. / Référence	M	l ₁	l ₂	l ₃	d ₁	d ₂	d ₃	d ₄
401.20.16	M16	53,0	25,1	13,6	25,00	21,1	17	7,0
501.20.24	M24	65,1	25,1	13,3	39,60	32,0	25	7,0

Mit Innengewinde und Durchgangsbohrung
With internal thread and drill through
Avec filetage intérieur et perçage

Hinweis: Mit Kantenschutzring
Note: With protection ring
Observation: Avec bague de protection

Anzugsbolzen S 20 × 2 - Sägegewindebolzen für Deckel

Pull studs S 20 × 2
Tirettes S 20 × 2

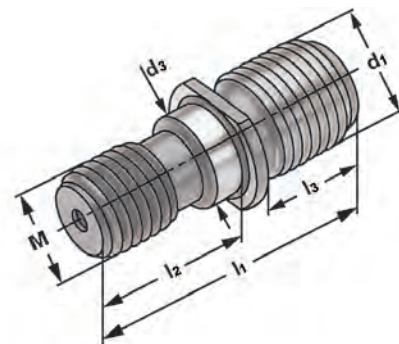

10

Bestell-Nr. Order no. / Référence	M	l ₁	l ₂	l ₃	d ₁	d ₃
401.20.16.S	M16	56,0	28,0	19,0	S 20 × 2	17,0

K Schnellwechsel-Einsätze ohne Sicherheitskupplung, Größe 1

Quick change adaptors without safety clutch, size 1
 Adaptateurs à changement rapide sans limiteur de couple, taille 1



Verwendung:
 Zur Spannung von Gewindebohrern.
 Für Rechts- und Linksgewinde. Standardausführung ohne Sicherheitskupplung.

Application:
 For mounting taps. For right-hand and left-hand threads. Standard type without safety clutch.

Application:
 Pour le serrage de tarauds. Pour taraudage à droite et à gauche. Modèle standard sans limiteur de couple.

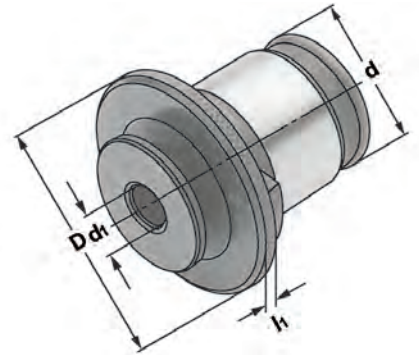

Bestell-Nr. Order no. Référence	D	d	l ₁	Schaft Shaft Queue d ₁	Vierkant Square Carré
16.01.3527	30	19	5	3,5	2,7
16.01.4534	30	19	5	4,5	3,4
16.01.43	30	19	5	4,0	3,0
16.01.649	30	19	5	6,0	4,9
16.01.755	30	19	5	7,0	5,5
16.01.862	30	19	5	8,0	6,2
16.01.97	30	19	5	9,0	7,0
16.01.108	30	19	5	10,0	8,0
16.01.119	30	19	5	11,0	9,0

Hinweis: Bei Adaptern ohne Sicherheitskupplung ist ein Austausch möglich, da nur Werkzeugschaft-Ø und Vierkant passend sein müssen.

Note: Quick change adaptors without safety clutch can be interchanged, because only the shaft diameters and the squares must fit.

Observation: On peut substituer les adaptateurs sans limiteur de couple, parce que seulement la queue et le carré doivent repérer.



Quick change adaptors with safety clutch, size 1

Adaptateurs à changement rapide avec limiteur de couple, taille 1



Verwendung:

Zur Spannung von Gewindebohrern.
Für Rechts- und Linksgewinde. Ausführung mit einstellbarer Sicherheitskupplung zur Vermeidung von Gewindebohrerbruch.

Application:

For mounting taps. For right-hand and left-hand threads. Type with adjustable safety clutch, which prevents the breaking of taps.

Application:

Pour le serrage de tarauds. Pour taraudage à droite et à gauche. Modèle avec limiteur de couple, qui prévient la casse des tarauds.

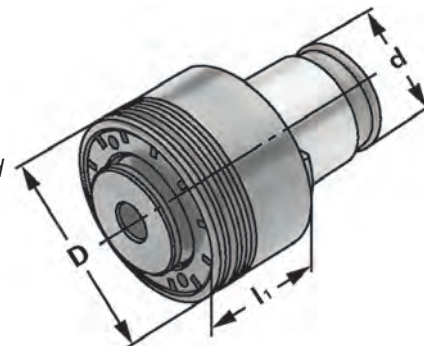

Bestell-Nr. Order no. Référence	D	d	l ₁	M	DIN	Schaft Shaft Queue d ₁	Vierkant Square Carré
16.11.335	32	19	25	M3	371	3,5	2,7
16.11.354	32	19	25	M3,5	371	4,0	3,0
16.11.445	32	19	25	M4	371	4,5	3,4
16.11.5649	32	19	25	M5	371	6,0	4,9
16.11.6649	32	19	25	M6	371	6,0	4,9
16.11.88	32	19	25	M8	371	8,0	6,2
16.11.107	32	19	25	M10	376	7,0	5,5
16.11.1010	32	19	25	M10	371	10,0	8,0
16.11.129	32	19	25	M12	376	9,0	7,0
16.11.14119	32	19	25	M14	376	11,0	9,0

Hinweis: Bei Adaptern mit Sicherheitskupplung wird das Drehmoment entsprechend der Gewindegröße vor Auslieferung eingestellt.

Note: Quick change adaptors with safety clutch are supplied with a predefined torque, corresponding to the sizes of the threads.

Observation: Les adaptateurs porte-tarauds à changement rapide avec limiteur de couple sont fournis avec un couple pré réglé, qui correspond aux tailles de filetages.





Schnellwechsel-Einsätze ohne Sicherheitskupplung, Größe 2

Quick change adaptors without safety clutch, size 2
Adaptateurs à changement rapide sans limiteur de couple, taille 2



Verwendung:

Zur Spannung von Gewindebohrern.
Für Rechts- und Linksgewinde. Standardausführung ohne Sicherheitskupplung.

Application:

For mounting taps. For right-hand and left-hand threads. Standard type without safety clutch.

Application:

Pour le serrage de tarauds. Pour taraudage à droite et à gauche. Modèle standard sans limiteur de couple.

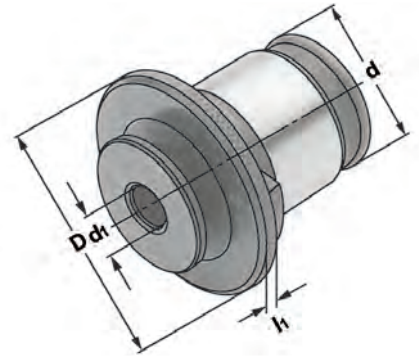

Bestell-Nr. Order no. Référence	D	d	l ₁	Schaft Shaft Queue d ₁	Vierkant Square Carré
16.02.649	48	31	6	6	4,9
16.02.755	48	31	6	7	5,5
16.02.862	48	31	6	8	6,2
16.02.97	48	31	6	9	7,0
16.02.108	48	31	6	10	8,0
16.02.119	48	31	6	11	9,0
16.02.129	48	31	6	12	9,0
16.02.1411	48	31	6	14	11,0
16.02.1612	48	31	6	16	12,0
16.02.18145	48	31	6	18	14,5

Hinweis: Bei Adaptern ohne Sicherheitskupplung ist ein Austausch möglich, da nur Werkzeugschaft-Ø und Vierkant passend sein müssen.

Note: Quick change adaptors without safety clutch can be interchanged, because only the shaft diameters and the squares must fit.

Observation: On peut substituer les adaptateurs sans limiteur de couple, parce que seulement la queue et le carré doivent repérer.



Quick change adaptors with safety clutch, size 2

Adaptateurs à changement rapide avec limiteur de couple, taille 2



Verwendung:

Zur Spannung von Gewindebohrern.
Für Rechts- und Linksgewinde. Ausführung mit einstellbarer Sicherheitskupplung zur Vermeidung von Gewindebohrerbruch.

Application:

For mounting taps. For right-hand and left-hand threads. Type with adjustable safety clutch, which prevents the breaking of taps.

Application:

Pour le serrage de tarauds. Pour taraudage à droite et à gauche. Modèle avec limiteur de couple, qui prévient la casse des tarauds.

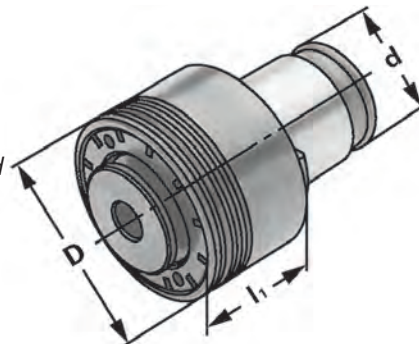

Bestell-Nr. Order no. Référence	D	d	l ₁	M	DIN	Schaft Shaft Queue d ₁	Vierkant Square Carré
16.12.5649	50	31	31	M5	371	6	4,9
16.12.6649	50	31	31	M6	371	6	4,9
16.12.88	50	31	31	M8	371	8	6,2
16.12.107	50	31	31	M10	376	7	5,5
16.12.1010	50	31	31	M10	371	10	8,0
16.12.129	50	31	31	M12	376	9	7,0
16.12.1411	50	31	31	M14	376	11	9,0
16.12.1612	50	31	31	M16	376	12	9,0
16.12.181411	50	31	31	M18	376	14	11,0
16.12.2016	50	31	31	M20	376	16	12,0
16.12.2218145	50	31	31	M22	376	18	14,5

Hinweis: Bei Adaptern mit Sicherheitskupplung wird das Drehmoment entsprechend der Gewindegröße vor Auslieferung eingestellt.

Note: Quick change adaptors with safety clutch are supplied with a predefined torque, corresponding to the sizes of the threads.

Observation: Les adaptateurs porte-tarauds à changement rapide avec limiteur de couple sont fournis avec un couple pré-réglé, qui correspond aux tailles de filetages.





Schnellwechsel-Einsätze ohne Sicherheitskupplung, Größe 3

Quick change adaptors without safety clutch, size 3
Adaptateurs à changement rapide sans limiteur de couple, taille 3



Verwendung:
Zur Spannung von Gewindebohrern.
Für Rechts- und Linksgewinde. Standardausführung ohne Sicherheitskupplung.

Application:
For mounting taps. For right-hand and left-hand threads. Standard type without safety clutch.

Application:
Pour le serrage de tarauds. Pour taraudage à droite et à gauche. Modèle standard sans limiteur de couple.

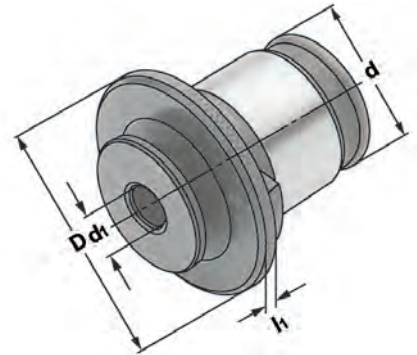

Bestell-Nr. Order no. Référence	D	d	l ₁	Schaft Shaft Queue d ₁	Vierkant Square Carré
16.03.119	63	48	6	11	9,0
16.03.129	63	48	6	12	9,0
16.03.1411	63	48	6	14	11,0
16.03.1612	63	48	6	16	12,0
16.03.18145	63	48	6	18	14,5
16.03.2016	63	48	6	20	16,0
16.03.2218	63	48	6	22	18,0
16.03.2520	63	48	6	25	20,0
16.03.2822	63	48	6	28	22,0

Hinweis: Bei Adaptern ohne Sicherheitskupplung ist ein Austausch möglich, da nur Werkzeugschaft-Ø und Vierkant passend sein müssen.

Note: Quick change adaptors without safety clutch can be interchanged, because only the shaft diameters and the squares must fit.

Observation: On peut substituer les adaptateurs sans limiteur de couple, parce que seulement la queue et le carré doivent repérer.



Quick change adaptors with safety clutch, size 3

Adaptateurs à changement rapide avec limiteur de couple, taille 3



Verwendung:

Zur Spannung von Gewindebohrern.
Für Rechts- und Linksgewinde. Ausführung mit einstellbarer Sicherheitskupplung zur Vermeidung von Gewindebohrerbruch.

Application:

For mounting taps. For right-hand and left-hand threads. Type with adjustable safety clutch, which prevents the breaking of taps.

Application:

Pour le serrage de tarauds. Pour taraudage à droite et à gauche. Modèle avec limiteur de couple, qui prévient la casse des tarauds.

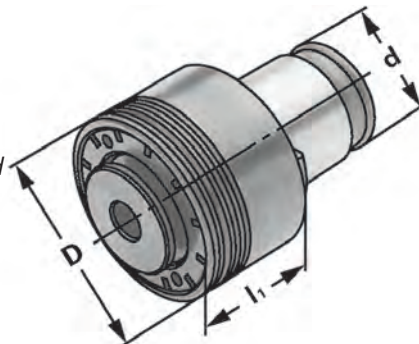

Bestell-Nr. Order no. Référence	D	d	l ₁	M	DIN	Schaft Shaft Queue d ₁	Vierkant Square Carré
16.13.14119	72	48	41	M14	376	11	9,0
16.13.16129	72	48	41	M16	376	12	9,0
16.13.181411	72	48	41	M18	376	14	11,0
16.13.201612	72	48	41	M20	376	16	12,0
16.13.2218145	72	48	41	M22	376	18	14,5
16.13.2418145	72	48	41	M24	376	18	14,5
16.13.272016	72	48	41	M27	376	20	16,0
16.13.302218	72	48	41	M30	376	22	18,0
16.13.332520	72	48	41	M33	376	25	20,0
16.13.362822	72	48	41	M36	376	28	22,0

Hinweis: Bei Adaptern mit Sicherheitskupplung wird das Drehmoment entsprechend der Gewindegröße vor Auslieferung eingestellt.

Note: Quick change adaptors with safety clutch are supplied with a predefined torque, corresponding to the sizes of the threads.

Observation: Les adaptateurs porte-tarauds à changement rapide avec limiteur de couple sont fournis avec un couple pré réglé, qui correspond aux tailles de filetages.





Reduzieradapter für Schnellwechsel-Einsätze

Reducing adaptors for quick change adaptors
Réductions pour adaptateurs à changement rapide



Verwendung:
Reduzieradapter zum Reduzieren der Größen 3 auf 2 bzw. 2 auf 1. Hiermit können die Spannbereiche nach unten erweitert werden.

Application:
Reducing adaptor for reducing size 3 to 2 and 2 to 1. In this way the clamping ranges can be extended to smaller sizes.

Application:
Pour la réduction des tailles 3 à 2 et 2 à 1. Il est ainsi possible d'élargir la plage inférieure de serrage.

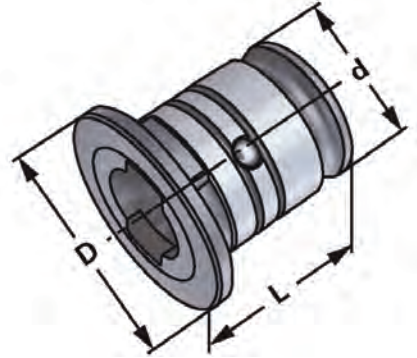

Bestell-Nr. Order no. Référence	Aufnahme workholder logement	Einsatz adaptor adapt.	D	d	L
16.00.0201	2	1	48	31	40,4
16.00.0302	3	2	59	48	62,6

Screw taps-shaft size
Pour taraud-taille de la tige

Schaftmaße Ø × □ Shaft diameter Ø × □ Diamètre de la queue Ø × □	DIN 352	DIN 5157	DIN 371	DIN 374	DIN 376
Ø 2,5 × 2,1 □	M1		M1	M3	M3,5
Ø 2,5 × 2,1 □	M1,1		M1,1	M3,5	
Ø 2,5 × 2,1 □	M1,2		M1,2		
Ø 2,5 × 2,1 □	M1,4		M1,4		
Ø 2,5 × 2,1 □	M1,6		M1,6		
Ø 2,5 × 2,1 □	M1,8		M1,8		
Ø 2,8 × 2,1 □	M2		M2	M4	M4
Ø 2,8 × 2,1 □	M2,2		M2,2		
Ø 2,8 × 2,1 □	M2,5		M2,5		
Ø 3,5 × 2,7 □	M3		M3	M5	M5
Ø 4 × 3 □	M3,5		M3,5		
Ø 4,5 × 3,4 □	M4		M4	M6	M6
Ø 6 × 4,9 □	M5		M5		
Ø 6 × 4,9 □	M6		M6		
Ø 6 × 4,9 □	M8			M8	M8
Ø 7 × 5,5 □	M10	G 1/8"		M10	M10
Ø 8 × 6,2 □			M8		
Ø 9 × 7 □	M12			M12	M12
Ø 10 × 8 □			M10		
Ø 11 × 9 □	M14	G 1/4"		M14	M14
Ø 12 × 9 □	M16	G 3/8"		M16	M16
Ø 14 × 11 □	M18			M18	M18
Ø 16 × 12 □	M20	G 1/2"		M20	M20
Ø 18 × 14,5 □	M22	G 5/8"		M22	M22
Ø 18 × 14,5 □	M24			M24	M24
Ø 20 × 16 □	M27	G 3/4"		M27	M27
Ø 22 × 18 □	M30	G 7/8"		M30	M30
Ø 25 × 20 □	M33	G 1		M33	M33
Ø 28 × 22 □	M36	G 1 1/8"		M36	M36
Ø 32 × 34 □	M39	G 1 1/4"		M39	M39
Ø 32 × 24 □	M42			M42	M42
Ø 36 × 29 □	M45	G 1 3/8"		M45	M45
Ø 36 × 29 □	M48	G 1 1/2"		M48	M48
Ø 36 × 29 □		G 1 3/4"			
Ø 36 × 29 □		G 2"			



Gewindeschneid-Schnellwechselfutter mit Längenausgleich auf Druck und Zug

für Zylinderschäfte DIN 1835 B+E

Quick change tapping chucks with length compensation on compression and expansion for tool shanks DIN 1835 B+E

Mandrins de taraudage à changement rapide avec compensation longitudinale à la compression et traction pour queues cylindriques DIN 1835 B+E



Verwendung:

Zur Aufnahme von Schnellwechsel-Ein-sätzen für Gewindebohrer.

Application:

For the chucking of Quick change taps for threading taps.

Application:

Pour le serrage d'adaptateurs porte-tarauts à changement rapide.

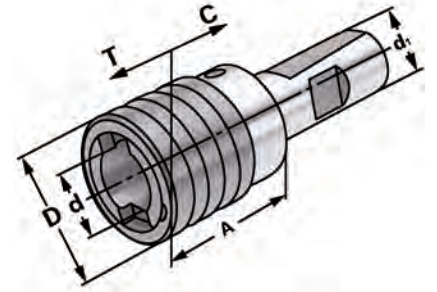

DIN 1835 B+E

Bestell-Nr. Order no. Référence	d ₁	Spannbereich Capacity Capacité	Größe Size Dimension	A	D	d	T	C
120.16.2012	20	M3 - M14	1	43	36	19	7	7
120.16.2020	20	M5 - M22	2	73	53	31	12	12
120.16.2512	25	M3 - M14	1	43	36	19	7	7
120.16.2520	25	M5 - M22	2	73	53	31	12	12
120.16.3220	32	M5 - M22	2	73	53	31	12	12

Hinweis: Für Bearbeitungszentren ohne Synchronspindel.
Note: On machining centres without synchronised spindles.
Observation: Sur centres d'usinage sans axe synchrone.

Ausführung: Mit seitlicher Spannfläche nach DIN 1835 Form B (Weldon) und DIN 1835 Form E (Whistle Notch).

Version: With flat according to DIN 1835 form B (Weldon) and inclined flat according to DIN 1835 form E (Whistle Notch).

Version: Avec queue cylindrique et avec méplat suivant DIN 1835 forme B (Weldon) et avec méplat incliné suivant DIN 1835 forme E (Whistle Notch).



für Spannzangen ISO 15488 (DIN 6499) System ER

Tapping chucks for synchronisation with tool shanks DIN 1835 B+E
for collets ISO 15488 (DIN 6499) ER-system

Mandrins de taraudage pour synchronisation avec queues cylindriques DIN 1835 B+E
pour pinces ISO 15488 (DIN 6499) système ER



Verwendung:
Für Bearbeitungszentren mit Synchronspindel.

Application:
For machining centres with synchronous spindle.

Application:
Pour centres d'usinage avec broche synchrone.

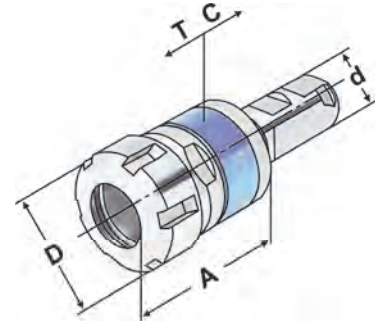

DIN 1835 B+E

$\nabla \leq 0,060$

Bestell-Nr. Order no. Référence	d	Spannbereich Capacity Capacité	A	D	T	C
120.16.2016*	20	M3 – M10 (ER 16) Mini	58	22	0,5	0,5
120.16.2025	20	M3 – M20 (ER 25)	63	42	0,5	0,5
120.16.2516*	25	M3 – M10 (ER 16) Mini	58	22	0,5	0,5
120.16.2525	25	M3 – M20 (ER 25)	63	42	0,5	0,5
120.16.2532	25	M4 – M27 (ER 32)	69	50	0,5	0,5
120.16.2540	25	M4 – M33 (ER 40)	109	63	0,5	0,5
120.16.3232	32	M4 – M27 (ER 32)	69	50	0,5	0,5
120.16.3240	32	M4 – M33 (ER 40)	109	63	0,5	0,5

*Mit Minimutter
*With mini nut
*Avec écrous-mini

- Hinweis:**
- Synchro-Gewindeschneidfutter kompensieren Synchronisationsfehler
 - Minimallängenausgleich in Druck- und Zugrichtung zwischen Synchronspindel und Gewindebohrer reduziert zu hohe Gewindeflankenreibungskräfte.
 - Reduziert eventuelle Axialkrafterhöhung während des Schneidzyklus auf ein Minimum.

- Note:**
- *Synchro tapping chucks compensate synchronisation errors*
 - *Minimal length compensation on compression and expansion balances very small pitch differences between synchro spindle and tap, which can cause high frictional forces on the thread flanks.*
 - *A possible increase of axial force during the tapping process is reduced to a minimum.*

- Observation:**
- Mandrins de taraudage version „synchro“ compensent les erreurs éventuelles de synchronisation
 - Compensation longitudinale minimale à la compression et traction entre la broche synchronisée et le taraud réduit la friction au niveau des flancs de filets.
 - Réduit au minimum les efforts éventuelles axiaux lors du cycle de taraudage.

Lieferumfang: Mit gewuchteter Spannmutter
Delivery: With balanced clamping nut
Livraison: Avec écrou de serrage équilibré

10





Gewindeschneid-Schnellwechselfutter DIN 69871 A mit Längenausgleich auf Druck und Zug im Holzkasten inkl. Einsätze mit Rutschkupplung

Quick-change tapping chucks DIN 69871 A with length compensati-
on in a wooden box incl. tapping collets with clutch

Mandrin de taraudage DIN 69871 A avec compensation longitu-
dinale dans coffret en bois incl. douilles avec limiteur de couple

Bestell Nr. Order no. / Réf.	Abmessung Size / Dimension	Größe Size / Taille	Stück Pcs.
402.16.12.SR	SK 40 - M3 / M14	Gr. 1	8
402.16.20.SR	SK 40 - M5 / M22	Gr. 2	10
502.16.12.SR	SK 50 - M3 / M14	Gr. 1	8
502.16.20.SR	SK 50 - M5 / M22	Gr. 2	10



Gewindeschneid-Schnellwechselfutter DIN 69871 A mit Längenausgleich auf Druck und Zug im Holzkasten inkl. Einsätze ohne Rutschkupplung

Quick-change tapping chucks DIN 69871 A with length compensati-
on in a wooden box incl. tapping collets without clutch

Mandrin de taraudage DIN 69871 A avec compensation longitu-
dinale dans coffret en bois incl. douilles sans limiteur de couple

Bestell Nr. Order no. / Réf.	Abmessung Size / Dimension	Größe Size / Taille	Stück Pcs.
402.16.12.S	SK 40 - M3 / M14	Gr. 1	7
402.16.20.S	SK 40 - M5 / M22	Gr. 2	9
502.16.12.S	SK 50 - M3 / M14	Gr. 1	7
502.16.20.S	SK 50 - M5 / M22	Gr. 2	9



Einsätze mit Rutschkupplung

Tapping collets with clutch
Douilles avec limiteur de couple

Abmessung Size / Dimension	Abmessung Size / Dimension
Gr. 1 M3 - 3,5 × 2,7 DIN 371	Gr. 2 M5 - 6 × 4,9 DIN 371
Gr. 1 M4 - 4,5 × 3,4 DIN 371	Gr. 2 M6 - 6 × 4,9 DIN 371
Gr. 1 M5 - 6 × 4,9 DIN 371	Gr. 2 M8 - 8 × 6,2 DIN 371
Gr. 1 M6 - 6 × 4,9 DIN 371	Gr. 2 M10 - 10 × 8 DIN 371
Gr. 1 M8 - 8 × 6,2 DIN 371	Gr. 2 M12 - 9 × 7 DIN 376
Gr. 1 M10 - 10 × 8 DIN 371	Gr. 2 M14 - 11 × 9 DIN 376
Gr. 1 M12 - 9 × 7 DIN 376	Gr. 2 M16 - 12 × 9 DIN 376
Gr. 1 M14 - 11 × 9 DIN 376	Gr. 2 M18 - 14 × 11 DIN 376
	Gr. 2 M20 - 16 × 12 DIN 376
	Gr. 2 M22 - 18 × 14,5 DIN 376



Einsätze ohne Rutschkupplung

Tapping collets without clutch
Douilles sans limiteur de couple

Abmessung Size / Dimension	Abmessung Size / Dimension
Gr. 1 3,5 × 2,7	Gr. 2 6 × 4,9
Gr. 1 4,5 × 3,4	Gr. 2 8 × 6,2
Gr. 1 6 × 4,9	Gr. 2 9 × 7
Gr. 1 8 × 6,2	Gr. 2 10 × 8
Gr. 1 9 × 7	Gr. 2 11 × 9
Gr. 1 10 × 8	Gr. 2 12 × 9
Gr. 1 11 × 9	Gr. 2 14 × 11
	Gr. 2 16 × 12
	Gr. 2 18 × 14,5



Gewindeschneid-Schnellwechselfutter MAS/BT (JIS B 6339) mit Längenausgleich auf Druck und Zug im Holzkasten inkl. Einsätze mit Rutschkupplung

Quick-change tapping chucks MAS/BT (JIS B 6339) with length compensation in a wooden box incl. tapping collets with clutch
 Mandrin de taraudage MAS/BT (JIS B 6339) avec compensation longitudinale dans coffret en bois incl. douilles avec limiteur de couple

Bestell Nr. <i>Order no. / Réf.</i>	Abmessung <i>Size / Dimension</i>	Größe <i>Size / Taille</i>	Stück <i>Pcs.</i>
405.16.12.SR	BT 40 - M3 / M14	Gr. 1	8
405.16.20.SR	BT 40 - M5 / M22	Gr. 2	10
505.16.12.SR	BT 50 - M3 / M14	Gr. 1	8
505.16.20.SR	BT 50 - M5 / M22	Gr. 2	10



Gewindeschneid-Schnellwechselfutter MAS/BT (JIS B 6339) mit Längenausgleich auf Druck und Zug im Holzkasten inkl. Einsätze ohne Rutschkupplung

Quick-change tapping chucks MAS/BT (JIS B 6339) with length compensation in a wooden box incl. tapping collets without clutch
 Mandrin de taraudage MAS/BT (JIS B 6339) avec compensation longitudinale dans coffret en bois incl. douilles sans limiteur de couple

Bestell Nr. <i>Order no. / Réf.</i>	Abmessung <i>Size / Dimension</i>	Größe <i>Size / Taille</i>	Stück <i>Pcs.</i>
405.16.12.S	BT 40 - M3 / M14	Gr. 1	7
405.16.20.S	BT 40 - M5 / M22	Gr. 2	9
505.16.12.S	BT 50 - M3 / M14	Gr. 1	7
505.16.20.S	BT 50 - M5 / M22	Gr. 2	9



Einsätze mit Rutschkupplung

Tapping collets with clutch
 Douilles avec limiteur de couple

Abmessung <i>Size / Dimension</i>
Gr. 1 M3 - 3,5 × 2,7 DIN 371
Gr. 1 M4 - 4,5 × 3,4 DIN 371
Gr. 1 M5 - 6 × 4,9 DIN 371
Gr. 1 M6 - 6 × 4,9 DIN 371
Gr. 1 M8 - 8 × 6,2 DIN 371
Gr. 1 M10 - 10 × 8 DIN 371
Gr. 1 M12 - 9 × 7 DIN 376
Gr. 1 M14 - 11 × 9 DIN 376

Abmessung <i>Size / Dimension</i>
Gr. 2 M5 - 6 × 4,9 DIN 371
Gr. 2 M6 - 6 × 4,9 DIN 371
Gr. 2 M8 - 8 × 6,2 DIN 371
Gr. 2 M10 - 10 × 8 DIN 371
Gr. 2 M12 - 9 × 7 DIN 376
Gr. 2 M14 - 11 × 9 DIN 376
Gr. 2 M16 - 12 × 9 DIN 376
Gr. 2 M18 - 14 × 11 DIN 376
Gr. 2 M20 - 16 × 12 DIN 376
Gr. 2 M22 - 18 × 14,5 DIN 376



Einsätze ohne Rutschkupplung

Tapping collets without clutch
 Douilles sans limiteur de couple

Abmessung <i>Size / Dimension</i>
Gr. 1 3,5 × 2,7
Gr. 1 4,5 × 3,4
Gr. 1 6 × 4,9
Gr. 1 8 × 6,2
Gr. 1 9 × 7
Gr. 1 10 × 8
Gr. 1 11 × 9

Abmessung <i>Size / Dimension</i>
Gr. 2 6 × 4,9
Gr. 2 8 × 6,2
Gr. 2 9 × 7
Gr. 2 10 × 8
Gr. 2 11 × 9
Gr. 2 12 × 9
Gr. 2 14 × 11
Gr. 2 16 × 12
Gr. 2 18 × 14,5



Gewindeschneid-Schnellwechselfutter DIN 69893 A mit Längenausgleich auf Druck und Zug im Holzkasten inkl. Einsätze mit Rutschkupplung

Quick-change tapping chucks DIN 69893 A with length compensation in a wooden box incl. tapping collets with clutch

Mandrin de taraudage DIN 69893 A avec compensation longitudinale dans coffret en bois incl. douilles avec limiteur de couple

Bestell Nr. Order no. / Réf.	Abmessung Size / Dimension	Größe Size / Taille	Stück Pcs.
A63.16.12.SR	HSK 63 - M3 / M14	Gr. 1	8
A63.16.20.SR	HSK 63 - M5 / M22	Gr. 2	10
A100.16.12.SR	HSK 100 - M3 / M14	Gr. 1	8
A100.16.20.SR	HSK 100 - M5 / M22	Gr. 2	10



Gewindeschneid-Schnellwechselfutter DIN 69893 A mit Längenausgleich auf Druck und Zug im Holzkasten inkl. Einsätze ohne Rutschkupplung

Quick-change tapping chucks DIN 69893 A with length compensation in a wooden box incl. tapping collets without clutch

Mandrin de taraudage DIN 69893 A avec compensation longitudinale dans coffret en bois incl. douilles sans limiteur de couple

Bestell Nr. Order no. / Réf.	Abmessung Size / Dimension	Größe Size / Taille	Stück Pcs.
A63.16.12.S	HSK 63 - M3 / M14	Gr. 1	7
A63.16.20.S	HSK 63 - M5 / M22	Gr. 2	9
A100.16.12.S	HSK 100 - M3 / M14	Gr. 1	7
A100.16.20.S	HSK 100 - M5 / M22	Gr. 2	9



Einsätze mit Rutschkupplung

Tapping collets with clutch
Douilles avec limiteur de couple

Abmessung Size / Dimension	Abmessung Size / Dimension
Gr. 1 M3 - 3,5 × 2,7 DIN 371	Gr. 2 M5 - 6 × 4,9 DIN 371
Gr. 1 M4 - 4,5 × 3,4 DIN 371	Gr. 2 M6 - 6 × 4,9 DIN 371
Gr. 1 M5 - 6 × 4,9 DIN 371	Gr. 2 M8 - 8 × 6,2 DIN 371
Gr. 1 M6 - 6 × 4,9 DIN 371	Gr. 2 M10 - 10 × 8 DIN 371
Gr. 1 M8 - 8 × 6,2 DIN 371	Gr. 2 M12 - 9 × 7 DIN 376
Gr. 1 M10 - 10 × 8 DIN 371	Gr. 2 M14 - 11 × 9 DIN 376
Gr. 1 M12 - 9 × 7 DIN 376	Gr. 2 M16 - 12 × 9 DIN 376
Gr. 1 M14 - 11 × 9 DIN 376	Gr. 2 M18 - 14 × 11 DIN 376
	Gr. 2 M20 - 16 × 12 DIN 376
	Gr. 2 M22 - 18 × 14,5 DIN 376



Einsätze ohne Rutschkupplung

Tapping collets without clutch
Douilles sans limiteur de couple

Abmessung Size / Dimension	Abmessung Size / Dimension
Gr. 1 3,5 × 2,7	Gr. 2 6 × 4,9
Gr. 1 4,5 × 3,4	Gr. 2 8 × 6,2
Gr. 1 6 × 4,9	Gr. 2 9 × 7
Gr. 1 8 × 6,2	Gr. 2 10 × 8
Gr. 1 9 × 7	Gr. 2 11 × 9
Gr. 1 10 × 8	Gr. 2 12 × 9
Gr. 1 11 × 9	Gr. 2 14 × 11
	Gr. 2 16 × 12
	Gr. 2 18 × 14,5



**Gewindeschneid-Schnellwechselfutter
DIN 69880 mit Längenausgleich
auf Druck und Zug im Holzkasten
inkl. Einsätze mit Rutschkupplung**

*Quick-change tapping chucks DIN 69880 with length compensation
in a wooden box incl. tapping collets with clutch*

*Mandrin de taraudage DIN 69880 avec compensation longitudinale
dans coffret en bois incl. douilles avec limiteur de couple*

Bestell Nr. <i>Order no. / Réf.</i>	Abmessung <i>Size / Dimension</i>	Größe <i>Size / Taille</i>	Stück <i>Pcs.</i>
309.16.12.SR	VDI 30 - M3 / M14	Gr. 1	8
309.16.20.SR	VDI 30 - M5 / M22	Gr. 2	10
409.16.12.SR	VDI 40 - M3 / M14	Gr. 1	8
409.16.20.SR	VDI 40 - M5 / M22	Gr. 2	10



**Gewindeschneid-Schnellwechselfutter
DIN 69880 mit Längenausgleich
auf Druck und Zug im Holzkasten
inkl. Einsätze ohne Rutschkupplung**

*Quick-change tapping chucks DIN 69880 with length compensation in a
wooden box incl. tapping collets without clutch*

*Mandrin de taraudage DIN 69880 avec compensation longitudinale
dans coffret en bois incl. douilles sans limiteur de couple*

Bestell Nr. <i>Order no. / Réf.</i>	Abmessung <i>Size / Dimension</i>	Größe <i>Size / Taille</i>	Stück <i>Pcs.</i>
309.16.12.S	VDI 30 - M3 / M14	Gr. 1	7
309.16.20.S	VDI 30 - M5 / M22	Gr. 2	9
409.16.12.S	VDI 40 - M3 / M14	Gr. 1	7
409.16.20.S	VDI 40 - M5 / M22	Gr. 2	9



Einsätze mit Rutschkupplung

*Tapping collets with clutch
Douilles avec limiteur de couple*

Abmessung <i>Size / Dimension</i>	Abmessung <i>Size / Dimension</i>
Gr. 1 M3 - 3,5 × 2,7 DIN 371	Gr. 2 M5 - 6 × 4,9 DIN 371
Gr. 1 M4 - 4,5 × 3,4 DIN 371	Gr. 2 M6 - 6 × 4,9 DIN 371
Gr. 1 M5 - 6 × 4,9 DIN 371	Gr. 2 M8 - 8 × 6,2 DIN 371
Gr. 1 M6 - 6 × 4,9 DIN 371	Gr. 2 M10 - 10 × 8 DIN 371
Gr. 1 M8 - 8 × 6,2 DIN 371	Gr. 2 M12 - 9 × 7 DIN 376
Gr. 1 M10 - 10 × 8 DIN 371	Gr. 2 M14 - 11 × 9 DIN 376
Gr. 1 M12 - 9 × 7 DIN 376	Gr. 2 M16 - 12 × 9 DIN 376
Gr. 1 M14 - 11 × 9 DIN 376	Gr. 2 M18 - 14 × 11 DIN 376
	Gr. 2 M20 - 16 × 12 DIN 376
	Gr. 2 M22 - 18 × 14,5 DIN 376



Einsätze ohne Rutschkupplung

*Tapping collets without clutch
Douilles sans limiteur de couple*

Abmessung <i>Size / Dimension</i>	Abmessung <i>Size / Dimension</i>
Gr. 1 3,5 × 2,7	Gr. 2 6 × 4,9
Gr. 1 4,5 × 3,4	Gr. 2 8 × 6,2
Gr. 1 6 × 4,9	Gr. 2 9 × 7
Gr. 1 8 × 6,2	Gr. 2 10 × 8
Gr. 1 9 × 7	Gr. 2 11 × 9
Gr. 1 10 × 8	Gr. 2 12 × 9
Gr. 1 11 × 9	Gr. 2 14 × 11
	Gr. 2 16 × 12
	Gr. 2 18 × 14,5



Gewindeschneid-Schnellwechselfutter DIN 228-1B mit Längenausgleich auf Druck und Zug im Holzkasten inkl. Einsätze mit Rutschkupplung

Quick-change tapping chucks DIN 228-1B with length compensation in a wooden box incl. tapping collets with clutch

Mandrin de taraudage DIN 228-1B avec compensation longitudinale dans coffret en bois incl. douilles avec limiteur de couple

Bestell Nr. Order no. / Réf.	Abmessung Size / Dimension	Größe Size/ Taille	Stück Pcs.
107.16.212.SR	MK 2 - M3 / M14	Gr. 1	8
107.16.320.SR	MK 3 - M5 / M22	Gr. 2	10



Gewindeschneid-Schnellwechselfutter DIN 228-1B mit Längenausgleich auf Druck und Zug im Holzkasten inkl. Einsätze ohne Rutschkupplung

Quick-change tapping chucks DIN 228-1B with length compensation in a wooden box incl. tapping collets without clutch

Mandrin de taraudage DIN 228-1B avec compensation longitudinale dans coffret en bois incl. douilles sans limiteur de couple

Bestell Nr. Order no. / Réf.	Abmessung Size / Dimension	Größe Size/ Taille	Stück Pcs.
107.16.212.S	MK 2 - M3 / M14	Gr. 1	7
107.16.320.S	MK 3 - M5 / M22	Gr. 2	9



Einsätze mit Rutschkupplung

Tapping collets with clutch
Douilles avec limiteur de couple

Abmessung Size / Dimension	Abmessung Size / Dimension
Gr. 1 M3 - 3,5 × 2,7 DIN 371	Gr. 2 M5 - 6 × 4,9 DIN 371
Gr. 1 M4 - 4,5 × 3,4 DIN 371	Gr. 2 M6 - 6 × 4,9 DIN 371
Gr. 1 M5 - 6 × 4,9 DIN 371	Gr. 2 M8 - 8 × 6,2 DIN 371
Gr. 1 M6 - 6 × 4,9 DIN 371	Gr. 2 M10 - 10 × 8 DIN 371
Gr. 1 M8 - 8 × 6,2 DIN 371	Gr. 2 M12 - 9 × 7 DIN 376
Gr. 1 M10 - 10 × 8 DIN 371	Gr. 2 M14 - 11 × 9 DIN 376
Gr. 1 M12 - 9 × 7 DIN 376	Gr. 2 M16 - 12 × 9 DIN 376
Gr. 1 M14 - 11 × 9 DIN 376	Gr. 2 M18 - 14 × 11 DIN 376
	Gr. 2 M20 - 16 × 12 DIN 376
	Gr. 2 M22 - 18 × 14,5 DIN 376



Einsätze ohne Rutschkupplung

Tapping collets without clutch
Douilles sans limiteur de couple

Abmessung Size / Dimension	Abmessung Size / Dimension
Gr. 1 3,5 × 2,7	Gr. 2 6 × 4,9
Gr. 1 4,5 × 3,4	Gr. 2 8 × 6,2
Gr. 1 6 × 4,9	Gr. 2 9 × 7
Gr. 1 8 × 6,2	Gr. 2 10 × 8
Gr. 1 9 × 7	Gr. 2 11 × 9
Gr. 1 10 × 8	Gr. 2 12 × 9
Gr. 1 11 × 9	Gr. 2 14 × 11
	Gr. 2 16 × 12
	Gr. 2 18 × 14,5



**Gewindeschneid-Schnellwechselfutter
Zylinderschaft DIN 1835 B+E
mit Längenausgleich auf Druck und Zug
im Holzkasten inkl. Einsätze mit Rutschkupplung**
*Quick-change tapping chucks straight shank DIN 1835 B+E with
length compensation in a wooden box incl. tapping collets with clutch*
Mandrin de taraudage pour queues cylindriques straight shank DIN 1835
B+E avec compensation longitudinale dans coffret en bois incl. douilles
avec limiteur de couple

Bestell Nr. <i>Order no. / Réf.</i>	Abmessung <i>Size / Dimension</i>	Größe <i>Size/ Taille</i>	Stück <i>Pcs.</i>
120.16.2012.SR	20 - M3 / M14	Gr. 1	8
120.16.2020.SR	20 - M5 / M22	Gr. 2	10



**Gewindeschneid-Schnellwechselfutter
Zylinderschaft DIN 1835 B+E mit Längenausgleich
auf Druck und Zug im Holzkasten
inkl. Einsätze ohne Rutschkupplung**
*Quick-change tapping chucks straight shank DIN 1835 B+E with length com-
pensation in a wooden box incl. tapping collets without clutch*
Mandrin de taraudage pour queues cylindriques straight shank
DIN 1835 B+E avec compensation longitudinale dans coffret en bois incl.
douilles sans limiteur de couple

Bestell Nr. <i>Order no. / Réf.</i>	Abmessung <i>Size / Dimension</i>	Größe <i>Size/ Taille</i>	Stück <i>Pcs.</i>
120.16.2012.S	20 - M3 / M14	Gr. 1	8
120.16.2020.S	20 - M5 / M22	Gr. 2	10



Einsätze mit Rutschkupplung

Tapping collets with clutch
Douilles avec limiteur de couple

Abmessung <i>Size / Dimension</i>
Gr. 1 M3 - 3,5 × 2,7 DIN 371
Gr. 1 M4 - 4,5 × 3,4 DIN 371
Gr. 1 M5 - 6 × 4,9 DIN 371
Gr. 1 M6 - 6 × 4,9 DIN 371
Gr. 1 M8 - 8 × 6,2 DIN 371
Gr. 1 M10 - 10 × 8 DIN 371
Gr. 1 M12 - 9 × 7 DIN 376
Gr. 1 M14 - 11 × 9 DIN 376

Abmessung <i>Size / Dimension</i>
Gr. 2 M5 - 6 × 4,9 DIN 371
Gr. 2 M6 - 6 × 4,9 DIN 371
Gr. 2 M8 - 8 × 6,2 DIN 371
Gr. 2 M10 - 10 × 8 DIN 371
Gr. 2 M12 - 9 × 7 DIN 376
Gr. 2 M14 - 11 × 9 DIN 376
Gr. 2 M16 - 12 × 9 DIN 376
Gr. 2 M18 - 14 × 11 DIN 376
Gr. 2 M20 - 16 × 12 DIN 376
Gr. 2 M22 - 18 × 14,5 DIN 376



Einsätze ohne Rutschkupplung

Tapping collets without clutch
Douilles sans limiteur de couple

Abmessung <i>Size / Dimension</i>
Gr. 1 3,5 × 2,7
Gr. 1 4,5 × 3,4
Gr. 1 6 × 4,9
Gr. 1 8 × 6,2
Gr. 1 9 × 7
Gr. 1 10 × 8
Gr. 1 11 × 9

Abmessung <i>Size / Dimension</i>
Gr. 2 6 × 4,9
Gr. 2 8 × 6,2
Gr. 2 9 × 7
Gr. 2 10 × 8
Gr. 2 11 × 9
Gr. 2 12 × 9
Gr. 2 14 × 11
Gr. 2 16 × 12
Gr. 2 18 × 14,5



Gewindebohrer-Spannhülsen für Fräseraufnahmen DIN 1835 B

mit Schnellwechsel-Kupplung

Clamping sleeves for taps in end mill holders DIN 1835 B with quick change adaptor

Douilles de serrage à changement rapide pour tarauds dans des porte-fraises DIN 1835 B



Verwendung:

Für Maschinen mit steigungssynchronem Vorschub. Zur verkehrsicheren Spannung von Gewindebohrern in Fräseraufnahmen nach DIN 1835 B

Application:

For machines with rigid tapping. For safe clamping of taps in end mill holders according to DIN 1835 B

Application:

Pour machines avec broche synchronisée. Pour le serrage stable de tarauds dans des attachements porte-fraises suivant DIN 1835 B

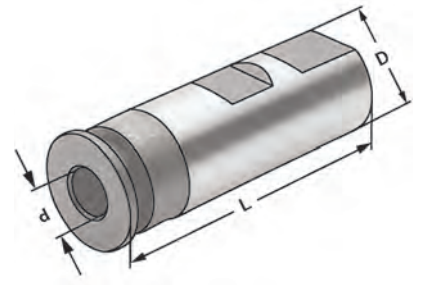

Bestell-Nr. Order no. Référence	D	d	Schaft Shaft Queue	Vierkant Square Carré	L
16.16.3527	16		3,5	2,7	56,0
16.16.4030	16		4,0	3,0	56,0
16.16.4534	16		4,5	3,4	56,0
16.16.649	16		6,0	4,9	56,0
16.20.4534	20		4,5	3,4	58,0
16.20.649	20		6,0	4,9	58,0
16.20.755	20		7,0	5,5	58,0
16.20.862	20		8,0	6,2	58,0
16.20.97	20		9,0	7,0	58,0
16.20.108	20		10,0	8,0	58,0
16.25.4534	25		4,5	3,4	66,0
16.25.649	25		6,0	4,9	66,0
16.25.755	25		7,0	5,5	66,0
16.25.862	25		8,0	6,2	66,0
16.25.97	25		9,0	7,0	66,0
16.25.108	25		10,0	8,0	66,0
16.25.119	25		11,0	9,0	66,0
16.25.129	25		12,0	9,0	66,0
16.32.649	32		6,0	4,9	70,0
16.32.755	32		7,0	5,5	70,0
16.32.862	32		8,0	6,2	70,0
16.32.97	32		9,0	7,0	70,0
16.32.108	32		10,0	8,0	70,0
16.32.119	32		11,0	9,0	70,0
16.32.129	32		12,0	9,0	70,0
16.32.1411	32		14,0	11,0	70,0
16.32.1612	32		16,0	12,0	70,0
16.32.18145	32		18,0	14,5	70,0

Clamping sleeves for taps in end mill holders DIN 1835 B
 Douilles de serrage pour tarauds dans des porte-fraises DIN 1835 B



Verwendung:
 Für Maschinen mit steigungssynchronem Vorschub. Zur verdrehsicheren Spannung von Gewindebohrern in Fräseraufnahmen nach DIN 1835 B.

Application:
 For machines with rigid tapping. For safe clamping of taps in end mill holders according to DIN 1835 B.

Application:
 Pour machines avec broche synchronisée. Pour le serrage stable de tarauds dans des porte-fraises suivant DIN 1835 B.

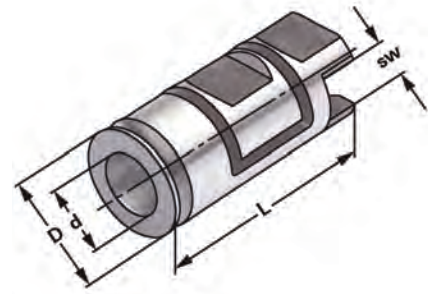

Bestell-Nr. Order no. Référence	D	d Schaft Shaft Queue	Vierkant Square Carré sw	L
704.04.0825	8	2,5	2,1	36
704.04.0828	8	2,8	2,1	36
704.04.1035	10	3,5	2,7	40
704.04.1040	10	4,0	3,0	40
704.04.1045	10	4,5	3,4	40
704.04.1260	12	6,0	4,9	45
704.04.1470	14	7,0	5,5	45
704.04.1480	14	8,0	6,2	48
704.04.1690	16	9,0	7,0	48
704.04.1610	16	10,0	8,0	48
704.04.1811	18	11,0	9,0	50
704.04.2012	20	12,0	9,0	50
704.04.2514	25	14,0	11,0	56
704.04.2516	25	16,0	12,0	56
704.04.3216	32	16,0	14,5	60
704.04.3218	32	18,0	14,5	60
704.04.3220	32	20,0	16,0	60
704.04.3222	32	22,0	18,0	60
704.04.4025	40	25,0	20,0	70
704.04.4028	40	28,0	22,0	70
704.04.5032	50	32,0	24,0	81
704.04.5036	50	36,0	29,0	81
704.04.5040	50	40,0	32,0	81



Fräseranzugschrauben DIN 6367

Retaining screws DIN 6367
Vis de serrage DIN 6367



Verwendung:
Fräseranzugsschraube zum Befestigen von Aufsteckfräsern.
Application:
Retaining screw for mounting of face mills arbors.
Application:
Vis de serrage pour la fixation de fraises.

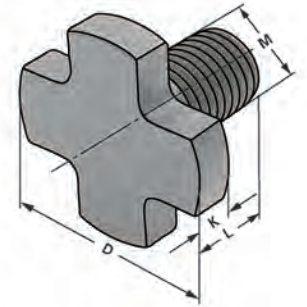

Bestell-Nr. Order no. Référence	Abmessung Size Dimension	M	D	K	L
102.10.16	16	M8	20	6	16
102.10.22	22	M10	28	7	18
102.10.27	27	M12	35	8	22
102.10.32	32	M16	42	9	26
102.10.40	40	M20	52	10	30
102.10.50	50	M24	63	12	36
102.10.60	60	M30	75	14	45

Fräseranzugschrauben DIN 6367 durchbohrt für Kühlmittelzufuhr

Retaining screws DIN 6367 with drill through for coolant
Vis de serrage DIN 6367 percée pour l'arrosage



Verwendung:
Fräseranzugsschraube zum Befestigen von Aufsteckfräsern.
Application:
Retaining screw for mounting of face mills arbors.
Application:
Vis de serrage pour la fixation de fraises.

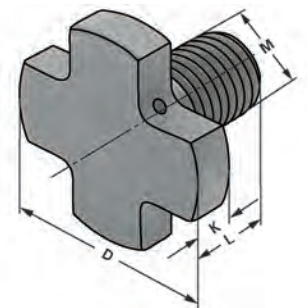

Bestell-Nr. Order no. Référence	Abmessung Size Dimension	M	D	K	L
102.11.16	16	M8	20	6	16
102.11.22	22	M10	28	7	18
102.11.27	27	M12	35	8	22
102.11.32	32	M16	42	9	26
102.11.40	40	M20	52	10	30
102.11.50	50	M24	63	12	36
102.11.60	60	M30	75	14	45

Driving key for shell mill holder Tasseaux pour porte-fraise à trou lisse



Verwendung:
Mitnehmersteine für Aufsteckfräser-
dorne PSK.

Application:
Drive Keys for shell end mill arbors .

Application:
Tenons d'entraînement pour mandrins
porte-fraise.

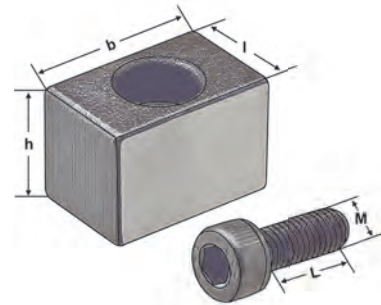

Bestell-Nr. Order no. Référence	l	b	h	M	L
101.11.16	8	10	8	M3	12
101.11.22	10	11	11	M4	12
101.11.27	10	14,5	12	M4	16
101.11.32	14	22	14	M5	14
101.11.40	16	22,5	16	M5	14
101.11.60	25,4	32,7	25,4	M12	25

Zylinderschrauben für Quernut-Aufsteckdorne DIN 912

Hexagon Socket Head Cap Screws DIN 912 Vis tête cylindrique DIN 912



Verwendung:
Fräseranzugsschraube zum Befestigen
von Aufsteckfräsern.

Application:
*Retaining screw for mounting of face mills
arbors.*

Application:
Vis de serrage pour la fixation de fraises.

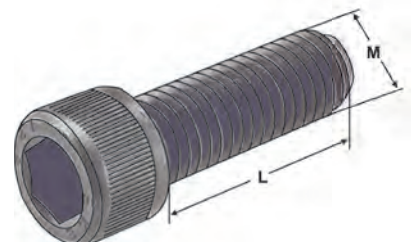

Bestell-Nr. Order no. Référence	Abmessung Size Dimension	M	L
102.10.161	16	M8	16
102.10.221	22	M10	25
102.10.271	27	M12	35
102.10.321	32	M16	35
102.10.401	40	M20	40

10



Spannschlüssel DIN 6368 für Aufsteckdorne

Wrenches DIN 6368 for shell arbors

Clés de serrage DIN 6368 pour broches creuses



Verwendung:

Für Fräseranzugsschraube DIN 6367.

Application:

For retaining screw DIN 6367.

Application:

Pour vis de fixation DIN 6367.

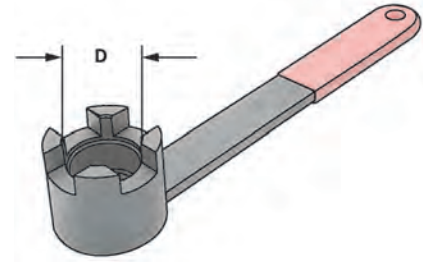

Bestell-Nr.
Order no.
Référence

D

10.16	16 / M8
10.22	22 / M10
10.27	27 / M12
10.32	32 / M16
10.40	40 / M20
10.50	50 / M24
10.60	60 / M30

Feather keys
Ressort de passage



Verwendung:
Für Kombi-Aufsteckfräserdorne DIN 6358.
Application:
For combi shell mill holders DIN 6358.
Application:
Pour porte-fraises à double usage DIN 6358.

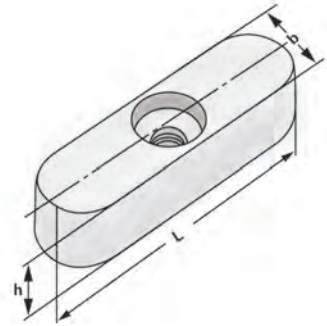

Bestell-Nr. Order no. Référence	h	b	L
101.10.16K	4	6	20
101.10.22K	6	6	25
101.10.27K	7	7	25
101.10.32K	7	8	28
101.10.40K	8	10	32

Mitnehmerringe DIN 6366

Clutch drive rings DIN 6366
Bagues d'entraînement DIN 6366



Verwendung:
Für Kombi-Aufsteckfräserdorne DIN 6358.
Application:
For combi shell mill holders DIN 6358.
Application:
Pour porte-fraises à double usage DIN 6358.

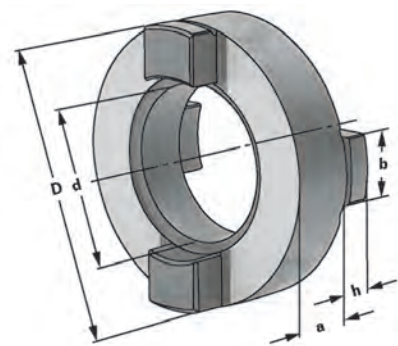

Bestell-Nr. Order no. Référence	d	D	a	b	h
101.10.16	16	32	10	8	5
101.10.22	22	40	12	10	5,6
101.10.27	27	46	12	12	6,3
101.10.32	32	55	14	14	7
101.10.40	40	68	14	16	8



Spannschrauben für Weldon Spannfutter DIN 1835 B

Clamping screws for Weldon chucks DIN 1835 B
Vis de serrage pour mandrins Weldon DIN 1835 B



Verwendung:
Für Fräseraufnahmen DIN 6359 für
Zylinderschäfte DIN 1835-B

Application:
End mill holders DIN 6359 for Weldon
type end mills DIN 1835-B

Application:
Porte-fraises DIN 6359 pour queues
cylindriques Weldon DIN 1835-B

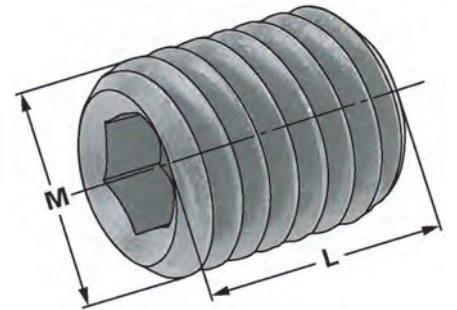

Bestell-Nr. Order no. Référence	M	L	für Durchmesser for diameter pour diamètre
101.04.06	M6	10	6
101.04.08	M8	10	8
101.04.10	M10	12	10
101.04.12	M12	16	12+14
101.04.16	M14	16	16+18
101.04.20	M16	16	20
101.04.25	M18 × 2	20	25
101.04.32	M20 × 2 × 20	20	32
101.04.40	M20 × 2 × 25	25	40

Spannschrauben für Weldon Spannfutter DIN 1835 B kurze Ausführung

Clamping screws for Weldon chucks DIN 1835 B short version
Vis de serrage pour mandrins Weldon DIN 1835 B version courte

10



Verwendung:
Für Fräseraufnahmen DIN 6359 für Zylinderschäfte DIN 1835-B

Application:
End mill holders DIN 6359 for Weldon type
end mills DIN 1835-B

Application:
Porte-fraises DIN 6359 pour queues
cylindriques Weldon DIN 1835-B

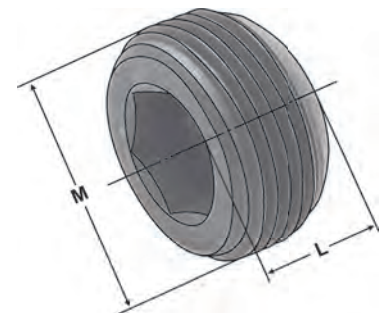

Bestell-Nr. Order no. Référence	M	L	für Artikelnummer for article number pour référence
101.04.16	M14	16	403.04.16.0 406.04.16.0
101.04.201	M16x1	8	403.04.20.0 + 403.04.25.0 + 403.04.32.0 406.04.20.0 + 406.04.25.0 + 406.04.32.0
101.04.202	M16x1	10	403.04.20.0 + 403.04.25.0 + 403.04.25.0 406.04.20.0 + 406.04.25.0 + 406.04.32.0
101.04.203	M16x1	12	403.04.32.0 + 406.04.32.0

Verstellschrauben für Weldon Whistle Notch DIN 1835 E



Adjusting Screws for Weldon chucks whistle notch DIN 1835 E
 Vis de réglage pour mandrins Weldon whistle notch DIN 1835 E



Verwendung:
 Zur Längeneinstellung des Schneidwerkzeugs
Application:
 For length adjustment of cutting tools
Application:
 Pour le réglage de la longueur de l'outil de coupe

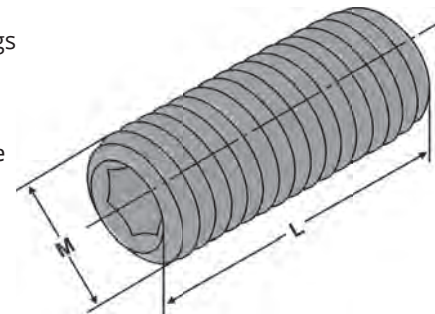

Bestell-Nr. Order no. Référence	M	L	für Durchmesser for diameter pour diamètre
102.05.06	M5x0,8	30	6
102.05.08	M6x1,0	30	8
102.05.10	M8x1,25	30	10
102.05.12	M10x1,5	30	12+14
102.05.16	M12x1,75	30	16+18
102.05.20	M16x2,0	30	20
102.05.25	M20x2,5	25	25+32+40

Verstellschrauben für Spannfutter

Adjusting Screws for collet chucks
 Vis de réglage pour mandrin de serrage



Verwendung:
 Zur Längeneinstellung des Schneidwerkzeugs
Application:
 For length adjustment of cutting tools
Application:
 Pour le réglage de la longueur de l'outil de coupe

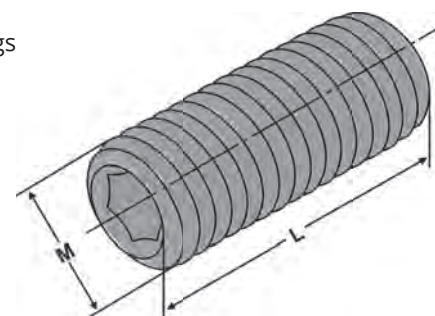

10

Bestell-Nr. Order no. Référence	M	L
101.02.05	M10 x 1,5 (ER16)	20
101.02.10	M12 x 1,75 (ER20)	20
101.02.15	M16 x 2,0 (ER25 + ER32 + ER40)	20



Spannschrauben für E1 Bohrerhalter

Clamping screws for E1 boring holders
Vis de serrage pour portes forets E1



Verwendung:
Für VDI-Bohrerhalter E1
Application:
For VDI boring holders E1
Application:
Pour portes forets VDI E1

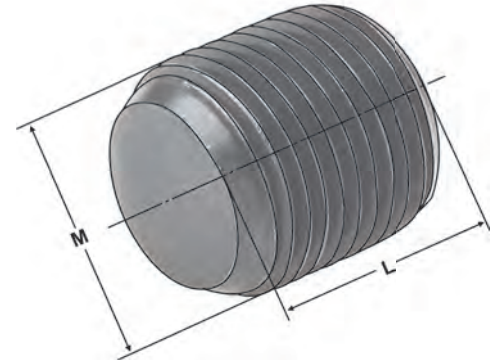

Bestell-Nr. Order no. Référence	M	L	für Artikelnummer for article number pour référence
102.91.10	M10x1	10	309.51.16 309.51.20 409.51.16 409.51.20 509.51.16 509.51.20
102.91.12	M12x1	12	309.51.25 309.51.32 409.51.25 409.51.32 509.51.25 509.51.32
102.91.16	M16x1	12	309.51.40 409.51.40 509.51.40 509.51.50

Spannschrauben für E1 Bohrerhalter mit Spitze

Clamping screws for E1 boring holders with point
Vis de serrage pour portes forets E1 avec pointe



Verwendung:
Für VDI-Bohrerhalter E1
Application:
For VDI boring holders E1
Application:
Pour portes forets VDI E1

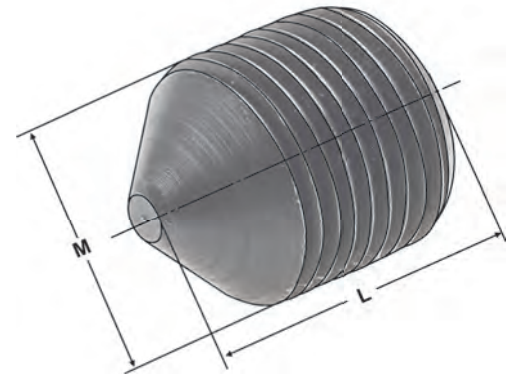

Bestell-Nr. Order no. Référence	M	L	für Artikelnummer for article number pour référence
102.93.10	M10x1	14	309.51.16 309.51.20 409.51.16 409.51.20 509.51.16 509.51.20
102.93.12	M12x1	14	309.51.25 309.51.32 409.51.25 409.51.32 509.51.25 509.51.32
102.93.16	M16x1	14	309.51.40 409.51.40 509.51.40 509.51.50

10

Clamping screws for E2 boring bar holders

Vis de serrage pour porte-outils pour barres d'alésage forme E2



Verwendung:
Für VDI-Bohrerhalter E2
Application:
For VDI boring holders E2
Application:
Pour portes forets VDI E2

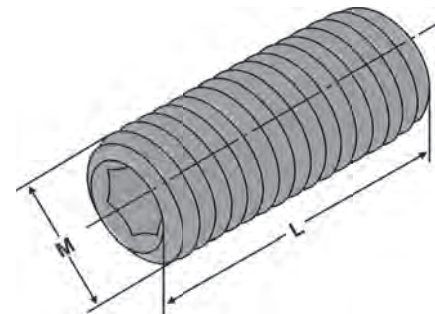

Bestell-Nr. Order no. Référence	M	L	für Artikelnummer for article number pour référence
102.91.06	M6	20	309.52.08 309.52.10
101.91.08.1	M8	16	309.52.16 309.52.20 309.52.25 309.52.32
101.91.08.2	M8	20	309.52.12 409.52.08 409.52.10 409.52.12
101.91.10	M10	12	409.52.40
101.91.10.1	M10	16	409.52.16 409.52.20 409.52.25 409.52.32
101.91.10.2	M10	20	509.52.12 509.52.16
101.91.12	M12	10	509.52.50
101.91.12.1	M12	16	509.52.32 509.52.40
101.91.12.2	M12	20	509.52.20 509.52.25



Hohlschlüssel mit Nasen / Nutmutternschlüssel

zur Demontage von Zwischenhülsen für MK mit Anzugsgewinde DIN 6364

Pipe key / groove-nut key for disassembling Morse taper adaptor for MT with drawbar thread DIN 6364
Clé pour écrou cylindrique à encoches pour le démontage de douilles cône morse
pour Douille de réduction pour CM avec filetage DIN 6364



Verwendung:
zur Demontage von Zwischenhülsen
Application:
for disassembling adaptor sleeves
Application:
pour le démontage de douilles cône morse

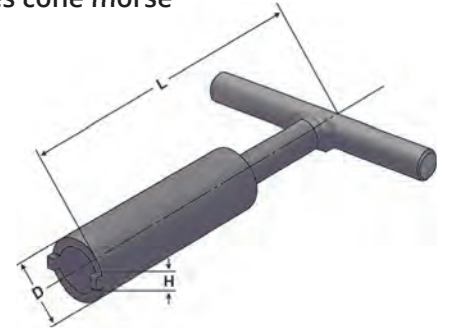

Bestell-Nr. Order no. Référence	D	L	H	für Artikelnummer for article number pour référence
02.08.01	12,5	105	3	401.08.01 402.08.01 405.08.01
02.08.011	9,5	110	2	A63.08.01 A100.08.01
02.08.02	12,5	120	2,5	401.08.02 402.08.02 405.08.02 A63.08.02 A100.08.02
02.08.03	18,5	135	3	401.08.03 402.08.03 405.08.03 501.08.01 501.08.02 501.08.03 501.08.04 501.08.04A 502.08.01 502.08.02 502.08.03 502.08.04 502.08.04A 505.08.01 505.08.02 505.08.03 505.08.04 505.08.04A A63.08.03 A100.08.03
02.08.04	22,5	175	3	401.08.04 401.08.04A 402.08.04 402.08.04A 405.08.04 405.08.04A A63.08.04 A100.08.04
02.08.05	26,5	205	3	501.08.05 501.08.05A 502.08.05 502.08.05A 505.08.05 505.08.05A A100.08.05

Spare part set for Morse taper adaptor for MT with drawbar thread DIN 6364

Jeu de pièces détachées pour Douille de réduction pour CM avec filetage DIN 6364



Lieferumfang:

Schraube, Gewinding und Klemmschraube

Delivery:

Bolt, Holding ring, Screw on holding ring

Livraison:

Vis, bague fileté, vis de serrage

Bestell-Nr. Order no. Référence	Schraube Bolt vis	Gewinding Holding ring bague fileté	Klemmschraube clamping screw vis de serrage	für for pour
ERS.401.08.01	M6x40	M16 x 6,5 x 10	M5x6	SK 40-1-50 DIN 2080
ERS.401.08.02	M10x45	M16 x 6,5 x 10	M5x6	SK 40-2-50 DIN 2080
ERS.401.08.03	M12x35	M20 x 13 x 10	M5x6	SK 40-3-65 DIN 2080
ERS.401.08.04	M16x45	M26 x 16,5 x 13	M5x6	SK 40-4-95 DIN 2080
ERS.402.08.01	M6x25	M16 x 6,5 x 10	M5x6	SK 40-1-50 DIN 69871 AD
ERS.402.08.02	M10x25	M16 x 11 x 6	M5x6	SK 40-2-50 DIN 69871 AD
ERS.402.08.03	M12x35	M20 x 13 x 10	M5x6	SK 40-3-70 DIN 69871 AD
ERS.402.08.04	M16x45	M26 x 16,5 x 13	M5x6	SK 40-4-95 DIN 69871 AD
ERS.405.08.01	M6x25	M16 x 6,5 x 10	M5x6	BT 40-1-50 MAS-BT
ERS.405.08.02	M10x25	M16 x 6,5 x 10	M5x6	BT 40-2-50 MAS-BT
ERS.405.08.03	M12x35	M20 x 13 x 10	M5x6	BT 40-3-70 MAS-BT
ERS.405.08.04	M16x45	M26 x 16,5 x 13	M5x6	BT 40-4-95 MAS-BT
ERS.501.08.01	M6x55	M24 x 6,5 x 12	M6x10	SK 50-1-60 DIN 2080
ERS.501.08.02	M10x70	M24 x 11 x 12	M6x10	SK 50-2-60 DIN 2080
ERS.501.08.03	M12x35	M24 x 13 x 12	M5x6	SK 50-3-65 DIN 2080
ERS.501.08.04	M16x35	M24 x 15 x 9,5	M6x10	SK 50-4-65 DIN 2080
ERS.501.08.05	M20x50	M36 x 21 x 14	M6x10	SK 50-5-120 DIN 2080
ERS.502.08.01	M6x40	M24 x 6,5 x 12	M6x10	SK 50-1-60 DIN 69871 A
ERS.502.08.02	M10x45	M24 x 11 x 12	M6x10	SK 50-2-60 DIN 69871 A
ERS.502.08.03	M12x35	M24 x 13 x 12	M5x6	SK 50-3-65 DIN 69871 A
ERS.502.08.04	M16x35	M24 x 15 x 9,5	M6x10	SK 50-4-70 DIN 69871 A
ERS.502.08.05	M20x50	M36 x 21 x 14	M6x10	SK 50-5-100 DIN 69871 A
ERS.505.08.01	M6x40	M24 x 6,5 x 12	M6x10	BT 50-1-45 MAS-BT
ERS.505.08.02	M10x45	M24 x 11 x 12	M6x10	BT 50-2-60 MAS-BT
ERS.505.08.03	M12x35	M24 x 13 x 12	M5x6	BT 50-3-65 MAS-BT
ERS.505.08.04	M16x35	M24 x 15 x 9,5	M6x10	BT 50-4-70 MAS-BT
ERS.505.08.05	M20x50	M36 x 21 x 14	M6x10	BT 50-5-100 MAS-BT
ERS.A100.08.01	M6x25	M10 x 6,2 x 8	M5x6	HSK 100-1-110
ERS.A100.08.02	M10x25	M16 x 11 x 6	M5x6	HSK 100-2-120
ERS.A100.08.03	M12x25	M20 x 13 x 10	M5x6	HSK 100-3-150
ERS.A100.08.04	M16x25	M26 x 16,5 x 13	M5x6	HSK 100-4-170
ERS.A100.08.05	M20x51	M36 x 21 x 14	M6x10	HSK 100-5-200
ERS.A63.08.01	M6x25	M10 x 6,2 x 8	M5x6	HSK 63-1-100
ERS.A63.08.02	M10x28	M16 x 11 x 6	M5x6	HSK 63-2-120
ERS.A63.08.03	M12x35	M20 x 13 x 10	M5x6	HSK 63-3-140
ERS.A63.08.04	M16x45	M26 x 16,5 x 13	M5x6	HSK 63-4-160



Hohlschlüssel mit Nasen / Nutmutternschlüssel

zur Demontage von Zwischenhülsen für SK-Aufnahmen

Pipe key / groove-nut key for disassembling adaptor sleeves for ISO-toolholders
Clé pour écrou cylindrique à encoches pour le démontage de douilles cône morse



Verwendung:
zur Demontage von Zwischenhülsen
Application:
for disassembling adaptor sleeves
Application:
pour le démontage de douilles cône morse

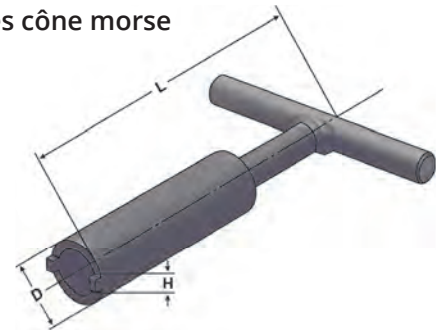

Bestell-Nr. Order no. Référence	D	L	H	für Artikelnummer for article number pour référence
02.09.30.1	18,5	111	4	401.09.30 402.09.30 405.09.30
02.09.40.1	24	141	2,8	401.09.40 402.09.40 405.09.40
02.09.40.2	20	111	2	501.09.40 502.09.40 505.09.40
02.09.50.2	35	166	3,5	501.09.50 502.09.50 505.09.50

Spare part set for Adaptor sleeves for ISO-toolholders

Jeu de pièces détachées pour Douilles de réduction pour porte-outils ISO/SA



Lieferumfang:

Schraube, Gewinding und Klemmschraube

Delivery:

Bolt, Holding ring, Screw on holding ring

Livraison:

Vis, bague fileté, vis de serrage

Bestell-Nr. Order no. Référence	Schraube Bolt vis	Gewinding Holding ring bague fileté	Klemmschraube clamping screw vis de serrage	für for pour
ERS.402.09.30	M12x50	M18 x 12,5 x 10	M5x6	SK40-SK30-50 DIN69871
ERS.402.09.40	M16x70	M26 x 16,5 x 13	M5x6	SK40-SK40-100 DIN69871
ERS.405.09.30	M12x50	M18 x 12,5 x 10	M5x6	SK40-SK30-50 MAS/BT
ERS.405.09.40	M16x70	M26 x 16,5 x 13	M5x6	SK40-SK40-100 DIN69871
ERS.502.09.40	M16x70	M24 x 15 x 9,5	M6x10	SK50-SK40-70 DIN69871
ERS.502.09.50	M24x80	M39 x 24,5 x 15	M6x10	SK50-SK50-120 DIN69871
ERS.505.09.40	M16x70	M24 x 15 x 9,5	M6x10	SK50-SK40-70 MAS/BT
ERS.505.09.50	M24x80	M39 x 24,5 x 15	M6x10	SK50-SK50-120 MAS/BT



Montageblock universal mit Kugellager

Universal ball bearing tightening fixture
Bloc de montage universel avec palier à billes



Verwendung:
Montagevorrichtung zur vertikalen und horizontalen Aufnahme von Werkzeugen mit Steilkegelschaft.

Application:
Assembly device for vertical and horizontal mounting of tools with steep taper shank.

Application:
Dispositif de montage pour le montage vertical et horizontal de porte-outils conique.

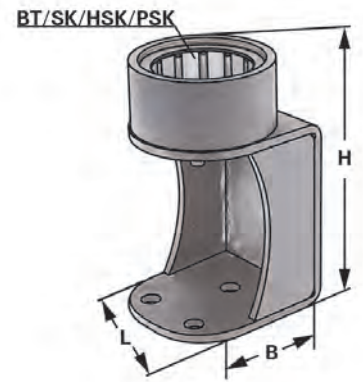

Bestell-Nr. Order no. Référence	Abmessung Size Dimension	L	B	H
706.63	HSK 63 - SK 40 - BT 40 - CAT 40 - C6	200	150	250

Hinweis: Max. Anzugsmoment 150 Nm
Note: Max. tightening torque 150 Nm
Observation: Couple de serrage maxi. 150 Nm

Universal assembly blocks made of steel, pivoted
 Blocs de montage universels en acier, pivotant



Verwendung:
 Schwenkbare Montagevorrichtung für
 Werkzeugaufnahmen. 360° drehbarer
 Kopf, arretierbar in verschiedenen Posi-
 tionen.

Application:
Hinged mounting device for toolholders.
*Head turnable for 360°, lockable in diffe-
 rent positions.*

Application:
 Appareil d'assemblage pivotant pour
 porte-outils. Tête tournant à 360°,
 arrêtable en different positions.

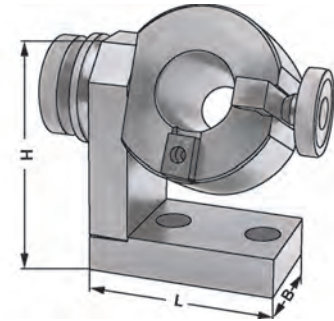

Bestell-Nr. Order no. Référence	Abmessung Size Dimension	L	B	H
705.30	SK/ISO/BT/CAT 30	111	65	134
705.40	SK/ISO/BT/CAT 40	111	65	132
705.50	SK/ISO/BT/CAT 50	111	65	175
708.32	HSK 32	111	65	132
708.40	HSK 40	111	65	132
708.50	HSK 50	111	65	132
708.63	HSK 63	111	65	132
708.80	HSK 80	111	65	132
708.10	HSK 100	111	65	132
709.16	VDI 16	100	48	97
709.20	VDI 20	100	48	97
709.30	VDI 30	111	65	132
709.40	VDI 40	111	65	132
709.50	VDI 50	111	65	132

K Montageblöcke aus Aluminium

Tightening fixtures made of aluminium
 Blocs de montage en aluminium



Verwendung:
 Montagevorrichtung zur vertikalen und horizontalen Aufnahme von Werkzeugen mit Steilkegelschaft.

Application:
 Assembly device for vertical and horizontal mounting of tools with steep taper shank.

Application:
 Dispositif de montage pour le montage vertical et horizontal de porte-outils conique.

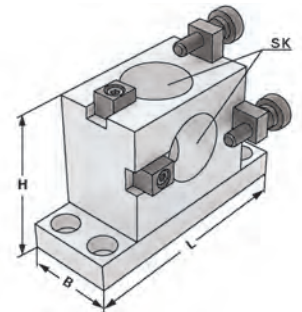

Bestell-Nr. Order no. Référence	Abmessung Size Dimension	L	B	H
700.30	SK/ISO/BT/CAT 30	126	47	75
700.40	SK/ISO/BT/CAT 40	160	60	100
700.50	SK/ISO/BT/CAT 50	180	97	155

Taper wipers
Nettoies cônes



Verwendung:
Zum Reinigen der Innenkegel an Maschinen-
spindeln, Hülsen und Werkzeugaufnahmen.
Application:
*For cleaning internal tapers on machine spindles,
sleeves and tool arbors.*
Application:
Destiné au nettoyage du cône de broches,
de douilles et de porte-outils.



Bestell-Nr. Order no. Référence	Abmessung Size Dimension
710.01.415	OZ 16
710.01.462	OZ 25
710.01.467	OZ 32
710.02.426	ER 16
710.02.430	ER 25
710.02.470	ER 32
710.02.472	ER 40
710.01	MK 1
710.02	MK 2
710.03	MK 3
710.04	MK 4
710.05	MK 5
710.30	SK/ISO/BT/CAT 30
710.40	SK/ISO/BT/CAT 40
710.50	SK/ISO/BT/CAT 50
710.32.HSK	HSK 32 Form A-C-E
710.40.HSK	HSK 40 Form A-C-E
710.50.HSK	HSK 50 Form A-C-E
710.63.HSK	HSK 63 Form A-C-E
710.80.HSK	HSK 80 Form A-C-E
710.100.HSK	HSK 100 Form A-C-E
710.63.HSK.F	HSK 63 Form F

Ausführung: Mit Rauhlederbesatz
Version: *With parts of leather*
Version: Parties en cuir

K Hydro-Dehnspannfutter mit Zylinderschaft

Hydraulic expansion chucks for tool shanks
Mandrins expansibles hydrauliques pour queues cylindriques



Verwendung:
Zur Aufnahme von Werkzeugen mit Zylinderschaft nach DIN 1835 Form A+B+E und DIN 6535 Form HA+HB+HE

Application:
For mounting straight-shank tools acc. DIN 1835 form A+B+E and DIN 6535 form HA+HB+HE

Application:
Pour le serrage d'outils avec queue cylindrique suivant DIN 1835 forme A+B+E et DIN 6535 forme HA+HB+HE

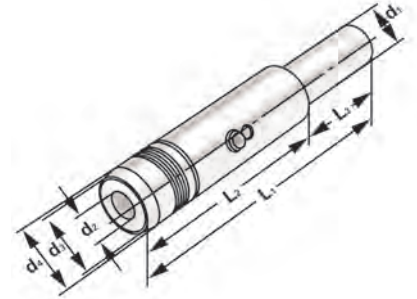

Bestell-Nr. Order no. Référence	d ₁	d ₂	d ₃	d ₄	l ₁	l ₂	l ₃
120.H12.12	12	12	21	25	146	100	46
120.H20.12	20	12	21	25	150	100	50
120.H20.16	20	16	25	28	150	100	50
120.H20.20	20	20	30	32	150	100	50
120.H32.12	32	12	21	25	200	140	60
120.H32.16	32	16	25	28	200	140	60
120.H32.20	32	20	30	32	200	140	60

Lieferumfang: Mit Spannschlüssel
Delivery: With wrench
Livraison: Avec clé de serrage

Shrink fit extensions (with end stop)
 Rallonges de frettage (avec butée)



Verwendung:
 Zur Aufnahme von Werkzeugen mit Zylinderschaft.
Application:
 For mounting straight-shank tools.
Application:
 Pour le serrage d'outils avec queue cylindrique.

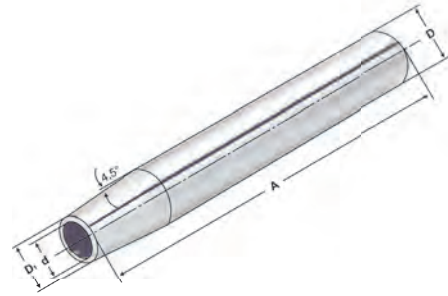

AD $\nabla \leq 0,003$

Bestell-Nr. Order no. Référence	D	d	D ₁	A	l ₁	l ₂
120.70.03	20	3	10	150	15	5
120.70.04	20	4	10	150	20	5
120.70.05	20	5	10	150	20	5
120.70.06*	20	6	10	150	36	10
120.70.08*	20	8	12	150	36	10
120.70.10*	20	10	14	150	42	10
120.70.12*	20	12	16	150	47	10

* mit Anschlag | * with end stop | * avec butée

Für Ø 3, 4 und 5 mm nur Hartmetallschäfte verwenden!
 For Ø 3, 4 and 5 mm only solid carbide tool shanks must be used!
 Pour Ø 3, 4 et 5 mm il faut seulement utiliser de queues d'outils carbures de type HM!

Hinweis: Aufnahmen für Induktiv-, Kontakt- und Heißluftschumpfergeräte geeignet.
 Schafttoleranz bei Ø 3, 4 und 5 mm = h₄, bei Ø 6 - Ø 32 mm = h₆

Note: Toolholders suitable for induction-, contact- and hot air shrink units.
 Ø 3, 4, 5 with h₄-tolerance and Ø 6 - Ø 32 with h₆-tolerance

Observation: Porte-outils convenables pour machines à fretter par induction-,
 par contact-, ou par air chaud.
 Ø 3, 4, 5 avec h₄-tolerance et Ø 6 - Ø 32 avec h₆-tolerance

l₁ = max. Einstecktiefe
 l₁ = max. clamping depth
 l₁ = max. profondeur d'insertion

l₂ = max. Verstellweg
 l₂ = max. length adjustment range
 l₂ = max. course de réglage



Reduziereinsätze DIN 1835 B für Zylinderschäfte DIN 1835 B+E

Reducing bushes DIN 1835 B for tool shanks DIN 1835 B+E
Réductions DIN 1835 B pour queues cylindriques DIN 1835 B+E



Verwendung:
Zum Spannen von zylindrischen Werkzeugschäften nach DIN 1835 Form B+E.

Application:
For mounting straight-shank tools according to DIN 1835 form B+E.

Application:
Pour le serrage d'outils avec queue cylindrique suivant DIN 1835 forme B+E.

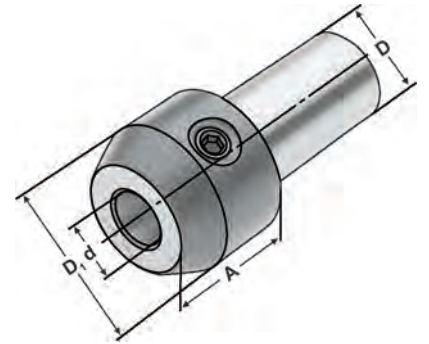

$\nabla \leq 0,010$

Bestell-Nr. Order no. Référence	D_{h6}	d_{H4}	D_1	A
122.20.06	20	6	25	30
122.20.08	20	8	28	30
122.20.10	20	10	35	30
122.20.12	20	12	42	35
122.32.06	32	6	25	30
122.32.08	32	8	28	30
122.32.10	32	10	35	30
122.32.12	32	12	42	35
122.32.14	32	14	44	35
122.32.16	32	16	48	38
122.32.18	32	18	50	38
122.32.20	32	20	52	40

Lieferumfang: Mit Spannschraube
Delivery: With clamping screw
Livraison: Avec vis de serrage

Collet chucks with straight shank with Mini nuts ISO 15488 (DIN 6499) System ER

Mandrins à pinces à queue cylindrique avec mini-écrous ISO 15488 (DIN 6499) système ER



Verwendung:
Zur Aufnahme von Werkzeugen mit Zylinderschaft in Spannzangen.

Application:
For mounting straight-shank tools in collets.

Application:
Pour le serrage d'outils avec queue cylindrique dans des pinces de serrage.

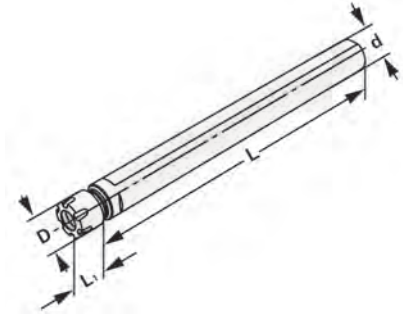

Bestell-Nr. Order no. Référence	d _{H6}	Spannbereich Capacity Capacité	L	L ₁	D
120.02.07	16	1 - 07 (ER 11)	150	20	16
120.02.10.1	20	1 - 10 (ER 16)	150	30	22

Lieferumfang: Inkl. Spannmutter
Delivery: Clamping nuts
Livraison: Ecrou de serrage





Spannfutter mit Zylinderschaft für Spannzangen

ISO 15488 (DIN 6499) System ER

Collet chucks with straight shank for collets ISO 15488 (DIN 6499) ER-system
Mandrins à pinces à queue cylindrique pour pinces ISO 15488 (DIN 6499) système ER



Verwendung:
Zur Aufnahme von Werkzeugen mit Zylinderschaft in Spannzangen.
Application:
For mounting straight-shank tools in collets.
Application:
Pour le serrage d'outils avec queue cylindrique dans des pinces de serrage.

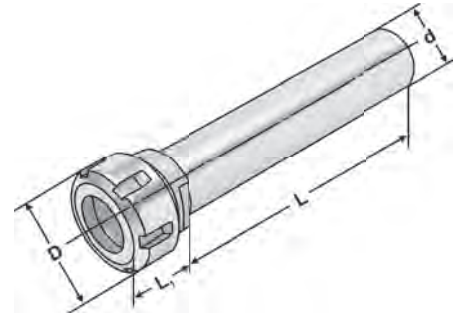

Bestell-Nr. Order no. Référence	d _{H6}	Spannbereich Capacity Capacité	L	L ₁	D
120.02.10	16	1 - 10 (ER 16)	150	30	32
120.02.16	20	1 - 16 (ER 25)	150	40	42
120.02.20	32	2 - 20 (ER 32)	150	35	50

Lieferumfang: Inkl. Spannmutter
Delivery: Clamping nuts
Livraison: Ecrou de serrage



ISO 15488 (DIN 6499) System ER

Collet chucks with straight shank with with clamping surface for collets ISO 15488 (DIN 6499) ER-system
 Mandrins à pinces à queue cylindrique avec surface de serrage pour pinces ISO 15488 (DIN 6499) système ER



Verwendung:
 Zur Aufnahme von Werkzeugen mit Zylinderschaft in Spannzangen.

Application:
 For mounting straight-shank tools in collets.

Application:
 Pour le serrage d'outils avec queue cylindrique dans des pinces de serrage.

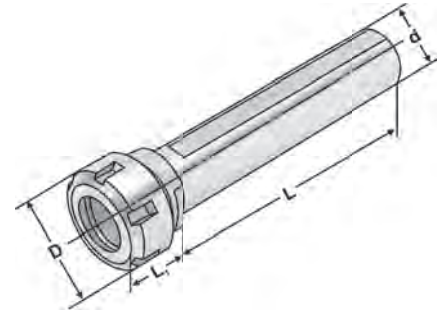

Bestell-Nr. Order no. Référence	d _{H6}	Spannbereich Capacity Capacité	L	L ₁	D
120.02.04.10	16	1 - 10 (ER 16)	150	30	32
120.02.04.16	20	1 - 16 (ER 25)	150	40	42
120.02.04.20	32	2 - 20 (ER 32)	150	35	50
120.02.04.20.1	40	2 - 20 (ER 32)	120	35	50

Lieferumfang: Inkl. Spannmutter
Delivery: Clamping nuts
Livraison: Ecrou de serrage





Spannfutter mit Zylinderschaft für Spannzangen

ISO 15488 (DIN 6499) System ER

Collet chucks with straight shank for collets ISO 15488 (DIN 6499) ER-system

Mandrins à pinces à queue cylindrique pour pinces ISO 15488 (DIN 6499) système ER



Verwendung:

Zur Aufnahme von Werkzeugen mit Zylinderschaft in Spannzangen.

Application:

For mounting straight-shank tools in collets.

Application:

Pour le serrage d'outils avec queue cylindrique dans des pinces de serrage.

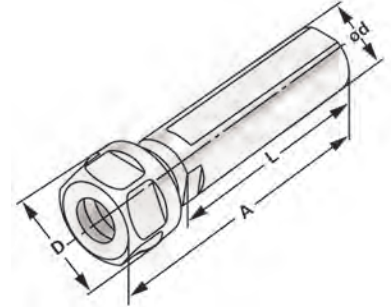

Bestell-Nr. Order no. Référence	Spannbereich Capacity Capacité	d _{H6}	D	L	A
120.02.A.07	1 – 07 (ER 11)	20	19	50	67,5
120.02.A.07.1	1 – 07 (ER 11)	20	19	70	87,5
120.02.A.10	1 – 10 (ER 16)	20	28	70	96,0
120.02.A.13	1 – 13 (ER 20)	25	34	50	74,0

Sechskantmutter
Hexagonal clamping nut
Écrous hexagonal

Doppel-Spannzangenhalter mit Zylinderschaft für Spannzangen ISO 15488 (DIN 6499) System ER

Double collet holder with straight shank for collets ISO 15488 (DIN 6499) ER-system

Porte-pinces doubles à queue cylindrique pour pinces ISO 15488 (DIN 6499) système ER

10



Verwendung:

Zur Aufnahme von Werkzeugen mit Zylinderschaft in Spannzangen.

Application:

For mounting straight-shank tools in collets.

Application:

Pour le serrage d'outils avec queue cylindrique dans des pinces de serrage.

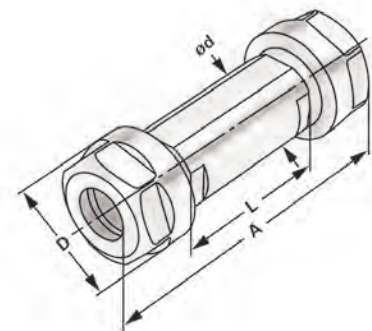

Bestell-Nr. Order no. Référence	Spannbereich Capacity Capacité	d _{H6}	D	L	A
120.02.B.13	1 – 13 (ER 20)	25	34	50	98,0

Sechskantmutter
Hexagonal clamping nut
Écrous hexagonal

Spannfutter mit Zylinderschaft mit Minimutter ISO 15488 (DIN 6499) System ER



Collet chucks with straight shank with Mini nuts ISO 15488 (DIN 6499) System ER

Mandrins à pinces à queue cylindrique avec mini-écrous ISO 15488 (DIN 6499) système ER



Verwendung:
Zur Aufnahme von Werkzeugen mit Zylinderschaft in Spannzangen.

Application:
For mounting straight-shank tools in collets.

Application:
Pour le serrage d'outils avec queue cylindrique dans des pinces de serrage.

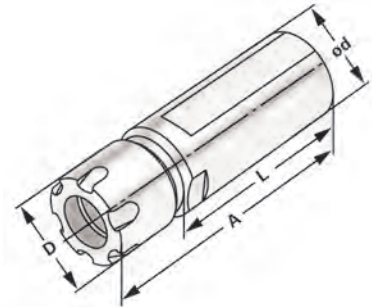

Bestell-Nr. Order no. Référence	Spannbereich Capacity Capacité	d _{H6}	D	L	A
120.02.C.10	1 – 10 (ER 16)	22	22	50	76,5

Mit Minimutter
With mini nut
Avec écrous-mini

Doppel-Spannzangenhalter mit Zylinderschaft mit Minimutter DIN 6499 (ISO 15488) System ER

Double collet holder with straight shank with Mini nuts ISO 15488 (DIN 6499) System ER

Porte-pinces doubles à queue cylindrique avec mini-écrous ISO 15488 (DIN 6499) système ER



Verwendung:
Zur Aufnahme von Werkzeugen mit Zylinderschaft in Spannzangen.

Application:
For mounting straight-shank tools in collets.

Application:
Pour le serrage d'outils avec queue cylindrique dans des pinces de serrage.

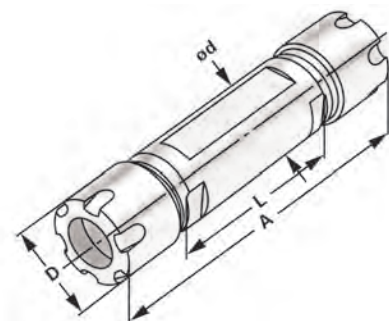

Bestell-Nr. Order no. Référence	Spannbereich Capacity Capacité	d _{H6}	D	L	A
120.02.D.10	1 – 10 (ER 16)	20	22	70	123

Mit Minimutter
With mini nut
Avec écrous-mini



Präzisions-Schnellspan-Bohrfutter für Bohrfutteraufnahmen DIN 238

Precision rapid clamping drill chucks for drill chuck adaptors DIN 238
Mandrins de perçage précis à serrage rapide pour arbres DIN 238



Verwendung:
Zur Aufnahme von Werkzeugen mit Zylinderschaft.

Application:
For mounting tools with straight shanks.

Application:
Pour le serrage d'outils avec queue cylindrique.

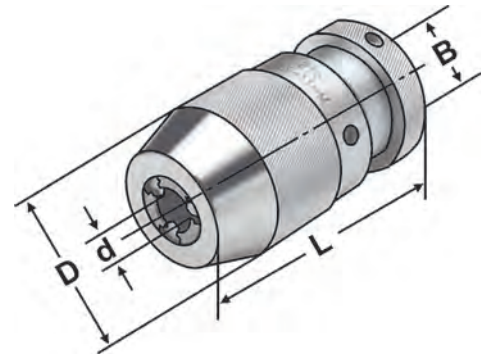

$\nabla \leq 0,030$



Bestell-Nr. Order no. Référence	B	Spannbereich Capacity Capacité	D	L
14.08.B12	B12	0,3 - 8	38	68
14.13.B16	B16	0,5 - 13	50	90
14.16.B16	B16	3,0 - 16	57	70

Hinweis: Schlüssellos, selbstspannend
Note: Keyless, self-clamping
Observation: Sans clé, serrage automatique



CNC-Drill chucks for drill chuck adaptors DIN 238
Mandrins de perçage CNC pour arbres DIN 238



Verwendung:
Zur Aufnahme von Werkzeugen mit Zylinderschaft.

Application:
For mounting tools with straight shanks.

Application:
Pour le serrage d'outils avec queue cylindrique.

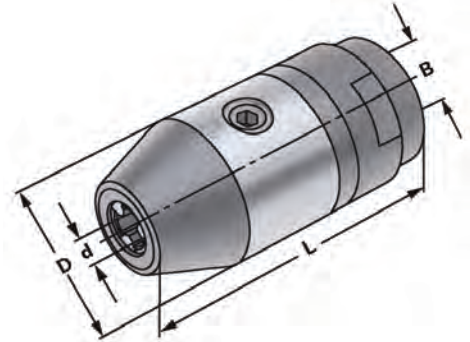

$\nabla \leq 0,030$



Bestell-Nr. Order no. Référence	B	d	Spannbereich Capacity Capacité	D	L
15.08.B12	B12	0 - 8		36	76
15.13.B16	B16	1,0 - 13		50	102
15.16.B16	B16	2,5 - 16		50	102

- Hinweis:** Hohe Präzision und Rundlaufgenauigkeit von $\leq 0,03$ mm. Sichere Spannung des Werkzeuges durch mechanische Spannkraftverstärkung. Kein selbständiges Lösen der Spannung während der Bearbeitung bei Links- oder Rechtslauf, sowie bei Spindelstop. Spannen und Lösen mit Sechskantschlüssel.
- Note:** *High precision and accurate concentricity of ≤ 0.03 mm. Secure gripping of the tool through mechanical amplification of the clamping force. No automatic slackening of the clamping force while machining with either clockwise or counter clockwise rotation or on spindle stop. Clamping and releasing effected by means of an Allen wrench.*
- Observation:** Précision élevée et exactitude de circularité de $\leq 0,03$ mm. Serrage sûr de l'outil grâce à l'amplification de la force de serrage. Pas de desserrage intempestif en cours d'usinage lors de la rotation la gauche ou la droite, de même qu'en cas d'arrêt de la broche. Serrage et desserrage en utilisant un clé sur à fourche.
- Lieferumfang:** Mit Spannschlüssel
Delivery: With wrench
Livraison: Avec clé de serrage





CNC-Bohrfutter mit Zylinderschaft DIN 1835 B

CNC-Drill chucks with straight shank DIN 1835 B
Mandrins de perçage CNC à queue cylindrique DIN 1835 B



Verwendung:
Zur Aufnahme von Werkzeugen mit Zylinderschaft.

Application:
For mounting tools with straight shanks.

Application:
Pour le serrage d'outils avec queue cylindrique.

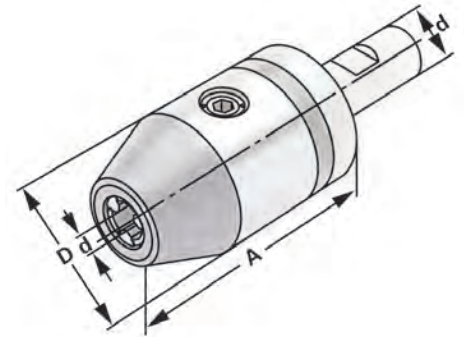

$\nabla \leq 0,030$

14.04

Bestell-Nr. Order no. Référence	d	d1	Spannbereich Capacity Capacité	A	D
120.15.2013	20	1,0 - 13		143	50
120.15.2016	20	2,5 - 16		148	50

Hinweis: Hohe Präzision und Rundlaufgenauigkeit von $\leq 0,03$ mm. Sichere Spannung des Werkzeuges durch mechanische Spannkraftverstärkung. Kein selbständiges Lösen der Spannung während der Bearbeitung bei Links- oder Rechtslauf, sowie bei Spindelstop. Spannen und Lösen mit Sechskantschlüssel.

Note: *High precision and accurate concentricity of ≤ 0.03 mm. Secure gripping of the tool through mechanical amplification of the clamping force. No automatic slackening of the clamping force while machining with either clockwise or counter clockwise rotation or on spindle stop. Clamping and releasing effected by means of an Allen wrench.*

Observation: Précision élevée et exactitude de circularité de $\leq 0,03$ mm. Serrage sûr de l'outil grâce à l'amplification de la force de serrage. Pas de desserrage intempestif en cours d'usinage lors de la rotation la gauche ou la droite, de même qu'en cas d'arrêt de la broche. Serrage et desserrage en utilisant un clé sur à fourche.

Lieferumfang: Mit Spannschlüssel
Delivery: With wrench
Livraison: Avec clé de serrage

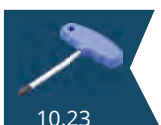

CNC-Drill chucks for MT
Mandrins de perçage CNC pour CM



Verwendung:
Zur Aufnahme von Werkzeugen mit Zylinderschaft.

Application:
For mounting tools with straight shanks.

Application:
Pour le serrage d'outils avec queue cylindrique.

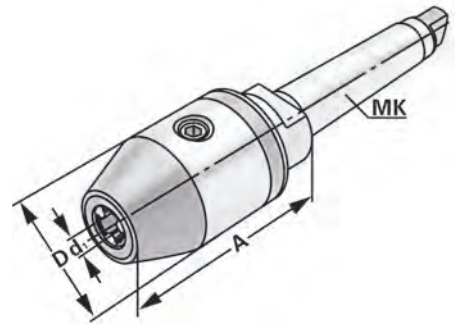

$\nabla \leq 0,030$

14.04

Bestell-Nr. Order no. Référence	MK MT CM	Spannbereich Capacity Capacité	A	D
107.15.313	3	1,0 – 13	98	50
107.15.316	3	2,5 – 16	103	50
107.15.413	4	1,0 – 13	100	50
107.15.416	4	2,5 – 16	105	50

Hinweis: Hohe Präzision und Rundlaufgenauigkeit von $\leq 0,03$ mm. Sichere Spannung des Werkzeuges durch mechanische Spannkraftverstärkung. Kein selbständiges Lösen der Spannung während der Bearbeitung bei Links- oder Rechtslauf, sowie bei Spindelstop. Spannen und Lösen mit Sechskantschlüssel.

Note: *High precision and accurate concentricity of ≤ 0.03 mm. Secure gripping of the tool through mechanical amplification of the clamping force. No automatic slackening of the clamping force while machining with either clockwise or counter clockwise rotation or on spindle stop. Clamping and releasing effected by means of an Allen wrench.*

Observation: Précision élevée et exactitude de circularité de $\leq 0,03$ mm. Serrage sûr de l'outil grâce à l'amplification de la force de serrage. Pas de desserrage intempestif en cours d'usinage lors de la rotation la gauche ou la droite, de même qu'en cas d'arrêt de la broche. Serrage et desserrage en utilisant un clé sur à fourche.

Lieferumfang: Mit Spannschlüssel
Delivery: With wrench
Livraison: Avec clé de serrage





Hydro-Dehnspannfutter Ø 20 - DIN 69871 AD/B im Holzkasten und Reduzierungen

Hydraulic expansion chucks Ø 20 - DIN 69871 AD/B
Mandrins expansibles hydrauliques Ø 20 - DIN 69871 AD/B

Bestell Nr. <i>Order no. / Réf.</i>	Abmessung <i>Size / Dimension</i>	Reduzierung <i>Reduction sleeves / Douilles de réduction</i>	Typ <i>type / Type</i>
403.H20.R.S	SK 40 - 20 - 82	6 - 8 - 10 - 12 - 16	Nicht abgedichtet <i>not sealed</i> non étanche
403.H20.RD.S	SK 40 - 20 - 82	6 - 8 - 10 - 12 - 16	Abgedichtet <i>sealed</i> étanche
503.H20.R.S	SK 50 - 20 - 82	6 - 8 - 10 - 12 - 16	Nicht abgedichtet <i>not sealed</i> non étanche
503.H20.RD.S	SK 50 - 20 - 82	6 - 8 - 10 - 12 - 16	Abgedichtet <i>sealed</i> étanche



Hydro-Dehnspannfutter Ø 20 - JIS B 6339 (MAS-BT) AD/B im Holzkasten und Reduzierungen

Hydraulic expansion chucks Ø 20 - JIS B 6339 (MAS-BT) AD/B
Mandrins expansibles hydrauliques Ø 20 - JIS B 6339 (MAS-BT) AD/B

Bestell Nr. <i>Order no. / Réf.</i>	Abmessung <i>Size / Dimension</i>	Reduzierung <i>Reduction sleeves / Douilles de réduction</i>	Typ <i>type / Type</i>
406.H20.R.S	BT 40 - 20 - 90	6 - 8 - 10 - 12 - 16	Nicht abgedichtet <i>not sealed</i> non étanche
406.H20.RD.S	BT 40 - 20 - 90	6 - 8 - 10 - 12 - 16	Abgedichtet <i>sealed</i> étanche
506.H20.R.S	BT 50 - 20 - 110	6 - 8 - 10 - 12 - 16	Nicht abgedichtet <i>not sealed</i> non étanche
506.H20.RD.S	BT 50 - 20 - 110	6 - 8 - 10 - 12 - 16	Abgedichtet <i>sealed</i> étanche



Hydro-Dehnspannfutter Ø 20 - DIN 69893 Form A im Holzkasten und Reduzierungen

Hydraulic expansion chucks Ø 20 - DIN 69893 Form A
Mandrins expansibles hydrauliques Ø 20 - DIN 69893 Form A

Bestell Nr. <i>Order no. / Réf.</i>	Abmessung <i>Size / Dimension</i>	Reduzierung <i>Reduction sleeves / Douilles de réduction</i>	Typ <i>type / Type</i>
A63.H20.R.S	HSK 63 - 20 - 100	6 - 8 - 10 - 12 - 16	Nicht abgedichtet <i>not sealed</i> non étanche
A63.H20.RD.S	HSK 63 - 20 - 100	6 - 8 - 10 - 12 - 16	Abgedichtet <i>sealed</i> étanche
A100.H20.R.S	HSK 100 - 20 - 105	6 - 8 - 10 - 12 - 16	Nicht abgedichtet <i>not sealed</i> non étanche
A100.H20.RD.S	HSK 100 - 20 - 105	6 - 8 - 10 - 12 - 16	Abgedichtet <i>sealed</i> étanche

abgeflachte Ausführung mit Hartmetall-Einsatz 60°

Solid half point with carbide insert - DIN 806 HE 60°

Demi-pointe fixe avec insert en métal dur - DIN 806 HE 60°



Verwendung:
Zum Plandrehen der Stirnflächen und für kleine Durchmesser.

Application:
For front surfacing and small diameters.

Application:
Pour surfacer les faces et pour les petits diamètres.

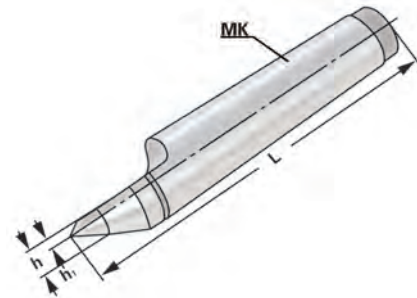

Bestell-Nr. Order no. Référence	MK	h ₁	h	L
109.11.01	1	1,5	5,5	80
109.11.02	2	2	6	100
109.11.03	3	3	9	125
109.11.04	4	5	12,5	160
109.11.05	5	7	16	200



Hartmetall Zentrierspitzen DIN 806 E -

Volle Ausführung mit Hartmetall-Einsatz 60°

Solid lathe centre with carbide insert - DIN 806 E 60°
Pointe fixe avec insert en métal dur - DIN 806 E 60°



Verwendung:
Zum Plandrehen der Stirnflächen und für kleine Durchmesser.

Application:
For front surfacing and small diameters.

Application:
Pour surfacer les faces et pour les petits diamètres.

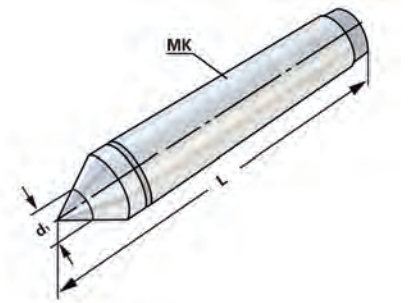

Bestell-Nr. Order no. Référence	MK	d ₁	L
109.12.01	1	8	80
109.12.02	2	8	100
109.12.03	3	12	125
109.12.04	4	15	160
109.12.05	5	18	200

Mitlaufende Drehbankspitze mit verlängerter Spitze 60°



Revolving lathe centre with extended point 60°
Pointe tournante allongée 60°



Verwendung:
Im Reitstock der Drehmaschinen, damit zwischen Werkstück und Spitze keine Reibung entsteht.

Application:
In the tailstock of the lathe so that no friction occurs between the workpiece and the tip.

Application:
Dans la contre-poupée de la Tourneuse afin qu'aucun frottement a lieu entre la pièce à usiner et la pointe.

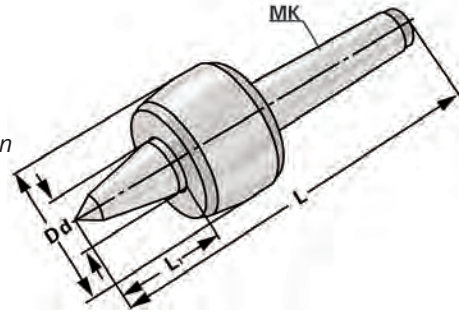

Bestell-Nr. Order no. Référence	MK	L	D	L ₁	d
109.13.02	2	139	45	34	20
109.13.03	3	176,5	60	47	25
109.14.04	4	217	70	53	32
109.13.05	5	273	90	65	40



Mitlaufende Drehbankspitze 60°

Revolving lathe centre 60°
Pointe tournante 60°



Verwendung:
Im Reitstock der Drehmaschinen,
damit zwischen Werkstück und
Spitze keine Reibung entsteht.

Application:
*In the tailstock of the lathe so that no
friction occurs between the workpi-
ece and the tip.*

Application:
Dans la contre-poupée de la Tour-
neuse afin qu'aucun frottement
a lieu entre la pièce à usiner et la
pointe.

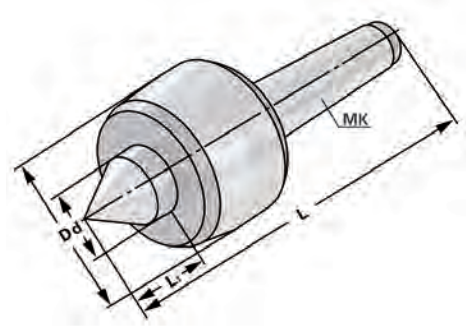

Bestell-Nr. Order no. Référence	MK	L	D	L ₁	d
109.14.01	1	114	36	17	15
109.14.02	2	129	45	24	20
109.14.03	3	151,5	50	27,5	22
109.14.04	4	205	70	41	32
109.14.05	5	258,5	90	51	40

Set of parallel supports
Jeu de supports parallèles



Verwendung:

Parallelunterlagen finden vielseitige Verwendung als Hilfsmittel zum Spannen und Positionieren, z.B. beim Schleifen, Fräsen, Erodieren, Messen und Anreissen.

Application:

Parallels are widely used as a tool for tensioning and positioning, e.g. during grinding, milling, EDM, gauging and scribing.

Application:

Parallèles sont largement utilisés comme un outil pour la tension et le positionnement, p. e., pendant l'affûtage, fraisage, EDM, mesurage et traçage.

Bestell-Nr. Order no. Référence	Ausführung Version Type
91.12.150.1	14 x 2 - 150 x 10 x 14 (16,18,20,22,24,26,28,30,32,35,40,45,50)
91.12.150.2	14 x 2 - 150 x 8 x 14 (16,18,20,22,24,26,28,30,32,35,40,45,50)
91.12.200.3	14 x 2 - 200 x 10 x 14 (16,18,20,22,24,26,28,30,32,35,40,45,50)
91.13.100.1	9 x 2 - 100 x 4 x 10 (14,18,22,26,30,34,38,42)

Härte: HRC 55 - 62
Hardness: HRC 55 - 62
Dureté: HRC 55 - 62

Genauigkeit: 0,01mm
Accuracy: 0,01mm
Exactitude: 0,01mm

Parallelität: 0,005mm
Parallelism: 0,005mm
Parallélisme: 0,005mm



CNC Tischaufsatzgestelle

Bench stand for CNC toolholders
Étagère pour porte-outils CNC

2 oder 4 Kassetten mit verschraubtem Korpus,
Ablage und Haltegriffen
(Inkl. Werkzeugaufnahmeträger, ohne Einsätze)

2 or 4 magazines with bolted corpus, rack and handles
(incl. Tool carrier, without inserts)

2 ou 4 cassettes avec corps vissé, support et poignées
(avec support, sans inserts)



Bestell-Nr. Order no. / Référence	Abmessung BxTxH Size / Dimension	E1 *	E2 *	E3 *
788.8705.200	425x375x300	14	10	6



Bestell-Nr. Order no. / Référence	Abmessung BxTxH Size / Dimension	E1 *	E2 *	E3 *
788.8707.200	575x375x300	20	14	10



Bestell-Nr. Order no. / Référence	Abmessung BxTxH Size / Dimension	E1 *	E2 *	E3 *
788.8705.400	425x375x525	28	20	12



Bestell-Nr. Order no. / Référence	Abmessung BxTxH Size / Dimension	E1 *	E2 *	E3 *
788.8707.400	575x375x525	40	28	20

10

*Anzahl der möglichen Einsätze, für die Größen E1, E2, E3

* Quantity of possible inserts, for sizes E1, E2, E3

* Nombre des inserts possibles, pour les tailles E1, E2, E3

Trolley for CNC toolholders
Chariot pour porte-outils CNC

CNC Werkzeugwagen (leer) für max. 8 CNC Träger
Maximale Tragkraft 400 kg
Ohne Werkzeugaufnahmeträger und ohne Einsätze

Trolley (empty) for max. 8 carriers
Maximum lifting force 400kg.
(Without Tool carrier and without inserts)
Chariot (vide) pour 8 supports
Maximum force portante max. 400 kg
(sans support et sans inserts)



Bestell-Nr. Order no. / Référence	Abmessung BxTxH Size / Dimension
799.02.88.0	630x900x860

CNC Werkzeugaufnahmeträger

Tool carrier for CNC toolholders
Support pour porte-outils CNC



Bestell-Nr. Order no. / Référence	Abmessung BxTxH Size / Dimension	E1 *	E2 *	E3 *
799.28.707.100	620x120x180	10	7	5

*Anzahl der möglichen Einsätze, für die Größen E1, E2, E3
* Quantity of possible inserts, for sizes E1, E2, E3
* Nombre des inserts possibles, pour les tailles E1, E2, E3

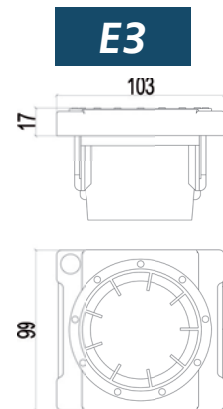
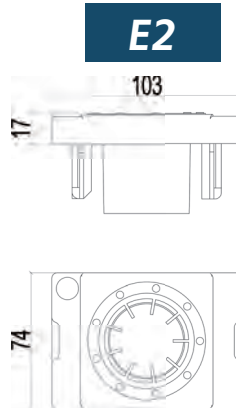
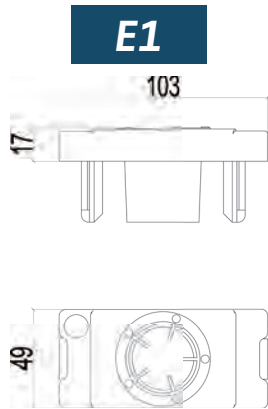

E1

Bestell-Nr. Order no. / Référence	Abmessung Size / Dimension
785.01.30	ISO / SK 30
785.02.30	VDI 30
785.03.30	MK 3
785.03.40	MK 4



E2

Bestell-Nr. Order no. / Référence	Abmessung Size / Dimension
785.01.40	SK 40
785.02.40	VDI 40
786.01.50	HSK A 50 / B63
786.01.63	HSK A 63 / B80
785.03.50	MK 5



E3

Bestell-Nr. Order no. / Référence	Abmessung Size / Dimension
785.01.50	ISO / SK 50
785.02.50	VDI 50
786.01.80	HSK A 80 / B100
786.01.100	HSK A 100 / B125



E3

Bestell-Nr. Order no. / Référence	Abmessung Size / Dimension
786.01.40	HSK A 40 / B 50



E3

Bestell-Nr. Order no. / Référence	Abmessung Size / Dimension
786.01.32	HSK A 32 / B 40

E3

Bestell-Nr. Order no. / Référence	Abmessung Size / Dimension
786.01.00	Universal



E3

Bestell-Nr. Order no. / Référence	Abmessung Size / Dimension
786.01.03	Capto C3



E1

Bestell-Nr. Order no. / Référence	Abmessung Size / Dimension
786.01.04	Capto C4



E2

Bestell-Nr. Order no. / Référence	Abmessung Size / Dimension
786.01.05	Capto C5



E3

Bestell-Nr. Order no. / Référence	Abmessung Size / Dimension
786.01.06	Capto C6



E3

Bestell-Nr. Order no. / Référence	Abmessung Size / Dimension
786.01.08	Capto C8





Induktions-Schrumpfgerät KSG 2020

Induction Shrink-fit unit KSG 2020

Appareil de frettage induction KSG 2020



Das KEMMLER Induktions-Schrumpfgerät „KSG 2020“ mit zusammenfaltbarem Kühlturm stellt den Aufstieg zum effizienten Schrumpfen mit integrierter Flüssigkeitskühlung dar. Schrumpfen und Kühlen findet in einer Position ohne Handling der Schrumpffutter statt.

Das Induktions-Schrumpfgerät „KSG 2020“ eignet sich zum Schrumpfen von HM-Schäften Ø 3 – 32 mm und Stahlschäften Ø 6 – 32 mm.

- Schrumpfparameter für alle Standardfutter im Prozessor gespeichert
- 50 Sonderparameter speicherbar
- Manuelles Schrumpfen möglich
- Schrumpffutterlänge bis 400 mm
- Spule wird von Hand geführt
- Einfache Menüführung im Grafikdisplay mit Dialogsteuerung
- Wasserkühlung zur schnellen Werkzeugkühlung
- Steuerung des Kühlvorgangs durch Aufziehen des Kühlturms
- Die Werkzeugkühlung erfolgt im zusammenfaltbaren Kühlturm

Die „KSG 2020“ Induktions-Schrumpfanlage verfügt über die Wechselspulentechnik. Hier kann die Spule gewechselt werden und dadurch bis Ø50mm geschrumpft werden.

The KEMMLER induction shrink unit „KSG 2020“ with foldable cooling tower is the progression to efficient shrinking with integrated liquid cooling. Shrinking and cooling are carried out in one position without the need to handle the shrink chucks.

The induction shrink unit „KSG 2020“ is suitable for the shrinking of HM shafts Ø 3 – 32 mm and of steel shafts Ø 6 – 32 mm.

- Shrink parameters for all standard chucks are stored in the processor
- 50 parameter sets for special tools can be stored
- Manual shrinking is possible
- Max. shrink-fit chuck length 400 mm
- Coil is guided manually
- Simple menu guidance in the graphic display with dialogue control
- Water cooling in the foldable cooling tower

The induction shrink machine „KSG 2020“ is equipped with the exchange coil technology. The coil can be changed and shrink diameter range goes up to 50mm.



L'appareil de frettage induction KEMMLER „KSG 2020“ avec tour de refroidissement repliable représente le passage à un rétrécissement efficace avec refroidissement par liquide intégré. La rétraction et le refroidissement ont lieu dans une position sans manipulation du mandrin rétractable.

L'appareil de frettage induction „KSG 2020“ convient pour la réduction des queues HM Ø 3 - 32 mm et des tiges en acier Ø 6 - 32 mm.

- Paramètres de réduction pour tous les mandrins standard stockés dans le processeur
- 50 paramètres spéciaux peuvent être sauvegardés
- Rétrécissement manuel possible
- Longueur du mandrin de serrage jusqu'à 400 mm
- La bobine est guidée à la main
- Navigation de menu simple dans l'affichage graphique avec contrôle de dialogue
- Refroidissement à l'eau pour un refroidissement rapide des outils
- Contrôle du processus de refroidissement en montant la tour de refroidissement
- Le refroidissement de l'outil a lieu dans la tour de refroidissement démontable

L'appareil de frettage induction „KSG 2020“ intègre la technologie de bobinage. Ici, la canette peut être changée et réduite à Ø50mm.

- Keine Verbrennungsgefahr, Schrumpffutter kommt immer komplett abgekühlt hoch
 - Keine Zerstörung der Schrumpffutter durch Überhitzen / Verglühen der Schrumpffutter, da Schrumpffutter IMMER auf Raumtemperatur abgekühlt wird
 - Erhaltung des Rundlaufs durch gleichmäßiges Abkühlen

- No risk of burning, shrink chuck always comes up fully cooled down
 - No damage to the shrink chucks by overheating/burning, as the shrink chuck is ALWAYS cooled down to room temperature
 - Concentricity is maintained by uniform cooling down process

- Aucun risque de brûlure, mandrin rétractable vient toujours complètement refroidi
 - Aucune destruction du mandrin de serrage due à une surchauffe / brûlure de la doublure de retrait, en tant que doublure de retrait TOUJOURS est refroidi à la température ambiante
 - Maintien de la concentricité par refroidissement uniforme

Bedienfeld <i>Control panel</i> Panneau de commande	grafisch (GUI) <i>graphical (GUI)</i> graphique (GUI)
Spannbereich HM <i>Clamping range SC</i> Plage de serrage HM	Ø 3 - 32 mm
Spannbereich HSS <i>Clamping range HSS</i> Plage de serrage HSS	Ø 6 - 32 mm
Spule <i>Coil</i> Bobine	fest, 4 Wechselscheiben <i>fixed, 4 pole discs</i> fice, 4 Disques de remplacement
Max. Werkzeuglänge <i>Max. Tool length</i> Max. longueur d'outil	500 mm bei HSK-A63 <i>500 mm at HSK-A63</i> 500 mm chez HSK-A63
Max. Kühllänge <i>Max. Cooling length</i> Max. longueur de refroidir	160 mm bei HSKA-63 <i>160 mm at HSKA-63</i> 160 mm chez HSKA-63
Kühlart <i>Cooling type</i> Type de refroidissement	Flüssigkeitskühlung - konturunabhängig <i>Liquid cooling - geometry independent</i> Refroidissement liquide - contour indépendant
Kühlzeit <i>Cooling time</i> Temps de refroidissement	30 sec.
Flüssigkeitstank <i>Liquid tank</i> Réservoir de liquide	28 l
Konturunabhängiges Kühlen <i>Geometry independent cooling</i> Refroidissement indépendant	Ja Yes Oui
Max. Maschinenschnittstelle <i>Max. machine interface</i> Max. interface de la machine	HSK-A 100 / SK50
Leistung <i>Power</i> Performance	11 kW
Stromversorgung <i>Electric current supply</i> Alimentation courant électrique	400 V / 16 A / 50 Hz
Maße (B x T x H) <i>Dimensions (W x D x H)</i> Dimensions (L x L x H)	800 x 560 x 1130 mm
Benötigtes Zubehör <i>Required accessories</i> Accessoires nécessaires	Werkzeugaufnahme <i>Tool holder</i> Porte-outil
Lieferumfang <i>Delivery package</i> Contenu de la livraison	Schrumpfgerät inkl. Spule (Ø 3 – 32 mm), 4 Wechselscheiben, Schutzhandschuhe, 1 Liter Kühlmittelkonzentrat, Bedienungsanleitung. Achtung: Lieferung ohne Aufnahmenadapter <i>Shrink machine with coil (Ø 3 – 32 mm), 4 pole discs, protective gloves, 1 litre coolant concentrate, operation manual</i> Attention: delivery without toolholder adapter <i>Dispositif de frettage avec bobine (Ø 3 – 32 mm), 4 Disques de remplacement, gants de protection, 1 litre liquide de refroidissement, instruction d'opération.</i> Attention: livraison sans adaptateur de porte-outils
Bestell-Nr. <i>Order no.</i> Référence	Ausführung <i>Version</i> Type
750.2020	KSG 2020



Werkzeugaufnahmen Adapter - wassergekühlt

Toolholder adapter - water cooled
Posage pour porte-outils



Verwendung:

Für die Aufnahme und korrekte Positionierung des Schrumpffutters auf dem Schrumpfgerät.

Application:

For the correct holding and positioning of the shrink chuck.

Application:

Pour la position correcte des mandrins de frettage dans l'appareil de frettage.

Bestell-Nr. Order no. Référence	Kegel Cone Cône
750.21.HSK32	HSK32
750.21.HSK40	HSK40
750.21.HSK50	HSK50
750.21.HSK63	HSK63
750.21.HSK80	HSK80
750.21.HSK100	HSK100
750.21.SK30	SK30 BT30 CAT30
750.21.SK40	SK40 BT40 CAT40
750.21.SK50	SK50 BT50 CAT50
750.21.C3	C3 (PSK - ISO 26623)
750.21.C4	C4 (PSK - ISO 26623)
750.21.C5	C5 (PSK - ISO 26623)
750.21.C6	C6 (PSK - ISO 26623)
750.21.C8	C8 (PSK - ISO 26623)

Length adjusting sleeve
 Douilles de pré réglage linéaires



Verwendung:
 Mit der Längeneinstellhülse kann genau bestimmt werden, wie weit das Schneidwerkzeug aus dem Schrumpffutter herausragt.

Application:
The length of the adjusting sleeve helps to determine exactly how far the cutting tool come out of the shrink fit chuck.

Application:
 La douille mesure le dépassement chez les outils coupants plus précisément.

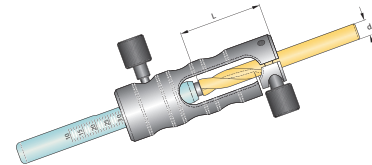

Bestell-Nr. Order no. Référence	d	L
750.24.01	3	5 - 25
750.24.02	3	30 - 50
750.24.03	4	5 - 25
750.24.04	4	30 - 50
750.24.05	5	5 - 25
750.24.06	5	30 - 50
750.24.07	6	10 - 35
750.24.08	6	35 - 60
750.24.09	8	10 - 35
750.24.10	8	35 - 60
750.24.11	10	15 - 50
750.24.12	10	35 - 60
750.24.13	12	15 - 50
750.24.14	16	30 - 65



Servicepumpe

Service pump
Pompe de service



Verwendung:

Die Servicepumpe kann zum Entleeren des Kühlmittel tanks des Schrumpfgerätes verwendet werden.

Application:

The service pump can be used to empty the cooling tank of the shrink-fit unit.

Application:

Pour pouvoir vider les cuves de refroidissement dans les appareils de frettage.

Bestell-Nr.
Order no.
Référence

705.26

Leistung 9 Liter / min. | Accièvement 9 litre / min. | Performance 9 litre / min.

Coolant emulsion
Émulsion de refroidissement



Verwendung:

Kühlemulsion zum Schutz der Schrumpffutter vor Korrosion.

Application:

Coolant emulsion for protecting shrink chucks of corrosion.

Application:

Le refroidissement pour la protection des mandrins de serrage en cas de corrosion

Bestell-Nr.
Order no.
Référence

750.27

MASCHINENSCHRAUBSTÖCKE

MACHINE VICES

ÉTAUX DE LA MACHINE

MASCHINENSCHRAUBSTÖCKE

MACHINE VICES

ÉTAUX DE LA MACHINE

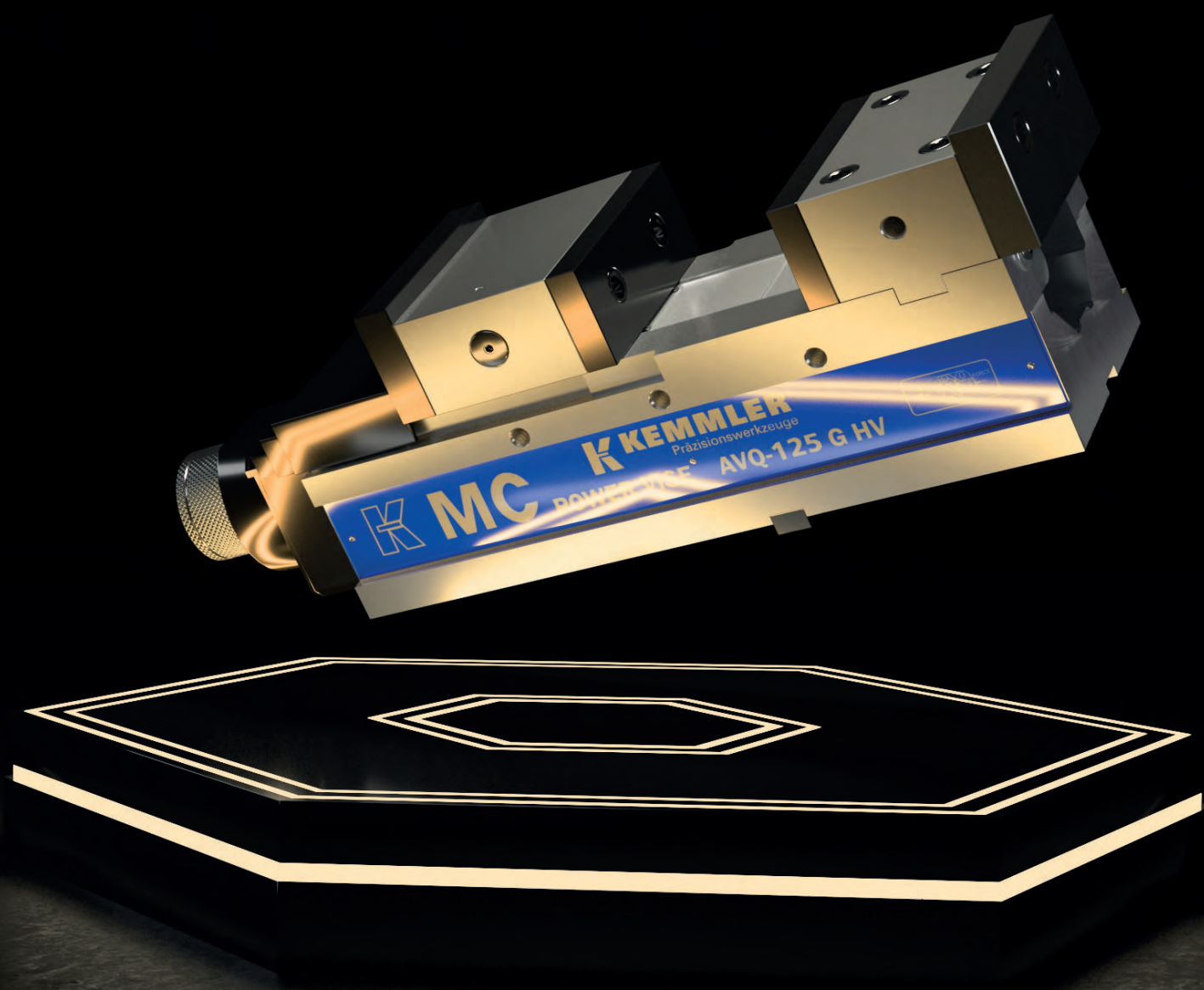



Präzisionsschraubstöcke

Precision vices
Étaux de précision

- ❶ Einzigartiges Spannbacken-System zur Erhöhung der Spannkraft
 - ❷ Das patentierte Anti-Lift-System garantiert eine problemlose Bearbeitung, ohne Anhub des Werkstückes
 - ❸ Spannkraft mit Hilfe von Rillenmarkierungen voreinstellbar
 - ❹ Durch den mechanischen Spannkraftverstärker kann auch während extremer Arbeiten am Werkstück eine konstant hohe Spannkraft von bis zu 6500 kg erzielt werden
 - ❺ Alle Verschleißteile sind gehärtet und geschliffen
-
- ❶ Unique clamping-jaw-system increases the clamping capacity
 - ❷ The new Anti-Lift mechanism ensures that the workpiece does not lift during operations
 - ❸ Clamping force preadjustable with the aid of graduation lines
 - ❹ The mechanical Booster ensures that during extreme operations a constant high clamping-force up to 6500 kg can be reached
 - ❺ All working parts are hardened and grinded
-
- ❶ Unique système de mâchoire de serrage pour l'augmentation de la tension du ressort
 - ❷ Le nouveau mécanisme Anti-Lift assure un usinage sans problème et sans enlèvement de la pièce
 - ❸ La tension du ressort se fait par pré réglage avec marquage
 - ❹ Le répéteur de la tension du ressort assure que durant un usinage extrême la tension reste constante jusqu'à 6500 kg
 - ❺ Toutes les pièces d'usure sont trempées et meulées

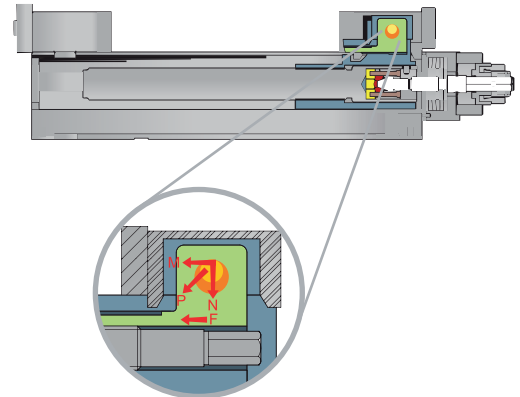

Durch das neue Anti-Lift-System werden die Werkstücke beim Spannen niedergezogen und präzise gespannt

By the new Anti-lift-system workpieces get pulled-down and precisely clamped

Par le nouveau système Anti-Lift les pièces sont baissées et serrées précisément

Allseitig gehärtet und geschliffen
All-round hardened and grinded
Complètement trempés et meulés

Stabiler Späneschutz
Solid chip protector
Protection résistant contre copeau

Spannkraft voreinstellbar
Clamping force preadjustable
Tension du ressort ajustable d'avance

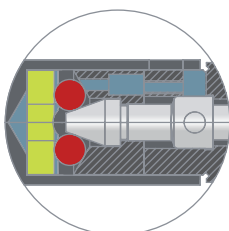
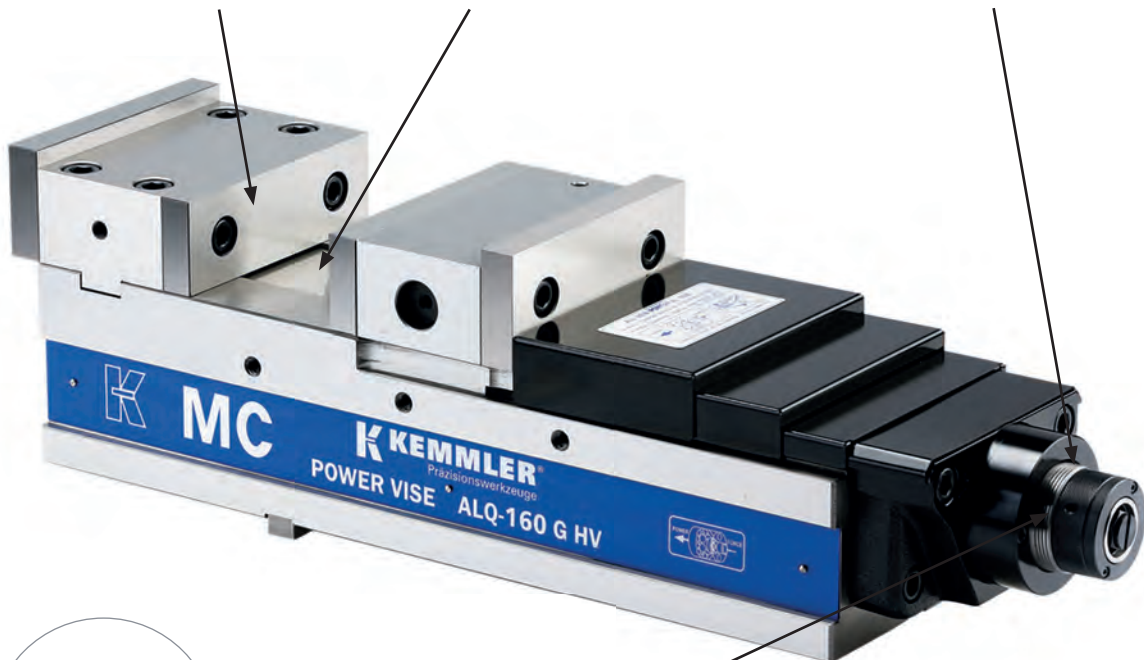

Mechanischer Spannkraftverstärker
Mechanical Booster
Répéteur de la tension du ressort

Index
Sommaire

11.05	11.06	11.07	11.08
11.09	11.10	11.11	11.12
11.13	11.14	11.15	11.16
11.17	11.19	11.20	11.21
11.22	11.23	11.24	11.25
11.27	11.29	11.31	11.35
11.36	11.37	11.39	11.39
11.40			

Precision vices mechanical with mechanical booster

Étaux de précision mécanique avec répéteur de la tension du ressort

Ausführung:

- Mit mechanischem Spannkraftverstärker
- Spannkraft voreinstellbar durch Rillenmarkierung
- Horizontal, vertikal oder seitlich aufspannbar
- Stahlkörper allseitig geschliffen und gehärtet
- Eingebauter Niederzug
- Betthöhe H: $\leq 0,01$ mm

Lieferumfang:

- Bedienungsanleitung
- Incl. Spannschlüssel
- 4 Stück Spannpratzen
- 4 Stück T-Nutensteine 18mm
- Messprotokoll

Spannkraft:

KS01010 = 57 kN
KS01020 = 67 kN

Construction:

- With mechanical booster
- Clamping force preadjustable by graduation lines
- Clamping positions: horizontal, vertical and lateral
- The steel body is hardened and grinded all-round
- Integrated pull-down mechanism
- Bed height H: $\leq 0,01$ mm

Delivery:

- Instructions for use
- Wrench
- 4 pcs. vice clamps
- 4 pcs. T-nuts 18mm
- Test certificate

Clamping force:

KS01010 = 57 kN
KS01020 = 67 kN

Type:

- Avec répéteur de la tension du ressort
- La tension du ressort ce fait par pré réglage avec marquage.
- Positions de serrage: horizontale, verticale ou latérale
- Corps en acier trempé et rectifié sur toutes les faces
- Répression basse incorporée
- Hauteur du socle H: $\leq 0,01$ mm

Livraison avec:

- Mode d'emploi
- Clé de serrage
- 4 Mors de serrage
- 4 Tasseaux pour rainures en T 18mm
- Protocole de mesure

Tension du ressort:

KS01010 = 57 kN
KS01020 = 67 kN

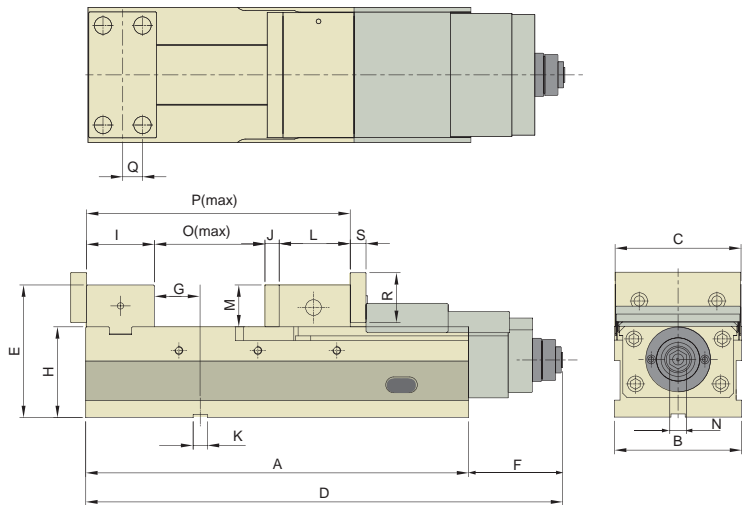
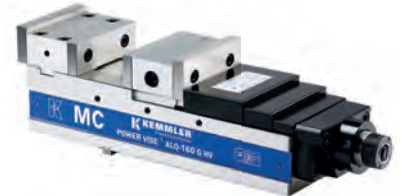
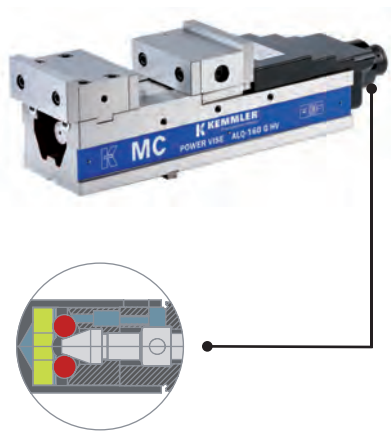

Mit patentiertem mechanischem Spannkraftverstärker:

- 1 kein Ölverlust
- 2 genaue Wiederholbarkeit der Spannkraft
- 3 keine Veränderung der Spannkraft
- 4 keine Vibrationen während der Bearbeitung
- 5 lange Lebensdauer

With patented mechanical booster:

- 1 no loss of oil
- 2 exact repeatability of the clamping force
- 3 constant clamping force
- 4 no vibrations during the operation
- 5 long life

Avec répéteur de la tension du ressort patenté:

- 1 pas de déchet d'huile hydraulique
- 2 répétabilité exacte de la tension du ressort
- 3 tension du ressort constante
- 4 pas de vibrations durant l'usinage
- 5 durabilité longue

Bestell-Nr. Order no. Référence	Ausführung Version Type	A	B	C	D	E	F	G	H	I	J	K	L	M	N	O	P	Q	R	S	kN	kg
KS01010	ALQ-160G/HV	515	161	159,5	635	168	120	76	115	86	18	18	80	53	19	330,0	514,0	25	63	20	57	76
KS01020	ALQ-200G/HV	585	202	200,0	713	178	128	93	120	101	18	18	95	58	19	367,5	581,5	31	73	20	67	108

Precision vices mechanical with mechanical booster

Étaux de précision mécanique avec répéteur de la tension du ressort

Ausführung:

- Mit mechanischem Spannkraftverstärker
- Spannkraft voreinstellbar durch Rillenmarkierung
- Horizontal, vertikal oder seitlich aufspannbar
- Stahlkörper allseitig geschliffen und gehärtet
- Eingebauter Niederzug
- Betthöhe H: $\leq 0,01$ mm

Lieferumfang:

- Bedienungsanleitung
- Incl. Spannschlüssel
- 4 Stück Spannpratzen
- 4 Stück T-Nutensteine 18mm
- Messprotokoll

Spannkraft:

KS02010 = 25 kN
 KS02020 = 35 kN
 KS02030 = 45 kN
 KS02040 = 50 kN

Construction:

- With mechanical booster
- Clamping force preadjustable by graduation lines
- Clamping positions: horizontal, vertical and lateral
- The steel body is hardened and grinded all-round
- Integrated pull-down mechanism
- Bed height H: $\leq 0,01$ mm

Delivery:

- Instructions for use
- Wrench
- 4 pcs. vice clamps
- 4 pcs. T-nuts 18mm
- Test certificate

Type:

- Avec répéteur de la tension du ressort
- La tension du ressort ce fait par pré réglage avec marquage.
- Positions de serrage: horizontale, verticale ou latérale
- Corps en acier trempé et rectifié sur toutes les faces
- Répression basse incorporée
- Hauteur du socle H: $\leq 0,01$ mm

Livraison avec:

- Mode d'emploi
- Clé de serrage
- 4 Mors de serrage
- 4 Tasseaux pour rainures en T 18mm
- Protocole de mesure

Clamping force:

KS02010 = 25 kN
 KS02020 = 35 kN
 KS02030 = 45 kN
 KS02040 = 50 kN

Tension du ressort:

KS02010 = 25 kN
 KS02020 = 35 kN
 KS02030 = 45 kN
 KS02040 = 50 kN

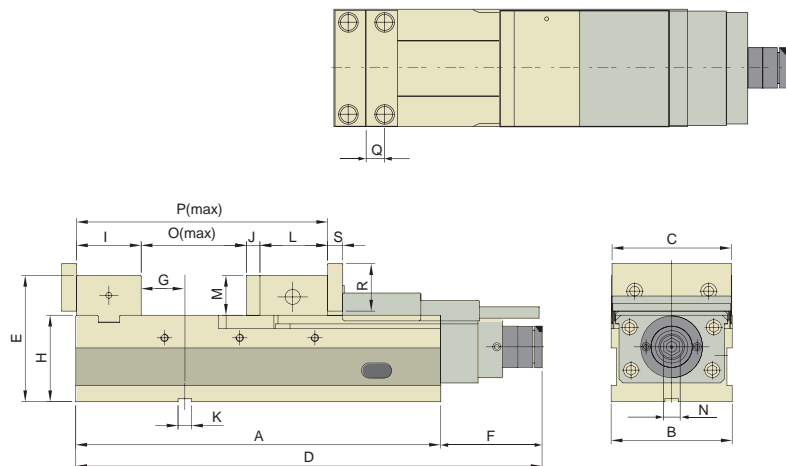
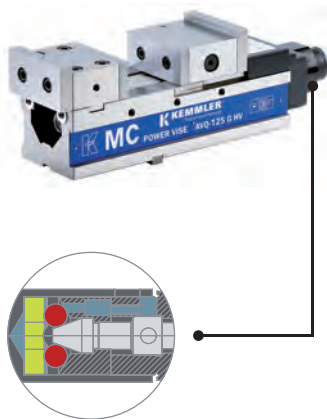

Mit patentiertem mechanischem Spannkraftverstärker:

- 1 kein Ölverlust
- 2 genaue Wiederholbarkeit der Spannkraft
- 3 keine Veränderung der Spannkraft
- 4 keine Vibrationen während der Bearbeitung
- 5 lange Lebensdauer

With patented mechanical booster:

- 1 no loss of oil
- 2 exact repeatability of the clamping force
- 3 constant clamping force
- 4 no vibrations during the operation
- 5 long life

Avec répéteur de la tension du ressort patenté:

- 1 pas de déchet d'huile hydraulique
- 2 répétabilité exacte de la tension du ressort
- 3 tension du ressort constante
- 4 pas de vibrations durant l'usinage
- 5 durabilité longue

Bestell-Nr. Order no. Référence	Ausführung Version Type	A	B	C	D	E	F	G	H	I	J	K	L	M	N	O	P	Q	R	S	kN	kg
KS02010	AVQ-100G/HV	324	104	102	428	130	104	41	85	73	15	18	86,5	45	14	140	314,5	20	55	17	25	30
KS02020	AVQ-125G/HV	390	127	125	495	153	105	66	100	78	15	18	87,5	53	14	201	381,5	22,5	63	20	35	46
KS02030	AVQ-160G/HV	485	161	159,5	605	168	120	58	115	86	18	18	80	53	14	295	479	25	63	20	45	71
KS02040	AVQ-200G/HV	535	202	200	655	178	128	75	120	101	18	18	95	58	14	320	534	31	73	20	50	100



Präzisionsschraubstöcke mechanisch mit Spannkraftverstärker

Precision vices mechanical with mechanical booster

Étaux de précision mécanique avec répéteur de la tension du ressort

Ausführung:

- Mit mechanischem Spannkraftverstärker
- Spannkraft voreinstellbar durch Rillenmarkierung
- Horizontal und vertikal aufspannbar
- Stahlkörper allseitig geschliffen und gehärtet
- Eingebauter Niederzug
- Betthöhe H: ≤ 0,01 mm

Lieferumfang:

- Bedienungsanleitung
- Incl. Spannschlüssel
- 4 Stück Spannpratzen
- 4 Stück T-Nutensteine 18mm
- Messprotokoll

Spannkraft:

KS14010 = 45 kN

Construction:

- With mechanical booster
- Clamping force preadjustable by graduation lines
- Clamping positions: horizontal and vertical
- The steel body is hardened and grinded all-round
- Integrated pull-down mechanism
- Bed height H: ≤ 0,01 mm

Delivery:

- Instructions for use
- Wrench
- 4 pcs. vice clamps
- 4 pcs. T-nuts 18mm
- Test certificate

Clamping force:

KS14010 = 45 kN

Type:

- Avec répéteur de la tension du ressort
- La tension du ressort ce fait par pré réglage avec marquage.
- Positions de serrage: horizontale ou verticale
- Corps en acier trempé et rectifié sur toutes les faces
- Répression basse incorporée
- Hauteur du socle H: ≤ 0,01 mm

Livraison avec:

- Mode d'emploi
- Clé de serrage
- 4 Mors de serrage
- 4 Tasseaux pour rainures en T 18mm
- Protocole de mesure

Tension du ressort:

KS14010 = 45 kN

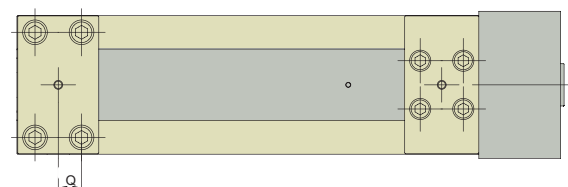
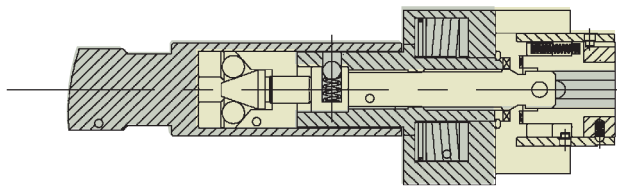
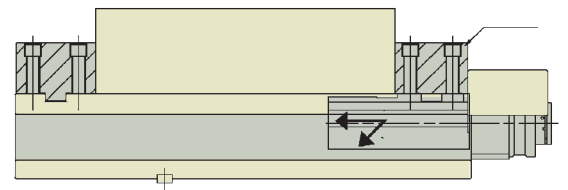
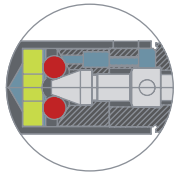

11

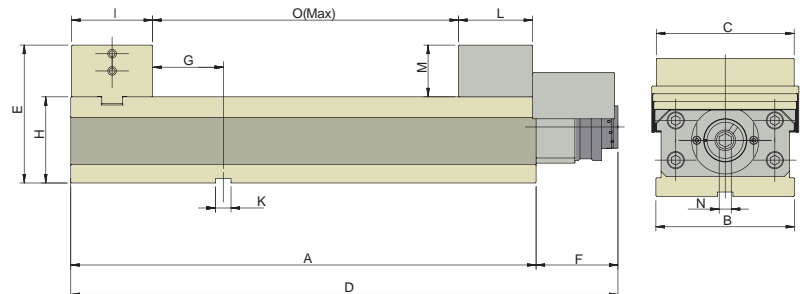

Bestell-Nr. Order no. Référence	Ausführung Version Type	A	B	C	D	E	F	G	H	I	K	M	N	O	Q	kN	kg
KS14010	AVK-160G/HV	540	161	160	635	160	95	82	100	94	18	60	14	355	27	45	65

Precision vices self-centering mechanical Étaux de précision etau autocentrant mécanique

Ausführung:

- Horizontal, vertikal oder seitlich aufspannbar
- Stahlkörper allseitig geschliffen und gehärtet
- Eingebauter Niederzug
- Betthöhe H: $\leq 0,01$ mm

Construction:

- Clamping positions: horizontal, vertical and lateral
- The steel body is hardened and grinded all-round
- Integrated pull-down mechanism
- Bed height H: $\leq 0,01$ mm

Type:

- Positions de serrage: horizontale, verticale ou latérale
- Corps en acier trempé et rectifié sur toutes les faces
- Répression basse incorporée
- Hauteur du socle H: $\leq 0,01$ mm

Lieferumfang:

- Bedienungsanleitung
- Incl. Spannschlüssel
- 4 Stück Spannpratzen
- 4 Stück T-Nutensteine 18mm
- Messprotokoll

Delivery:

- Instructions for use
- Wrench
- 4 pcs. vice clamps
- 4 pcs. T-nuts 18mm
- Test certificate

Livraison avec:

- Mode d'emploi
- Clé de serrage
- 4 Mors de serrage
- 4 Tasseaux pour rainures en T 18mm
- Protocole de mesure

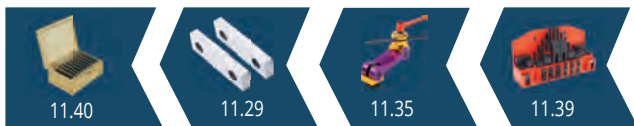
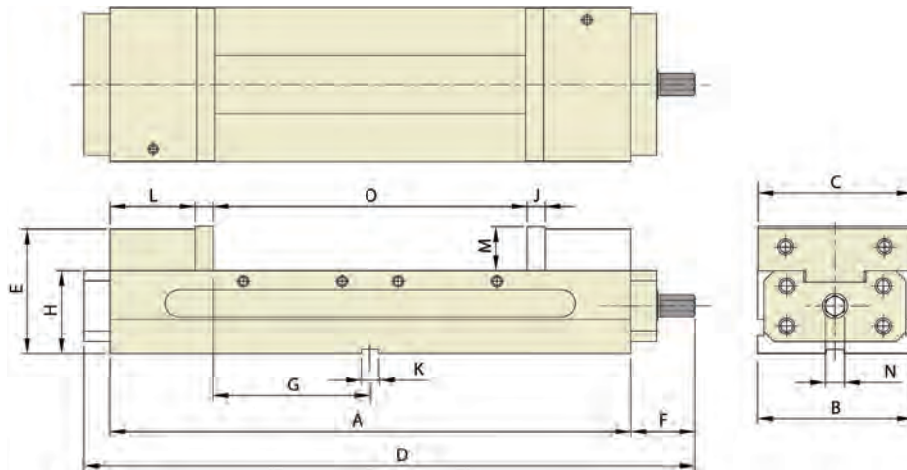

Bestell-Nr. Order no. Référence	Ausführung Version Type	A	B	C	D	E	F	G	H	J	K	L	M	N	O	T	U	kg
KS19010	HLD-60GG/HV	520	154	152	610	124,05	64	260	82,55	18	18	85	44,5	19	58-314	23,8	98,4	52



Präzisionsschraubstöcke mechanisch mit Spannkraftverstärker

Precision vices mechanical with mechanical booster
Étaux de précision mécanique avec répéteur de la tension du ressort

Ausführung:

- Mit mechanischem Spannkraftverstärker
- Spannkraft voreinstellbar durch Rillenmarkierung
- Horizontal, vertikal oder seitlich aufspannbar
- Stahlkörper allseitig geschliffen und gehärtet
- Eingebauter Niederzug
- Betthöhe H: ≤ 0,01 mm

Lieferumfang:

- Bedienungsanleitung
- Incl. Spannschlüssel
- 4 Stück Spannpratzen
- 4 Stück T-Nutensteine 18mm
- Messprotokoll

Spannkraft:

KS15010 = 45 kN
 KS15020 = 60 kN

Construction:

- With mechanical booster
- Clamping force preadjustable by graduation lines
- Clamping positions: horizontal, vertical and lateral
- The steel body is hardened and grinded all-round
- Integrated pull-down mechanism
- Bed height H: ≤ 0,01 mm

Delivery:

- Instructions for use
- Wrench
- 4 pcs. vice clamps
- 4 pcs. T-nuts 18mm
- Test certificate

Clamping force:

KS15010 = 45 kN
 KS15020 = 60 kN

Type:

- Avec répéteur de la tension du ressort
- La tension du ressort ce fait par préréglage avec marquage.
- Positions de serrage: horizontale, verticale ou latérale
- Corps en acier trempé et rectifié sur toutes les faces
- Répression basse incorporée
- Hauteur du socle H: ≤ 0,01 mm

Livraison avec:

- Mode d'emploi
- Clé de serrage
- 4 Mors de serrage
- 4 Tasseaux pour rainures en T 18mm
- Protocole de mesure

Tension du ressort:

KS15010 = 45 kN
 KS15020 = 60 kN

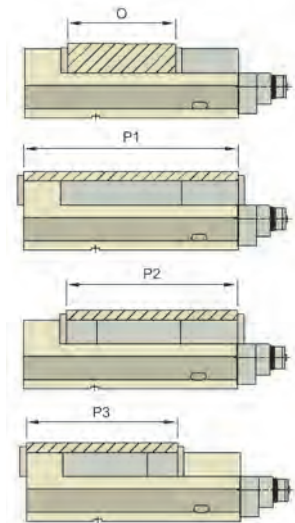
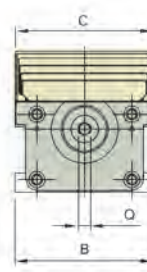
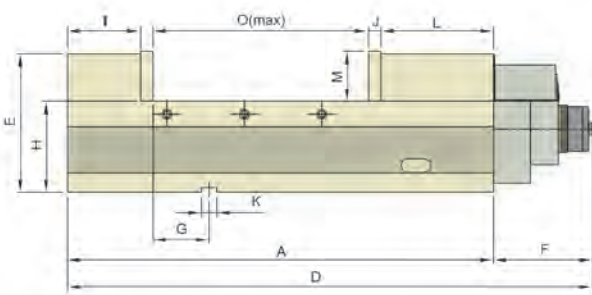
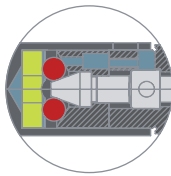
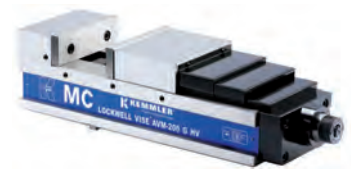
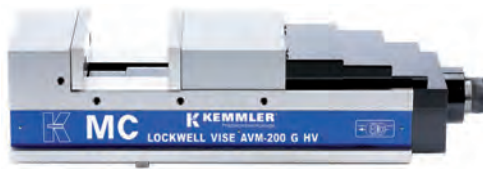

Bestell-Nr. Order no. Référence	Ausführung Version Type	A	B	C	D	E	F	G	H	I	J	K	L	M	N	O	P1	P2	P3	kN	kg
KS15010	AVM-160G/HV	495	161	160	610	160	115	65	105	85	15	18	130	58	19	250	250-480	250-370	250-330	45	55
KS15020	AVM-200G/HV	580	201	200	708	170	128	85	110	90	18	18	150	63	19	290	290-550	290-430	290-370	60	78



Precision vices mechanical Étaux de précision mécanique

Ausführung:

- Horizontal, vertikal oder seitlich aufspannbar
- Stahlkörper allseitig geschliffen und gehärtet
- Eingebauter Niederzug
- Betthöhe H: $\leq 0,01$ mm

Construction:

- Clamping positions: horizontal, vertical and lateral
- The steel body is hardened and grinded all-round
- Integrated pull-down mechanism
- Bed height H: $\leq 0,01$ mm

Type:

- Positions de serrage: horizontale, verticale ou latérale
- Corps en acier trempé et rectifié sur toutes les faces
- Répression basse incorporée
- Hauteur du socle H: $\leq 0,01$ mm

Lieferumfang:

- Bedienungsanleitung
- Incl. Spannschlüssel
- 4 Stück Spannpratzen
- 4 Stück T-Nutensteine 18mm
- Messprotokoll

Delivery:

- Instructions for use
- Wrench
- 4 pcs. vice clamps
- 4 pcs. T-nuts 18mm
- Test certificate

Livraison avec:

- Mode d'emploi
- Clé de serrage
- 4 Mors de serrage
- 4 Tasseaux pour rainures en T 18mm
- Protocole de mesure

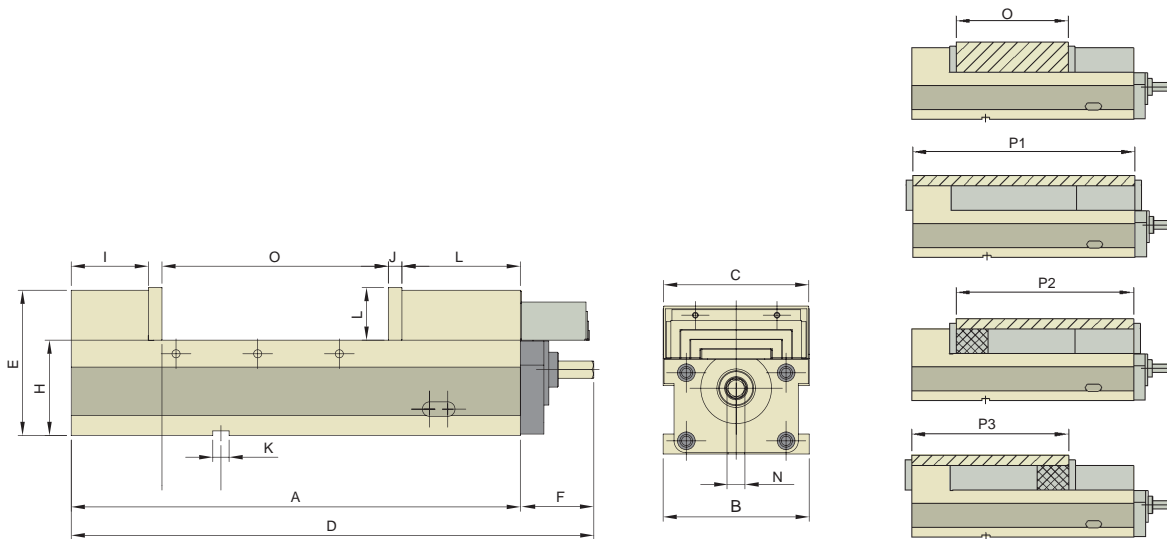

Bestell-Nr. Order no. Référence	Ausführung Version Type	A	B	C	D	E	F	G	H	I	J	K	L	M	N	O	P1	P2	P3	kg
KS16010	AVC-160G/HV	495	161	160	576	160	81	65	105	85	15	18	130	58	19	250	250-480	250-370	250-330	52
KS16020	AVC-200G/HV	580	201	200	670	170	90	85	110	90	18	18	130	63	19	250	290-550	290-430	290-370	75

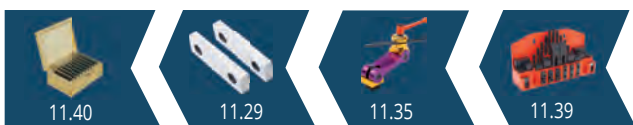

Precision vices mechanical Étaux de précision mécanique

Ausführung:

- Horizontal, vertikal oder seitlich aufspannbar
- Stahlkörper allseitig geschliffen und gehärtet
- Eingebauter Niederzug
- Betthöhe H: $\leq 0,01$ mm

Construction:

- Clamping positions: horizontal, vertical and lateral
- The steel body is hardened and grinded all-round
- Integrated pull-down mechanism
- Bed height H: $\leq 0,01$ mm

Type:

- Positions de serrage: horizontale, verticale ou latérale
- Corps en acier trempé et rectifié sur toutes les faces
- Répression basse incorporée
- Hauteur du socle H: $\leq 0,01$ mm

Lieferumfang:

- Bedienungsanleitung
- Incl. Spannschlüssel
- 4 Stück Spannpratzen
- 4 Stück T-Nutensteine 18mm
- Messprotokoll

Delivery:

- Instructions for use
- Wrench
- 4 pcs. vice clamps
- 4 pcs. T-nuts 18mm
- Test certificate

Livraison avec:

- Mode d'emploi
- Clé de serrage
- 4 Mors de serrage
- 4 Tasseaux pour rainures en T 18mm
- Protocole de mesure

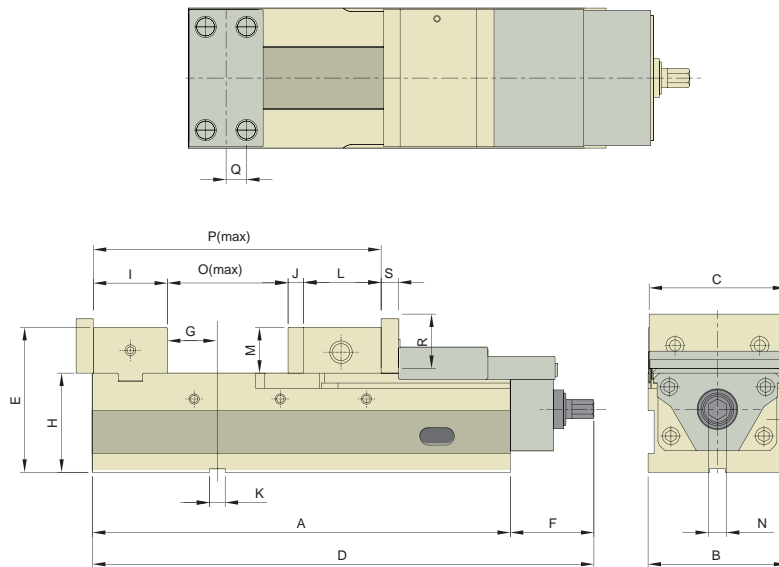

Bestell-Nr. Order no. Référence	Ausführung Version Type	A	B	C	D	E	F	G	H	I	J	K	L	M	N	O	P	Q	R	S	kg
KS05010	AVL-100G/HV	324	104	102,0	437	130	104	41	85	73	15	18	86,5	45	19	140	314,5	20,0	55	17	27
KS05020	AVL-125G/HV	390	127	125,0	480	153	105	66	100	78	15	18	87,5	53	19	201	381,5	22,5	63	20	43
KS05030	AVL-160G/HV	485	161	159,5	625	168	120	76	115	86	18	18	80,0	53	21	295	479,0	25,0	63	20	71
KS05040	AVL-200G/HV	535	202	199,5	660	178	128	93	120	101	18	18	95,0	58	19	320	534,0	31,0	73	20	98



Precision vices pneumatic hydraulic Étaux de précision pneumatiques hydrauliques

Ausführung:

- Geeignet für Serienfertigung
- Horizontal und vertikal aufspannbar
- Stahlkörper allseitig geschliffen und gehärtet
- Eingebauter Niederzug
- Betthöhe H: $\leq 0,01$ mm

Lieferumfang:

- Bedienungsanleitung
- Incl. Spannschlüssel
- 4 Stück Spannpratzen
- 4 Stück T-Nutensteine 18mm
- Messprotokoll

Construction:

- Suitable for mass production
- Clamping positions: horizontal and vertical
- The steel body is hardened and grinded all-round
- Integrated pull-down mechanism
- Bed height H: $\leq 0,01$ mm

Delivery:

- Instructions for use
- Wrench
- 4 pcs. vice clamps
- 4 pcs. T-nuts 18mm
- Test certificate

Type:

- Approprié à la fabrication en série
- Positions de serrage: horizontale, ou verticale
- Corps en acier trempé et rectifié sur toutes les faces
- Répression basse incorporée
- Hauteur du socle H: $\leq 0,01$ mm

Livraison avec:

- Mode d'emploi
- Clé de serrage
- 4 Mors de serrage
- 4 Tasseaux pour rainures en T 18mm
- Protocole de mesure

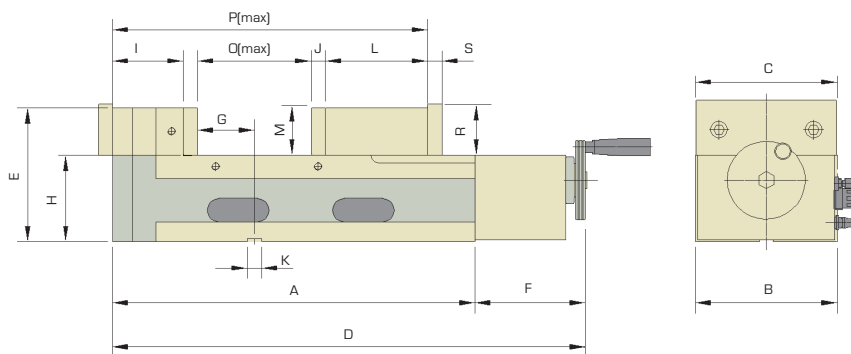
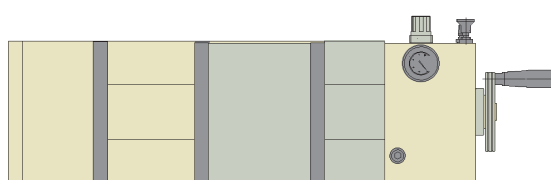
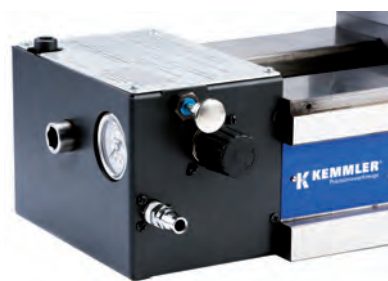
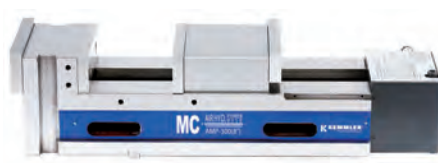

Bestell-Nr. Order no. Référence	Ausführung Version Type	A	B	C	D	E	F	G	H	I	J	K	L	M	N	O	P	R	S	kN	kg
KS18150	AMP-150G/HV	380	130	130	520	157	140	60	105	85	15	18	110	52	-	0-150	200-380	62	15	62	52
KS18160	AMP-160G/HV	400	160	160	540	157	140	60	105	87	15	18	120	52	-	0-160	210-400	62	15	62	58
KS18165	AMP-165G/HV	490	160	160	630	157	140	60	105	87	15	18	120	55	-	0-250	210-490	65	15	62	65
KS18180	AMP-180G/HV	460	180	180	600	170	140	90	110	90	18	18	130	60	-	0-200	220-460	70	18	90	75
KS18200	AMP-200G/HV	470	200	200	610	170	140	90	110	90	18	18	140	60	-	0-200	230-470	70	18	90	82
KS18300	AMP-300G/HV	570	200	200	710	170	140	90	110	90	18	18	140	60	-	0-300	230-570	70	18	90	93



K Doppelspannstöcke mechanisch

Twin vices mechanical Étaux à double serrage mécanique

Ausführung:

- Doppelspannung mit 2 beweglichen und einer festen Spannbacke
- Horizontal und vertikal aufspannbar
- Stahlkörper allseitig geschliffen und gehärtet
- Eingebauter Niederzug
- Spannwiederholgenauigkeit $\leq 0,01$ mm
- Mittenspanngenauigkeit $\leq 0,01$ mm
- Betthöhe H: $\leq 0,01$ mm

Construction:

- Double-clamping via two mobile and one fixed jaw.
- Clamping positions: horizontal, and vertical
- The steel body is hardened and grinded all-round
- Integrated pull-down mechanism
- Repeating accuracy $\leq 0,01$ mm
- Clamping accuracy at the centre $\leq 0,01$ mm
- Bed height H: $\leq 0,01$ mm

Type:

- Double serrage avec deux mâchoires mobile et une mâchoire fixe
- Positions de serrage: horizontale, ou verticale
- Corps en acier trempé et rectifié sur toutes les faces
- Répression basse incorporée
- Précision de la répétition $\leq 0,01$ mm
- Précision de la répétition au centre $\leq 0,01$ mm
- Hauteur du socle H: $\leq 0,01$ mm

Lieferumfang:

- Bedienungsanleitung
- Incl. Spannschlüssel
- 4 Stück Spannpratzen
- 4 Stück T-Nutensteine 18mm
- Messprotokoll

Delivery:

- Instructions for use
- Wrench
- 4 pcs. vice clamps
- 4 pcs. T-nuts 18mm
- Test certificate

Livraison avec:

- Mode d'emploi
- Clé de serrage
- 4 Mors de serrage
- 4 Tasseaux pour rainures en T 18mm
- Protocole de mesure

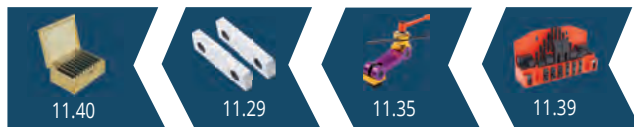
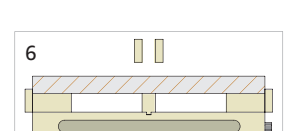
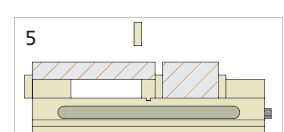
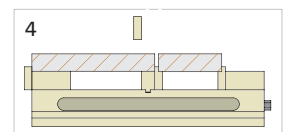
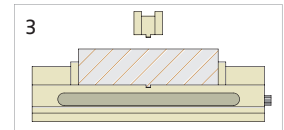
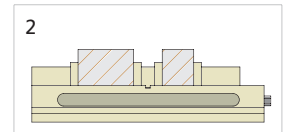
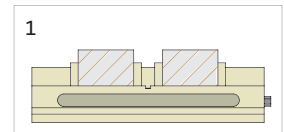
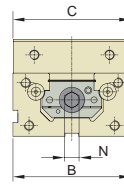
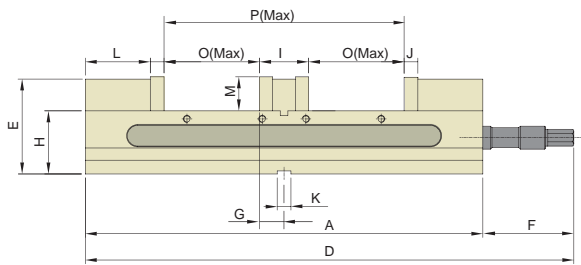
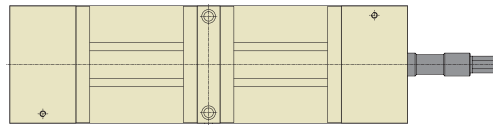
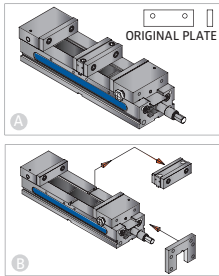

Bestell-Nr. Order no. Référence	Ausführung Version Type	A	B	C	D	E	F	G	H	I	J	K	L	M	N	O	P	kg
KS09010	TLD-40G/HV	405	104	103	459	96,5	54	27,5	63,50	55	15	18	69	38,0	14	90	235	20
KS09020	TLD-60G/HV	520	154	153	536	124,05	16	33,0	82,55	66	18	18	86,5	44,5	19	125	316	52

Twin vices mechanical Étaux à double serrage mécanique

Ausführung:

- Doppelspannung mit 2 beweglichen und einer festen Spannbacke
- Horizontal und vertikal aufspannbar
- Stahlkörper allseitig geschliffen und gehärtet
- Eingebauter Niederzug
- Spannwiederholgenauigkeit $\leq 0,01$ mm
- Mittenspanngenauigkeit $\leq 0,01$ mm
- Betthöhe H: $\leq 0,01$ mm

Construction:

- Double-clamping via two mobile and one fixed jaw
- Clamping positions: horizontal and vertical
- The steel body is hardened and grinded all-round
- Integrated pull-down mechanism
- Repeating accuracy $\leq 0,01$ mm
- Clamping accuracy at the centre $\leq 0,01$ mm
- Bed height H: $\leq 0,01$ mm

Type:

- Double serrage avec deux mâchoires mobile et une mâchoire fixe
- Positions de serrage: horizontale ou verticale
- Corps en acier trempé et rectifié sur toutes les faces
- Répression basse incorporée
- Précision de la répétition $\leq 0,01$ mm
- Précision de la répétition au centre $\leq 0,01$ mm
- Hauteur du socle H: $\leq 0,01$ mm

Lieferumfang:

- Bedienungsanleitung
- Incl. Spannschlüssel
- 4 Stück Spannpratzen
- 4 Stück T-Nutensteine 18mm
- Messprotokoll

Delivery:

- Instructions for use
- Wrench
- 4 pcs. vice clamps
- 4 pcs. T-nuts 18mm
- Test certificate

Livraison avec:

- Mode d'emploi
- Clé de serrage
- 4 Mors de serrage
- 4 Tasseaux pour rainures en T 18mm
- Protocole de mesure

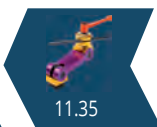
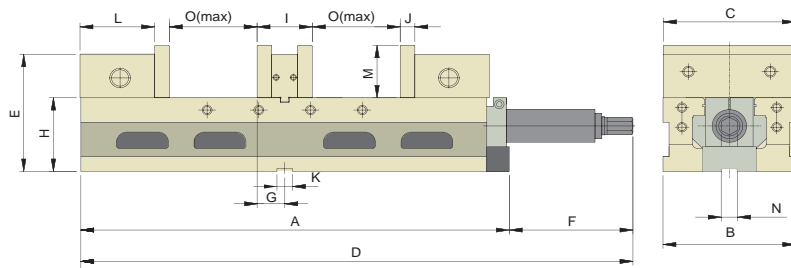
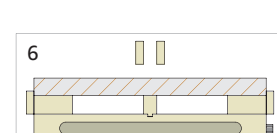
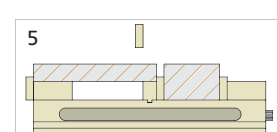
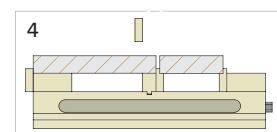
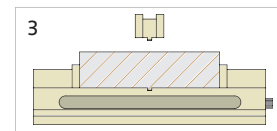
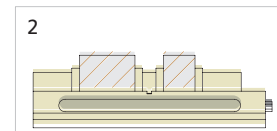
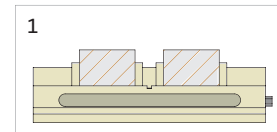
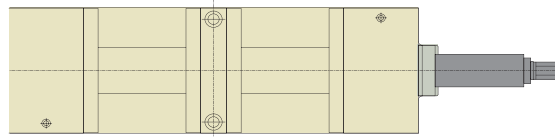
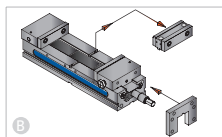
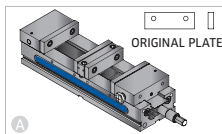
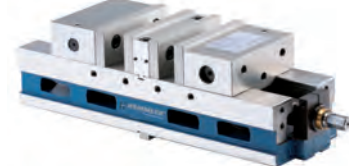
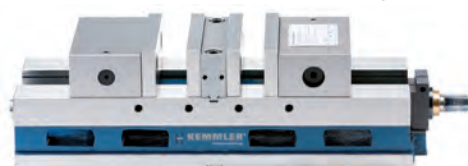

Bestell-Nr. Order no. Référence	Ausführung Version Type	A	B	C	D	E	F	G	H	I	J	K	L	M	N	O	kg
KS10010	ALD-60G/HV	497	154	152	610	143	113	32	90	64	17	18	86,5	58	14	34-102	63,5

K 5-Achs Maschinen-Schraubstöcke

5-Axis-Machine vices Étaux à 5-axes

Ausführung:

- Horizontal, vertikal oder seitlich aufspannbar
- Stahlkörper allseitig geschliffen und gehärtet
- Eingebauter Niederzug
- Betthöhe H: $\leq 0,01$ mm

Construction:

- Clamping positions: horizontal, vertical and lateral
- The steel body is hardened and grinded all-round
- Integrated pull-down mechanism
- Bed height H: $\leq 0,01$ mm

Type:

- Positions de serrage: horizontale, verticale ou latérale
- Corps en acier trempé et rectifié sur toutes les faces
- Répression basse incorporée
- Hauteur du socle H: $\leq 0,01$ mm

Lieferumfang:

- Bedienungsanleitung
- Incl. Spannschlüssel
- 4 Stück Spannpratzen
- 4 Stück T-Nutensteine 18mm
- Messprotokoll

Delivery:

- Instructions for use
- Wrench
- 4 pcs. vice clamps
- 4 pcs. T-nuts 18mm
- Test certificate

Livraison avec:

- Mode d'emploi
- Clé de serrage
- 4 Mors de serrage
- 4 Tasseaux pour rainures en T 18mm
- Protocole de mesure

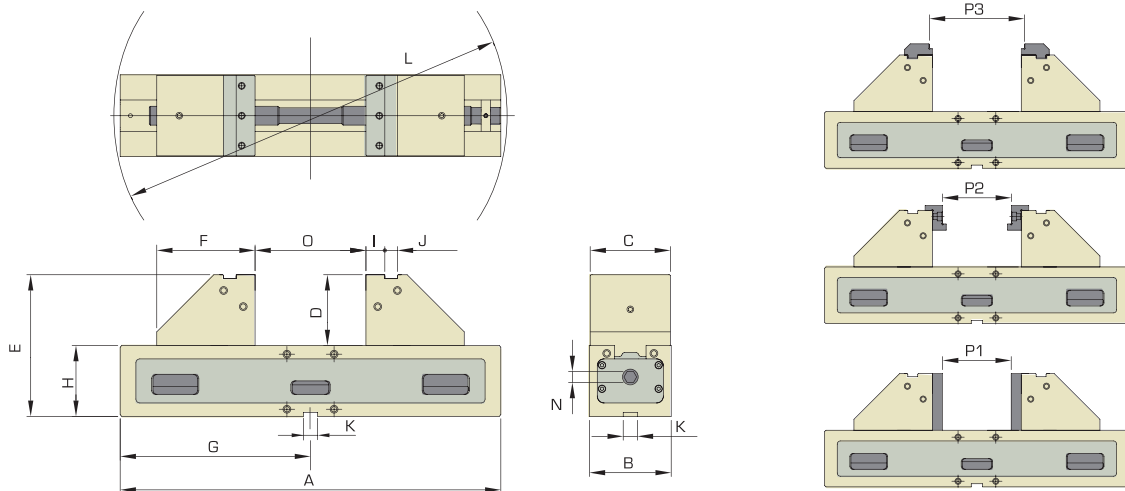

11



Bestell-Nr. Order no. Référence	Ausführung Version Type	A	B	C	D	E	F	G	H	I	J	K	L	N	O	P1	P2	P3	KN	kg
KS20100	ALT-100M	324	104	102	90	180	125	162	90	24	16	18	350	14	74	44	42	84	20	20
KS20101	ALT-100L	484	104	102	90	180	125	242	90	24	16	18	500	14	184	102	200	240	20	30

mechanisch mit Spannkraftverstärker

5-Axis precision vice AEX 125G mechanical with mechanical booster

5-axes Étau de précision AEX 125G mécanique avec répeteur de la tension du ressort

Ausführung:

- Mit mechanischem Spannkraftverstärker
- Spannkraft voreinstellbar durch Rillenmarkierung
- Eingebauter Niederzug
- Betthöhe H: ≤ 0,01 mm

Lieferumfang:

- Bedienungsanleitung
- Incl. Spannschlüssel
- 4 Stück Spannpratzen
- 4 Stück T-Nutensteine 14mm
- Messprotokoll

Spannkraft:

KS20200 = 40 kN

Construction:

- With mechanical booster
- Clamping force preadjustable by graduation lines
- Integrated pull-down mechanism
- Bed height H: ≤ 0,01 mm

Delivery:

- Instructions for use
- Wrench
- 4 pcs. vice clamps
- 4 pcs. T-nuts 14mm
- Test certificate

Clamping force:

KS20200 = 40 kN

Type:

- Avec répeteur de la tension du ressort
- La tension du ressort ce fait par pré réglage avec marquage.
- Répression basse incorporée
- Hauteur du socle H: ≤ 0,01 mm

Livraison avec:

- Mode d'emploi
- Clé de serrage
- 4 Mors de serrage
- 4 Tasseaux pour rainures en T 14mm
- Protocole de mesure

Tension du ressort:

KS20200 = 40 kN

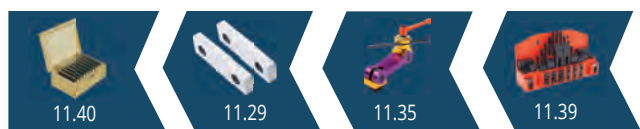
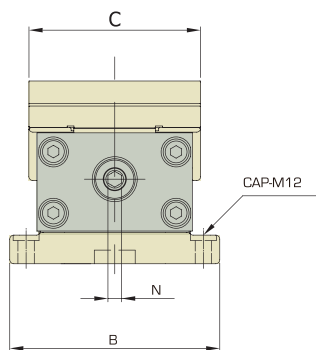
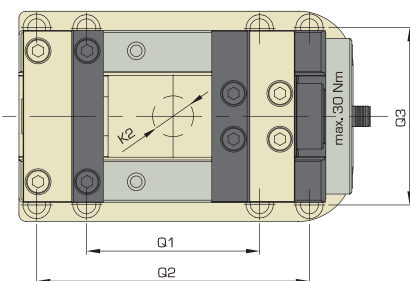
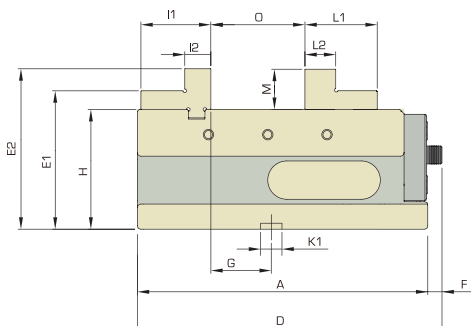
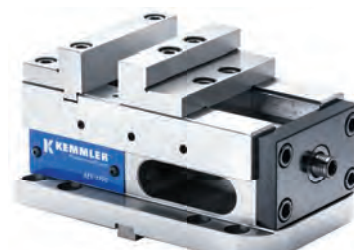

Bestell-Nr. Order no. Référence	Ausführung Version Type	A	B	C	D	E	E1	E2	F	G	H	I1	I2	K1	K2	L1	L2	M	N	O	Q1	Q2	Q3	kN	kg
KS20200	AEX 125G	245	154	126	257	34	116	134	12	51	100	59	22	18	ø30	61	26	34	10	102	127	200	130	40	20



Mehrfachspannsystem 3-teilig

Multiple Clamping System 3-parts
Système multiple de serrage 3-pièces

Ausführung:

- Mit mechanischem Spannkraftverstärker
- Spannkraft voreinstellbar durch Rillenmarkierung
- Stahlkörper allseitig geschliffen und gehärtet
- Eingebauter Niederzug
- Betthöhe H: $\leq 0,01$ mm

Construction:

- With mechanical booster
- Clamping force preadjustable by graduation lines
- The steel body is hardened and grinded all-round
- Integrated pull-down mechanism
- Bed height H: $\leq 0,01$ mm

Type:

- Avec répéteur de la tension du ressort
- La tension du ressort ce fait par préréglage avec marquage.
- Corps en acier trempé et rectifié sur toutes les faces
- Répression basse incorporée
- Hauteur du socle H: $\leq 0,01$ mm

Lieferumfang:

- Bedienungsanleitung
- Incl. Spannschlüssel
- 4 Stück Spannpratzen
- 4 Stück T-Nutensteine 18mm
- Messprotokoll

Delivery:

- Instructions for use
- Wrench
- 4 pcs. vice clamps
- 4 pcs. T-nuts 18mm
- Test certificate

Livraison avec:

- Mode d'emploi
- Clé de serrage
- 4 Mors de serrage
- 4 Tasseaux pour rainures en T 18mm
- Protocole de mesure

Spannkraft:

KS22020 = 50 kN

Clamping force:

KS22020 = 50 kN

Tension du ressort:

KS22020 = 50 kN

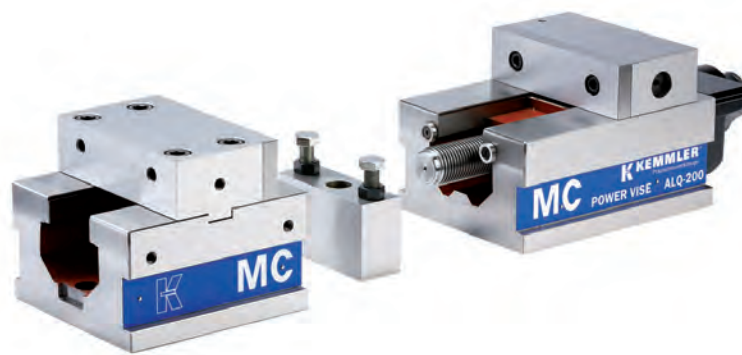

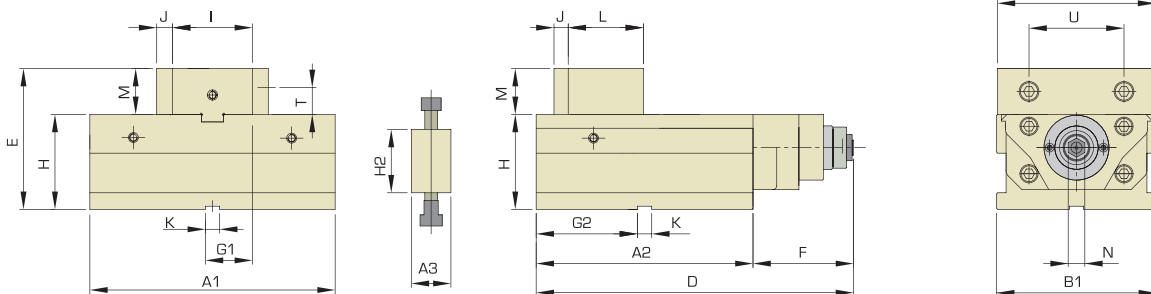
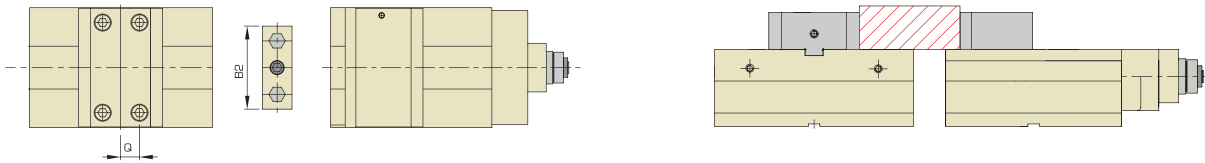
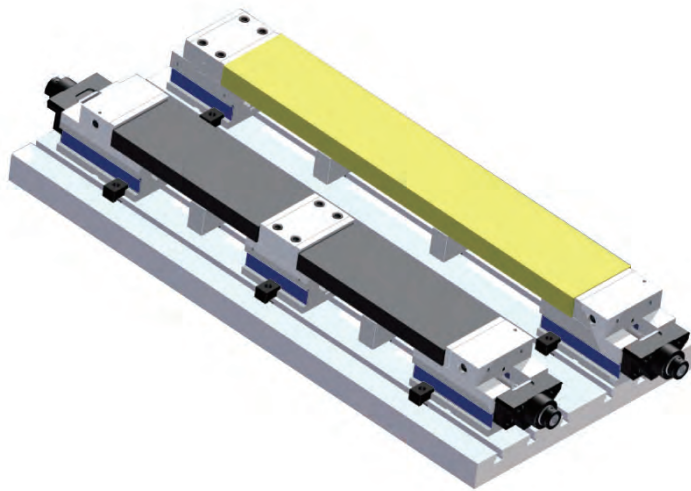
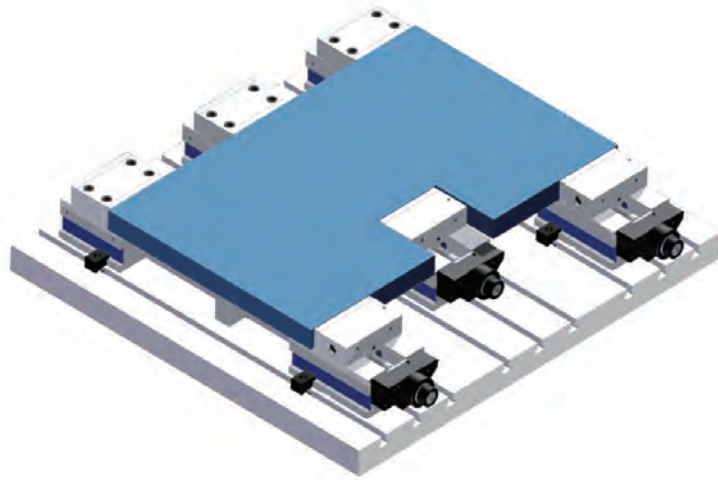

Bestell-Nr. Order no. Référence	Ausführung Version Type	A1	A2	A3	B1	B2	C	D	E	F	G1	G2	H	I	J	K	L	M	N	Q	T	U	KN	kg
KS22020	AOM-200/HV	210	270	50	202	140	199,5	398	178	128	59,5	126	120	101	18	18	95	58	19	31	29	120	50	95

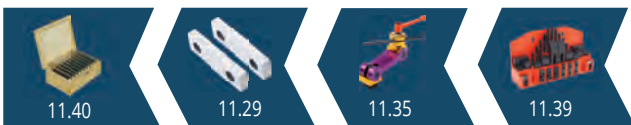



Präzisionsschraubstöcke mechanisch

Precision vices mechanical Étaux de précision mécanique

Ausführung:

- Horizontal, vertikal oder seitlich aufspannbar
- Stahlkörper allseitig geschliffen und gehärtet
- Eingebauter Niederzug
- Betthöhe H: ≤ 0,01 mm

Construction:

- Clamping positions: horizontal, vertical and lateral
- The steel body is hardened and grinded all-round
- Integrated pull-down mechanism
- Bed height H: ≤ 0,01 mm

Type:

- Positions de serrage: horizontale, verticale ou latérale
- Corps en acier trempé et rectifié sur toutes les faces
- Répression basse incorporée
- Hauteur du socle H: ≤ 0,01 mm

Lieferumfang:

- Bedienungsanleitung
- Incl. Spannschlüssel
- 4 Stück Spannspratzen
- 4 Stück T-Nutensteine 18mm
- Messprotokoll

Delivery:

- Instructions for use
- Wrench
- 4 pcs. vice clamps
- 4 pcs. T-nuts 18mm
- Test certificate

Livraison avec:

- Mode d'emploi
- Clé de serrage
- 4 Mors de serrage
- 4 Tasseaux pour rainures en T 18mm
- Protocole de mesure

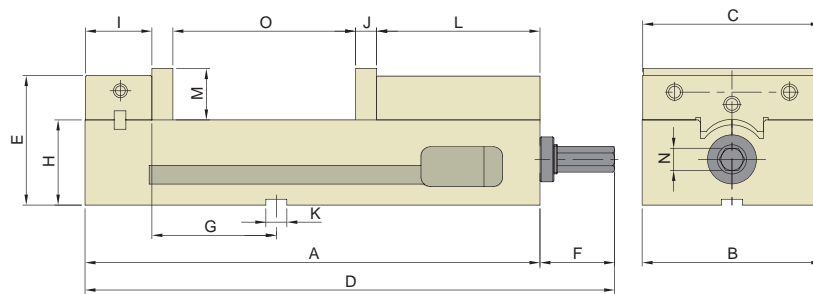

11

Bestell-Nr. Order no. Référence	Ausführung Version Type	A	B	C	D	E	F	G	H	I	J	K	L	M	N	O	kg
KS12010	AMC-40G/HV	330	105	102	372	100	42	82,6	68	46,8	21	18	106	40,0	14	125	21,0
KS12020	AMC-60G/HV	390	154	153	455	111	65	123	73	57,0	18	18	140	44,5	19	148	36,5



11.40



11.29



11.35



11.39

Precision vices mechanical
Étaux de précision mécanique

Ausführung:

- Horizontal und vertikal aufspannbar
- Stahlkörper geschliffen und gehärtet
- Eingebauter Niederzug
- Betthöhe H: ≤ 0,01 mm

Construction:

- Clamping positions: horizontal and vertical
- The steel body is hardened and grinded
- Integrated pull-down mechanism
- Bed height H: ≤ 0,01 mm

Type:

- Positions de serrage: horizontale ou verticale
- Corps en acier trempé et rectifié sur toutes
- Répression basse incorporée
- Hauteur du socle H: ≤ 0,01 mm

Lieferumfang:

- Bedienungsanleitung
- Incl. Spannschlüssel
- Messprotokoll

Delivery:

- Instructions for use
- Wrench
- Test certificate

Livraison avec:

- Mode d'emploi
- Clé de serrage
- Protocole de mesure

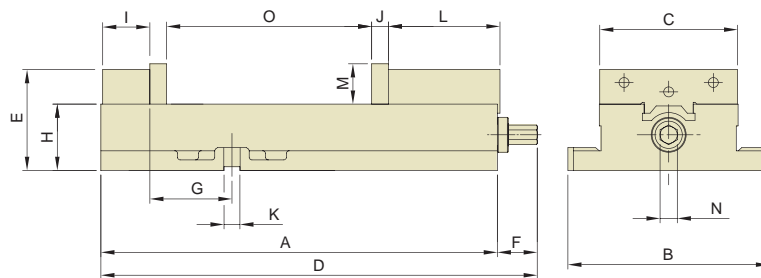
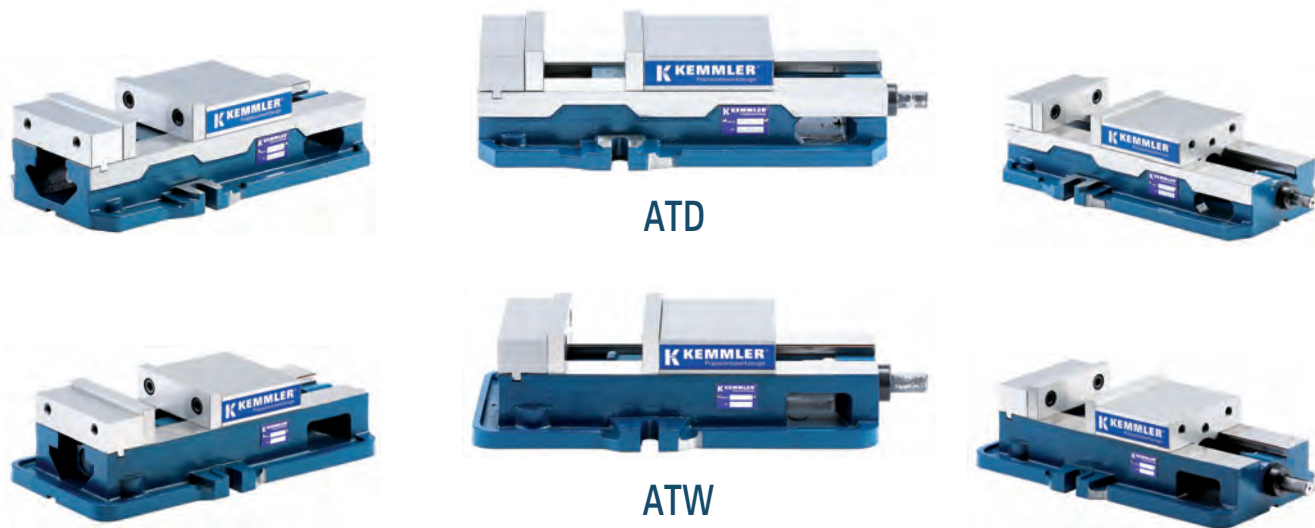

Bestell-Nr. Order no. Référence	Ausführung Version Type	A	B	C	D	E	F	G	H	I	J	K	L	M	N	O	kg
KS11010	ATD-460	312,5	166	103,5	352,5	85,65	40	71	57,15	35,1	15	12	102	35,0	14,0	103,9	18
KS11020	ATD-570	368,0	194	127,0	404,0	97,00	36	85	63,5	40,5	17	16	120	38,1	16,0	127,0	25
KS11030	ATW-675	432,0	235	152,0	476,0	111,02	44	108	73,02	52,0	18	20	123	44,5	19,0	192,0	36
KS11040	ATW-689	437	222	152	481,0	111,025	44	90,5	73,025	52	18	20	123	44,5	19,0	226,0	36
KS11050	ATW-810	555	295	203	585,0	134,074	30	125,7	84,074	58	24,2	20	157	56,0	19,0	265,0	68





Präzisionsschraubstöcke mechanisch

Precision vices mechanical Étaux de précision mécanique

Ausführung:

- Horizontal, vertikal oder seitlich aufspannbar
- Stahlkörper allseitig geschliffen und gehärtet
- Eingebauter Niederzug
- Betthöhe H: ≤ 0,01 mm

Construction:

- Clamping positions: horizontal, vertical and lateral
- The steel body is hardened and grinded all-round
- Integrated pull-down mechanism
- Bed height H: ≤ 0,01 mm

Type:

- Positions de serrage: horizontale, verticale ou latérale
- Corps en acier trempé et rectifié sur toutes les faces
- Répression basse incorporée
- Hauteur du socle H: ≤ 0,01 mm

Lieferumfang:

- Bedienungsanleitung
- Incl. Spannschlüssel
- 4 Stück Spannpratzen
- 4 Stück T-Nutensteine 18mm
- Messprotokoll

Delivery:

- Instructions for use
- Wrench
- 4 pcs. vice clamps
- 4 pcs. T-nuts 18mm
- Test certificate

Livraison avec:

- Mode d'emploi
- Clé de serrage
- 4 Mors de serrage
- 4 Tasseaux pour rainures en T 18mm
- Protocole de mesure

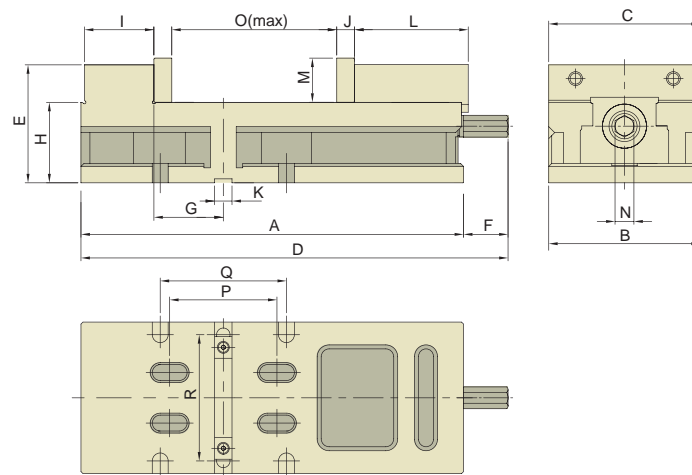

11

Bestell-Nr. Order no. Référence	Ausführung Version Type	A	B	C	D	E	F	G	H	I	J	K	L	M	N	O	P	Q	R	kg
KS13010	MG-60G/HV	385	152,45	152	431,8	118,7	46,8	61,1	81	69,9	18	18	114,3	44,5	19	163	107,95	127	127	31



11.40



11.29



11.35



11.39

Precision vices hydraulic Étaux de précision hydraulique

Ausführung:

- Spannkraft voreinstellbar durch Rillenmarkierung
- Horizontal und vertikal aufspannbar
- 50° schwenkbar
- Führungen geschliffen und gehärtet

Lieferumfang:

- Bedienungsanleitung
- Incl. Spannschlüssel
- Messprotokoll

Spannkraft:

KS08010 = 25 kN
KS08020 = 44 kN

Construction:

- Clamping force preadjustable by graduation lines
- Clamping positions: horizontal and vertical
- 50° pivotable
- Slides hardened and grinded

Delivery:

- Instructions for use
- Wrench
- Test certificate

Clamping force:

KS08010 = 25 kN
KS08020 = 44 kN

Type:

- La tension du ressort ce fait par pré réglage avec marquage
- Positions de serrage: horizontale ou verticale
- Pivotant de 50°
- Rainures trempées et rectifiées

Livraison avec:

- Mode d'emploi
- Clé de serrage
- Protocole de mesure

Tension du ressort:

KS08010 = 25 kN
KS08020 = 44 kN

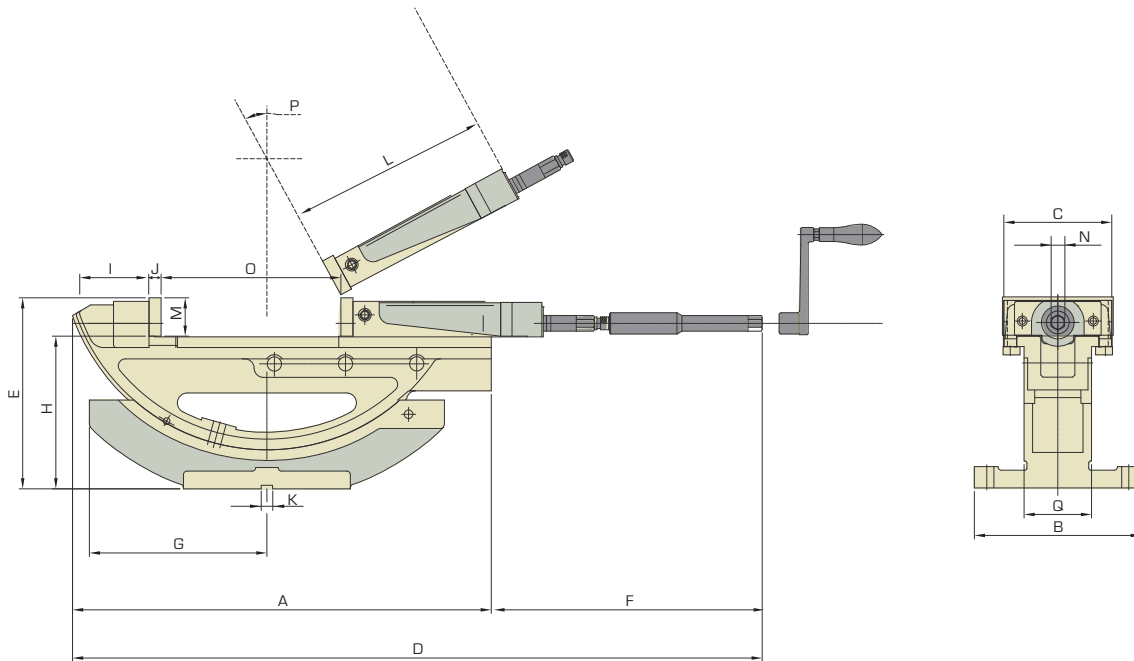

Bestell-Nr. Order no. Référence	Ausführung Version Type	A	B	C	D	Winkel E Angle E Angle E	F	G	H	I	J	K	L	M	N	O	P	Q	kN	kg
KS08010	HPT-40	330	160	104	525	177	195	172	141	65	11	16	153	36	14	170	50	65,0	25	28
KS08020	HPT-60	590	235	152	812	264	222	250	210	97	15	16	175	54	19	300	50	94,5	44	75

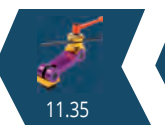



Präzisionsschraubstöcke mechanisch mit Spannkraftverstärker

Precision vices mechanical with mechanical booster

Étaux de précision mécanique avec répéteur de la tension du ressort

Ausführung:

- Mit mechanischem Spannkraftverstärker
- Spannkraft voreinstellbar durch Rillenmarkierung
- Horizontal und vertikal aufspannbar
- Führungen geschliffen und gehärtet
- Betthöhe H: $\leq 0,01$ mm

Lieferumfang:

- Bedienungsanleitung
- Incl. Spannschlüssel
- Messprotokoll

Spannkraft:

KS06010 = 40 kN
KS06020 = 50 kN
KS06030 = 60 kN

Construction:

- With mechanical booster
- Clamping force preadjustable by graduation lines
- Clamping positions: horizontal and vertical
- Slides hardened and grinded
- Bed height H: $\leq 0,01$ mm

Delivery:

- Instructions for use
- Wrench
- Test certificate

Clamping force:

KS06010 = 40 kN
KS06020 = 50 kN
KS06030 = 60 kN

Type:

- Avec répéteur de la tension du ressort
- La tension du ressort ce fait par pré réglage avec marquage.
- Positions de serrage: horizontale ou verticale
- Rainures trempées et rectifiées
- Hauteur du socle H: $\leq 0,01$ mm

Livraison avec:

- Mode d'emploi
- Clé de serrage
- Protocole de mesure

Tension du ressort:

KS06010 = 40 kN
KS06020 = 50 kN
KS06030 = 60 kN

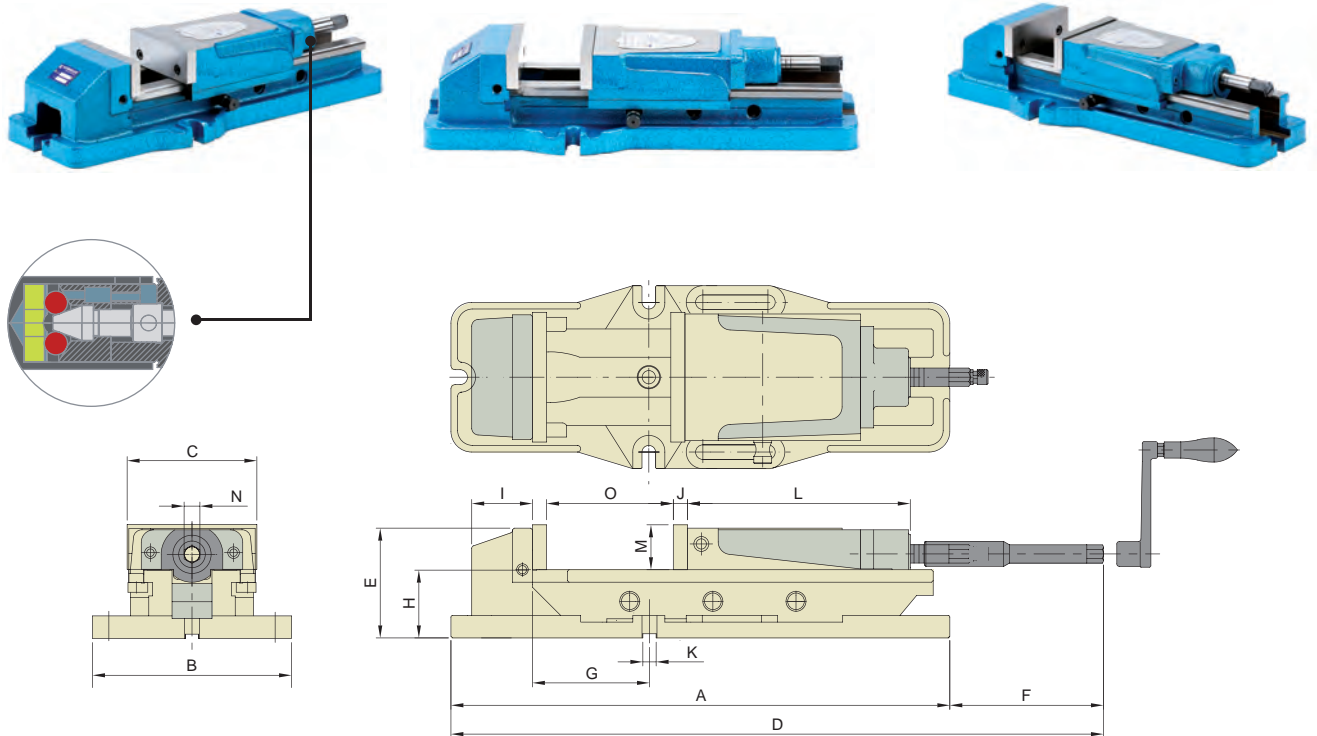

11

Mit patentiertem mechanischem Spannkraftverstärker:

- 1 kein Ölverlust
- 2 genaue Wiederholbarkeit der Spannkraft
- 3 keine Veränderung der Spannkraft
- 4 keine Vibrationen während der Bearbeitung
- 5 lange Lebensdauer

With patented mechanical booster:

- 1 no loss of oil
- 2 exact repeatability of the clamping force
- 3 constant clamping force
- 4 no vibrations during the operation
- 5 long life

Avec répéteur de la tension du ressort patenté:

- 1 pas de déchet d'huile hydraulique
- 2 répétabilité exacte de la tension du ressort
- 3 tension du ressort constante
- 4 pas de vibrations durant l'usinage
- 5 durabilité longue

Bestell-Nr. Order no. Référence	Ausführung Version Type	A	B	C	D	E	F	G	H	I	J	K	L	M	N	O	kN	kg
KS06010	MP-50A	538	185	130	670	117	132	82	72	76	15	16	175	46	19	220	40	38
KS06020	MP-60A	620	240	154	800	132	180	140	82	82	17	16	208	54	19	300	50	58
KS06030	MP-80A	700	280	206	900	160	200	118	100	100	21	18	245	62	19	300	60	104

Precision vices hydraulic Étaux de précision hydraulique

Ausführung:

- Spannkraft voreinstellbar durch Rillenmarkierung
- Horizontal und vertikal aufspannbar
- Führungen geschliffen und gehärtet
- Eingebauter Niederzug
- Betthöhe H: $\leq 0,01$ mm

Lieferumfang:

- Bedienungsanleitung
- Incl. Spannschlüssel
- Messprotokoll

Spannkraft:

KS07010 = 25 kN
KS07020 = 35 kN
KS07030 = 44 kN
KS07040 = 66 kN

Construction:

- Clamping force preadjustable by graduation lines
- Clamping positions: horizontal and vertical
- Slides hardened and grinded
- Integrated pull-down mechanism
- Bed height H: $\leq 0,01$ mm

Delivery:

- Instructions for use
- Wrench
- Test certificate

Clamping force:

KS07010 = 25 kN
KS07020 = 35 kN
KS07030 = 44 kN
KS07040 = 66 kN

Type:

- La tension du ressort ce fait par pré réglage avec marquage.
- Positions de serrage: horizontale, ou verticale
- Rainures trempées et rectifiées
- Répression basse incorporée
- Hauteur du socle H: $\leq 0,01$ mm

Livraison avec:

- Mode d'emploi
- Clé de serrage
- Protocole de mesure

Tension du ressort:

KS07010 = 25 kN
KS07020 = 35 kN
KS07030 = 44 kN
KS07040 = 66 kN

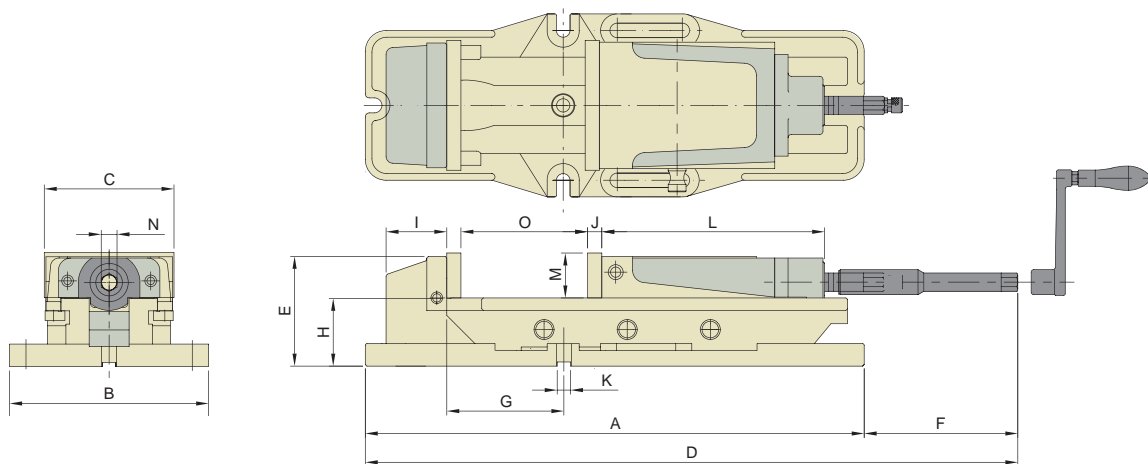
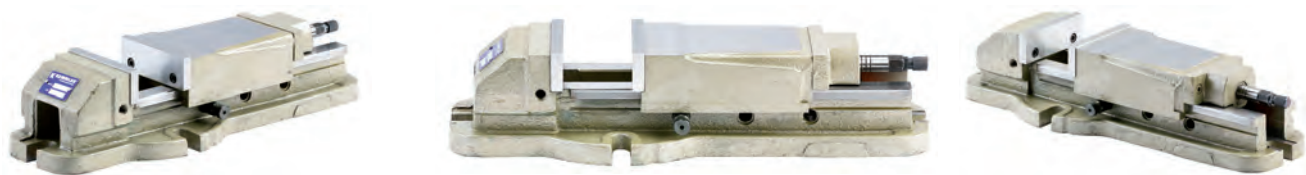

Bestell-Nr. Order no. Référence	Ausführung Version Type	A	B	C	D	E	F	G	H	I	J	K	L	M	N	O	kN	kg
KS07010	HP-40A	435	160	104	525	93	90	53	58	76	11	16	153	36	14	170	25	24
KS07020	HP-50A	538	185	130	670	117	132	82	72	82	15	16	175	46	19	220	35	37
KS07030	HP-60A	620	240	154	800	132	180	140	82	81	17	16	208	54	19	300	44	58
KS07040	HP-80A	700	280	206	900	160	200	118	100	101	21	18	245	62	19	300	66	104



Präzisionsschraubstöcke mechanisch

Precision vices mechanical Étaux de précision mécanique

Ausführung:

- Horizontal, vertikal oder seitlich aufspannbar
- Stahlkörper allseitig geschliffen und gehärtet
- Betthöhe H: $\leq 0,01$ mm

Construction:

- Clamping positions: horizontal, vertical and lateral
- The steel body is hardened and grinded all-round
- Bed height H: $\leq 0,01$ mm

Type:

- Positions de serrage: horizontale, verticale ou latérale
- Corps en acier trempé et rectifié sur toutes les faces
- Hauteur du socle H: $\leq 0,01$ mm

Lieferumfang:

- Bedienungsanleitung
- Incl. Spannschlüssel
- 4 Stück Spannpratzen

Delivery:

- Instructions for use
- Wrench
- 4 pcs. vice clamps

Livraison avec:

- Mode d'emploi
- Clé de serrage
- 4 Mors de serrage

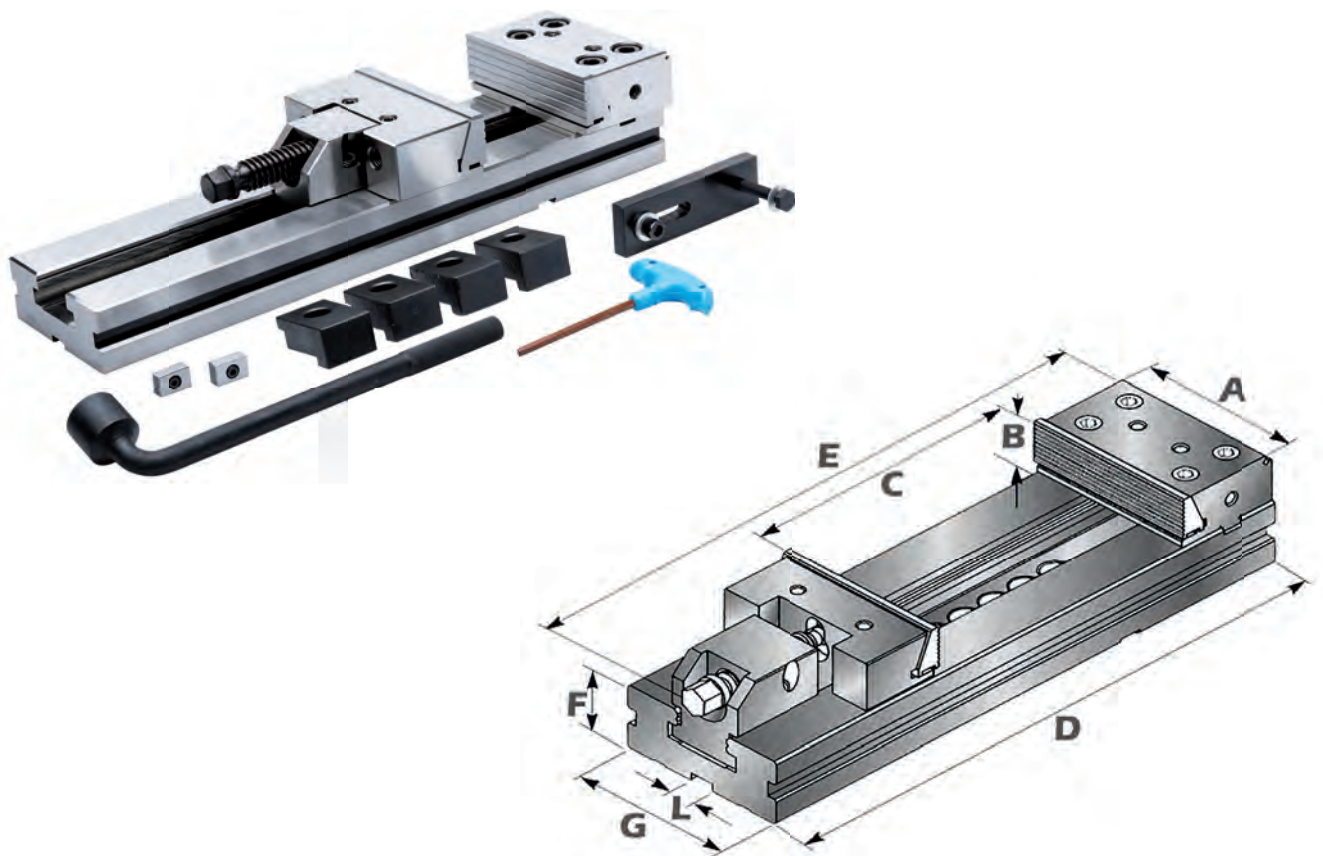

11

Bestell-Nr. Order no. Référence	Ausführung Version Type	A	B	C	D	E	F	G	L	kg
KS30125	ATI-125	125	40	150	345	410	40	95	16	13
KS30150	ATI-150	150	50	300	520	600	50	125	16	29
KS30175	ATI-175	175	60	300	555	630	58	145	16	42
KS30200	ATI-200	200	65	400	695	780	70	170	16	74



11.25

KEMMLER

2020

Drehplatte ATI
Swivel base ATI
Plateau tournant ATI



Bestell-Nr. Order no. / Référence	Ausführung Version / Type
Z.KS.30125	ATI-125
Z.KS.30150	ATI-150
Z.KS.30175	ATI-175
Z.KS.30200	ATI-200

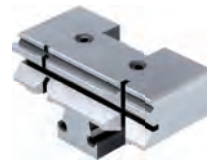

Prismenbacken
Prismatic jaws
Mors prismatiques

Bestell-Nr. Order no. / Référence	Ausführung Version / Type
Z.KS.PR.30125	ATI-125
Z.KS.PR.30150	ATI-150
Z.KS.PR.30175	ATI-175
Z.KS.PR.30200	ATI-200



Niederzugbacken
Hold down jaws
Mors d'emboutissage

Bestell-Nr. Order no. / Référence	Ausführung Version / Type
Z.KS.NZ.30125	ATI-125
Z.KS.NZ.30150	ATI-150
Z.KS.NZ.30175	ATI-175
Z.KS.NZ.30200	ATI-200



Ersatzbacken
Jaws
Mors d'échange

Bestell-Nr. Order no. / Référence	Ausführung Version / Type
Z.KS.SA.30125	ATI-125
Z.KS.SA.30150	ATI-150
Z.KS.SA.30175	ATI-175
Z.KS.SA.30200	ATI-200



Ersatzbacken ALT
Jaws ALT
Mors d'échange ALT

Bestell-Nr. Order no. / Référence	Ausführung Version / Type
Z.KS.ALT4401	ALT-100M/ALT-100L



Ersatzbacken ALT
Jaws ALT
Mors d'échange ALT

Bestell-Nr. Order no. / Référence	Ausführung Version / Type
Z.KS.ALT4402	ALT-100M/ALT-100L

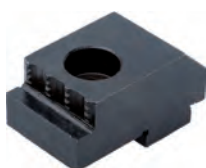

Ersatzbacken ALT
Jaws ALT
Mors d'échange ALT

Bestell-Nr. Order no. / Référence	Ausführung Version / Type
Z.KS.ALT4403	ALT-100M/ALT-100L



Ersatzbacken ALT
Jaws ALT
Mors d'échange ALT

Bestell-Nr. Order no. / Référence	Ausführung Version / Type
Z.KS.ALT4404	ALT-100M/ALT-100L



Schleif- und Kontrollschraubstöcke mit Gewindespindel

Grinding and inspection vices with threaded spindle
Etaux de contrôle et de rectification à réglage à vis

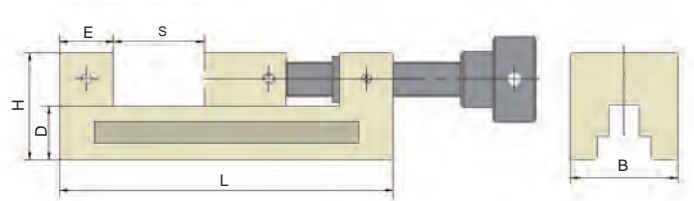
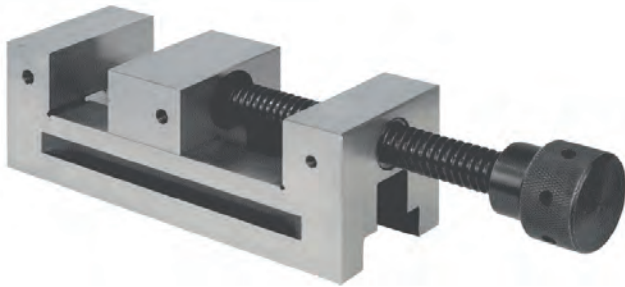

Bestell-Nr. Order no. Référence	B	H	E	D	S_{max}	L	kg
90.11.050	50	50	25	25	65	155	3
90.11.073	73	74	32	39	100	210	5
90.11.100	100	95	38	50	125	260	13

Schleif- und Kontrollschraubstöcke mit Schnellverstellung

Grinding and inspection vices with quick adjustment
Etaux de contrôle et de rectification à réglage rapide

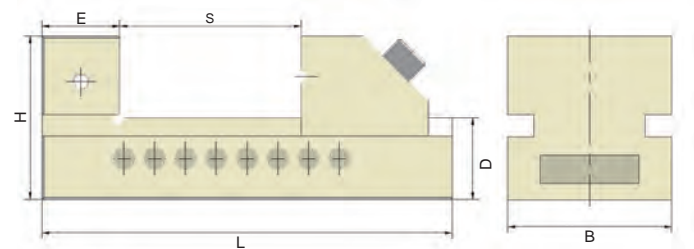

Bestell-Nr. Order no. Référence	B	H	E	D	S_{max}	L	kg
90.12.050	50	50	30	25	65	140	2
90.12.073	73	67	35	32	100	190	5
90.12.100	100	90	47	45	125	245	11

Universal, grinding and inspection vices
 Etaux de contrôle et de rectification universel

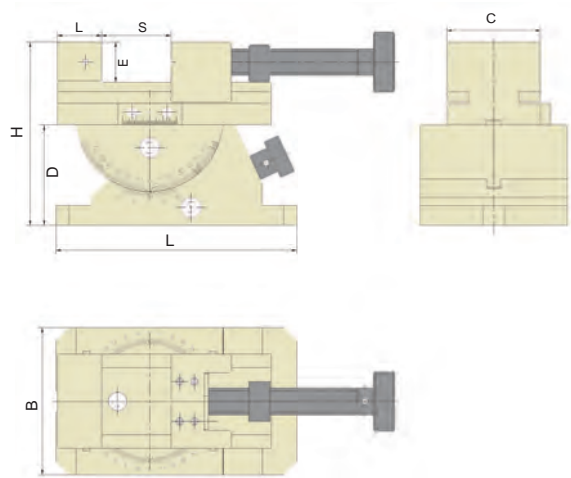
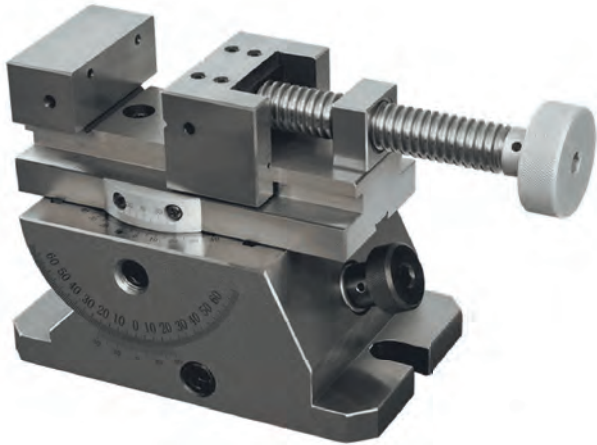

Bestell-Nr. Order no. Référence	B	H	D	E	C	S_{max}	L	kg
90.17.080	110	137	75	30	70	80	180	12

Bohrmaschinenschraubstöcke, mechanisch

Vices for drilling machines, mechanical
 Etaux pour foreuses, mécanique



Bestell-Nr. Order no. Référence	Ausführung Version Type	kg
KS4080	MWM-80	2,3
KS4100	MWM-100	2,9
KS4150	MWM-150	5,7
KS4200	MWM-200	11,5



Ersatzbacken-Paare

Pair of spare jaws
Paire de mors de rechange

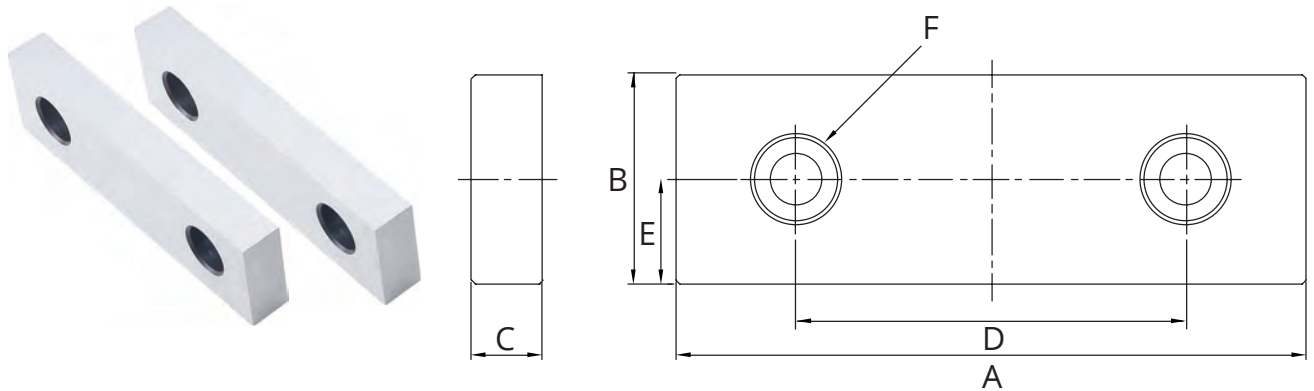

Bestell-Nr. Order no. Référence	Ausführung Version Type	A	B	C	D	E	F
Z.KS.SA.AT409	ATW-40 ATD-460	102	35	15	63,5	17,5	3/8 - 16 UNC
Z.KS.SA.AT509	ATW-50 ATD-570	126	38,1	17	79,4	20,6	7/16 - 14 UNC
Z.KS.SA.ATL609	ATW-675 ATW-689 MG-60 AMC-60 TLD-60	151	44,1	18	98,4	23,8	1/2 - 13 UNC
Z.KS.SA.ATL809	ATW-810	206	56	24,2	120	32	5/8 - 11 UNC
Z.KS.SA.AMC409	AMC-40	102	40	21	63,5	17,5	3/8 - 16 UNC
Z.KS.SA.AMP5401	AMP-150 [Paar/Innen Pair/inside Paire/interne]	128	52	15	90	25	M10 x 1,5 P
Z.KS.SA.AMP5402	AMP-150 [Außen Outside extérieur]	128	62	20	90	25	M10 x 1,5 P
Z.KS.SA.AMP5403	AMP-150 [Außen Outside extérieur]	128	62	20	90	25	M10 x 1,5 P
Z.KS.SA.AMP6401	AMP-160 AMP-165 [Paar/Innen Pair/inside Paire/interne]	158	55	15	90	25	M10 x 1,5 P
Z.KS.SA.AMP6402	AMP-160 AMP-165 [Außen Outside extérieur]	158	62	20	90	25	M10 x 1,5 P
Z.KS.SA.AMP6403	AMP-160 AMP-165 [Außen Outside extérieur]	158	62	20	90	25	M10 x 1,5 P
Z.KS.SA.AMP7401	AMP-180 [Paar/Innen Pair/inside Paire/interne]	178	60	20	120	28	M12 x 1,75 P
Z.KS.SA.AMP7402	AMP-180 [Außen Outside extérieur]	178	70	20	120	28	M12 x 1,75 P
Z.KS.SA.AMP7403	AMP-180 [Außen Outside extérieur]	178	70	20	120	28	M12 x 1,75 P
Z.KS.SA.AMP8401	AMP-200 AMP-300 [Paar/Innen Pair/inside Paire/interne]	200	60	18	120	28	M12 x 1,75 P
Z.KS.SA.AMP8402	AMP-200 AMP-300 [Außen Outside extérieur]	200	70	20	120	28	M12 x 1,75 P
Z.KS.SA.AMP8403	AMP-200 AMP-300 [Außen Outside extérieur]	200	70	20	120	28	M12 x 1,75 P

Pair of spare jaws
Paire de mors de rechange

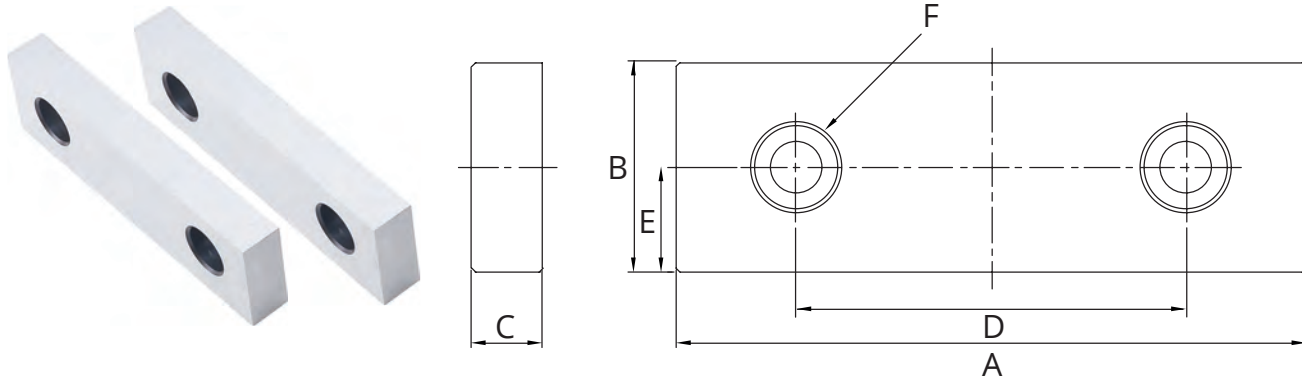

Bestell-Nr. Order no. Référence	Ausführung Version Type	A	B	C	D	E	F
Z.KS.SA.AVQ4401	AVQ-100 AVL-100	102	45	15	58	22,5	M8x 1,25 P
Z.KS.SA.AVQ5401	AVQ-125 AVL-125	124,7	53	15	60	26,5	M10 x 1,5 P
Z.KS.SA.AVQ6401	AVQ-160 AVL-160 ALQ-160	159,2	53	18	98,4	26,5	M12 x 1,75 P
Z.KS.SA.AVQ8401	AVQ-200 AVL-200 ALQ-200	199,5	58	18	120	29	M12 x 1,75 P
Z.KS.SA.HP403	HP-40	104	36	11	70	10	1/4 - 20 UNC
Z.KS.SA.HP503	HP-50 MP-50	130	46	15	85	16	5/16 - 18 UNC
Z.KS.SA.HP603	HP-60 MP-60	154	54	17	100	18	3/8 - 16 UNC
Z.KS.SA.HP803	HP-80 MP-80	206	62	21	120	24,5	M10 x 1,5 P
Z.KS.SA.AVC4401	AVC-100 AVM-100	100	48	15	60	22	M10 x 1,5 P
Z.KS.SA.AVC5401	AVC-130 AVM-130	130	55	15	90	25	M10 x 1,5 P
Z.KS.SA.AVC6401	AVC-160 AVM-160	160	58	15	90	25	M10 x 1,5 P
Z.KS.SA.AVC8401	AVC-200 AVM-200	200	63	18	120	28	M12 x 1,75 P
Z.KS.SA.TLD4401	TLD-40	102	38	15	63,5	17,5	3/8 - 16 UNC
Z.KS.ST.ALD6401	ALD-60	152	58	17	95	32	M12 x 1,75 P



Prismenbacken

Prismatic jaws
Mors prismatiques

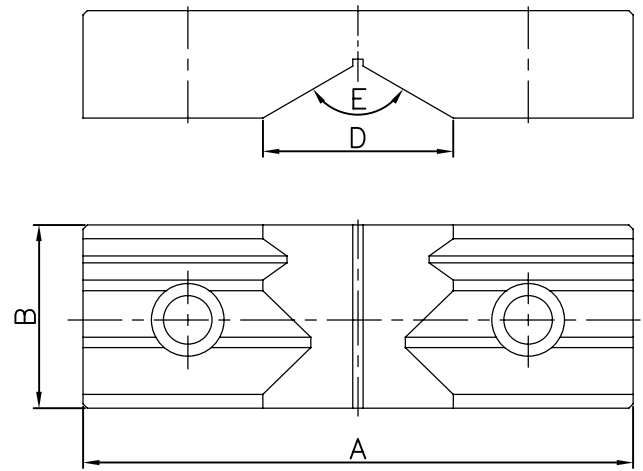
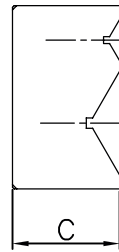

Bestell-Nr. Order no. Référence	Ausführung Version Type	A	B	C	D	E
Z.KS.PR.AT409R	ATW-40 ATD-460	102	35	31	40	120°
Z.KS.PR.AT509R	ATW-50 ATD-570	126	38,1	31	40	120°
Z.KS.PR.AT609R	ATW-675 689 MG-60 AMC-60 TLD-60	151	44,5	31	45	120°
Z.KS.PR.AT809R	ATW-810	206	60	36	60	120°
Z.KS.PR.AMC409R	AMC-40	102	40	30	40	120°
Z.KS.PR.AVQ4407	AVQ-100 AVL-100	102	45	28	36,3	120°
Z.KS.PR.AVQ5407	AVQ-125 AVL-125	124,7	53	31	50	120°
Z.KS.PR.AVQ6407	AVQ-160 AVL-160 ALQ-160	159,2	53	31	55	120°
Z.KS.PR.AVQ8407	AVQ-200 AVL-200 ALQ-200	200	56	31	55	120°
Z.KS.PR.HP403R	HP-40	104	36	31	40	120°
Z.KS.PR.HP503R	HP-50 MP-50	130	46	31	45	120°
Z.KS.PR.HP603R	HP-60 MP-60	154	54	31	55	120°
Z.KS.PR.HP803R	HP-80 MP-80	206	62	36	60	120°
Z.KS.PR.AVC6407	AVC-160 AVM-160	160	58	30	55	120°
Z.KS.PR.AVC8407	AVC-200 AVM-200	200	63	36	70	120°
Z.KS.PR.TLD4407	TLD-40	102	38	31	40	120°
Z.KS.PR.ALD6404	ALD-60	152	58	49	55	120°

Stufenbacken (Paar)



Step jaws (Pair)
Mors étagés (Paire)

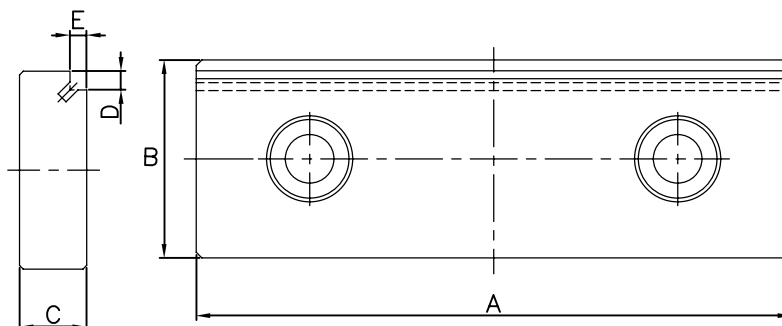

Bestell-Nr. Order no. Référence	Ausführung Version Type	A	B	C	D	E
Z.KS.ST.AT409L	ATW-40 ATD-460	102	35	15	4	3,5
Z.KS.ST.AT509L	ATW-50 ATD-570	126	38,1	17	4	3,5
Z.KS.ST.AT609L	ATW-675 ATW-689 MG-60 AMC-60 TLD-60	151	44,5	18	5	4,5
Z.KS.ST.AT809L	ATW-810	206	56	24,2	6	5,5
Z.KS.ST.AMC409L	AMC-40	102	40	21	4	3,5
Z.KS.ST.AVQ4404	AVQ-100 AVL-100	102	45	15	5	5
Z.KS.ST.AVQ5404	AVQ-125 AVL-125	124,7	53	15	5	5
Z.KS.ST.AVQ6404	AVQ-160 AVL-160 ALQ-160	159,2	53	18	5	4,5
Z.KS.ST.AVQ8404	AVQ-200 AVL-200 ALQ-200	200	56	18	4	5
Z.KS.ST.HP403L	HP-40	104	36	11	3,5	4
Z.KS.ST.HP503L	HP-50 MP-50	130	46	15	5	5
Z.KS.ST.HP603L	HP-60 MP-60	154	54	17	5	5
Z.KS.ST.HP803L	HP-80 MP-80	206	62	21	5,5	6
Z.KS.ST.AVC6404	AVC-160 AVM-160	160	58	15	5	5
Z.KS.ST.AVC8404	AVC-200 AVM-200	200	63	18	5	5
Z.KS.ST.TLD4402	TLD-40	102	38	15	8	5
Z.KS.ST.ALD6403	ALD-60	152	58	17	8	5



Geriffelte Backen / Rillenbacken (Paar)

Serrated jaws (Pair)
Mors à rainures (Paire)

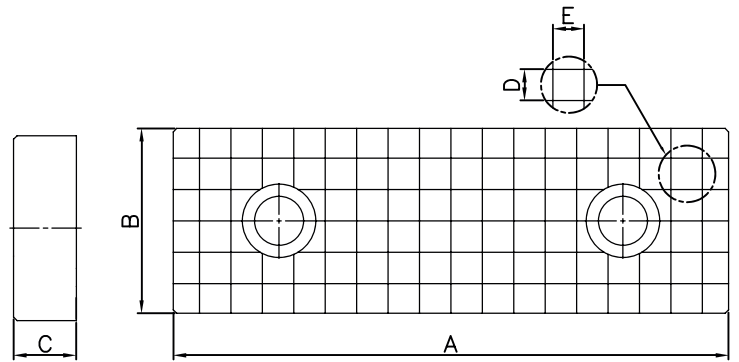
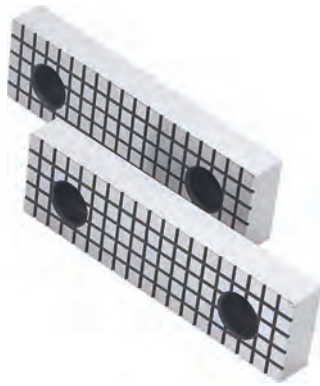

Bestell-Nr. Order no. Référence	Ausführung Version Type	A	B	C	D	E
Z.KS.GR.AT409T	ATW-40 ATD-460	102	35	15	9	9
Z.KS.GR.AT509T	ATW-50 ATD-570	126	38,1	17	9	9
Z.KS.GR.AT609T	ATW-675 ATW-689 MG-60 AMC-60 TLD-60	151	44,5	18	8	8
Z.KS.GR.AT809T	ATW-810	206	60	24,2	8	8
Z.KS.GR.AMC409T	AMC-40	102	40	21	9	9
Z.KS.GR.AVQ4405	AVQ-100 AVL-100	102	45	15	9	9
Z.KS.GR.AVQ5405	AVQ-125 AVL-125	124,7	53	15	9	9
Z.KS.GR.AVQ6405	AVQ-160 AVL-160 ALQ-160	159,2	53	18	9	9
Z.KS.GR.AVQ8405	AVQ-200 AVL-200 ALQ-200	200	56	18	9	9
Z.KS.GR.HP403T	HP-40 MP-40	104	36	11	8	8
Z.KS.GR.HP503T	HP-50 MP-50	130	46	15	8	8
Z.KS.GR.HP603T	HP-60 MP-60	154	54	17	8	8
Z.KS.GR.HP803T	HP-80 MP-80	206	100	30	8	8
Z.KS.GR.AVC6405	AVC AVM-160	160	58	15	8	8
Z.KS.GR.AVC8405	AVC AVM-200	200	63	18	8	8
Z.KS.GR.TLD4405	TLD-40	102	38	15	9	9
Z.KS.GR.ALD6405	ALD-60	152	58	49	25	25

Niederzugbacken (Paar)



Hold down jaws (Pair)
Mors d'emboutissage (Paire)

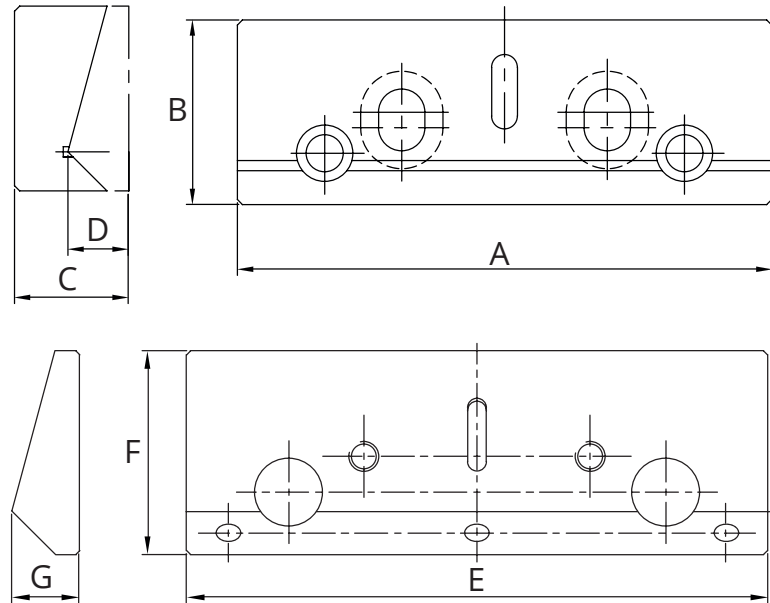

Bestell-Nr. Order no. Référence	Ausführung Version Type	A	B	C	D	E	F	G
Z.KS.NZ.HP403DA	HP-40	104	36	22,2	11,8	104	36	12
Z.KS.NZ.HP503DA	HP-50 MP-50	130	46	26,4	15,1	130	46	15,1
Z.KS.NZ.HP603DA	HP-60 MP-60	154	54	29,4	18	154	54	18
Z.KS.NZ.HP803DA	HP-80 MP-80	206	62	29,4	21	206	62	21



Werkstückanschlag ATW

Workpiece stop ATW
Dispositif de butée ATW



Bestell-Nr. Order no. Référence	Ausführung Version Type
Z.KS.ATW40ST	4" ATW-40 ATD-460
Z.KS.ATW50ST	5" ATW-50 ATD-570
Z.KS.ATW60ST	6" ATW-675 ATW-689
Z.KS.ATW80ST	8" ATW-810

Werkstückanschlag, universal

Workpiece stop, universal
Dispositif de butée, universel



Bestell-Nr. Order no. Référence	Ausführung Version Type
Z.KS.ATS160BH	ATS-160BH/T-16mm

Winkelprisma, einstellbar



Adjustable prism square
Équerre à prisme, ajustable



Bestell-Nr. Order no. Référence	Ausführung Version Type
GAP-25	75 x 25 x 36 x 25
GAP-30	102 x 30 x 49 x 30
GAP-46	102 x 46 x 49 x 30



T-Nuten (T-Nutensteine)

T-Nuts
Tasseaux

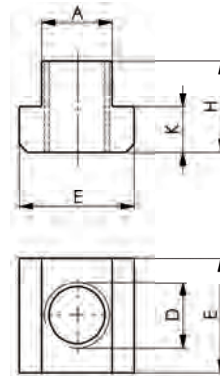

Bestell-Nr. Order no. Référence	Ausführung Version Type	A	D	E	H	K
Z.KS.80010	M6x8	7,7	M6	13	10	6
Z.KS.80028	M8x10	9,7	M8	15	12	6
Z.KS.80366	M10x12	11,7	M10	18	14	7
Z.KS.800234	M10x14		M10			
Z.KS.800366	M10x16	15,7	M10	25	18	9
Z.KS.81265	M10x18	17,7	M10	28	20	10
Z.KS.80051	M14x16		M14			
Z.KS.80176	M14x18	17,7	M14	28	20	10
Z.KS.80077	M18x20	19,7	M18	32	24	12
Z.KS.80242	M18x22	21,7	M18	35	28	14
Z.KS.80093	M22x24	23,7	M22	40	32	16

Scheiben DIN 6340

Plain washers DIN 6340
Joints DIN 6340

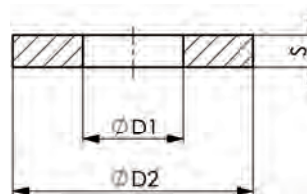
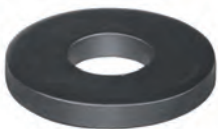

11

Bestell-Nr. Order no. Référence	Ausführung Version Type	D1	D2	S
Z.KS.82818	M6	6,4	17	2
Z.KS.82826	M8	8,4	23	4
Z.KS.82834	M10	10,5	28	4
Z.KS.82859	M14	15	40	5
Z.KS.82875	M18	19	45	6
Z.KS.82891	M22	23	50	8

Stiftschrauben DIN 6379



Studs DIN 6379
Boulon fileté DIN 6379

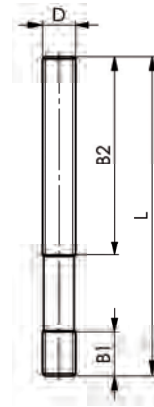

Bestell-Nr. Order no. Référence	Ausführung Version Type	B1	B2
Z.KS.84780	M6x50	9	30
Z.KS.81257	M8x40	11	20
Z.KS.81299	M10x50	13	25
Z.KS.84830	M10x80	13	50
Z.KS.81372	M14x63	17	32
Z.KS.84954	M18x125	23	75
Z.KS.86561	M18x160	23	100
Z.KS.81539	M22x160	31	100

Sechskantmuttern DIN 6330B

Fixture nuts DIN 6330B
Écrou hexagonal DIN 6330B

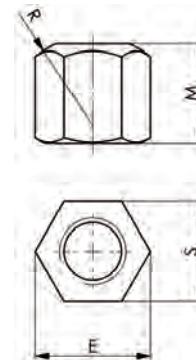

Bestell-Nr. Order no. Référence	Ausführung Version Type	E	M	R	S
Z.KS.82362	M6	11,05	9	9	10
Z.KS.82370	M8	14,40	12	12	13
Z.KS.82354	M10	17,80	15	15	16
Z.KS.82321	M14	23,40	21	20	21
Z.KS.82420	M18	30,10	27	24	27
Z.KS.82339	M22	37,70	33	30	34



Drehplatte

Swivel base
Plateau tournant

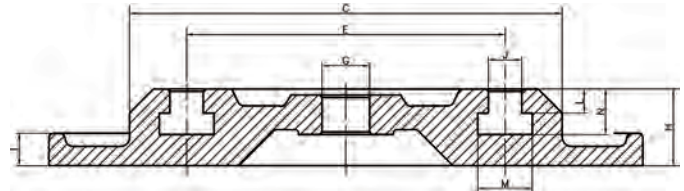
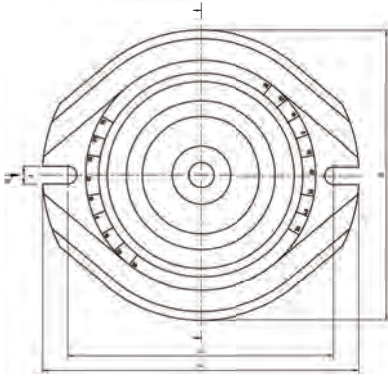

Bestell-Nr. Order no. Référence	Ausführung Version Type	A	B	C	D	E	F	G	H	I	J	K	L	M	N
Z.KS.HP402A	HP-40	233	220	167	197	125	12	16	25	25	11	0	7	19	15
Z.KS.HP502A	HP-50 / MP-50	272	260	212	239	160	18	16	33	33	14	0	10	26	22
Z.KS.HP602A	HP-60 / MP-60	327	322	255	286	201	20	16	37	37	18	0	12	32	23
Z.KS.HP802A	HP-80 / MP-80	410	410	305	370	240	20	16	46	46	18	0	15	36	27
Z.KS.AT413A	ATW-40 / ATD-460	250	230	182	210	134	14	20	32	13,5	14	0	10	23,5	19
Z.KS.AT513A	ATW-50 / ATD-570	275	257	212	239	163	14	20	36	13,5	14	0	10	23,5	19
Z.KS.AT613A	ATW-675 / ATW689	320	300	255	280	191	20	25	42	14,5	17,5	0	13	34	30
Z.KS.AT813A	ATW-810	400	380	320	356	250	20	30	49	20	17	0	15	32	33

Aufspannsätze

Clamping sets
Jeux de serrage



Bestell-Nr. Order no. Référence	Ausführung Version Type
Z.KS.ACK08	M8x1,25 - 10mm T-Nut
Z.KS.ACK10	M10x1,5 - 12mm T-Nut
Z.KS.ACK12A	M12x1,75 - 14mm T-Nut
Z.KS.ACK12B	M12x1,75 - 16mm T-Nut
Z.KS.ACK12C	M12x1,75 - 18mm T-Nut

Spannpratzensatz 4-teilig



Clamping sets 4-parts

Set de sabots de serrage 4 pieces



Bestell-Nr. Order no. Référence	Ausführung Version Type
Z.KS.AVQ690102	14mm T-Nut
Z.KS.AVQ690104	16mm T-Nut
Z.KS.AVQ690106	18mm T-Nut
Z.KS.AVQ690105	20mm T-Nut

Parallel-Unterlagen-Sätze

Set of parallel supports

Jeu de supports parallèles



Verwendung:

Parallelunterlagen finden vielseitige Verwendung als Hilfsmittel zum Spannen und Positionieren z.B. beim Schleifen, Fräsen, Erodieren, Messen und Anreissen.

Application:

Parallels are widely used for clamping and positioning, f.e. during grinding, milling, eroding, measuring and scribing.

Application:

Parallèles sont largement utilisés pour le serrage et le positionnement, p.e. pendant le meulage, fraisage, électroérosion, mesurage et traçage.

Bestell-Nr. Order no. Référence	Ausführung Version Type
91.12.150.1	14 x 2 - 150 x 10 x 14 (16,18,20,22,24,26,28,30,32,35,40,45,50)
91.12.150.2	14 x 2 - 150 x 8 x 14 (16,18,20,22,24,26,28,30,32,35,40,45,50)
91.12.200.3	14 x 2 - 200 x 10 x 14 (16,18,20,22,24,26,28,30,32,35,40,45,50)
91.13.100.1	9 x 2 - 100 x 4 x 10 (14,18,22,26,30,34,38,42)

Härte: HRC 55 - 62
Hardness: HRC 55 - 62
Dureté: HRC 55 - 62

Genauigkeit: 0,01mm
Accuracy: 0,01mm
Exactitude: 0,01mm

Parallelität: 0,005mm
Parallelism: 0,005mm
Parallélisme: 0,005mm

MESSTECHNIK
METROLOGY
MÉTROLOGIE

MESSTECHNIK

METROLOGY

MÉTROLOGIE

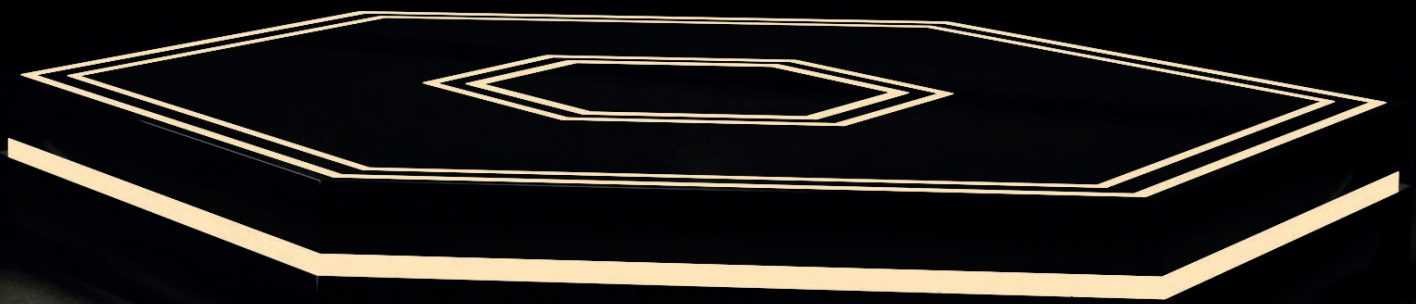
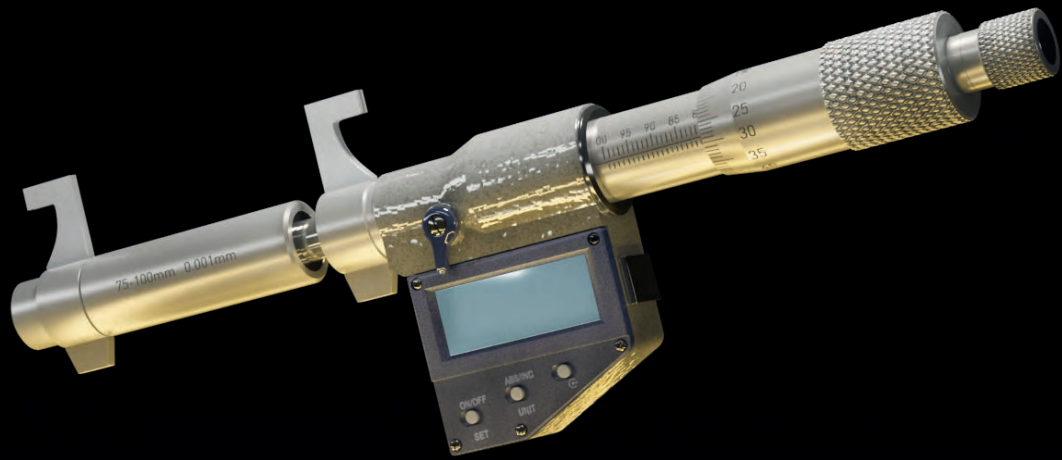



12.07	12.08	12.09	12.10
12.11	12.12	12.14	12.15
12.16	12.17	12.18	12.19
12.20	12.21	12.21	12.22
12.23	12.24	12.25	12.26
12.27	12.28	12.29	12.30
12.31	12.32	12.33	12.34

12.35	12.36	12.37	12.38
12.39	12.40	12.40	12.41
12.42	12.43	12.45	12.46
12.47	12.48	12.49	12.50
12.51	12.52	12.53	12.54
12.55	12.57	12.58	



Kemmler Kalibrierlabor

Unser Kalibrierlabor ist nach dem neuesten Stand der Technik ausgestattet und garantiert somit höchste Produktqualität.

Alle Werkzeuge werden nach unseren Design Spezifikationen hergestellt und mit der von uns entwickelten Kalibriersoftware nach den gültigen Normen

(z. B. ASME, DIN und JJG) geprüft.

Dadurch ist eine gleichbleibende Qualität und Messgenauigkeit der Messwerkzeuge gewährleistet .

Laboratorien, die eine Zertifizierung nach ISO 17025 nachweisen, stellen damit den hohen Qualitätsmaßstab unter Beweis, den das jeweilige Prüflabor auszeichnet.

Das zertifizierte Prüflabor hält damit alle erforderlichen Qualitäts-Standards zuverlässig ein und stellt die allgemeinen Anforderungen an die Kompetenz der Kalibrier- und Prüflaboratorien sicher.

Kemmler calibration lab

Our calibration lab meets the latest technical standard and, based on that, guarantees a high quality of products.

All our products are manufactured according to our design specifications and controlled based on our own calibration software corresponding to valid standards (e.g. ASME, DIN and JJG).

Thereby we ensure a constant quality and accuracy of our tools.

Laboratories working according to ISO/IEC 17025 give proof of the high quality standard, confirmed by the respective test laboratory. The accredited lab ensures that all quality standards are considered and guarantees that the high demands on calibrating and test laboratories are observed.

Kemmler labo de calibrage

Notre labo de calibrage est équipé de la technique à jour ce qui garantit une qualité très élevée. Tous nos porte-outils sont fabriqués selon nos spécifications de design et vérifiés par notre logiciel de calibrage selon les normes valables (p.ex. ASME, DIN et JJG).

Ainsi nous garantissons une qualité et précision de mesure constante.

Laboratoires certifiés selon ISO 17025 prouvent leur qualité élevée. En tant que labo certifié nous assurons que tous les standards de qualité indispensables sont respectés et que les exigences générales à un labo certifié sont observées.

Kal.-Zertifikat

Alle Messmittel mit diesem Button werden mit einem Kalibrierzertifikat nach DIN EN ISO 17025 ausgeliefert.

Kal.-Zertifikat

All measuring devices with this button will be supplied with a calibration certificate according to DIN EN ISO 17025.

Kal.-Zertifikat

Tous les instruments avec ce bouton seront fournis avec un certificate de calibrage selon DIN EN ISO 17025.



Calibration Certificate

Certificate No.	9E60001	Tool	IP67 Digital Calipers
Part Number	M.305.06.0	Range	(0~150)mm
Serial Number	1303659	Resolution	0.01mm
Standard Name	DIN862		

Visual Inspection Passed Function Inspection Passed

Outside Measurements

Reading	Nominal Value(mm)	Tolerance(mm) +/-	Deviation(mm)	Disposition*
1	0.00	0.02	0.00	√
2	41.30	0.02	0.00	√
3	81.50	0.02	-0.01	√
4	131.40	0.03	-0.01	√

Inside Measurements

Reading	Nominal Value(mm)	Tolerance(mm) +/-	Deviation(mm)	Disposition*
5	4.00	0.02	-0.01	√
6	25.00	0.02	-0.02	√

Depth Measurements

Reading	Nominal Value(mm)	Tolerance(mm) +/-	Deviation(mm)	Disposition*
7	0.00	0.02	0.01	√

Master information	Serial Number	DKD Number	Due Date
Gauge Block Set	0930	867,D-K-20153-01-00	2020/2/24

Humidity 50 % ± 15% Temperature 20 ± 0.5
 Uncertainty U=7.0µm +10⁻⁶×L coverage factor k=2

Calibrator

Approved By





Taschenmessschieber

Vernier calipers

Pieds à coulisse de poche

DIN 862-1988



Kal.-Zertifikat

mm / inch

INOX

Ausführung:

- Geeignet zum Messen von Außen-, Innendurchmessern, Tiefen und Längen
- Edelstahl mit gehärteten Messflächen

Construction:

- *Measuring surfaces allows measurement of external diameters, internal diameters, depths and steps*
- *Stainless steel with hardened measuring faces*

Type:

- Pour mesurer les diamètres extérieurs et intérieurs, profondeurs et longueurs
- Acier inoxydable avec surfaces de mesure trempée

Lieferumfang:

- Garantieschein
- Bedienungsanleitung
- Kalibrierzertifikat

Delivery:

- *Warranty card*
- *Instruction manual*
- *Calibration certificate*

Livraison avec:

- Certificat de garantie
- Mode d'emploi
- Certificat de calibrage

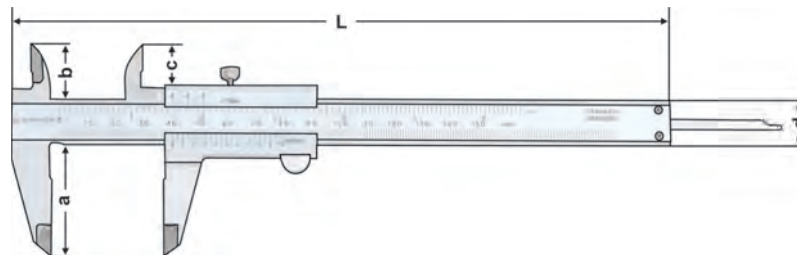

Bestell-Nr. Order no. Références	Messbereich Range Gamme de mesure	Skalenwert Scala Gamme	Genauigkeit Accuracy Précision	L	a	b	c	d
M.341.06.0	0 - 150	0,05 + 1/128"	± 0,05	235	40	21	16,5	16
M.341.08.0	0 - 200	0,05 + 1/128"	± 0,05	297	50	23,5	19	16
M.341.12.0	0 - 300	0,05 + 1/128"	± 0,05	410	64	27	22	20

Vernier calipers with thumb-lock
Pieds à coulisse de poche avec réglage du couple

DIN 862-1988



Kal.-Zertifikat

mm / inch

INOX

Ausführung:

- Geeignet zum Messen von Außen-, Innendurchmessern, Tiefen und Längen
- Edelstahl mit gehärteten Messflächen

Construction:

- *Measuring surfaces allow for the measurement of external diameters, internal diameters, depths and steps*
- *Stainless steel with surface hardened measuring faces*

Type:

- Pour mesurer les diamètres extérieurs et intérieurs, profondeurs et longueurs
- Acier inoxydable avec surfaces de mesure trempée

Lieferumfang:

- Garantieschein
- Bedienungsanleitung
- Kalibrierzertifikat

Delivery:

- *Warranty card*
- *Instruction manual*
- *Calibration certificate*

Livraison avec:

- Certificat de garantie
- Mode d'emploi
- Certificat de calibrage

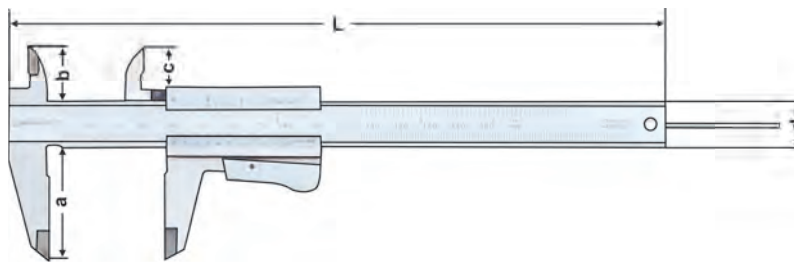

Bestell-Nr. Order no. Références	Messbereich Range Gamme de mesure	Skalenwert Scala Gamme	Genauigkeit Accuracy Précision	L	a	b	c	d
M.351.06.2*	0 - 150	0,05 + 1/128"	± 0,05	228	40	21	16,5	16
M.351.06.4	0 - 150	0,02 + 0,001"	± 0,02	228	40	21	16,5	16

*mit rundem Tiefenmaß Ø 1,8

*with with round depth bar Ø 1,8

*avec jauge de profondeur ronde Ø 1,8



Uhrenmessschieber

Dial vernier calipers

Pieds à coulisse à montre

DIN 862-1988



Kal.-Zertifikat

mm

INOX

Ausführung:

- Geeignet zum Messen von Außen-, Innendurchmessern, Tiefen und Längen
- Edelstahl mit gehärteten Messflächen
- Skalenteilung: 0.02mm

Construction:

- *Measuring surfaces allow for the measurement of external diameters, internal diameters, depths and steps*
- *Stainless steel with surface hardened measuring faces*
- *Graduation: 0.02mm*

Type:

- Pour mesurer les diamètres extérieurs et intérieurs, profondeurs et longueurs
- Acier inoxydable avec surface de mesure trempée
- Graduation: 0.02 mm

Lieferumfang:

- Garantieschein
- Bedienungsanleitung
- Kalibrierzertifikat

Delivery:

- *Warranty card*
- *Instruction manual*
- *Calibration certificate*

Livraison avec:

- Certificat de garantie
- Mode d'emploi
- Certificat de calibrage

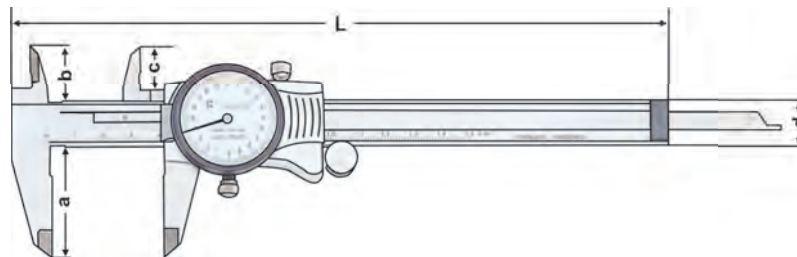
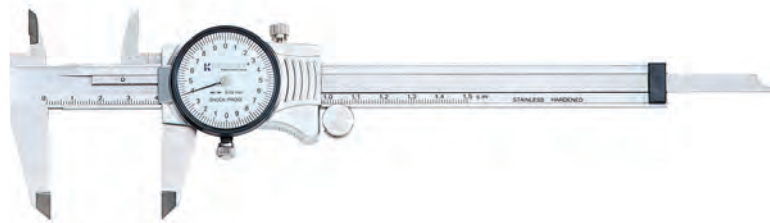

Bestell-Nr. Order no. Références	Messbereich Range Gamme de mesure	Skalenwert Scala Gamme	Genauigkeit Accuracy Précision	L	a	b	c	d
M.304.06.6	0 - 150	0,02	± 0,02	235	40	21	16,5	16

Workshop caliper with knife edge jaws and with fine adjustment

Pieds à coulisse d'atelier avec pointes de mesure et à vernier vissé

DIN 862-1988

Kal.-Zertifikat

mm / inch

INOX

Ausführung:

- Ablesung: 0.05mm / 1/128"
- Edelstahl
- mit Feineinstellung
- Die Messschnäbel sind abgerundet, um ein genaues Maß eines Innendurchmessers zu erhalten
- Messbereich 300 mm
Innendurchmesser ab 10 mm messbar
- Messbereich ab 500mm
Innendurchmesser ab 20 mm messbar

Construction:

- Graduation: 0.05mm / 1/128"
- Stainless steel
- With fine adjustment carriage to feed the slider finely
- Internal measurement jaws are rounded to provide accurate measurement of internal diameters
- Minimum internal diameter measurement capability of: 10mm for 300mm/12" range 20mm for over 500mm/20" range

Type:

- Graduation 0.05 mm/1/128"
- Acier inoxydable
- Avec réglage fin
- Pointes de bec arrondies pour avoir une mesure exacte du dia. intérieur
- Plage de mesure 300 mm, dia. intérieur mesurable dès 10 mm
- Plage de mesure 500 mm, dia. intérieur mesurable dès 20 mm

Lieferumfang:

- Garantieschein
- Bedienungsanleitung
- Kalibrierzertifikat

Delivery:

- Warranty card
- Instruction manual
- Calibration certificate

Livraison avec:

- Certificat de garantie
- Mode d'emploi
- Certificat de calibrage

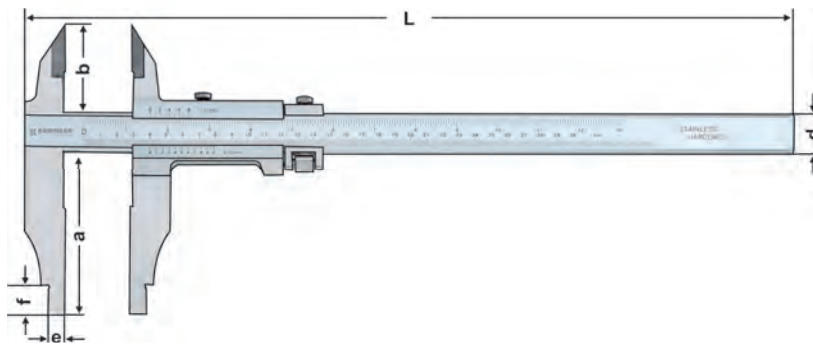
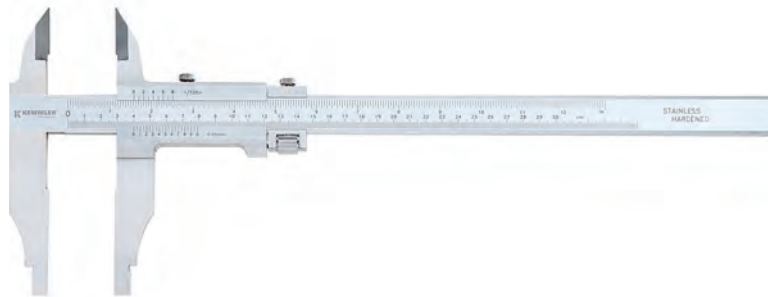

Bestell-Nr. Order no. Références	Messbereich Range Gamme de mesure	Skalenwert Scala Gamme	Genauigkeit Accuracy Précision	L	a	b	d	e	f
M.302.12.2	0 - 300	0,05 + 1/128"	± 0,08	470	100	56	25	10	18
M.302.20.2	0 - 500	0,05 + 1/128"	± 0,08	735	150	67	32	10	25
M.302.40.2	0 - 1000	0,05 + 1/128"	± 0,10	1035	150	67	32	10	25



Digital-Messschieber IP67

Digital pocket vernier calipers IP67

Pieds à coulisse à lecture numérique IP67

DIN 862-1988

IP 67



Kal.-Zertifikat

mm / inch

Ausführung:

- Auflösung: .0005" / 0.01mm
- IP 67
- extra großes LCD display
- Zoll/Metrisch
- Die Ausführung ermöglicht es den Messschieber unter rauen Werkstattbedingungen zu nutzen. Er ist wasser-, staub- und ölresistent.
- Schaltet sich automatisch ab

Lieferumfang:

- Garantieschein
- Bedienungsanleitung
- Kalibrierzertifikat
- CR2032 3,0V Batterie
- Schraubendreher

Construction:

- Resolution: .0005" / 0.01mm
- Conforms to the IP67 ratings
- Extra large LCD readout
- Inch/Metric conversion
- The design allows the caliper to be used in normal workshop conditions and is resistant to coolant, water, dust or oil
- Automatic switch off

Delivery:

- Warranty card
- Instruction manual
- Calibration certificate
- CR2032 3,0V Battery
- Screwdriver

Type:

- Résolution: .0005"/0.01 mm
- Conforme à IP67
- Affichage LCD extra large
- inch/métrique
- La construction permet l'utilisation dans l'atelier, résistant à eau, poussière et huile
- Arrêtage automatique

Livraison avec:

- Certificat de garantie
- Mode d'emploi
- Certificat de calibrage
- Pile CR2032 3,0V

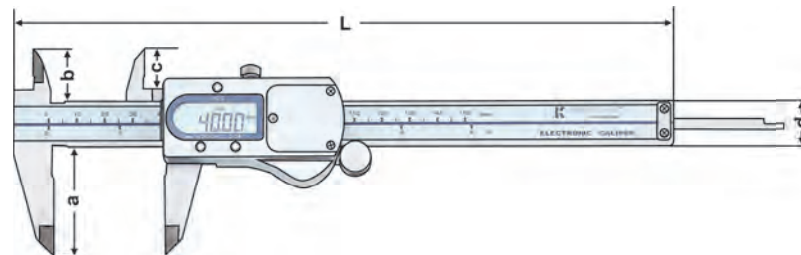
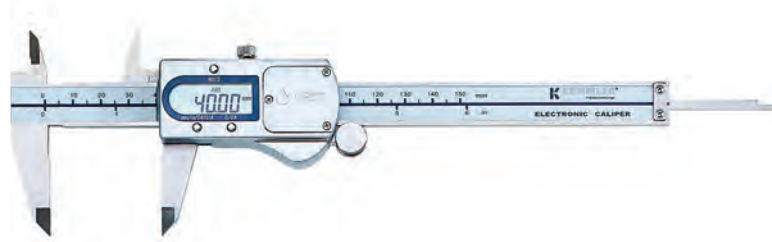

Bestell-Nr. Order no. Références	Messbereich Range Gamme de mesure	Skalenwert Scala Gamme	Genauigkeit Accuracy Précision	L	a	b	c	d
M.305.06.2	0 - 150	0,01	± 0,02	236	40	21	16,5	16
M.305.08.2	0 - 200	0,01	± 0,03	286	50	24	19,5	16
M.305.12.2	0 - 300	0,01	± 0,03	400	60	25	20,5	16



Digital pocket vernier calipers ABS

Pieds à coulisse à lecture numérique ABS

DIN 862-1988



Kal.-Zertifikat

mm / inch

Absolut-System

Ausführung:

- Auflösung: .0005" / 0.01mm
- Der Messschieber ist messbereit, sobald er eingeschaltet ist und die Anzeige im Display erscheint
- Es ist nicht nötig vor jedem Gebrauch den Messschieber wieder auf Null zu setzen, da die Stellung beibehalten wird, auch wenn der Messschieber ausgeschaltet ist
- Zoll/Metrisch
- Mit Datenausgang

Construction:

- Resolution: .0005" / 0.01mm
- The caliper will be ready for measurements as soon as it is switched on with the LCD screen displaying the actual slider position
- There is no need to set the zero position each time the caliper is used as the origin setting is retained even when the caliper is switched off
- Inch/Metric conversion
- Data output

Type:

- Résolution: .0005" / 0.01 mm
- Le pied à coulisse est prêt dès mise en marche et affichage sur l'écran
- Remise à zero n'est pas nécessaire avant chaque utilisation comme la position est gardée malgré désactivation
- Inch/métrique
- Avec sortie de données

Lieferumfang:

- Garantieschein
- Bedienungsanleitung
- Kalibrierzertifikat
- CR2032 3,0V Batterie

Delivery:

- Warranty card
- Instruction manual
- Calibration certificate
- CR2032 3,0V Battery

Livraison avec:

- Certificat de garantie
- Mode d'emploi
- Certificat de calibrage
- Pile CR2032 3,0V

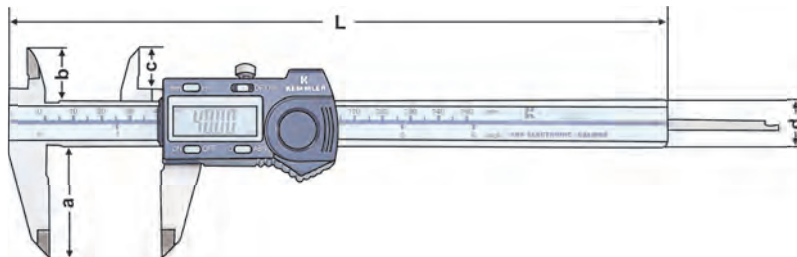

Bestell-Nr. Order no. Références	Messbereich Range Gamme de mesure	Skalenwert Scala Gamme	Genauigkeit Accuracy Précision	L	a	b	c	d
M.307.56.2	0 - 150	0,01	± 0,02	236	40	21	16,5	16
M.307.58.2	0 - 200	0,01	± 0,03	286	50	24	19,5	16
M.307.62.2	0 - 300	0,01	± 0,03	400	60	25	20,5	16

Zubehör | Accessories | Accessoires

Batterie 3 V | CR2032
Battery 3 V | CR2032
Pile 3 V | CR2032

M.CR2032

Datenverbindungskabel
Data Connection Cable
Câble de raccordement

M.900.05.4 | M.900.05.5 | M.901.00.3 | M.901.00.4



12.58

12.58

12.58



Digital-Messschieber

Digital pocket vernier calipers Pieds à coulisse à lecture numérique

DIN 862-1988



Kal.-Zertifikat

mm / inch

Ausführung:

- Auflösung: .0005" / 0.01mm
- Der Messschieber ist messbereit, sobald er eingeschaltet ist und die Anzeige im Display erscheint
- Es ist nicht nötig vor jedem Gebrauch den Messschieber wieder auf Null zu setzen, da die Stellung beibehalten wird, auch wenn der Messschieber ausgeschaltet ist
- Zoll/Metrisch

Lieferumfang:

- Garantieschein
- Bedienungsanleitung
- Kalibrierzertifikat
- CR2032 3,0V Batterie

Construction:

- Resolution: .0005" / 0.01mm
- The caliper will be ready for measurements as soon as it is switched on with the LCD screen displaying the actual slider position
- There is no need to set the zero position each time the caliper is used as the origin setting is retained even when the caliper is switched off
- Inch/Metric conversion

Delivery:

- Warranty card
- Instruction manual
- Calibration certificate
- CR2032 3,0V Battery

Type:

- Résolution: .0005" /0.01 mm
- Le pied à coulisse est prêt dès mise en marche et affichage sur l'écran
- Remise à zero n'est pas nécessaire avant chaque utilisation comme la position est gardée malgré désactivation
- inch/métrique

Livraison avec:

- Certificat de garantie
- Mode d'emploi
- Certificat de calibrage
- Pile CR2032 3,0V

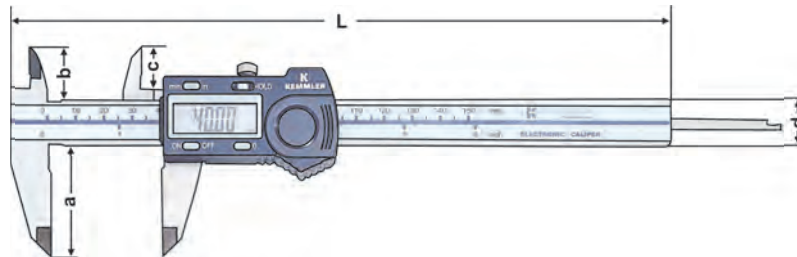

Bestell-Nr. Order no. Références	Messbereich Range Gamme de mesure	Skalenwert Scala Gamme	Genauigkeit Accuracy Précision	L	a	b	c	d
M.307.06.4	0 - 150	0,01	± 0,02	236	40	21	16,5	16
M.307.08.4	0 - 200	0,01	± 0,03	286	50	24	19,5	16
M.307.12.4	0 - 300	0,01	± 0,03	400	60	25	20,5	16



Digital caliper heavy duty ABS Pied à coulisse d'atelier numérique ABS

DIN 862-1988

Kal.-Zertifikat

mm / inch

Absolut-System

Ausführung:

- Auflösung: .0005" / 0.01mm
- Mit Feinverstellung um eine exaktes Bewegen des Schiebers zu ermöglichen
- Die Messschnäbel sind abgerundet, um ein genaues Maß eines Innendurchmessers zu erhalten
- Innendurchmesser ab 20 mm messbar
- Zoll/Metrisch
- Nullstellung in jeder Position

Construction:

- Resolution: .0005" / 0.01mm
- Designed with fine adjustment to allow precise movement of the slider
- Internal measurement jaws are rounded to provide accurate measurement of internal diameters
- Minimum internal diameter measurement capability of 20mm
- Inch/Metric conversion
- Zero setting at any position

Type:

- Résolution: .0005" / 0.01 mm
- Avec réglage fin permettant le mouvement exact du poussoir
- Pointes de bec arrondies pour avoir une mesure exacte du dia. intérieur
- Dia. intérieur mesurable dès 20 mm
- Inch/métrique
- Remise à zero à chaque position

Lieferumfang:

- Garantieschein
- Bedienungsanleitung
- Kalibrierzertifikat
- CR2032 3,0V Batterie

Delivery:

- Warranty card
- Instruction manual
- Calibration certificate
- CR2032 3,0V Battery

Livraison avec:

- Certificat de garantie
- Mode d'emploi
- Certificat de calibrage
- Pile CR2032 3,0V

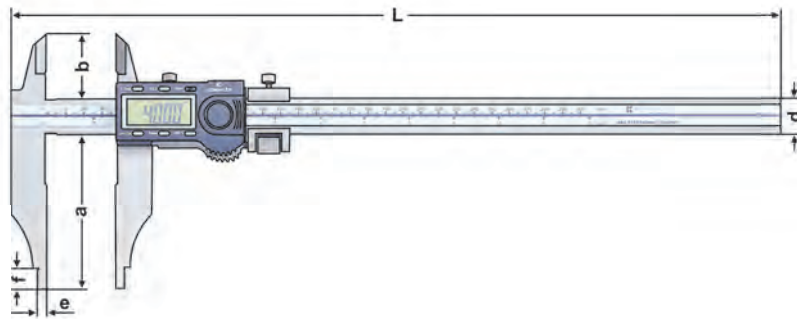

Bestell-Nr. Order no. Références	Messbereich Range Gamme de mesure	Skalenwert Scala Gamme	Genauigkeit Accuracy Précision	L	a	b	d	e	f
M.315.12.8	0 - 300	0,01	± 0,04	470	90	56	25	10	18
M.315.20.8	0 - 500	0,01	± 0,05	680	150	56	25	10	25
M.315.32.8	0 - 800	0,01	± 0,07	1030	150	67	32	10	25
M.315.40.8	0 - 1000	0,01	± 0,07	1230	150	67	32	10	25

Zubehör | Accessories | Accessoires

Batterie | Battery | Pile

M.CR2032

Datenverbindung | Data Connection | connexion de données

M.900.05.4 | M.900.05.5 | M.901.00.3 | M.901.00.4



K Digital Messschieber für Außennuten ABS

Digital vernier calipers for outside grooves ABS
 Pieds à coulisse numérique pour rainures extérieures ABS

- DIN 862-1988
- Kal.-Zertifikat
- mm / inch
- Absolut-System

Ausführung:

- Auflösung: .0005" / 0.01mm
- Misst Außennuten und Aussparungen
- Zoll/Metrisch
- Nullstellung bei jeder Position möglich

Construction:

- Resolution: .0005" / 0.01mm
- Measures external grooves and recessed hub dimensions
- Inch/Metric conversion
- Zero-setting at any position for incremental measurement

Type:

- Résolution: .0005" /0.01 mm
- Pour mesurer rainures extérieures et évidements
- inch/métrique
- Remise à zero possible à chaque position

Lieferumfang:

- Garantieschein
- Bedienungsanleitung
- Kalibrierzertifikat
- CR2032 3,0V Batterie

Delivery:

- Warranty card
- Instruction manual
- Calibration certificate
- CR2032 3,0V Battery

Livraison avec:

- Certificat de garantie
- Mode d'emploi
- Certificat de calibrage
- Pile CR2032 3,0V

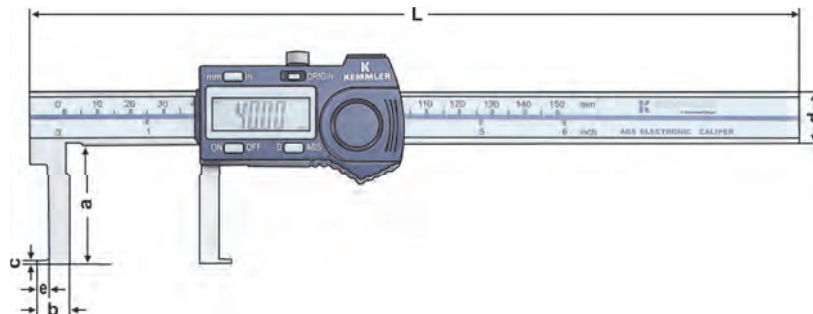

Bestell-Nr. Order no. Références	Messbereich Range Gamme de mesure	Skalenwert Scala Gamme	Genauigkeit Accuracy Précision	L	a	b	c	d	e
M.309.06.5	0 – 150	0,01	± 0,03	235	36	10	1	16	10
M.309.08.5	0 – 200	0,01	± 0,04	287	46	12,5	1,5	16	12,5
M.309.12.5	0 – 300	0,01	± 0,04	390	48	15	1,5	16	15

Zubehör | Accessories | Accessoires

- Batterie | Battery | Pile
M.CR2032
- Datenverbindung | Data Connection | connexion de données
M.900.05.4 | M.900.05.5 | M.901.00.3 | M.901.00.4



Digital vernier calipers for inside grooves ABS Pieds à coulisse numérique pour rainures intérieures ABS

DIN 862-1988

Kal.-Zertifikat

mm / inch

Absolut-System

Ausführung:

- Auflösung: .0005" / 0.01mm
- misst Innennuten, Bohrungen usw.
- Zoll/Metrisch
- Nullstellung bei jeder Position möglich

Construction:

- Resolution: .0005" / 0.01mm
- Measures internal grooves, bores and other details
- Inch/Metric conversion
- Zero-setting at any position for incremental measurement

Type:

- Résolution: .0005" / 0.01 mm
- Pour mesurer rainures intérieures, alésages etc.
- inch/métrique
- Remise à zero possible à chaque position

Lieferumfang:

- Garantieschein
- Bedienungsanleitung
- Kalibrierzertifikat
- CR2032 3,0V Batterie

Delivery:

- Warranty card
- Instruction manual
- Calibration certificate
- CR2032 3,0V Battery

Livraison avec:

- Certificat de garantie
- Mode d'emploi
- Certificat de calibrage
- Pile CR2032 3,0V

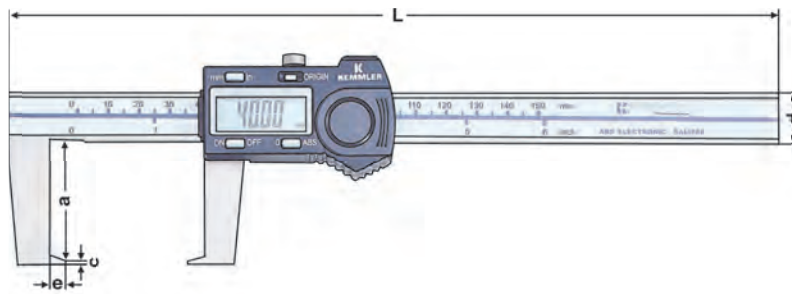

Bestell-Nr. Order no. Références	Messbereich Range Gamme de mesure	Skalenwert Scala Gamme	Genauigkeit Accuracy Précision	L	a	b	c	d	e
M.309.06.6	20 – 150	0,01	± 0,03	250	40	15	1	16	5
M.309.08.6	25 – 200	0,01	± 0,04	300	50	19	1,5	16	7
M.309.12.6	30 – 300	0,01	± 0,04	405	60	21	2	16	10

Zubehör | Accessories | Accessoires

Batterie | Battery | Pile
M.CR2032

Datenverbindung | Data Connection | connexion de données
M.900.05.4 | M.900.05.5 | M.901.00.3 | M.901.00.4



12.58

12.58

12.58



Tiefenmessschieber

Depth vernier calipers
Jauges de profondeur à lecture vernier

DIN 862-1988

Kal.-Zertifikat

mm

INOX

Ausführung:

- Auflösung: 0.05mm
- Messflächen sind feingeschliffen
- Gehärteter Edelstahl

Construction:

- Resolution: 0.05mm
- Measuring surfaces are precision ground for accuracy
- Stainless steel, hardened

Type:

- Resolution: 0.05 mm
- Surfaces de mesure rectifiées
- Acier inoxydable trempée

Lieferumfang:

- Garantieschein
- Bedienungsanleitung
- Kalibrierzertifikat

Delivery:

- Warranty card
- Instruction manual
- Calibration certificate

Livraison avec:

- Certificat de garantie
- Mode d'emploi
- Certificat de calibrage

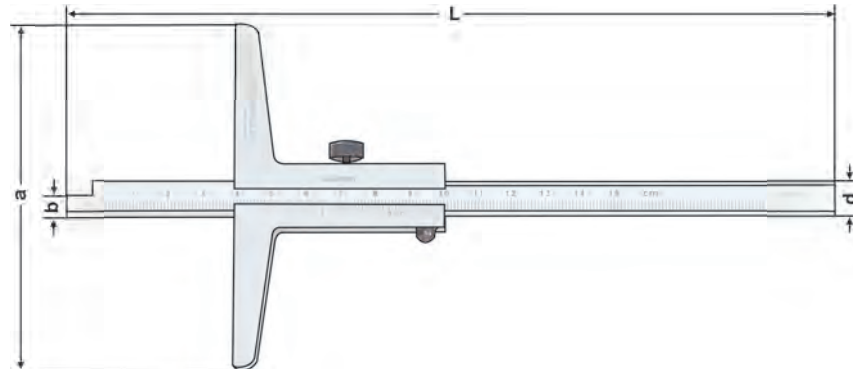
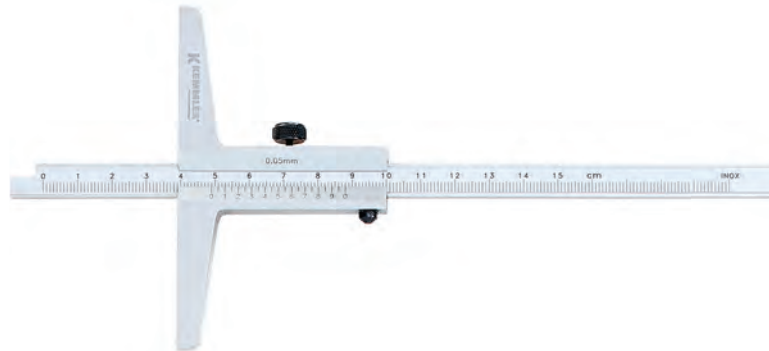

Bestell-Nr. Order no. Références	Messbereich Range Gamme de mesure	Skalenwert Scala Gamme	Genauigkeit Accuracy Précision	L	a	b	d
M.321.06.0	0 - 150	0,05	± 0,05	250	100	5	10
M.321.08.0	0 - 200	0,05	± 0,05	300	100	5	10
M.321.12.0	0 - 300	0,05	± 0,05	400	100	5	10

Digital depth vernier calipers ABS

Jauges de profondeur à lecture numérique ABS

DIN 862-1988

Kal.-Zertifikat

mm / inch

INOX

Ausführung:

- Auflösung: 0.01mm / .0005"
- Messflächen sind feingeschliffen
- Gehärteter Edelstahl

Construction:

- Resolution: 0.01mm / .0005"
- Measuring surfaces are precision ground for accuracy
- Stainless steel, hardened

Type:

- Resolution: 0.01 mm / .0005"
- Surfaces de mesure rectifiées
- Acier inoxydable trempée

Lieferumfang:

- Garantieschein
- Bedienungsanleitung
- Kalibrierzertifikat
- CR2032 3,0V Batterie

Delivery:

- Warranty card
- Instruction manual
- Calibration certificate
- CR2032 3,0V Battery

Livraison avec:

- Certificat de garantie
- Mode d'emploi
- Certificat de calibrage
- Pile CR2032 3,0V

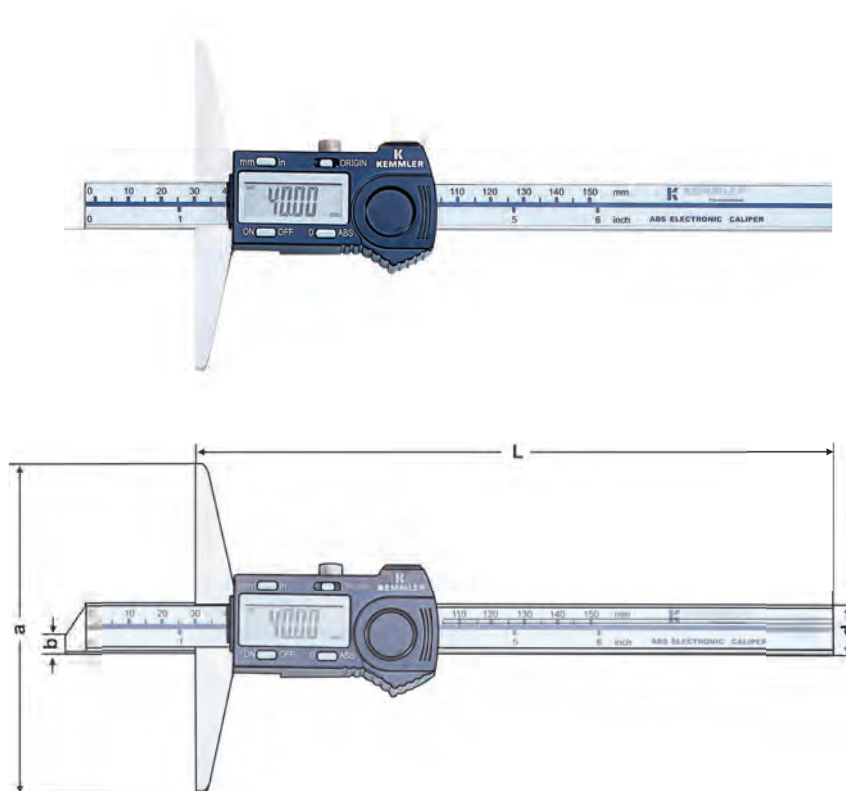

Bestell-Nr. Order no. Références	Messbereich Range Gamme de mesure	Skalenwert Scala Gamme	Genauigkeit Accuracy Précision	L	a	b	d
M.327.06.7	0 - 150	0,01	± 0,02	230	100	6	14,5
M.327.08.7	0 - 200	0,01	± 0,03	280	100	6	14,5
M.327.12.7	0 - 300	0,01	± 0,04	380	100	6	14,5

Zubehör | Accessories | Accessoires

Batterie | Battery | Pile

M.CR2032

Datenverbindung | Data Connection | connexion de données

M.900.05.4 | M.900.05.5 | M.901.00.3 | M.901.00.4



12.58

12.58

12.58



Digital-Tiefenmessschieber

Digital depth gauge

Jauges de profondeur à lecture numérique

DIN 862-1988

Kal.-Zertifikat

mm

Ausführung:

- Auflösung: .0005" / 0.01 mm
- die Originaleinstellung bleibt erhalten, solange die Batterie voll ist
- Zoll/Metrisch
- sphärischer Messeinsatz

Construction:

- Resolution: .0005" / 0.01 mm
- The origin point is retained throughout the life of the battery
- Inch/Metric conversion
- Spherical end anvil

Type:

- Resolution: .0005" / 0.01 mm
- Réglage original est gardé à moins que la pile soit pleine
- inch / métrique
- Embout de mesure sphérique

Lieferumfang:

- Garantieschein
- Bedienungsanleitung
- Kalibrierzertifikat
- LR44 1,5V Batterie

Delivery:

- Warranty card
- Instruction manual
- Calibration certificate
- LR44 1,5V Battery

Livraison avec:

- Certificat de garantie
- Mode d'emploi
- Certificat de calibrage
- Pile CR2032 3,0V

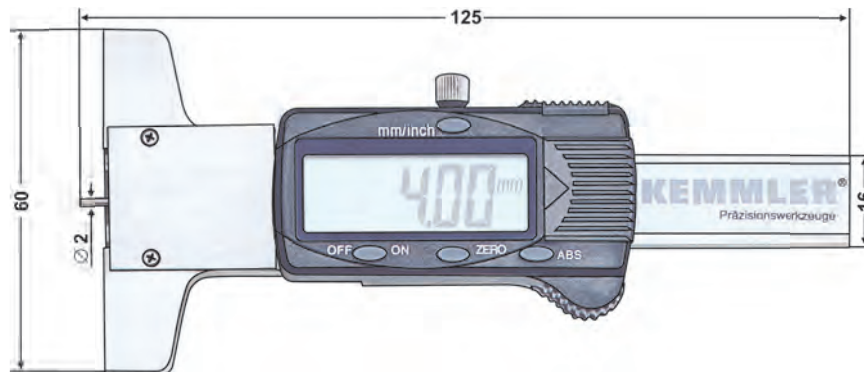

Bestell-Nr.
Order no.
Références

M.321.01.0

Messbereich
Range
Gamme de mesure

0 - 30

Skalenwert
Scala
Gamme

0,01

Genauigkeit
Accuracy
Précision

± 0,03



12.58

Kemmler Messmittelkoffer - 8 - teiliger Satz



Kemmler measuring equipment case - 8 - parts set
Kemmler coffre d'équipement de mesure set de - 8 - pièces



Bestell-Nr. Order no. Références	Abmessung Size Dimension
M.M.SET10	Bestehend aus: Consisting of: Contenu:
M.402.30.0	Präzisions Messuhr analog Dial indicator analogue Comparateur de précision analogique Ø 58 0,01 30 mm
M.402.10.0	Präzisions Messuhr analog Dial indicator analogue Comparateur de précision analogique Ø 58 0,01 10 mm
M.101.01.0	Bügelmessschraube analog Micrometer analogue Micromètre extérieur analogique 0 - 25 0,01 mm
M.105.01.4	Bügelmessschraube digital Micrometer digital Micromètre extérieur numérique 0 - 25 0,001
M.341.06.0	Messschieber analog Vernier caliper analogue Pied à coulisse analogique 0-150mm 1/128" 0,05mm
M.307.56.2	Digitaler Messschieber Digital Caliper Pied à coulisse numérique 0-150mm 0,01 mm
M.602.02.1	Präzisions Magnet Messstativ Precision Magnetic base Base magnétique de précision 350mm Ø 3/8" Ø8mm
M.501.08.2	Fühlhebelmessgerät Dial test indicator Indicateur à levier Ø 32 0,01 0,8mm



Bügelmessschrauben

External micrometer
Micromètres extérieurs

DIN 862-1988

Kal.-Zertifikat

mm

INOX

Ausführung:

- Ablesung: 0.001mm
- Ebenheit: 0.6my
- Hartmetallmessflächen
- Mit Ratsche

Construction:

- Graduation: 0.001mm
- Flatness: 0.6my
- Carbide tipped measuring faces
- Ratchet Stop

Type:

- Graduation: 0.001 mm
- Planéité: 0.6 my
- Surfaces de mesure en carbure monobloc
- Avec cliquet

Lieferumfang:

- Haken-Schlüssel, ab 25 mm Messbereich mit Einstellmaß
- Garantieschein
- Bedienungsanleitung
- Kalibrierzertifikat

Delivery:

- S-wrench, Standard (over 25mm range)
- Warranty card
- Instruction manual
- Calibration certificate

Livraison avec:

- Clé à ergot, plage de mesure dès 25 mm avec pignes de réglage
- Certificat de garantie
- Mode déplié
- Certificat de calibrage

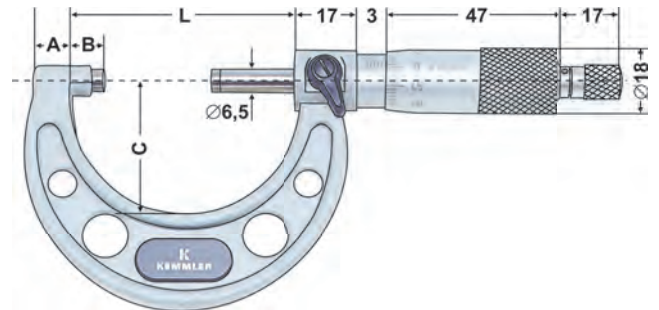

Bestell-Nr. Order no. Références	Messbereich Range Gamme de mesure	Skalenwert Scala Gamme	Genauigkeit Accuracy Précision	A	B	C	L
M.101.01.0	0 - 25	0,01	0,004	9	3	28	32
M.101.02.0	25 - 50	0,01	0,004	14	3	38	57
M.101.03.0	50 - 75	0,01	0,005	14,5	3	49	82
M.101.04.0	75 - 100	0,01	0,005	15	3	60	107
M.101.05.0	100 - 125	0,01	0,006	16,5	3	73	133
M.101.06.0	125 - 150	0,01	0,006	16,5	3	85	158
M.101.07.0	150 - 175	0,01	0,007	19,4	3	104	183
M.101.08.0	175 - 200	0,01	0,007	19,4	3	117	209
M.101.09.0	200 - 225	0,01	0,008	19,4	3	130	234
M.101.10.0	225 - 250	0,01	0,008	19,4	3	142	260
M.101.11.0	250 - 275	0,01	0,009	19,4	3	155	285
M.101.12.0	275 - 300	0,01	0,009	19,4	3	168	310



12

Bestell-Nr. Order no. Références	Messbereich Range Gamme de mesure	Skalenwert Scala Gamme	
M.101.64.8	0 - 100	0,01	Satz mit 4 St. Set with 4 pcs. Jeux avec 4 pc.
M.101.66.8	0 - 150	0,01	Satz mit 6 St. Set with 6 pcs. Jeux avec 6 pc.
M.101.72.8	0 - 300	0,01	Satz mit 12 St. Set with 12 pcs. Jeux avec 12 pc.

Prec. digital micrometers ABS IP65

Micromètres extérieurs numériques ABS IP65

DIN 863-1999

IP 65

Kal.-Zertifikat

mm / inch

INOX

Absolut-System

Ausführung:

- Auflösung: .00005"/0.001mm
- Anzeige: 0.01mm
- Ebenheit: 0.3µm
- Spritzwasserfest IP 65
- Umstellung Zoll/Metrisch
- Mit Ratsche
- Hartmetallmessflächen

Construction:

- Resolution: .00005"/0.001mm
- Scale: 0.01mm
- Flatness: 0.3µm
- Protection level IP65
- Inch/Metric conversion
- Ratchet Stop
- Carbide tipped measuring faces

Type:

- Resolution: .00005"/0.001 mm
- Affichage: 0.01 mm
- planéité: 0.3µm
- Résistant aux projections d'eau IP65
- inch / métrique
- Avec cliquet
- Surfaces de mesure en carbure monobloc

Lieferumfang:

- Haken-Schlüssel, ab 25 mm Messbereich mit Einstellmaß
- Garantieschein
- Bedienungsanleitung
- Kalibrierzertifikat
- CR2032 3,0V Batterie

Delivery:

- S-wrench, Standard (over 25mm range)
- Warranty card
- Instruction manual
- Calibration certificate
- CR2032 3,0V Battery

Livraison avec:

- Clé à ergot, plage de mesure dès 25 mm avec pignes de réglage
- Certificat de garantie
- Mode d'emploi
- Certificat de calibrage
- Pile CR2032 3,0V

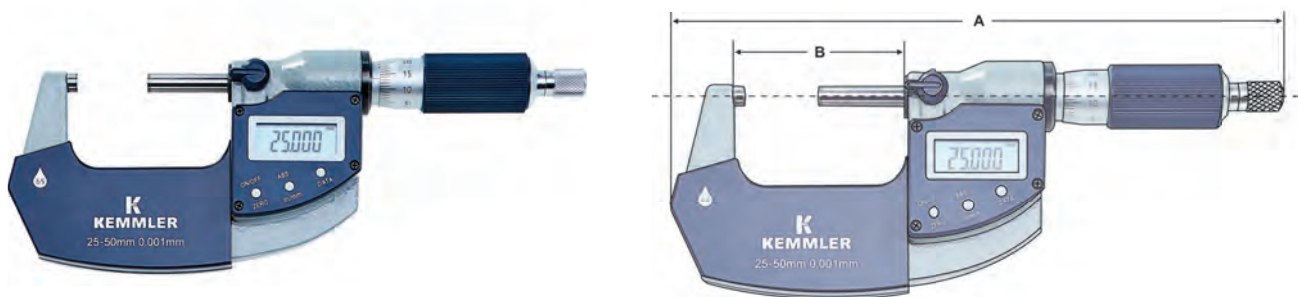

Bestell-Nr. Order no. Références	Messbereich Range Gamme de mesure	Skalenwert Scala Gamme	Genauigkeit Accuracy Précision	A	B
M.105.01.4	0 - 25	0,001	± 0,002	168	30
M.105.02.4	25 - 50	0,001	± 0,002	198	55
M.105.03.4	50 - 75	0,001	± 0,003	226	81
M.105.04.4	75 - 100	0,001	± 0,003	256	106
M.105.05.4	100 - 125	0,001	± 0,003	286	131
M.105.06.4	125 - 150	0,001	± 0,003	316	156

Zubehör | Accessories | Accessoires

Datenverbindungskabel | Data Connection Cable | Câble de raccordement

M.900.05.4 | M.900.05.5 | M.901.00.3 | M.901.00.4



12.58

12.58

12.58

K Innenmessschraube IP65 ABS

Inside micrometer IP65 ABS Micromètres d'intérieur IP65 ABS

DIN 863-1999

IP 65

Kal.-Zertifikat

mm / inch

INOX

Absolut-System

Ausführung:

- Auflösung: .00005" / 0.001 mm
- für das Messen von speziellen Innenmerkmalen
- Hartmetallmessflächen
- matt verchromt
- 5-30 mm und 25-50 mm werden mit Einstellringen geliefert
- Ratsche

Construction:

- Resolution: .00005" / 0.001mm
- Designed for the measurement of intricate internal characteristics
- carbide tipped measuring surfaces
- Satin chrome finished
- 5-30mm and 25-50mm range are supplied with setting rings
- Ratchet stop

Type:

- Resolution: .00005"/0.001 mm
- Pour mesurer caractéristiques spéciales intérieures
- Surfaces de mesure en carbure monobloc
- Chromé mat
- 5-30 mm et 25-50 mm sont livrés avec bagues de réglage
- Avec cliquet

Lieferumfang:

- Haken-Schlüssel
- Einstellringe
- Garantieschein
- Bedienungsanleitung
- Kalibrierzertifikat
- LR44 1,5V Batterie

Delivery:

- S-wrench
- Setting rings
- Warranty card
- Instruction manual
- Calibration certificate
- LR44 1,5V Battery

Livraison avec:

- Clé à ergot
- Baques de réglage
- Certificat de garantie
- Mode d'emploi
- Certificat de calibrage
- Pile LR44 1,5 V

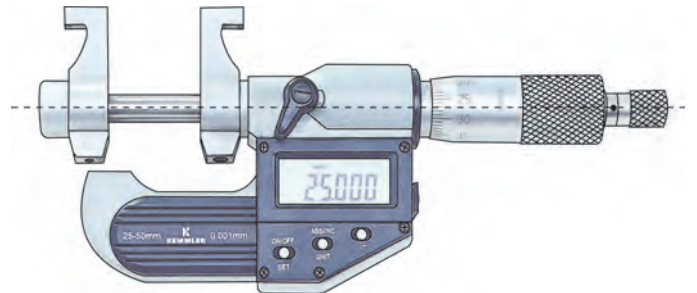

Bestell-Nr. Order no. Références	Messbereich Range Gamme de mesure	Skalenwert Scala Gamme	Genauigkeit Accuracy Précision
M.207.01.0	5 - 30	0,001	± 0,003
M.207.02.0	25 - 50	0,001	± 0,003
M.207.03.0	50 - 75	0,001	± 0,004
M.207.04.0	75 - 100	0,001	± 0,004
M.207.05.0	100 - 125	0,001	± 0,005
M.207.06.0	125 - 150	0,001	± 0,005
M.207.07.0	150 - 175	0,001	± 0,005
M.207.08.0	175 - 200	0,001	± 0,005

12

Zubehör | Accessories | Accessoires

Batterie | Battery | Pile
M.LR44

Datenverbindung | Data Connection | connexion de données
M.900.10.0



12.23

KEMMLER

2020

Blade Micrometer IP65 ABS

Micromètre extérieur pour mesure de rainures IP65 ABS

DIN 863-1999

IP 65

Kal.-Zertifikat

mm / inch

INOX

Absolut-System

Ausführung:

- Auflösung: .00005" / 0.001mm
- Für das Messen des Nutdurchmessers bei Wellen, Keilnuten usw.
- Automatisches AN/AUS für lange Lebensdauer der Batterie
- Meßergebnis sofort nach dem Einschalten ablesbar
- Umstellung Zoll/Metrisch
- Hartmetall Messflächen
- Nichtdrehende Spindel
- Ratsche

Lieferumfang:

- Haken-Schlüssel
- Ab 25 mm Messbereich mit Einstellmaß
- Garantieschein
- Bedienungsanleitung
- Kalibrierzertifikat
- LR44 1,5V Batterie

Construction:

- Resolution: .00005" / 0.001mm
- For measuring the groove diameter of shafts, keyways, and other hard to reach portions
- Automatic On/Off to maximize battery life
- Upon switching on the display will read the actual absolute measuring position
- Inch/Metric conversion
- Carbide tipped measuring faces
- Non-rotating spindle
- Ratchet stop

Delivery:

- S-wrench
- Standard (over 25mm range)
- Warranty card
- Instruction manual
- Calibration certificate
- LR44 1,5V Battery

Type:

- Resolution: .00005" / 0.001 mm
- Pour mesurer le dia. de rainure d'arbres, de rainures de clavette etc.
- Marche / arrêt automatique pour durée de vie accrue de la pile
- Résultat de mesure lisible dès mise en marche
- inch / métrique
- Surfaces de mesure en carbure monobloc
- Broche non-tournante
- Avec cliquet

Livraison avec:

- Clé à ergot
- Plage de mesure dès 25 mm avec pignes de réglage
- Certificat de garantie
- Mode d'emploi
- Certificat de calibrage
- pile LR44 1,5 V

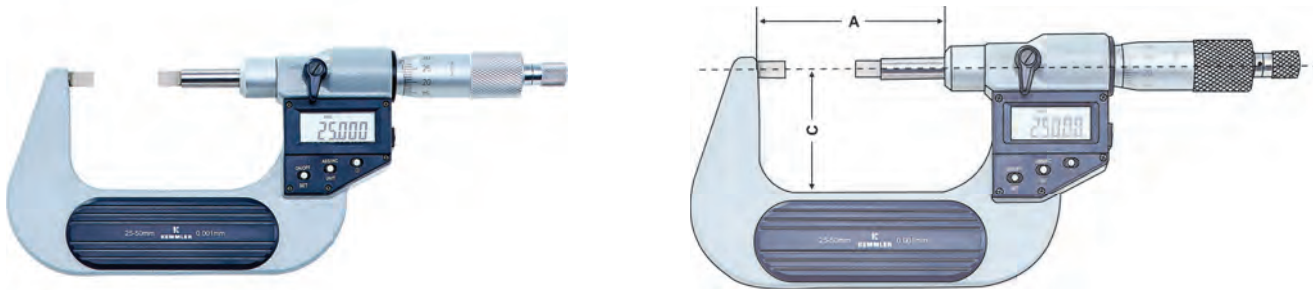

Bestell-Nr. Order no. Références	Messbereich Range Gamme de mesure	Skalenwert Scala Gamme	Genauigkeit Accuracy Précision	A	B
M.117.01.0	0 - 25	0,001	± 0,002	57	32
M.117.02.0	25 - 50	0,001	± 0,002	82	44,5
M.117.03.0	50 - 75	0,001	± 0,003	107	57
M.117.04.0	75 - 100	0,001	± 0,003	132,6	69,5

Zubehör | Accessories | Accessoires

Batterie | Battery | Pile

M.LR44

Datenverbindung | Data Connection | connexion de données

M.900.10.0





Halter für Bügelmessschrauben

Micrometer stand

Support pour micromètre

Ausführung:

- Halter für alle gängigen Bügelmessschrauben

Construction:

- *These stands are designed to allow bench top use with hand micrometers*

Type:

- Support pour tous micromètres standard



Bestell-Nr.
Order no.
Références

M.109.02.1

Material
Material
Matériel

Gusseisen | Cast iron | Fonte

2 +3 point internal micrometer | digital | IP65 | 3-12mm

Micromètre d'intérieur numérique à 2+3 touches | digital | IP65 | 3-12mm

DIN 863-4 IP 65 Kal.-Zertifikat mm Absolut-System

Ausführung:

- Ablesung: 0.001mm
- Geeignet für Sacklochbohrungen
- Hartmetallmessflächen
- Ableseteile mattverchromt
- Gefühlsratsche

Construction:

- Graduation: 0.001mm
- Measuring contact points are designed to allow measurements near to the bottom of blind holes
- reading parts brushed chromium-plated
- Measuring surfaces are carbide
- Ratchet stop

Type:

- Graduation: 0.001 mm
- Pour mesurer les alésages borgnes
- Surfaces de mesure en carbure monobloc
- Parties de lecture chromées mates
- Avec cliquet

Lieferumfang:

- Einstellringe
- Verlängerung > 6mm
- Garantieschein
- Bedienungsanleitung
- Kalibrierzertifikat
- LR44 1,5V Batterie

Delivery:

- Setting rings
- Extension rod >6mm
- Warranty card
- Instruction manual
- Calibration certificate
- LR44 1,5V Battery

Livraison avec:

- Bagues de réglage
- Rallonge >6mm
- Certificat de garantie
- Mode d'emploi
- Certificat de calibrage
- Pile LR44 1,5 V

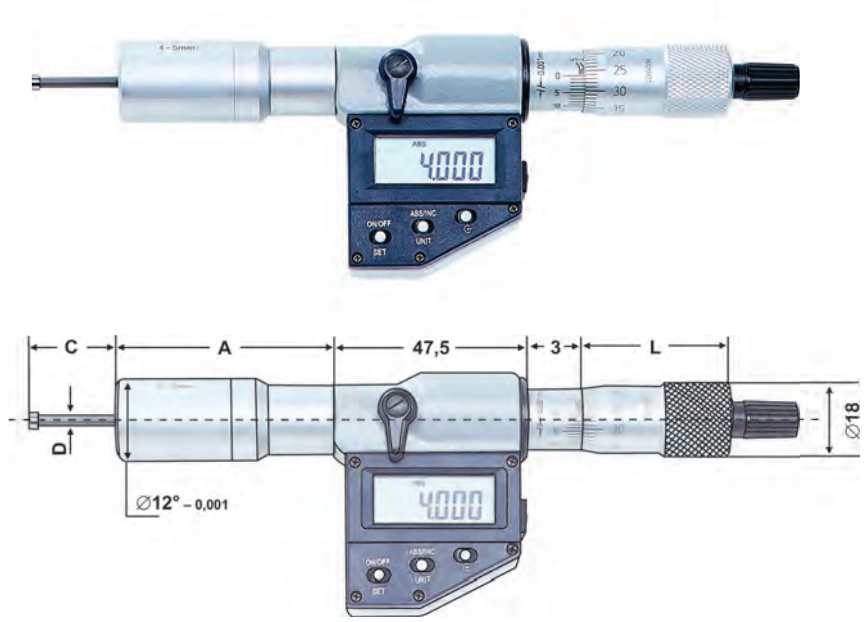

Bestell-Nr. Order no. Références	Messbereich Range Gamme de mesure	Skalenwert Scala Gamme	Genauigkeit Accuracy Précision	Einstellring Setting ring Bague de réglage	Verlängerung Extension rod Rallonge	L	A
M.208.08.0	3 - 4	0,001	0,004	4	-	22,5	-
M.208.09.0	4 - 5	0,001	0,004	5	-	22,5	-
M.208.10.0	5 - 6	0,001	0,004	6	-	22,5	-
M.208.11.0	6 - 8	0,001	0,004	6	100	53,5	100
M.208.12.0	8 - 9	0,001	0,004	8	100	53,5	100
M.208.13.0	10 - 12	0,001	0,004	10	100	53,5	100

Zubehör | Accessories | Accessoires

Batterie | Battery | Pile M.LR44 Datenverbindung | Data Connection | connexion de données M.900.10.0





3 Punkt Innenmessgerät | digital | IP65 | 12-100mm

3 point internal micrometer | digital | IP65 | 12-100mm

Micromètre d'intérieur numérique à 3 touches | digital | IP65 | 12-100mm

DIN 863-4

IP 65

Kal.-Zertifikat

mm / inch

Absolut-System

Ausführung:

- Ablesung: 0.001mm
- Geeignet für Sacklochbohrungen
- Hartmetallmessflächen
- Ableseteile mattverchromt
- Gefühlsratsche

Construction:

- Graduation: 0.001mm
- Measuring contact points are designed to allow measurements near to the bottom of blind holes
- Measuring surfaces are carbide
- reading parts brushed chromium-plated
- Ratchet stop

Type:

- Graduation: 0.001 mm
- Pour mesurer les alésages borgnes
- Surfaces de mesure en carbure monobloc
- Parties de lecture chromées mates
- Avec cliquet

Lieferumfang:

- Einstellringe
- Verlängerung
- Garantieschein
- Bedienungsanleitung
- Kalibrierzertifikat
- LR44 1,5V Batterie

Delivery:

- Setting rings
- Extension rod
- Warranty card
- Instruction manual
- Calibration certificate
- LR44 1,5V Battery

Livraison avec:

- Bagues de réglage
- Rallonge
- Certificat de garantie
- Mode d'emploi
- Certificat de calibrage
- Pile LR44 1,5 V

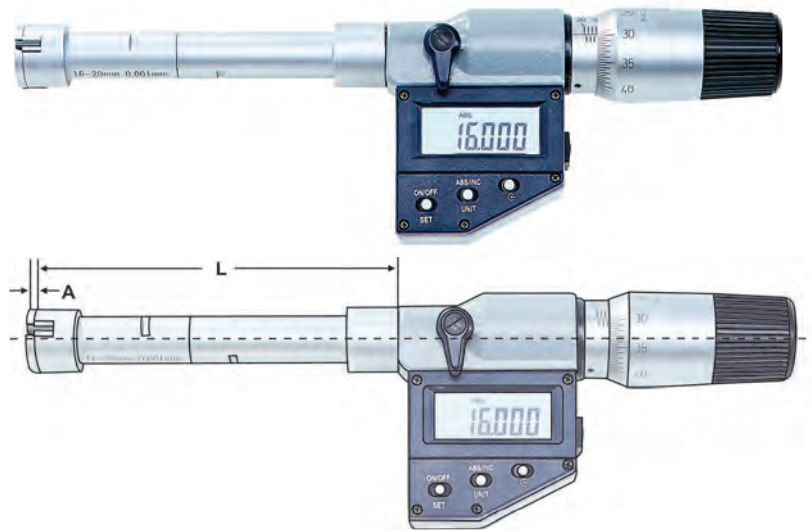

Bestell-Nr. Order no. Références	Messbereich Range Gamme de mesure	Skalenwert Scala Gamme	Genauigkeit Accuracy Précision	Einstellung Setting ring Bague de réglage	Verlängerung Extension rod Rallonge	L	A
M.208.24.0	12 - 16	0,001	0,004	16	150	80	0,5
M.208.25.0	16 - 20	0,001	0,004	16	150	80	0,5
M.208.26.0	20 - 25	0,001	0,004	25	150	90	0,5
M.208.27.0	25 - 30	0,001	0,004	25	150	90	0,5
M.208.28.0	30 - 40	0,001	0,004	40	150	97	0,5
M.208.29.0	40 - 50	0,001	0,005	40	150	97	0,5
M.208.30.0	50 - 63	0,001	0,005	62	150	114	0,5
M.208.31.0	62 - 75	0,001	0,005	62	150	114	0,5
M.208.32.0	75 - 88	0,001	0,005	87	150	114	0,5
M.208.33.0	87 - 100	0,001	0,005	87	150	114	0,5

Zubehör | Accessories | Accessoires

Batterie | Battery | Pile
M.LR44

Datenverbindung | Data Connection | connexion de données
M.900.10.0



3 point internal micrometer | digital | IP65 | 100-300mm

Micromètre d'intérieur numérique à 3 touches | digital | IP65 | 100-300mm

DIN 863-4

IP 65

Kal.-Zertifikat

mm / inch

Absolut-System

Ausführung:

- Ablesung: 0.001mm
- Geeignet für Sacklochbohrungen
- Hartmetallmessflächen
- Ableseteile mattverchromt
- Gefühlsratsche

Construction:

- Graduation: 0.001mm
- Measuring contact points are designed to allow measurements near to the bottom of blind holes
- Measuring surfaces are carbide
- reading parts brushed chromium-plated
- Ratchet stop

Type:

- Graduation: 0.001 mm
- Pour mesurer les alésages borgnes
- Surfaces de mesure en carbure monobloc
- Parties de lecture chromées mates
- Avec cliquet

Lieferumfang:

- Verlängerung
- Garantieschein
- Bedienungsanleitung
- Kalibrierzertifikat
- LR44 1,5V Batterie

Delivery:

- Extension
- Warranty card
- Instruction manual
- Calibration certificate
- LR44 1,5V Battery

Livraison avec:

- Rallonge
- Certificat de garantie
- Mode d'emploi
- Certificat de calibrage
- Pile LR44 1,5 V

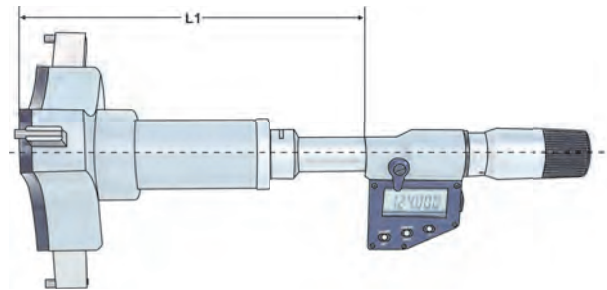

Bestell-Nr. Order no. Références	Messbereich Range Gamme de mesure	Skalenwert Scala Gamme	Genauigkeit Accuracy Précision	Einstellring* Setting ring* Bague de réglage*	Verlängerung Extension rod Rallonge	L1
M.208.34.0	100 - 125	0,001	0,005	112,5	150	145
M.208.35.0	125 - 150	0,001	0,005	137,5	150	145
M.208.36.0	150 - 175	0,001	0,005	162,5	150	145
M.208.37.0	175 - 200	0,001	0,005	187,5	150	145
M.208.38.0	200 - 225	0,001	0,007	212,5	150	145
M.208.39.0	225 - 250	0,001	0,007	237,5	150	145
M.208.40.0	250 - 275	0,001	0,007	262,5	150	145
M.208.41.0	275 - 300	0,001	0,007	287,5	150	145

*Einstellring nicht im Lieferumfang

*Setting ring not included in delivery

*bague de réglage non compris

Zubehör | Accessories | Accessoires

Batterie | Battery | Pile

M.LR44

Datenverbindung | Data Connection | connexion de données

M.900.10.0



12.58

12.58



DIN 878-2006

Kal.-Zertifikat

mm / inch

Absolut-System

Ausführung:

- Ablesung: 0.001mm
- Geeignet für Sacklochbohrungen
- Hartmetallmessflächen
- Ableseteile mattverchromt
- Gefühlsratsche

Lieferumfang:

- Einstellringe
- Verlängerung
- Garantieschein
- Bedienungsanleitung
- Kalibrierzertifikat
- CR2032 3,0V Batterie

Construction:

- Reading: 0.001mm
- Suitable for blind holes
- Carbide surfaces
- Reading parts dull chromed
- Ratchet stop

Delivery:

- Setting rings
- Extension rod
- Warranty card
- Instruction manual
- Calibration certificate
- CR2032 3,0V Battery

Type:

- Lecture: 0.001 mm
- Approprié pour trou borgne
- Surfaces de mesure en carbure
- Lectures chromé mat
- Avec cliquet

Livraison avec:

- Colliers de réglage
- Rallonge
- Certificat de garantie
- Mode d'emploi
- Certificat de calibrage
- CR2032 3,0V Pile

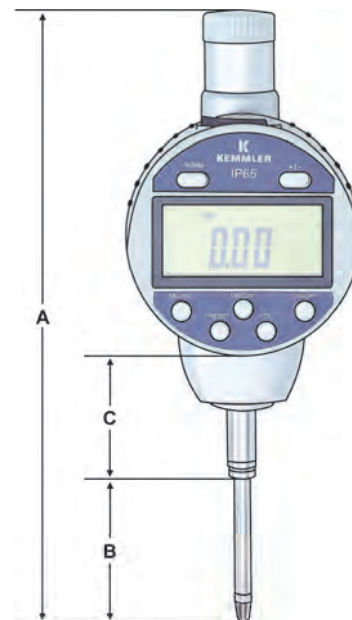

Bestell-Nr. Order no. Références	Messbereich Range Gamme de mesure	Skalenwert Scala Gamme	Genauigkeit Accuracy Précision	A	B	C
M.407.02.2	0 - 25	0,01	0,02	169	26,5	34,3
M.407.03.2	0 - 50	0,01	0,02	246	52	33,7
M.407.02.4	0 - 25	0,001	0,005	169	26,5	34,3
M.407.03.4	0 - 50	0,001	0,006	246	52	33,7

Zubehör | Accessories | Accessoires

Batterie | Battery | Pile
M.CR2032

Datenverbindung | Data Connection | connexion de données
M.900.07.0 | M.900.07.1 | M.901.00.3 | M.901.00.2



Dial indicator analogue Comparateur de précision analogique

DIN 878-2006

Kal.-Zertifikat

mm / inch

Ausführung:

- Skalenteilung: 0.01mm; 0.001mm
- Gehäusedurchmesser: Ø 58 mm
- Metallgehäuse mit drehbarem Ziffernblatt
- Leicht zu lesendes Ziffernblatt
- Steingelagert
- Schaft Durchmesser: Ø 8mm h6

Construction:

- Graduation: 0.01mm; 0.001mm
- Dial face dia.: Ø58mm
- Metal housing with rotating lever gauge
- Easy to read dial face
- Jeweled
- Stem diameter: Ø 8mm h6

Type:

- Graduation: 0.01mm; 0.001 mm
- Diamètre du boîtier: Ø58mm
- Boîtier métallique avec disque gradué orientable
- Cadran gradué, lecture facile
- Monté sur rubis
- Diamètre du queue: Ø 8mm h6

Lieferumfang:

- Garantieschein
- Bedienungsanleitung
- Kalibrierzertifikat

Delivery:

- Warranty card
- Instruction manual
- Calibration certificate

Livraison avec:

- Certificat de garantie
- Mode d'emploi
- Certificat de calibrage

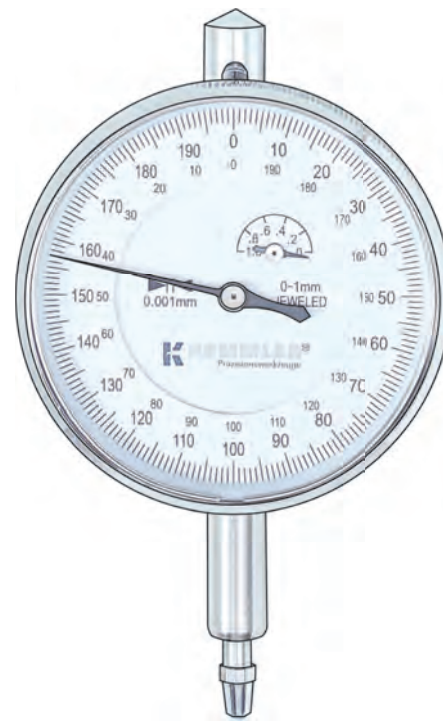
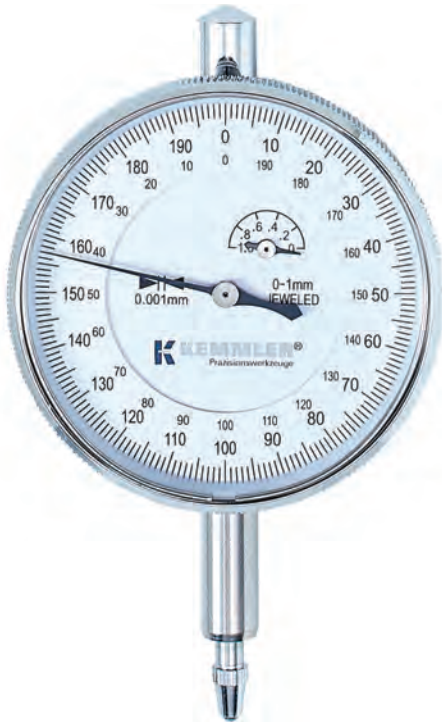

Bestell-Nr. Order no. Références	Messbereich Range Gamme de mesure	Skalenswert Scala Gamme	Ablesung Dial reading Lecture	Genauigkeit Accuracy Précision	Außenring Ø Outer ring Ø Bague extérieure Ø
M.402.01.0	1	0,001	0 - 200	0,005	58
M.402.03.0	3	0,01	0 - 100	0,010	58
M.402.05.0	5	0,01	0 - 100	0,012	58
M.402.10.0	10	0,01	0 - 100	0,015	58
M.402.25.0	25	0,01	0 - 50 - 0	0,035	58
M.402.30.0	30	0,01	0 - 100	0,035	58



Präzisions Messuhr analog

Dial indicator precision analogue
Comparateur de précision analogique

DIN 878-2006

Kal.-Zertifikat

mm

Ausführung:

- Auflösung: 0.001mm
- hohe Genauigkeit
- steingelagert und stoßfest
- wasser- und staubgeschütztes Design
- Schaftdurchmesser: 8mm

Construction:

- Resolution: 0.001mm
- High accuracy
- Jeweled and shock proof
- Water and dust resistant design
- With 8mm stem diameter

Type:

- Résolution: 0.001 mm
- Haute précision
- Monté sur rubis et résistant au choc
- Pour protéger contre les projections d'eau et la poussière
- Diamètre du queue 8 mm

Lieferumfang:

- Garantieschein
- Bedienungsanleitung
- Kalibrierzertifikat

Delivery:

- Warranty card
- Instruction manual
- Calibration certificate

Livraison avec:

- Certificat de garantie
- Mode d'emploi
- Certificat de calibrage

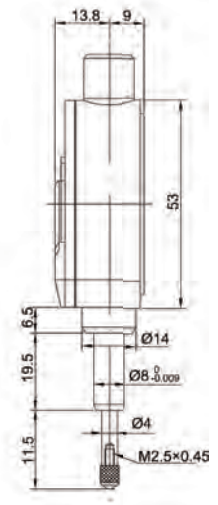
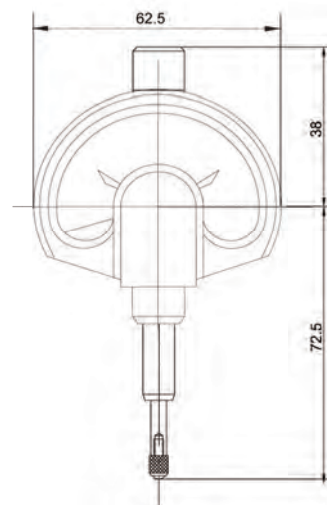

Bestell-Nr. Order no. Références	Messbereich Range Gamme de mesure	Skalenwert Scala Gamme	Ablesung Dial reading Lecture	Genauigkeit Accuracy Précision	Außenring Ø Outer ring Ø Bague extérieure Ø
M.422.21.2	0,05	0,001	50 - 0 - 50	0,0012	62

Dial test indicator Indicateur à levier

DIN 2270-
1985

Kal.-Zertifikat

mm

Ausführung:

- Skaleneinteilung: 0.002 mm oder 0.01 mm
- Steingelagert
- 8mm Schwalbenschwanzaufnahme
- Leicht zu lesendes Ziffernblatt
- 2mm Kontaktspitze aus Hartmetall
- Durchmesser von 32 mm oder 40 mm Gehäuse wählbar

Construction:

- Graduation: 0.002mm or 0.01mm
- Jeweled bearings
- With Ø8mm dovetail stems
- Easy to read face
- Ø2mm Carbide tipped contact point
- Ø32mm and Ø40mm dial face are optional

Type:

- Graduation: 0.002 mm ou 0.01 mm
- Monté sur rubis
- Logement queue d'aronde 8 mm
- Cadran gradué, lecture facile
- Pointe de contact 2 mm en carbure monobloc
- Diamètre du boîtier Ø32 mm ou Ø40 mm sélectionnable

Lieferumfang:

- Einspannschaft, Schlüssel
- Garantieschein
- Bedienungsanleitung
- Kalibrierzertifikat

Delivery:

- Stem, Wrench
- Warranty card
- Instruction manual
- Calibration certificate

Livraison avec:

- Queue de serrage, clé
- Certificat de garantie
- Mode d'emploi
- Certificat de calibrage

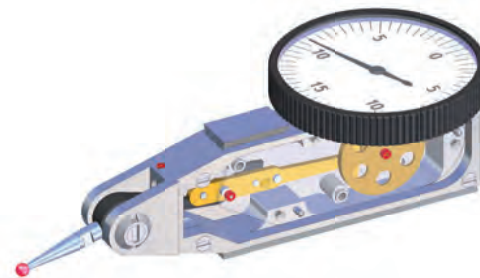

Bestell-Nr. Order no. Références	Messbereich Range Gamme de mesure	Skalenwert Scala Gamme	Ablesung Dial reading Lecture	Genauigkeit Accuracy Précision	Außenring Ø Outer ring Ø Bague extérieure Ø
M.501.02.2	0,2	0,002	0 - 100 - 0	0,004	32
M.501.08.2	0,8	0,01	0 - 40 - 0	0,013	32
M.502.02.2	0,2	0,002	0 - 100 - 0	0,004	40
M.502.08.2	0,8	0,01	0 - 40 - 0	0,013	40



Magnet-Messstativ mit Feineinstellung

Magnetic base with fine adjustment
Support magnétique avec réglage fin

Ausführung:

- Halterungsmechanismus für Fühlhebelmessgeräte und Messuhren 3/8" und 8 mm Einspannschaft
- Der Magnet wird durch einen Drehschalter an oder aus geschaltet
- Prismatische Sohle
- mit Feineinstellung
- 80kg Haltekraft

Construction:

- *holding device for test indicators and dial gauges 3/8" and 8 mm stem*
- *The magnet is switched on or off by a rotary knob*
- *prismatic base*
- *With Fine Adjustment*
- *80kg holding force*

Type:

- Mécanisme de fixation pour indicateurs à levier et comparateurs queue de serrage 3/8" et 8 mm
- Marche / arrêt de l'aimant par interrupteur
- Semelle prismatique
- Avec réglage fin
- Force de maintien 80 kg

Lieferumfang:

- Garantieschein
- Bedienungsanleitung

Delivery:

- *Warranty card*
- *Instruction manual*

Livraison avec:

- Certificat de garantie
- Mode d'emploi

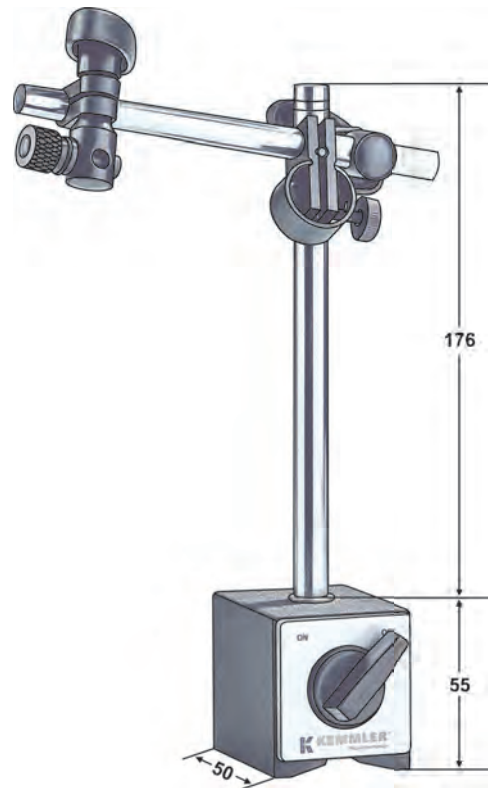

12

Bestell-Nr. Order no. Références	Haftkraft Prisma Adhesive force prism Force d'adhérence prisme	Prisma Prism Prisme	Aufnahmebohrung Mounting hole Alésage de logement	Säulen Column colonne	Querarm Cross arm bras trans.
M.601.02.0	80kg	60x50x55 (LxWxH)	Ø 3/8" + 8 mm	Ø 12 x 176	Ø 10 x 150

Magnetic base with flexible arm Base magnétique flexible

Ausführung:

- Halterungsmechanismus für Fühlhebelmessgeräte und Messuhren 8 mm Einspannschaft
- Der Magnet wird durch einen Drehschalter an oder aus geschaltet
- Prismatische Sohle
- 60kg Haltekraft

Construction:

- holding device for test indicators and dial gauges 8 mm stem
- The magnet is switched on or off by a rotary knob
- prismatic base
- With Fine Adjustment
- 60kg holding force

Type:

- Mécanisme de fixation pour indicateurs à levier et comparateurs queue de serrage 8 mm
- Marche / arrêt de l'aimant par interrupteur
- Semelle prismatique
- Force de maintien 60 kg

Lieferumfang:

- Garantieschein
- Bedienungsanleitung

Delivery:

- Warranty card
- Instruction manual

Livraison avec:

- Certificat de garantie
- Mode d'emploi



Bestell-Nr. Order no. Références	Haftkraft Prisma Adhesive force prism Force d'adhérence prisme	Gesamthöhe Total height Hauteur totale	Prisma Prism Prisme	Aufnahmebohrung Mounting hole Alésage de logement
M.601.11.0	80kg	360	60x50x55 (LxWxH)	8 mm



Präzisions Magnet Messstativ

Precision Magnetic base
Base magnétique de précision

Ausführung:

- Halterungsmechanismus für Fühlhebelmessgeräte und Messuhren 3/8" und 8 mm Einspannschaft
- Der Magnet wird durch einen Drehschalter an oder ausgeschaltet.
- Prismatische Sohle
- 80kg + 130kg Haltekraft

Construction:

- holding device for test indicators and dial gauges 3/8" and 8 mm stem
- The magnet is switched on or off by a rotary knob
- prismatic base
- 80kg + 130 kg holding force

Type:

- Mécanisme de fixation pour indicateurs à levier et comparateurs queue de serrage 3/8" et 8 mm
- Marche / arrêt de l'aimant par interrupteur
- Semelle prismatique
- Force de maintien 80 kg + 130 kg

Lieferumfang:

- Garantieschein
- Bedienungsanleitung

Delivery:

- Warranty card
- Instruction manual

Livraison avec:

- Certificat de garantie
- Mode d'emploi

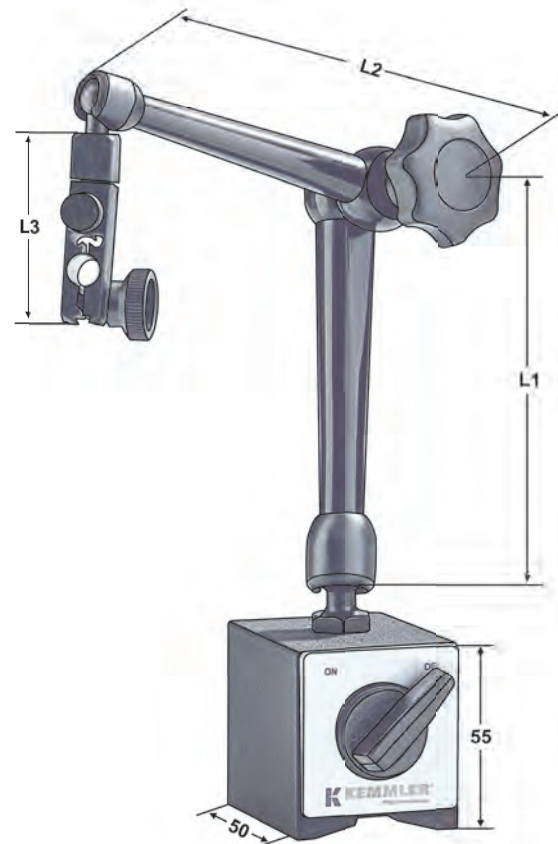

Bestell-Nr. Order no. Références	Haftkraft Prisma Adhesive force prism Force d'adhérence prisme	Prisma Prism Prisme	Aufnahmebohrung Mounting hole Alésage de logement	L1	L2	L3
M.602.02.1	80kg	60x50x55 (LxWxH)	Ø 3/8" + 8 mm	110	101	73
M.602.05.1	130kg	117x50x55 (LxWxH)	Ø 3/8" + 8 mm	285	225	76

Digital height gauge with hand wheel Trusquin avec volant

Kal.-Zertifikat

mm / inch

Ausführung:

- Auflösung: .0005" / 0.01 mm
- extra großes LCD display
- Verstellung über Handrad
- inch/metrisch
- Ausgangsposition wird beim Wiederanschalten beibehalten
- Auswechselbare Hartmetall Anreißnadel
- Nullstellung bei jeder Position möglich

Construction:

- Resolution: .0005" / 0.01mm
- Large LCD display
- Hand wheel design for fine adjustment
- Metric/Inch conversion at any position
- Starting position is kept when turned on
- Exchangeable carbide tipped scriber
- Zero-setting at any position

Type:

- Résolution: .0005" / 0.01 mm
- Affichage LCD extra large
- Réglage par volant
- Inch / métrique
- Position initiale maintenue lors de mise en marche
- Pointe à tracer en carbure interchangeable
- Remise à zero possible à chaque position

Lieferumfang:

- Hartmetall Anreißnadel mit Halterung
- Garantieschein
- Bedienungsanleitung
- Kalibrierzertifikat
- LR44 1,5V Batterie

Delivery:

- Carbide tipped scriber with clamp
- Warranty card
- Instruction manual
- Calibration certificate
- LR44 1,5V Battery

Livraison avec:

- Pointe à tracer en carbure avec support
- Certificat de garantie
- Mode d'emploi
- Certificat de calibrage
- Pile LR44 1,5V

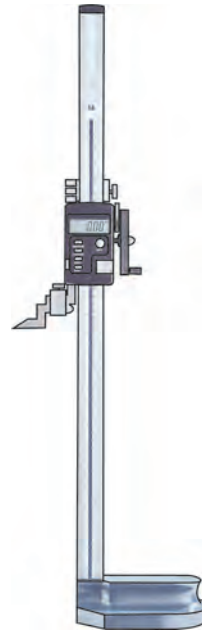

Bestell-Nr. Order no. Références	Messbereich Range Gamme de mesure	Skalenwert Scala Gamme	Genauigkeit Accuracy Précision
M.626.12.0	0 - 300	0,01	± 0,04
M.626.24.0	0 - 600	0,01	± 0,05



12.58



Digitales Höhenmess- und Anreißgerät

Digital height gauge Trusquin

Kal.-Zertifikat

mm / inch

Absolut-System

Ausführung:

- Auflösung: .0005" / 0.01 mm
- extra großes LCD display
- Verstellung über Handrad
- inch/metrisch
- Ausgangsposition wird beim Wiederanschalten beibehalten
- Auswechselbare Hartmetall Anreißnadel
- Schaltet automatisch ab
- Nullstellung bei jeder Position möglich

Construction:

- Resolution: .0005" / 0.01mm
- Large LCD display
- Hand wheel design for fine adjustment
- Metric/Inch conversion at any position
- Starting position is kept when turned on
- Exchangeable carbide tipped scriber
- Automatic switch off
- Zero-setting at any position

Type:

- Résolution: .0005" / 0.01 mm
- Affichage LCD extra large
- Réglage par volant
- Inch / métrique
- Position initiale maintenue lors de mise en marche
- Pointe à tracer en carbure interchangeable
- Arrêt automatique
- Remise à zero possible à chaque position

Lieferumfang:

- Hartmetall Anreißnadel mit Halterung
- Garantieschein
- Bedienungsanleitung
- Kalibrierzertifikat
- LR44 1,5V Batterie

Delivery:

- Carbide tipped scriber with clamp
- Warranty card
- Instruction manual
- Calibration certificate
- LR44 1,5V Battery

Livraison avec:

- Pointe à tracer en carbure avec support
- Certificat de garantie
- Mode d'emploi
- Certificat de calibrage
- Pile LR44 1,5V



Bestell-Nr. Order no. Références	Messbereich Range Gamme de mesure	Skalenwert Scala Gamme	Genauigkeit Accuracy Précision
M.625.12.0	0 - 300	0,01	± 0,04
M.625.24.0	0 - 600	0,01	± 0,05



12.58

Digital height gauge with hand wheel Trusquin avec volant

Kal.-Zertifikat

mm / inch

Absolut-System

Ausführung:

- Auflösung: .0005" / 0.01 mm
- extra großes LCD display
- Verstellung über Handrad
- inch/metrisch
- Ausgangsposition wird beim Wiederanschalten beibehalten
- Auswechselbare Hartmetall Anreißnadel
- Schaltet automatisch ab
- Nullstellung bei jeder Position möglich

Construction:

- Resolution: .0005" / 0.01mm
- Large LCD display
- Hand wheel design for fine adjustment
- Metric/Inch conversion at any position
- Starting position is kept when turned on
- Exchangeable carbide tipped scriber
- Automatic switch off
- Zero-setting at any position

Type:

- Résolution: .0005" / 0.01 mm
- Affichage LCD extra large
- Réglage par volant
- Inch / métrique
- Position initiale maintenue lors de mise en marche
- Pointe à tracer en carbure interchangeable
- Arrêt automatique
- Remise à zero possible à chaque position

Lieferumfang:

- Hartmetall Anreißnadel mit Halterung
- Garantieschein
- Bedienungsanleitung
- Kalibrierzertifikat
- LR44 1,5V Batterie

Delivery:

- Carbide tipped scriber with clamp
- Warranty card
- Instruction manual
- Calibration certificate
- LR44 1,5V Battery

Livraison avec:

- Pointe à tracer en carbure avec support
- Certificat de garantie
- Mode d'emploi
- Certificat de calibrage
- Pile LR44 1,5V



Bestell-Nr. Order no. Références	Messbereich Range Gamme de mesure	Skalenwert Scala Gamme	Genauigkeit Accuracy Précision
M.627.12.0	0 - 300	0,01	± 0,02
M.627.24.0	0 - 600	0,01	± 0,03



12.58

K Höhenmess- und Anreissgerät | analog

Vernier height gauge | analogue
Trusquin | analogique

Kal.-Zertifikat mm / inch INOX

Ausführung:

- Ablesung: 0.05mm / 1/128"
- Durch die Feineinstellung kann der Schieber exakt positioniert werden
- Mattes Chrom finish
- Wärmeisolierender Kunststoffgriff

Construction:

- Graduation: 0.05mm / 1/128"
- The fine-adjustment allows the slider to be precisely positioned
- Matt chrome finish
- Stainless steel design
- The base is designed with a thermal heat isolation hand grip

Type:

- Lecture: 0.05 mm / 1 / 128"
- Par le réglage fin le poussoir peut être positionné précisément
- Chromé mat
- Poignée plastique isolante

Lieferumfang:

- Hartmetall Anreißnadel mit Halterung
- Garantieschein
- Bedienungsanleitung
- Kalibrierzertifikat

Delivery:

- Carbide tipped scriber with clamp
- Warranty card
- Instruction manual
- Calibration certificate

Livraison avec:

- Pointe à tracer en carbure avec support
- Certificat de garantie
- Mode d'emploi
- Certificat de calibrage



12

Bestell-Nr. Order no. Références	Messbereich Range Gamme de mesure	Skalenwert Scala Gamme	Genauigkeit Accuracy Précision
M.621.12.0	0 - 300	0,05	± 0,05
M.621.24.0	0 - 600	0,05	± 0,10

Präzisions-Haarwinkel, DIN 875 / 00



Prec. bevelled edge, DIN 875 / 00
Equerres biseautées, DIN 875 / 00

DIN 875

INOX

Ausführung:

- Hergestellt aus gehärtetem Edelstahl
- Gefertigt nach DIN 875

Construction:

- *Made of precision ground hardened stainless steel*
- *Accuracy according to DIN 875*

Type:

- En acier inoxydable trempée
- Fabriqué selon DIN 875



Bestell-Nr. Order no. Références	Abmessung Size Dimension
M.639.22.0	75 x 50
M.639.23.0	100 x 70
M.639.24.0	150 x 100
M.639.25.0	200 x 130
M.639.27.0	300 x 200

Präzisions-Flachwinkel, DIN 875 / 0

Prec. flat square, DIN 875 / 0
Equerres simples, DIN 875 / 0

DIN 875

INOX

Ausführung:

- Hergestellt aus gehärtetem Edelstahl
- Gefertigt nach DIN 875

Construction:

- *Made of precision ground hardened stainless steel*
- *Accuracy according to DIN 875*

Type:

- En acier inoxydable trempée
- Fabriqué selon DIN 875



Bestell-Nr. Order no. Références	Abmessung Size Dimension
M.639.22.4	75 x 50
M.639.23.4	100 x 70
M.639.24.4	150 x 100
M.639.25.4	200 x 130
M.639.27.4	300 x 200



Winkelmesser Satz mit Feineinstellung und Lupe

Universal bevel protractor set with fine adjustment
Jeux de rapporteur d'angle à loupe

Kal.-Zertifikat

mm / inch

INOX

Ausführung:

- Ablesung: 1°, Noniuswert 5'
- Für präzise Winkelmessungen
- Vergrößerungsglas für leichteres Ablesen
- Kann mit einem Standard Höhenmessgerät genutzt werden um einen Winkel zur Referenzplatte zu erhalten
- Genauigkeit: ± 5 min

Construction:

- Dial Graduation: 1°, Vernier: 5'
- Designed to provide precise angular measurements
- Magnifying glass is provided for easier reading
- Can be used with a standard height gauge to provide angular measurement from reference plate
- Accuracy: ±5 min

Type:

- Graduation: 1°, vernier 5'
- Pour mesures d'angles exactes
- Loupe pour lecture facilitée
- Utilisation avec trusquin standard pour obtenir un angle par rapport au plat de référence
- Précision: ±5 min

Lieferumfang:

- Basis + Messschienen
- Garantieschein
- Bedienungsanleitung
- Kalibrierzertifikat

Delivery:

- Base + Blades
- Warranty card
- Instruction manual
- Calibration certificate

Livraison avec:

- Base + barres de mesure
- Certificat de garantie
- Mode d'emploi
- Certificat de calibrage



Bestell-Nr.
Order no.
Références

M.490.06.0

Messbereich
Range
Gamme de mesure

4 x 90°

Schiene
Blade
Barre

150+200+300

Genauigkeit
Accuracy
Précision

± 5 min

Digital protractor 0-360°

Rapporteur d'angle numérique 0-360°

Kal.-Zertifikat

mm / inch

INOX

Ausführung:

- Ablesung: 1°, Noniuswert 5'
- Für präzise Winkelmessungen
- Vergrößerungsglas für leichteres Ablesen
- Kann mit einem Standard Höhenmessgerät genutzt werden, um einen Winkel zur Referenzplatte zu erhalten
- Genauigkeit: ± 5 min

Construction:

- Resolution: 30"/0.008°
- Measuring Range: 0-360°
- Range selection: 1 x 360°, 2 x 180°, 4 x 90°
- Dual reading LCD display arc minutes / decimal degrees
- With fine adjustment
- Preset function
- Accuracy: ± 5 min

Type:

- Avec répéteur de la tension du ressort
- La tension du ressort ce fait par pré réglage avec marquage
- Positions de serrage: horizontale, verticale ou latérale
- Corps en acier trempé et rectifié sur toutes les faces
- Répression basse incorporée
- Hauteur du socle H: $\leq 0,01$ mm

Lieferumfang:

- Basis + Messschienen
- Garantieschein
- Bedienungsanleitung
- Kalibrierzertifikat
- CR2032 3,0V Batterie

Delivery:

- Base + Blades
- Warranty card
- Instruction manual
- Calibration certificate
- CR2032 3,0V Battery

Livraison avec:

- Base + barres de mesure
- Certificat de garantie
- Mode d'emploi
- Certificat de calibrage
- Pile CR2032 3,0V



Bestell-Nr. Order no. Références	Messbereich Range Gamme de mesure	Schiene Blade Barre	Genauigkeit Accuracy Précision
M.490.15.2	360°	150 + 300	± 5 min





Stahl Parallelendmaß Satz

Rectangular gauge block set
Jeu de cales étalons parallèles en acier

Kal.-Zertifikat



Ausführung:

- Individuelle Seriennummern auf jedem Block
- Ein auf N.I.S.T. oder P.T.B. rückführbares Kalibrierzertifikat zeigt die Abweichung jedes Maßes
- Feingeläppte Oberfläche

Construction:

- Individual serial numbers on each block, regardless of grade
- A complete certificate of calibration traceable to the N.I.S.T or P.T.B showing the deviation of each block
- Mirror polished surfaces

Type:

- Numéro de série individuel
- Certificat de calibrage équivalent à N.I.S.T. ou P.T.B. indique écarts de tolérance
- Surface rodée finement

Bestell-Nr. Order no. Références	Toleranzklasse Tolerance class Classe de tolérance	Anzahl Endmaße Number of gauge blocks Nombre de cales étalons
M.650.16.0	0	= 32 = 1 St. pcs. : 1.005mm 9 St. pcs. : 1.01 - 1.09mm x 0.01mm Stufung step pas 9 St. pcs. : 1.1 - 1.9mm x 0.1mm Stufung step pas 9 St. pcs. : 1- 9mm x 1mm Stufung step pas 4 St. pcs. : 10mm 20mm 30mm 50mm
M.650.16.2	2	= 32 = 1 St. pcs. : 1.005mm 9 St. pcs. : 1.01 - 1.09mm x 0.01mm Stufung step pas 9 St. pcs. : 1.1 - 1.9mm x 0.1mm Stufung step pas 9 St. pcs. : 1- 9mm x 1mm Stufung step pas 4 St. pcs. : 10mm 20mm 30mm 50mm
M.650.14.0	0	= 47 = 1 St. pcs. : 1.005mm 20 St. pcs. : 1.01- 1.20mm x 0.01mm Stufung Stufung step pas 7 St. pcs. : 1.3 - 1.9mm x 0.1mm Stufung Stufung step pas 9 St. pcs. : 1- 9mm x 1mm Stufung Stufung step pas 10 St. pcs. : 10 - 100mm x 10mm Stufung Stufung step pas
M.650.14.2	2	= 47 = 1 St. pcs. : 1.005mm 20 St. pcs. : 1.01- 1.20mm x 0.01mm Stufung Stufung step pas 7 St. pcs. : 1.3 - 1.9mm x 0.1mm Stufung Stufung step pas 9 St. pcs. : 1- 9mm x 1mm Stufung Stufung step pas 10 St. pcs. : 10 - 100mm x 10mm Stufung Stufung step pas
M.650.13.0	0	= 87 = 9 St. pcs.: 1.001- 1.009mm x 0.001mm Stufung step pas 49 St. pcs.: 1.01- 1.49mm x 0.01mm Stufung step pas 19 St. pcs.: 0.5 - 9.5mm x 0.5mm Stufung step pas 10 St. pcs.: 10 - 100mm x 10mm Stufung step pas
M.650.13.2	2	= 87 = 9 St. pcs.: 1.001- 1.009mm x 0.001mm Stufung step pas 49 St. pcs.: 1.01- 1.49mm x 0.01mm Stufung step pas 19 St. pcs.: 0.5 - 9.5mm x 0.5mm Stufung step pas 10 St. pcs.: 10 - 100mm x 10mm Stufung step pas
M.650.12.0	0	= 103 = 1 St. pcs.: 1.005mm 49 St. pcs.: 1.01- 1.49mm x 0.01mm Stufung step pas 49 St. pcs.: 0.5- 24.5mm x 0.5mm Stufung step pas 4 St. pcs.: 25 - 100mm x 25mm Stufung step pas
M.650.12.2	2	= 103 = 1 St. pcs.: 1.005mm 49 St. pcs.: 1.01- 1.49mm x 0.01mm Stufung step pas 49 St. pcs.: 0.5- 24.5mm x 0.5mm Stufung step pas 4 St. pcs.: 25 - 100mm x 25mm Stufung step pas



Technische Datenblätter, STEP/STL Modelle für die Simulation der NC-Programme und DXF-Zeichnungen zur Erstellung des Einrichteblattes stehen Online zur Verfügung.

Technical data sheets, STEP/STL models for the simulation of NC programs and DXF drawings to create the tooling sheet are online available.

Fiches techniques, STEP/STL modèles techniques pour la simulation de programmes CN et dessins DXF pour créer la feuille d'installation sont disponible online.

Sie können unsere Kataloge entweder direkt im Browser betrachten oder sie auf Ihren PC, Smartphone oder Tablet herunterladen (PDF-Reader notwendig).

You can view our catalogues either directly in the browser or download to your PC, smartphone or tablet (PDF reader required).

Vous pouvez consulter nos catalogues directement dans le navigateur ou télécharger sur votre PC, smartphone ou tablet (lecteur PDF requis).

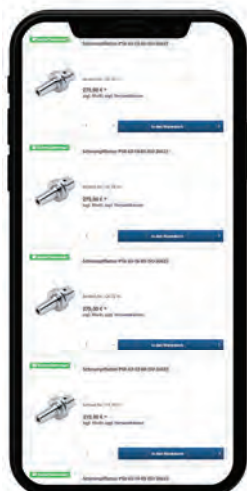

Auf unserer Internetseite können Sie die Lagerverfügbarkeit prüfen - auch auf Mobilgeräten.

On our website you can check the stock availability - also on mobile devices.

Vous pouvez également vérifier la disponibilité de nos produits sur le site Internet - ainsi que sur vos appareils

Plug gauge | H7 Tampon lisse | H7

DIN
7162/7164

DIN 2245

Kal.-Zertifikat

Ausführung:

- Gehärteter Lehenstahl
- Grenzlehrdorn-Genauigkeit DIN 7162/7164
- Grenzlehrdorn-Größe DIN 2245

Construction:

- Hardened steel
- Plug Gauge Accuracy according to DIN 7162/7164
- Plug gauge sizes according to DIN 2245

Type:

- En acier calibré, trempé
- Précision tampons lisses DIN 7162/7164
- Taille tampons lisses DIN 2245



Bestell-Nr. Order no. Références	Messbereich Range Gamme de mesure
M.670.02.7	2mm
M.670.03.7	3mm
M.670.04.7	4mm
M.670.05.7	5mm
M.670.06.7	6mm
M.670.07.7	7mm
M.670.08.7	8mm
M.670.09.7	9mm
M.670.10.7	10mm
M.670.11.7	11mm
M.670.12.7	12mm
M.670.13.7	13mm
M.670.14.7	14mm
M.670.15.7	15mm
M.670.16.7	16mm
M.670.17.7	17mm
M.670.18.7	18mm
M.670.19.7	19mm
M.670.20.7	20mm
M.670.21.7	21mm
M.670.22.7	22mm
M.670.23.7	23mm
M.670.24.7	24mm
M.670.25.7	25mm
M.670.26.7	26mm
M.670.27.7	27mm
M.670.28.7	28mm
M.670.30.7	30mm
M.670.32.7	32mm

Bestell-Nr. Order no. Références	Messbereich Range Gamme de mesure
M.670.34.7	34mm
M.670.35.7	35mm
M.670.36.7	36mm
M.670.37.7	37mm
M.670.38.7	38mm
M.670.40.7	40mm
M.670.42.7	42mm
M.670.44.7	44mm
M.670.45.7	45mm
M.670.46.7	46mm
M.670.47.7	47mm
M.670.48.7	48mm
M.670.50.7	50mm
M.670.52.7	52mm
M.670.55.7	55mm
M.670.60.7	60mm
M.670.62.7	62mm
M.670.65.7	65mm
M.670.68.7	68mm
M.670.70.7	70mm
M.670.72.7	72mm
M.670.75.7	75mm
M.670.80.7	80mm
M.670.85.7	85mm
M.670.90.7	90mm
M.670.95.7	95mm
M.670.98.7	98mm

Ring gauge Bague de réglage

DIN
7162/7164

DIN 2245

Kal.-Zertifikat

Ausführung:

- Gehärteter Lehenstahl
- Leehring-Genauigkeit DIN 2250

Construction:

- *Hardened steel*
- *Ring gauge accuracy according to DIN 2250*

Type:

- En acier calibré, trempé
- Précision bagues lisses selon DIN 2250



Bestell-Nr. Order no. Références	Messbereich Range Gamme de mesure
M.675.02.0	2mm
M.675.02.2	2,2mm
M.675.02.5	2,5mm
M.675.02.8	2,8mm
M.675.03.0	3mm
M.675.03.5	3,5mm
M.675.04.0	4mm
M.675.04.5	4,5mm
M.675.05.0	5mm
M.675.06.0	6mm
M.675.07.0	7mm
M.675.08.0	8mm
M.675.09.0	9mm
M.675.10.0	10mm
M.675.11.0	11mm
M.675.12.0	12mm
M.675.13.0	13mm
M.675.14.0	14mm
M.675.15.0	15mm
M.675.16.0	16mm
M.675.17.0	17mm
M.675.18.0	18mm
M.675.19.0	19mm
M.675.20.0	20mm
M.675.21.0	21mm
M.675.22.0	22mm
M.675.23.0	23mm
M.675.24.0	24mm
M.675.25.0	25mm
M.675.26.0	26mm
M.675.27.0	27mm
M.675.28.0	28mm
M.675.30.0	30mm
M.675.32.0	32mm

Bestell-Nr. Order no. Références	Messbereich Range Gamme de mesure
M.675.33.0	33mm
M.675.34.0	34mm
M.675.35.0	35mm
M.675.36.0	36mm
M.675.37.0	37mm
M.675.38.0	38mm
M.675.40.0	40mm
M.675.42.0	42mm
M.675.44.0	44mm
M.675.45.0	45mm
M.675.46.0	46mm
M.675.47.0	47mm
M.675.48.0	48mm
M.675.50.0	50mm
M.675.52.0	52mm
M.675.55.0	55mm
M.675.58.0	58mm
M.675.60.0	60mm
M.675.62.0	62mm
M.675.65.0	65mm
M.675.68.0	68mm
M.675.70.0	70mm
M.675.72.0	72mm
M.675.75.0	75mm
M.675.80.0	80mm
M.675.82.0	82mm
M.675.85.0	85mm
M.675.88.0	88mm
M.675.90.0	90mm
M.675.92.0	92mm
M.675.95.0	95mm
M.675.98.0	98mm
M.676.00.0	100mm

Thread plug gauge | 6H Tampons filetés doubles | 6H

DIN 13

Kal.-Zertifikat

Ausführung:

Der angeschliffene erste Gewindengang entfernt groben Schmutz im Werkstück und verhindert das vorzeitige Ausbrechen des ersten Gewindenganges.

Gut- und Ausschusseite auf einem Griff (DIN 2240, Teil 1, Form R). Ausschusseite rot gekennzeichnet.

Bei Gewinden grösser als M40 sind Gut- und Ausschusdorn separat (DIN 2240, Teil 2, Form GE)

- Gehärteter Lehenstahl
- ISO-metrisches Gewinde
- DIN 13
- 6H
- Toleranzen und Abmaße nach DIN ISO 1502
- Ausführung gemäß DIN 2279 – 2299

Construction:

The ground first thread pitch removes coarse swarf in the component and prevents premature fracture of the first thread pitch.

“Go” and “No Go” ends on a single handle (DIN 2240, part 1, form R). “No Go” end marked red.

M40 and above “Go” and “No Go” gauges are separate (DIN 2240, part 2, form GE)

- Hardened steel
- ISO-Metric Thread
- DIN 13
- 6H
- Tolerances and dimensions to DIN ISO 1502
- Version to DIN 2279 - 2299

Type:

Le premier pas est tronqué pour éliminer les impuretés sur la pièce et empêche le dérapage prématuré du premier pas.

Côté ENTRE et N'ENTRE PAS sur une poignée (DIN 2240, partie 1, forme R). Côté N'ENTRE PAS marqué en rouge.

Chez les filets qui sont plus grands que M40 les tampons ENTRE et N'ENTRE PAS sont séparés (DIN 2240, partie 2, forme GE).

- En acier calibré, trempé
- Filetage métrique iso
- DIN 13
- 6H
- Tolérances et dimensions suivant DIN ISO 1502
- Exécution suivant DIN 2279 – 2299



Bestell-Nr. Order no. Références	Gewinde Thread Filetage	Steigung Thread lead Pas de filetage
M.680.02.0	M2	0,40
M.680.02.5	M2,5	0,45
M.680.03.0	M3	0,50
M.680.03.5	M3,5	0,60
M.680.04.2	M4	0,70
M.680.05.2	M5	0,80
M.680.06.2	M6	1,00
M.680.08.2	M8	1,25
M.680.09.2	M9	1,25
M.680.10.2	M10	1,50
M.680.12.2	M12	1,75
M.680.14.2	M14	2,00
M.680.16.2	M16	2,00
M.680.18.2	M18	2,50
M.680.20.2	M20	2,50
M.680.22.2	M22	2,50
M.680.24.2	M24	3,00
M.680.27.2	M27	3,00
M.680.30.2	M30	3,50
M.680.33.2	M33	3,50
M.680.36.2	M36	4,00
M.680.39.2	M39	4,00
M.680.42.2	M42	4,50
M.680.45.2	M45	4,50
M.680.48.2	M48	5,00
M.680.52.2	M52	5,00
M.680.56.2	M56	5,50
M.680.60.2	M60	5,50

Ring gauge „GO“ | Ring gauge „NO GO“ | 6g
 Bague filetée ENTRE | Bague filetée N'ENTRE PAS | 6g

DIN 13

Kal.-Zertifikat

Ausführung:

- Gehärteter Lehenstahl
- ISO-metrisches Gewinde
- DIN 13
- 6g

Construction:

- Hardened steel
- ISO-Metric Thread
- DIN 13
- 6g

Type:

- En acier calibré, trempé
- Filetage métrique iso
- DIN 13
- 6g

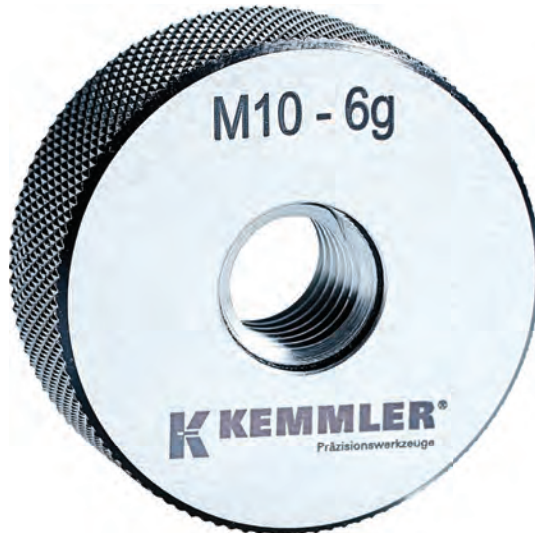

Bestell-Nr. Order no. Références	Messbereich „Go“ Range „Go“ Gamme de mesure „Go“
M.683.03.1	M3
M.683.03.6	M3,5
M.683.04.1	M4
M.683.05.1	M5
M.683.06.1	M6
M.683.08.1	M8
M.683.09.1	M9
M.683.10.1	M10
M.683.12.1	M12
M.683.14.1	M14
M.683.16.1	M16
M.683.18.1	M18
M.683.20.1	M20
M.683.22.1	M22
M.683.24.1	M24
M.683.27.1	M27
M.683.30.1	M30
M.683.33.1	M33
M.683.36.1	M36
M.683.39.1	M39
M.683.42.1	M42
M.683.45.1	M45
M.683.48.1	M48
M.683.52.1	M52
M.683.56.1	M56
M.683.60.1	M60

Bestell-Nr. Order no. Références	Messbereich „No Go“ Range „No Go“ Gamme de mesure „No Go“
M.684.03.0	M3
M.684.03.5	M3,5
M.684.04.0	M4
M.684.05.0	M5
M.684.06.0	M6
M.684.08.0	M8
M.684.09.0	M9
M.684.10.0	M10
M.684.12.0	M12
M.684.14.0	M14
M.684.16.0	M16
M.684.18.0	M18
M.684.20.0	M20
M.684.22.0	M22
M.684.24.0	M24
M.684.27.0	M27
M.684.30.0	M30
M.684.33.0	M33
M.684.36.0	M36
M.684.39.0	M39
M.684.42.0	M42
M.684.45.0	M45
M.684.48.0	M48
M.684.52.0	M52
M.684.56.0	M56
M.684.60.0	M60



Kantentaster mechanisch

Edge finders mechanical
Palpeurs d'angle mécanique



Verwendung:
Zum Ausrichten von Werkstück-Bezugsflächen oder Kanten. Drehzahl der Spindel ca. 600 U/min.

Application:
For alignment of component reference surfaces or edges. Spindle speed approx. 600 rpm.

Application:
Pour aligner les surfaces de référence ou les arêtes de pièces à usiner. Vitesse env. 600 tr/min.

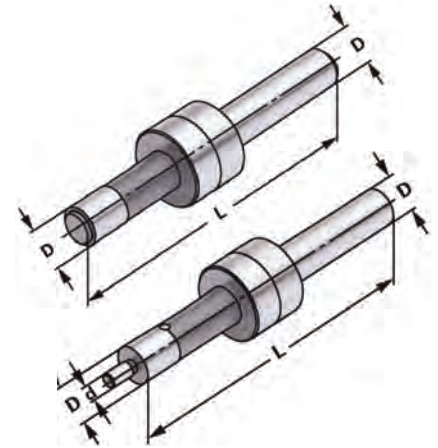

Bestell-Nr. Order no. Référence	D	L	d
702.10	10	84	-
702.10.4	10	94	4

Ausführung: Der Tastkopf ist über eine Feder mit dem Einspannschaft elastisch verbunden und ermöglicht eine Ausricht-Genauigkeit von 0,01 mm. Alle Teile ganz gehärtet und geschliffen.
Gr. 10: Mit einfachem Tastkopf 10 mm Ø.
Gr. 10/4: Mit abgesetztem Tastkopf 10 und 4 mm Ø.

Version: The contact point has a flexible connection to the body via a spring, with an alignment accuracy of 0.01 mm. All parts fully hardened and ground.
Size 10: With parallel contact point 10 mm Ø.
Size 10/4: With stepped contact point 10 and 4 mm Ø.

Exécution: La pinule est assemblée par un ressort et permet une précision d'alignement de 0,01 mm. Toutes les pièces sont entièrement trempées et rectifiées.
Réf. 10: Avec palpeur simple Ø 10 mm.
Réf. 10/4: Pinule avec épaulement Ø 10 ou 4 mm.



Verwendung:
Ersatzfeder für Kantentaster 702.10 + 702.10.4

Application:
Springs for edgefinder 702.10 + 702.10.4

Application:
Ressorts pour palpeurs d'angle mécanique pour 702.10 + 702.10.4

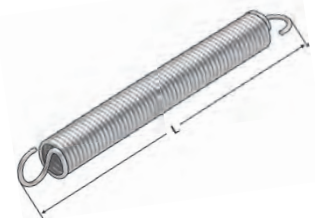

Bestell-Nr. Order no. Référence	L
702.E10-10.4	44

Edge finders electronic 2D Palpeurs d'angle électroniques 2D



Verwendung:
Ausrichten von Werkstück-Bezugsflächen oder Kanten. Bestimmen von Bohrungsmittelpunkten zentrisch zur Arbeitsspindel.

Application:
Alignment of component reference surfaces or edges. Determination of bore centres to the machine spindle.

Application:
Pour aligner les surfaces de référence ou les arêtes de pièces à usiner. Détermination du point central d'un perçage par rapport à la broche d'entraînement.

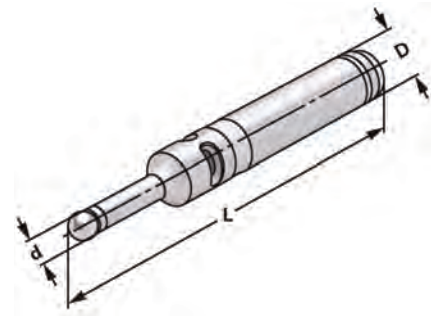

Bestell-Nr. Order no. Référence	D	L	d
702.16	16	100	10
702.20	20	160	10

Ausführung: Federgelagerte Tastkugel schützt das Gerät vor Beschädigung, falls zu stark angefahren wird. Funktionsteile gehärtet und geschliffen. Rundlauf-Genauigkeit: $\pm 0,01$ mm.

Version: Spring mounted spherical tip protects the unit from damage if contact is too strong. Functional parts hardened and ground. Concentricity: ± 0.01 mm.

Exécution: Les billes évitent tout dommage à l'outil en cas de contact fort. Pièces de fonctionnement trempées et rectifiées. Précision de concentricité: $\pm 0,01$ mm.

Funktion: Bei Kontakt von Tastkugel und metallischem Werkstück bringen Batterien die Lampe zum Leuchten = Erkennen des Bezugspunktes.

Function: When contact between the spherical tip and metal component occurs, the control lamp lights up = identification of the reference point.

Fonctionnement: Au contact de la bille et de la pièce métallique à usiner, la lampe de contrôle s'allume = identification du point de référence.

Lieferumfang: CR2032 3,0V Batterie
Delivery: CR2032 3,0V Battery
Livraison avec: Pile CR2032 3,0V



12.58



Kantentaster elektronisch 3D

Edge finders electronic 3D
Palpeurs d'angle électroniques 3D



Verwendung:
Ausrichten von Werkstück-Bezugsflächen oder Kanten. Bestimmen von Bohrungsmittelpunkten zentrisch zur Arbeitsspindel.

Application:
Alignment of component reference surfaces or edges. Determination of bore centres to the machine spindle.

Application:
Pour aligner les surfaces de référence ou les arêtes de pièces à usiner. Détermination du point central d'un perçage par rapport à la broche d'entraînement.

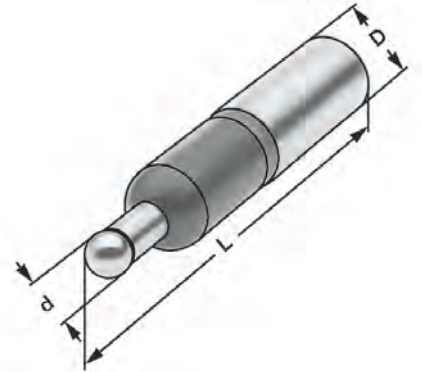

Bestell-Nr.
Order no.
Référence

D

L

d

702.3.16

16

110

10

702.3.20

20

106

10

Ausführung: Federnd gelagerte Tastkugel schützt das Gerät vor Beschädigung, falls zu stark angefahren wird. Funktionsteile gehärtet und geschliffen. Rundlauf-Genauigkeit: $\pm 0,01$ mm.

Version: *The spring-mounted spherical tip protects the unit from damage if contact is too strong. Functional parts hardened and ground. Concentricity: ± 0.01 mm.*

Exécution: Les billes sont montées sur ressort pour éviter tout dommage à l'outil en cas de contact fort. Pièces de fonctionnement trempées et rectifiées. Précision de concentricité: $\pm 0,01$ mm.

Funktion: Bei Kontakt von Tastkugel und metallischem Werkstück bringen Batterien die Lampe zum Leuchten = Erkennen des Bezugspunktes.

Function: *When contact between the spherical tip and metal component occurs, the control lamp lights up = identification of the reference point.*

Fonctionnement: Au contact de la bille et de la pièce métallique à usiner, la lampe de contrôle s'allume = identification du point de référence.

Lieferumfang: 1,5 V | LR1 / N / Lady Batterie

Delivery: 1,5 V | LR1 / N / Lady Battery

Livraison avec: 1,5 V | LR1 / N / Lady Pile



Edge finders electronic 3D Palpeurs d'angle électroniques 3D



Verwendung:
Ausrichten von Werkstück-Bezugsflächen oder Kanten. Bestimmen von Bohrungsmittelpunkten zentrisch zur Arbeitsspindel.

Application:
Alignment of component reference surfaces or edges. Determination of bore centres to the machine spindle.

Application:
Pour aligner les surfaces de référence ou les arêtes de pièces à usiner. Détermination du point central d'un perçage par rapport à la broche d'entraînement.

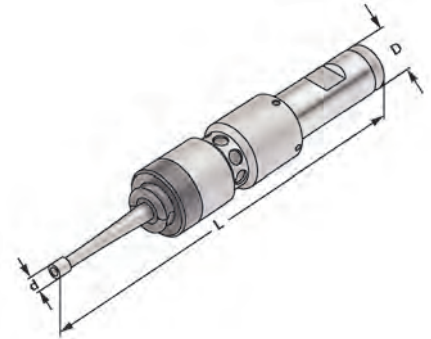

Bestell-Nr.
Order no.
Référence

702.6.20

D
20

l
54

L
173

d
6

Ausführung: Der Tastkopf ist über eine Feder mit dem Einspannschaft elastisch verbunden und ermöglicht eine Ausricht-Genauigkeit von 0,01 mm. Alle Teile ganz gehärtet und geschliffen.

Version: *The contact point has a flexible connection to the body via a spring, with an alignment accuracy of 0.01 mm. All parts fully hardened and ground.*

Exécution: La pinule est assemblée par un ressort et permet une précision d'alignement de 0,01 mm. Toutes les pièces sont entièrement trempées et rectifiées.

Funktion: Bei Kontakt mit dem metallischen Werkstück bringen Batterien die Lampe zum Leuchten = Erkennen des Bezugspunktes.

Function: *When contact with the metal component occurs, the control lamp lights up = identification of the reference point.*

Fonctionnement: Au contact de la pièce métallique à usiner, la lampe de contrôle s'allume = identification du point de référence.

Lieferumfang: 1,5 V | LR1 / N / Lady Batterie

Delivery: 1,5 V | LR1 / N / Lady Battery

Livraison avec: 1,5 V | LR1 / N / Lady Pile



12.58



Kantentaster mechanisch 3D

Edge finders mechanical 3D
Palpeurs d'angle mécanique 3D



Verwendung:
Zum Werkstück-Nullpunkt suchen und setzen in 3 Achsen x,y und z.

Application:
Search for the neutral point and raise in 3-axis, x, y and z.

Application:
Recherche du point zéro pièce et mise en place dans 3 axes, x, y et z.

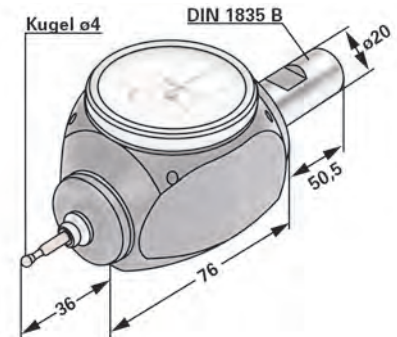

Bestell-Nr.
Order no.
Référence

702.7.20

3D | 20 - 4 - 162,50

Ausführung: Mit dem Kantentaster, die als Nullpunkt vorgesehene Werkstückkante in x- oder y-Richtung anfahren, bis beide Zeiger der Meßuhr auf Null stehen, dann ist die Antastkante gleich der Spindelachse. In z-Richtung direkte Wegmessung.
IP 67 spritzwassergeschützt

Version: *Raise the tool edge assigned as neutral point in x- or y-way with the edge sensor until both pointers of the dial gage are at zero. At that moment the key-edge is equal to the spindle-axis. In z-way direct way-measurement.*
IP 67 waterproof

Exécution: Avec le palpeur d'arêtes, approcher dans le sens x ou y l'arête de la pièce prévue pour être le point zéro, jusqu'à ce que les deux aiguilles du comparateur solant à zéro; l'arête de palpation est alors égal à l'axe de la broche. Dans le sens z, mesure directe de la course.
protection contre les projections d'eau IP 67

Null-Einstellgeräte mit Magnet



Z-Axis Zero-setters with magnet

Appareils de réglage du zéro avec aimant

Referenzhöhe / Hight / Hauteur 50 mm



Verwendung:

Zum Einstellen der Werkzeuge (z. B. Fräser) auf Null und zum Bestimmen des Referenzpunktes der Maschinenspindel.

Application:

For setting tools (e.g. end mills) to "zero" and for determining the reference point of the machine spindle.

Application:

Pour la mise à zéro d'outils (p. ex. fraiseuses) et la détermination du point de référence de la broche de la machine.

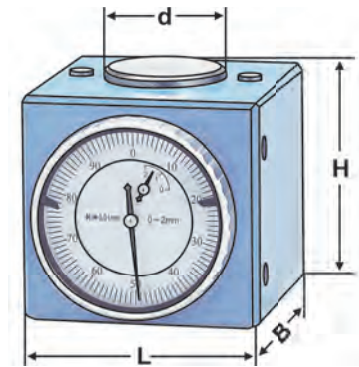

Bestell-Nr.
Order no.
Référence

702.5.48.2

Mit Magnet
with magnet
avec aimant

L

52

B

52

H

50

d

25

Null-Einstellgeräte ohne Magnet

Z-Axis Zero-setters without magnet

Appareils de réglage du zéro sans aimant

Referenzhöhe / Hight / Hauteur 50 mm



Verwendung:

Zum Einstellen der Werkzeuge (z. B. Fräser) auf Null und zum Bestimmen des Referenzpunktes der Maschinenspindel.

Application:

For setting tools (e.g. end mills) to "zero" and for determining the reference point of the machine spindle.

Application:

Pour la mise à zéro d'outils (p. ex. fraiseuses) et la détermination du point de référence de la broche de la machine.

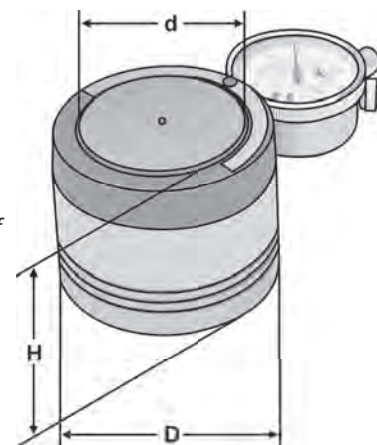

Bestell-Nr.
Order no.
Référence

702.5.48.1

Ohne Magnet
without magnet
avec aimant

D

62

H

50

d

25



Null-Einstellgeräte elektronisch mit Magnet

Electronic Z-Axis Zero-setters with magnet

Appareils de réglage du zéro électronique avec aimant

Referenzhöhe / Hight / Hauteur 50 mm



Verwendung:

Zur Lagebestimmung von Werkstückoberflächen oder Werkzeuglängen in Z-Richtung auf Dreh- oder Fräsmaschinen.

Application:

To determine position of workpiece surfaces or workpiece lengths in Z-direction on lathes or milling machines.

Application:

Pour déterminer la position des surfaces des pièces ou des longueurs de pièces dans le sens Z sur les tours et les fraiseuses.

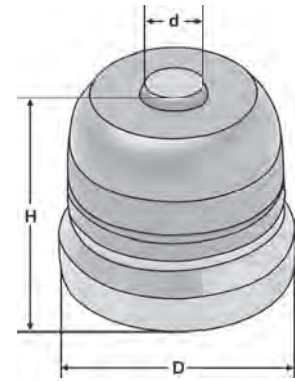

Bestell-Nr.
Order no.
Référence

702.4.19

D

54

H

50

d

14

Funktion: Das Gerät wird auf das Werkstück gestellt. Mit der Spindel fährt man nun vorsichtig auf das Gerät auf. Sobald die LED aufleuchtet hat man das Bezugsmaß 50 mm erreicht. Ein Sicherheitsfederweg von ca. 3 mm zum Überfahren der 50 mm ist eingebaut.

Function: *The apparatus is placed on the workpiece. With the spindle, now move carefully to the device. As soon as the LED lights up, you have achieved the reference value 50 mm. A safety spring way of approx. 3 mm to cross 50 mm is integrated.*

Fonctionnement: Poser l'appareil sur la pièce. S'approcher prudemment de l'appareil avec la broche. La dimension de référence de 50 mm est atteinte dès que la LED s'allume. Course de ressort d'environ 3 mm intégrée permettant de dépasser la cote de 50 mm.

KEMMLER OEM

Laserbeschriftung der Werkzeuge

Laser engraving of toolholders

Marquage laser de porte-outils



Laserbeschriftung von Werkzeugaufnahmen

Durch unsere Laserbeschriftungsanlagen können wir Ihnen individuelle, kostengünstige Laserbeschriftung der Werkzeuge anbieten. Die dauerhafte Beschriftung kann mit Ihrem Firmennamen, Firmenlogo oder mit sonstigen Sonderzeichen erfolgen. Ebenfalls können die Etiketten auf den Verpackungen nach Ihren Vorgaben gestaltet werden.

Laser engraving of toolholders

With our newly acquired laser engravers we can offer you individual and cost-effective engraving of tools. The permanent engraving can include your company's name, logo or any other special description. Also the labels on the packaging can be designed according to your specifications.

Marquage laser de porte-outils

A l'aide de notre dispositif de marquage laser nous sommes en mesure de labelliser vos porte-outils avec votre nom, logo ou autres données. En outre, les étiquettes peuvent être conçues sur l'emballage selon vos spécifications.





Datenverbindungskabel - 2 Meter

Data connection cable - 2 meter
Câble de raccordement - 2 mètre



Bestell-Nr. Order no. Références	Schnittstelle PC Interface PC Interface PC	Schnittstelle Messmittel Interface measuring device Interface appareil de mesure	Daten Data Données
M.900.05.4	USB-A	Micro-USB-B	Punkt Dot Point
M.900.05.5	USB-A	Micro-USB-B	Komma Comma Virgule





Bestell-Nr. Order no. Références	Schnittstelle PC Interface PC Interface PC	Schnittstelle Messmittel Interface measuring device Interface appareil de mesure	Daten Data Données
M.900.07.0	USB-A	Typ D1	Punkt Dot Point
M.900.07.1	USB-A	Typ D1	Komma Comma Virgule



Bestell-Nr. Order no. Références	Schnittstelle PC Interface PC Interface PC	Schnittstelle Messmittel Interface measuring device Interface appareil de mesure	Daten Data Données
M.900.10.0	USB-A	EIA RS-453 / IEC 60603-11	Punkt Dot Point

Wireless
Sans fil



Bestell-Nr. Order no. Références	Daten Data Données	Funktion Function Fonction	Frequenz Frequency Fréquence	
M.901.00.4	Punkt Dot Point	Ausgang (Micro-USB-B) Output (Micro-USB-B) Sortie (Micro-USB-B)	2,4G	
M.901.00.3	Punkt Dot Point	Eingang (USB-A) Input (USB-A) Contribution (USB-A)	2,4G	

Batterien

Batteries
Batteries



Bestell-Nr. Order no. Références	Abmessung Size Dimension
M.CR2032	Batterie Battery Pile - 3 V CR2032
M.LR44	Batterie Battery Pile - 1,5 V LR44
M.B.MN21	Batterie Battery Pile - 12 V A23 / 23A / MN21
M.B.LR1	Batterie Battery Pile - 1,5 V LR1 / N / Lady

SCHNEIDWERKZEUGE
CUTTING TOOLS
OUTILS DE COUPANT

SCHNEIDWERKZEUGE

CUTTING TOOLS

OUTILS DE COUPANT

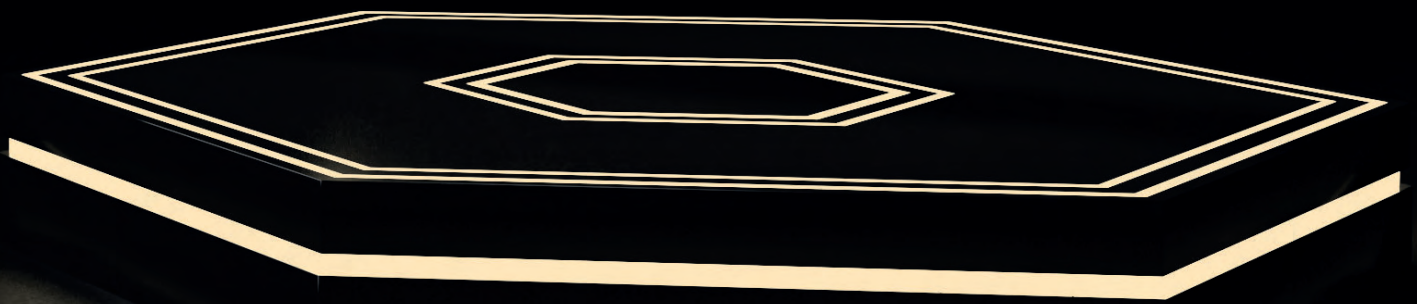
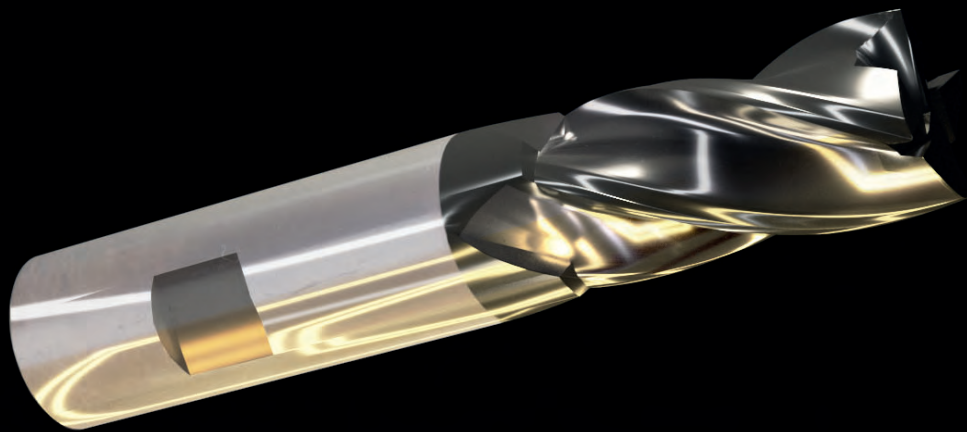

13.06-13.07



VHM Fräser 2 Schneiden
Solid carbide end mill 2 flutes
Fraise à queue en carbure monobloc 2 dents

13.08-13.09



VHM Fräser 3 Schneiden
Solid carbide end mill 3 flutes
Fraise à queue en carbure monobloc 3 dents

13.10-13.11



VHM Fräser 4 Schneiden
Solid carbide end mill 4 flutes
Fraise à queue en carbure monobloc 4 dents

13.08-13.09



VHM Stirnradiusfräser
2 Schneiden
Solid carbide ball nose end mill 2 flutes
Fraise à bout hémisphérique 2 dents

13.06-13.07



VHM Feinstkorn Schruppfräser
UMG Solid carbide roughing end mill
Fraise ébauche en carbure monobloc à micrograin

13.08-13.09



Vollhartmetall Zentrierbohrer 60°
Solid carbide center drill and countersink 60°
Foret à centrer en carbure monobloc 60°

13.16-13.17



Vollhartmetall NC Anbohrer
90°+120°
Solid carbide NC spot drill 90°+120°
Foret à centrer NC en carbure monobloc 90°+120°

13.41



HSSE - Kegelsenker 90°
HSSE - countersink 90°
HSSE - fraise à chanfreiner 90°

13.18-13.19



Alu Feinstkorn VHM Fräser
2+3 Schneiden
Alu UMG solid carbide end mill 2+3 flutes
Fraise alu à micrograin en carbure monobloc 2+3 dents

13.20



Alu Feinstkorn VHM Schruppfräser
3 Schneiden
Alu solid carbide roughing end mill 3 flutes
Fraise ébauche alu en carbure monobloc 3 dents

13.21



Alu VHM Stirnradiusfräser 2
Schneiden
Alu Solid carbide ball nose end mill 2 flutes
Fraise alu à bout hémisphérique en carbure monobloc 2 dents

13.28-13.31



HSS-E Gewindebohrer
Metrisches ISO-Gewinde
HSS-E spiral flute taps ISO metric coarse threads
Taraud HSS-E avec filetage métrique

13.32-13.37



HSS-E Gewindebohrer
Metrisches ISO-Feingewinde
HSS-E spiral flute taps ISO metric fine threads
Taraud HSS-E avec filetage métrique fin pour filetage

13.38-13.41



HSSE-Spiralbohrer DIN 338 - 130°
HSSE-twist DIN 338 drill - 130°
HSSE-forets DIN 338 - 130°

13.42-13.53



VHM Hochleistungsbohrer 3xD
Solid carbide high performance drills 3xD
Forets en carbure à haute performance 3xD

13.54-13.65



VHM Hochleistungsbohrer 5xD
Solid carbide high performance drills 5xD
Forets en carbure à haute performance 5xD

13.66-13.69



VHM Hochleistungsbohrer 8xD
Solid carbide high performance drills 8xD
Forets en carbure à haute performance 8xD

13.70-13.71



VHM NC Maschinenreibahlen H7 für Durchgangslöcher
Solid carbide NC machine reamers H7 for through holes
Carbure Alésoir NC machine H7 pour trou de passage

13.72-13.75



VHM NC Maschinenreibahlen für Sacklochbohrungen
Solid carbide NC machine reamers for blind holes
Carbure Alésoir NC machine filetage pour trou borgne

13.76-13.83



Eckfräser
Angular milling cutter
Fraise à coin

13.84-13.85

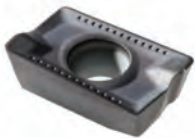

Wendeschneidplatten APKT und APHX
Inserts APKT and APHX
Plaquettes APKT et APHX

13.86-13.98



Bohrstangen SCLC + SDUC
Boring bars SCLC + SDUC
Barres d'alésage SCLC + SDUC



VHM Fräser 2 Schneiden kurz

Solid carbide end mill 2 flutes short

Fraise à queue en carbure monobloc 2 dents courte

Verwendung:

Beschichtung: AlTiCrN, Ausgezeichnete Hochleistungsfräser, zur Bearbeitung von Werkstoffen bis <48 HRC, Zylinderschaft nach DIN 6535 HB.

Application:

Coating: AlTiCrN, Excellent high-performance end mills, for processing material < 48HRC, for weldon shanks according to DIN 6535 HB.

Application:

Revêtement: AlTiCrN, fraises à coupe rapide, pour l'usage de matériau < 48HRC, queue cylindrique selon DIN 6535 HB.

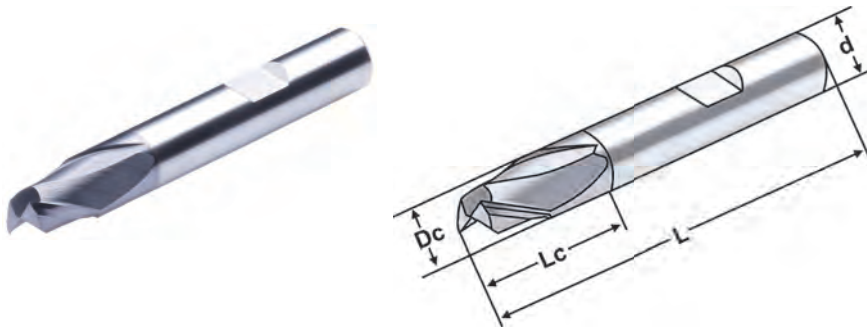

Bestell Nr. Order no. Référence	Dc h10	d h6	L mm	Lc mm
F500HX020	2	6	50	2
F500HX030	3	6	50	4
F500HX040	4	6	54	5
F500HX060	6	6	54	7
F500HX080	8	8	58	9
F500HX100	10	10	66	11
F500HX120	12	12	73	12
F500HX140	14	14	75	14
F500HX160	16	16	82	16
F500HX180	18	18	84	18
F500HX200	20	20	92	20

VHM Fräser Satz - 2 Schneiden kurz

Solid carbide end mill set 2 flutes short

Set de fraises à queue en carbure monobloc 2 dents courte



Bestell Nr. Order no. Référence	Abmessung Size Dimension
F500HX-S	(6tlg.) 3mm-4mm-6mm-8mm-10mm-12mm

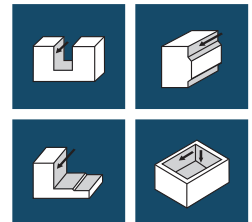
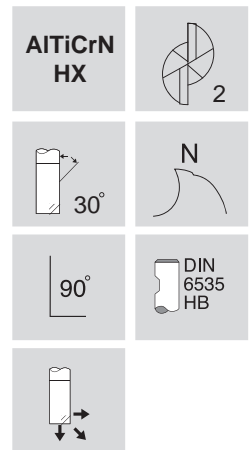

P	H	M	K	N	S
●	●	○	●	○	○

Nicht legierter Stahl
Non-alloyed steel
Acier non allié

Vc. 80-120

Wenig legierter Stahl
Low-alloyed steel
Acier faible allié

Vc. 80-120 < 24 HRC

Hoch legierter Stahl
High-alloyed steel
Acier fortement allié

Vc. 60-100 < 30HRC

Gehärteter Stahl
High-alloyed steel
Acier trempé

Vc. 40-80 30-38HRC

Hoch legierter Stahl
High-alloyed steel
Acier fortement allié

Vc. 30-60 38-60HRC

Edelstahl
Stainless Steel
Acier inoxydable

Vc. 40-60

Gusseisen
Cast Iron
Fonte

Vc. 100-140

Kupfer
Copper
Cuivre

Vc. 120-180

VHM Fräser 2 Schneiden lang



Solid carbide end mill 2 flutes long

Fraise à queue en carbure monobloc 2 dents longue

Verwendung:

Beschichtung: AlTiCrN, Ausgezeichnete Hochleistungsfräser, zur Bearbeitung von Werkstoffen bis <48 HRC, Zylinderschaft nach DIN 6535 HB.

Application:

Coating: AlTiCrN, Excellent high-performance end mills, for processing material < 48HRC, for weldon shanks according to DIN 6535 HB.

Application:

Revêtement: AlTiCrN, fraises à coupe rapide, pour l'usinage de matériau < 48HRC, queue cylindrique selon DIN 6535 HB.

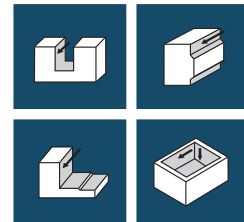
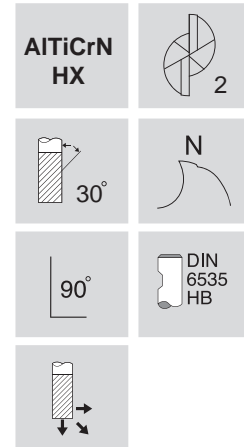
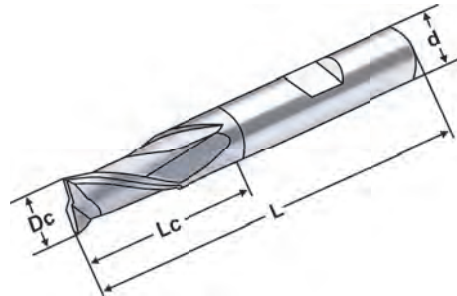

Bestell Nr. Order no. Référence	Dc h10	d h6	L mm	Lc mm
F501HX0300	3	6	57	7
F501HX0400	4	6	57	8
F501HX0600	6	6	57	10
F501HX0800	8	8	63	16
F501HX1000	10	10	72	19
F501HX1200	12	12	83	22
F501HX1400	14	14	83	22
F501HX1600	16	16	92	26
F501HX1800	18	18	92	26
F501HX2000	20	20	104	32

VHM Fräser Satz - 2 Schneiden lang

Solid carbide end mill set 2 flutes long

Set de fraises à queue en carbure monobloc 2 dents longue



Bestell Nr. Order no. Référence	Abmessung Size Dimension
F501HX-S	(6tlg.) 3mm-4mm-6mm-8mm-10mm-12mm

Schnittdaten Seite 13.22

Cutting data page 13.22

Données de coupe page 13.22

P	H	M	K	N	S
●	●	○	●	○	○

Nicht legierter Stahl
Non-alloyed steel
Acier non allié

Vc. 80-120

Wenig legierter Stahl
Low-alloyed steel
Acier faible allié

Vc. 80-120 < 24 HRC

Hoch legierter Stahl
High-alloyed steel
Acier fortement allié

Vc. 60-100 < 30HRC

Gehärteter Stahl
High-alloyed steel
Acier trempé

Vc. 40-80 30-38HRC

Hoch legierter Stahl
High-alloyed steel
Acier fortement allié

Vc. 30-60 38-60HRC

Edelstahl
Stainless Steel
Acier inoxydable

Vc. 40-60

Gusseisen
Cast Iron
Fonte

Vc. 100-140

Kupfer
Copper
Cuivre

Vc. 120-180



VHM Fräser 3 Schneiden kurz

Solid carbide end mill 3 flutes short

Fraise à queue en carbure monobloc 3 dents courte

Verwendung:

Beschichtung: AlTiCrN, Ausgezeichnete Hochleistungsfräser, zur Bearbeitung von Werkstoffen bis <48 HRC, Zylinderschaft nach DIN 6535 HB.

Application:

Coating: AlTiCrN, Excellent high-performance end mills, for processing material < 48HRC, for weldon shanks according to DIN 6535 HB.

Application:

Revêtement: AlTiCrN, fraises à coupe rapide, pour l'usinage de matériau < 48HRC, queue cylindrique selon DIN 6535 HB.

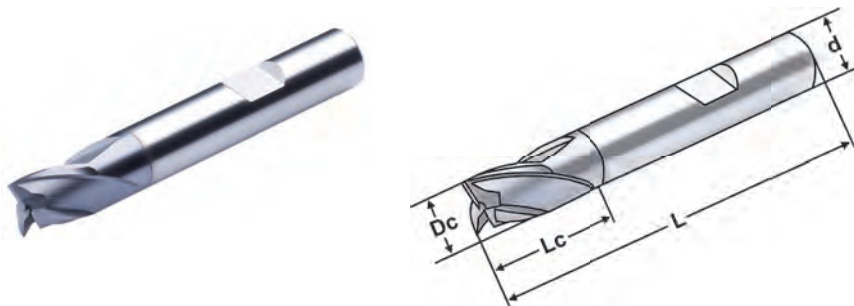

Bestell Nr. Order no. Référence	Dc h10	d h6	L mm	Lc mm
F503HX060	6	6	54	7
F503HX080	8	8	58	8
F503HX100	10	10	66	10
F503HX120	12	12	73	16
F503HX140	14	14	75	19
F503HX160	16	16	82	22
F503HX180	18	18	84	22
F503HX200	20	20	92	26

VHM Fräser Satz - 3 Schneiden kurz

Solid carbide end mill set 3 flutes short

Set de fraises à queue en carbure monobloc 3 dents courte



Bestell Nr. Order no. Référence	Abmessung Size Dimension
F503HX-S	(4tlg.) 6mm-8mm-10mm-12mm

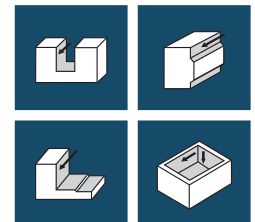
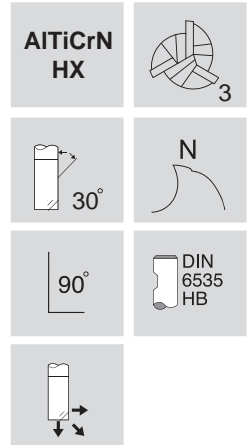

P	H	M	K	N	S
●	●	○	●	○	○

Nicht legierter Stahl
Non-alloyed steel
Acier non allié

Vc. 80-120

Wenig legierter Stahl
Low-alloyed steel
Acier faible allié

Vc. 80-120 < 24 HRC

Hoch legierter Stahl
High-alloyed steel
Acier fortement allié

Vc. 60-100 < 30HRC

Gehärteter Stahl
High-alloyed steel
Acier trempé

Vc. 40-80 30-38HRC

Hoch legierter Stahl
High-alloyed steel
Acier fortement allié

Vc. 30-60 38-60HRC

Edelstahl
Stainless Steel
Acier inoxydable

Vc. 40-60

Gusseisen
Cast Iron
Fonte

Vc. 100-140

Kupfer
Copper
Cuivre

Vc. 120-180

VHM Fräser 3 Schneiden lang



Solid carbide end mill 3 flutes long

Fraise à queue en carbure monobloc 3 dents longue

Verwendung:

Beschichtung: AlTiCrN, Ausgezeichnete Hochleistungsfräser, zur Bearbeitung von Werkstoffen bis <48 HRC, Zylinderschaft nach DIN 6535 HB.

Application:

Coating: AlTiCrN, Excellent high-performance end mills, for processing material < 48HRC, for weldon shanks according to DIN 6535 HB.

Application:

Revêtement: AlTiCrN, fraises à coupe rapide, pour l'usinage de matériau < 48HRC, queue cylindrique selon DIN 6535 HB.

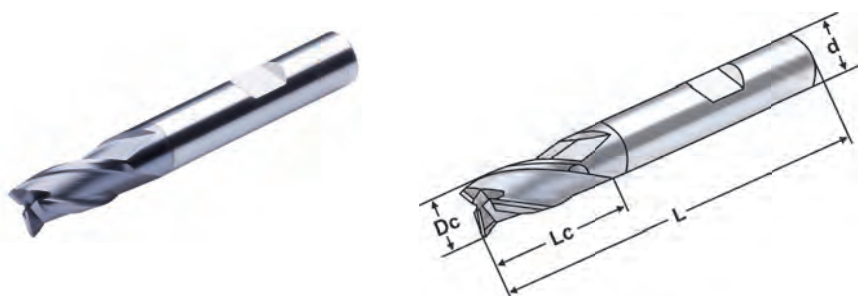

Bestell Nr. Order no. Référence	Dc h10	d h6	L mm	Lc mm
F504HX060	6	6	57	10
F504HX080	8	8	63	16
F504HX100	10	10	72	19
F504HX120	12	12	83	22
F504HX140	14	14	83	22
F504HX160	16	16	92	26
F504HX180	18	18	92	26
F504HX200	20	20	104	32

VHM Fräser Satz - 3 Schneiden lang

Solid carbide end mill set 3 flutes long

Set de fraises à queue en carbure monobloc 3 dents longue



Bestell Nr. Order no. Référence	Abmessung Size Dimension
F504HX-S	(4tlg.) 6mm-8mm-10mm-12mm

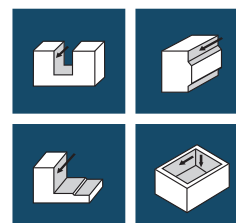
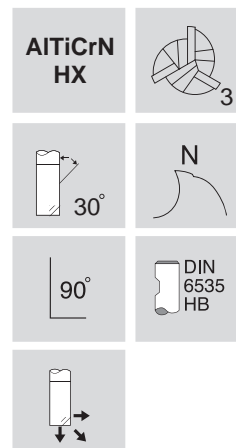

P	H	M	K	N	S
●	●	○	●	○	○

Nicht legierter Stahl
Non-alloyed steel
Acier non allié

Vc. 80-120

Wenig legierter Stahl
Low-alloyed steel
Acier faible allié

Vc. 80-120 < 24 HRC

Hoch legierter Stahl
High-alloyed steel
Acier fortement allié

Vc. 60-100 < 30HRC

Gehärteter Stahl
High-alloyed steel
Acier trempé

Vc. 40-80 30-38HRC

Hoch legierter Stahl
High-alloyed steel
Acier fortement allié

Vc. 30-60 38-60HRC

Edelstahl
Stainless Steel
Acier inoxydable

Vc. 40-60

Gusseisen
Cast Iron
Fonte

Vc. 100-140

Kupfer
Copper
Cuivre

Vc. 120-180

Schnittdaten Seite 13.23

Cutting data page 13.23

Données de coupe page 13.23



VHM Fräser 4 Schneiden kurz

Solid carbide end mill 4 flutes short

Fraise à queue en carbure monobloc 4 dents courte

Verwendung:

Beschichtung: AlTiCrN, Ausgezeichnete Hochleistungsfräser, zur Bearbeitung von Werkstoffen bis <48 HRC, Zylinderschaft nach DIN 6535 HB.

Application:

Coating: AlTiCrN, Excellent high-performance end mills, for processing material < 48HRC, for weldon shanks according to DIN 6535 HB.

Application:

Revêtement: AlTiCrN, fraises à coupe rapide, pour l'usinage de matériau < 48HRC, queue cylindrique selon DIN 6535 HB.

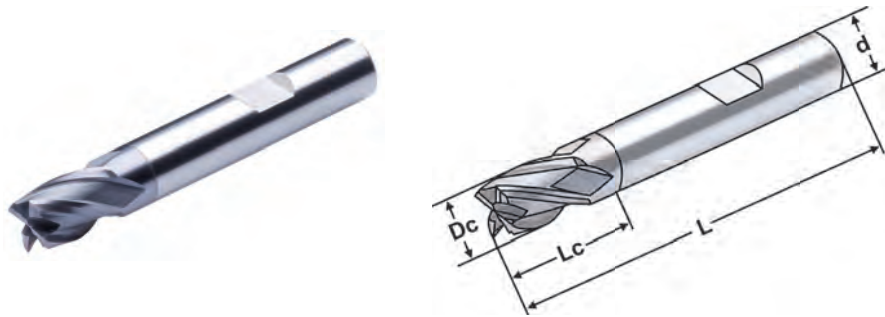

Bestell Nr. Order no. Référence	Dc h10	d h6	L mm	Lc mm
F506HX020	2	6	50	4
F506HX030	3	6	50	5
F506HX040	4	6	54	8
F506HX060	6	6	54	10
F506HX080	8	8	58	12
F506HX100	10	10	66	14
F506HX120	12	12	73	16
F506HX140	14	14	75	18
F506HX160	16	16	82	22
F506HX180	18	18	84	24
F506HX200	20	20	92	26

VHM Fräser Satz - 4 Schneiden kurz

Solid carbide end mill set 4 flutes short

Set de fraises à queue en carbure monobloc 4 dents courte



Bestell Nr. Order no. Référence	Abmessung Size Dimension
F506HX-S	(6tlg.) 3mm-4mm-6mm-8mm-10mm-12mm

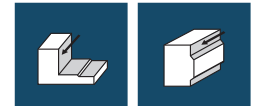
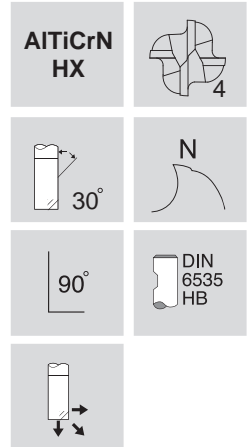

P	H	M	K	N	S
●	●	○	●	○	○

Nicht legierter Stahl
Non-alloyed steel
Acier non allié
Vc. 80-120

Wenig legierter Stahl
Low-alloyed steel
Acier faible allié
Vc. 80-120 < 24 HRC

Hoch legierter Stahl
High-alloyed steel
Acier fortement allié
Vc. 60-100 < 30HRC

Gehärteter Stahl
High-alloyed steel
Acier trempé
Vc. 40-80 30-38HRC

Hoch legierter Stahl
High-alloyed steel
Acier fortement allié
Vc. 30-60 38-60HRC

Edelstahl
Stainless Steel
Acier inoxydable
Vc. 40-60

Gusseisen
Cast Iron
Fonte
Vc. 100-140

Kupfer
Copper
Cuivre
Vc. 120-180

Schnittdaten Seite 13.23

Cutting data page 13.23

Données de coupe page 13.23

VHM Fräser 4 Schneiden lang



Solid carbide end mill 4 flutes long

Fraise à queue en carbure monobloc 4 dents longue

Verwendung:

Beschichtung: AlTiCrN, Ausgezeichnete Hochleistungsfräser, zur Bearbeitung von Werkstoffen bis <48 HRC, Zylinderschaft nach DIN 6535 HB.

Application:

Coating: AlTiCrN, Excellent high-performance end mills, for processing material < 48HRC, for weldon shanks according to DIN 6535 HB.

Application:

Revêtement: AlTiCrN, fraises à coupe rapide, pour l'usinage de matériau < 48HRC, queue cylindrique selon DIN 6535 HB.

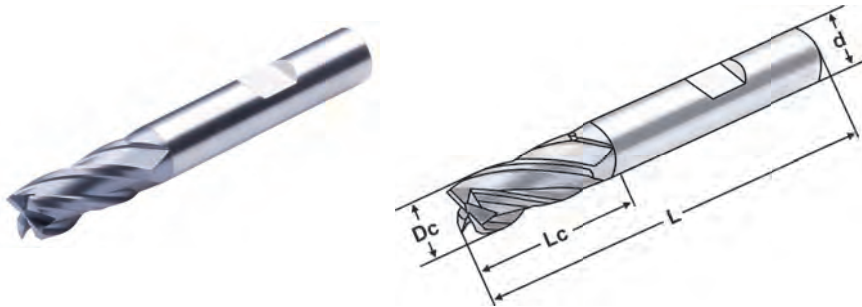

Bestell Nr. Order no. Référence	Dc h10	d h6	L mm	Lc mm
F507HX030	3	6	57	8
F507HX040	4	6	57	11
F507HX060	6	6	57	13
F507HX080	8	8	63	19
F507HX100	10	10	72	22
F507HX120	12	12	83	26
F507HX140	14	14	83	26
F507HX160	16	16	92	32
F507HX180	18	18	92	32
F507HX200	20	20	104	38

VHM Fräser Satz - 4 Schneiden lang

Solid carbide end mill set 4 flutes long

Set de fraises à queue en carbure monobloc 4 dents longue



Bestell Nr. Order no. Référence	Abmessung Size Dimension
F507HX-S	(6tlg.) 3mm-4mm-6mm-8mm-10mm-12mm

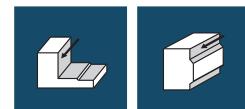
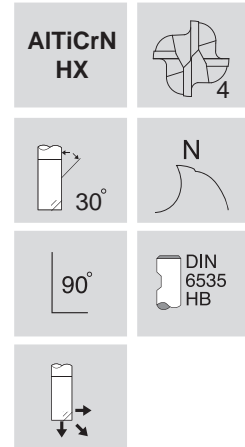

P	H	M	K	N	S
●	●	○	●	○	○

Nicht legierter Stahl
Non-alloyed steel
Acier non allié
Vc. 80-120

Wenig legierter Stahl
Low-alloyed steel
Acier faible allié
Vc. 80-120 < 24 HRC

Hoch legierter Stahl
High-alloyed steel
Acier fortement allié
Vc. 60-100 < 30HRC

Gehärteter Stahl
High-alloyed steel
Acier trempé
Vc. 40-80 30-38HRC

Hoch legierter Stahl
High-alloyed steel
Acier fortement allié
Vc. 30-60 38-60HRC

Edelstahl
Stainless Steel
Acier inoxydable
Vc. 40-60

Gusseisen
Cast Iron
Fonte
Vc. 100-140

Kupfer
Copper
Cuivre
Vc. 120-180

Schnittdaten Seite 13.23

Cutting data page 13.23

Données de coupe page 13.23



VHM Stirnradiusfräser 2 Schneiden kurz

Solid carbide ball nose end mill 2 flutes short
Fraise à bout hémisphérique 2 dents courte

Verwendung:

Beschichtung: AlTiCrN, Ausgezeichnete Hochleistungsfräser, zur Bearbeitung von Werkstoffen bis <48 HRC, Zylinderschaft nach DIN 6535 HB.

Application:

Coating: AlTiCrN, Excellent high-performance end mills, for processing material < 48HRC, for weldon shanks according to DIN 6535 HB.

Application:

Revêtement: AlTiCrN, fraises à coupe rapide, pour l'usinage de matériau < 48HRC, queue cylindrique selon DIN 6535 HB.

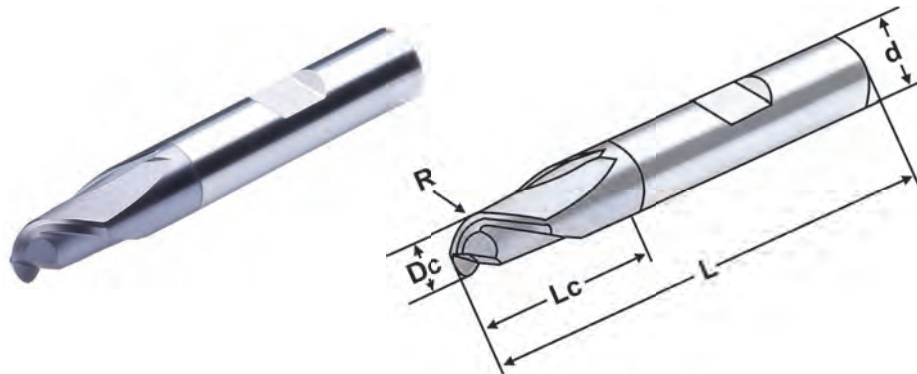

Bestell Nr. Order no. Référence	Dc h10	d h6	R ±0,01	L mm	Lc mm
F520HX020	2	6	R1,0	50	3
F520HX030	3	6	R1,5	50	4
F520HX040	4	6	R2,0	54	5
F520HX050	5	6	R2,5	54	6
F520HX060	6	6	R3,0	54	7
F520HX080	8	8	R4,0	58	9
F520HX100	10	10	R5,0	66	11
F520HX120	12	12	R6,0	73	12
F520HX140	14	14	R7,0	75	14
F520HX160	16	16	R8,0	82	16
F520HX180	18	18	R9,0	84	18
F520HX200	20	20	R10,0	92	20

VHM Stirnradiusfräser Satz - 2 Schneiden kurz

Solid carbide ball nose end mill set 2 flutes short
Set de fraises à bout hémisphérique 2 dents court



Bestell Nr. Order no. Référence	Abmessung Size Dimension
F520HX-S	(6tlg.) 3mm-4mm-6mm-8mm-10mm-12mm

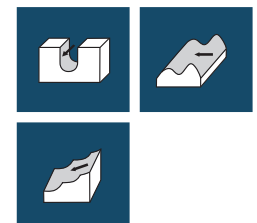
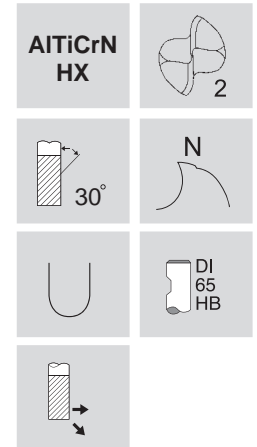

P	H	M	K	N	S
●	●	○	●	○	○

Nicht legierter Stahl
Non-alloyed steel
Acier non allié

Vc. 100-140

Wenig legierter Stahl
Low-alloyed steel
Acier faible allié

Vc. 100-140 < 24 HRC

Hoch legierter Stahl
High-alloyed steel
Acier fortement allié

Vc. 80-120 < 30HRC

Gehärteter Stahl
High-alloyed steel
Acier trempé

Vc. 70-100 30-38HRC

Hoch legierter Stahl
High-alloyed steel
Acier fortement allié

Vc. 50-80 38-60HRC

Edelstahl
Stainless Steel
Acier inoxydable

Vc. 60-90

Gusseisen
Cast Iron
Fonte

Vc. 120-160

Kupfer
Copper
Cuivre

Vc. 140-200

VHM Stirnradiusfräser 2 Schneiden lang



Solid carbide ball nose end mill 2 flutes long Fraise à bout hémisphérique 2 dents longue

Verwendung:

Beschichtung: AlTiCrN, Ausgezeichnete Hochleistungsfräser, zur Bearbeitung von Werkstoffen bis <48 HRC, Zylinderschaft nach DIN 6535 HB.

Application:

Coating: AlTiCrN, Excellent high-performance end mills, for processing material < 48HRC, for weldon shanks according to DIN 6535 HB.

Application:

Revêtement: AlTiCrN, fraises à coupe rapide, pour l'usinage de matériau < 48HRC, queue cylindrique selon DIN 6535 HB.

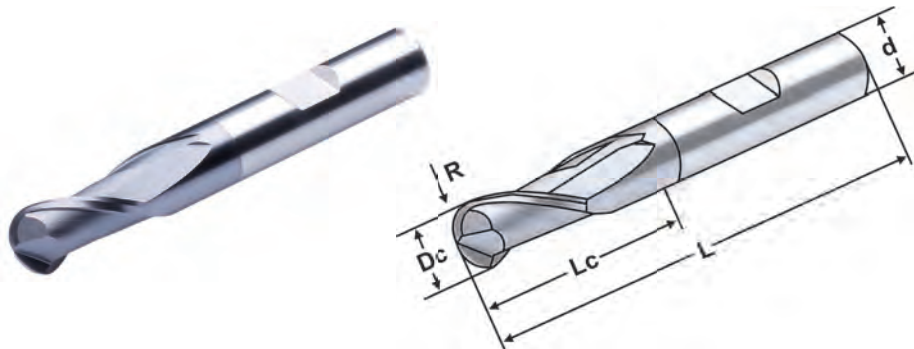

Bestell Nr. Order no. Référence	Dc h10	d h6	R ±0,01	L mm	Lc mm
F521HX020	2	6	R1,0	57	6
F521HX030	3	6	R1,5	57	7
F521HX040	4	6	R2,0	57	8
F521HX050	5	6	R2,5	57	10
F521HX060	6	6	R3,0	57	10
F521HX080	8	8	R4,0	63	16
F521HX100	10	10	R5,0	72	19
F521HX120	12	12	R6,0	83	22
F521HX140	14	14	R7,0	83	22
F521HX160	16	16	R8,0	92	26
F521HX180	18	18	R9,0	92	26
F521HX200	20	20	R10,0	104	32

VHM Stirnradiusfräser Satz - 2 Schneiden lang

Solid carbide ball nose end mill 2 flutes long Fraise à bout hémisphérique 2 dents longue



Bestell Nr. Order no. Référence	Abmessung Size Dimension
F521HX-S	(6tlg.) 3mm-4mm-6mm-8mm-10mm-12mm

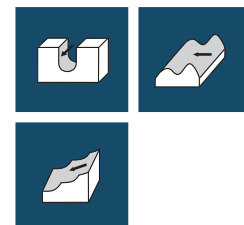
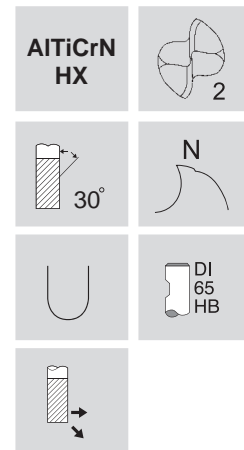

P	H	M	K	N	S
●	●	○	●	○	○

Nicht legierter Stahl
Non-alloyed steel
Acier non allié
Vc. 100-140

Wenig legierter Stahl
Low-alloyed steel
Acier faible allié
Vc. 100-140 < 24 HRC

Hoch legierter Stahl
High-alloyed steel
Acier fortement allié
Vc. 80-120 < 30HRC

Gehärteter Stahl
High-alloyed steel
Acier trempé
Vc. 70-100 30-38HRC

Hoch legierter Stahl
High-alloyed steel
Acier fortement allié
Vc. 50-80 38-60HRC

Edelstahl
Stainless Steel
Acier inoxydable
Vc. 60-90

Gusseisen
Cast Iron
Fonte
Vc. 120-160

Kupfer
Copper
Cuivre
Vc. 140-200

Schnittdaten Seite 13.24
Cutting data page 13.24
Données de coupe page 13.24

K VHM Feinstkorn Schruppfräser

UMG Solid carbide roughing end mill Fraise ébauche en carbure monobloc à micrograin

Verwendung:

Beschichtung: AlTiCrN, Ausgezeichnete Hochleistungsfräser, zur Bearbeitung von Werkstoffen bis <56 HRC, Zylinderschaft nach DIN 6535 HB.

Application:

Coating: AlTiCrN, Excellent high-performance end mills, for processing material < 56HRC, for weldon shanks according to DIN 6535 HB.

Application:

Revêtement: AlTiCrN, fraises à coupe rapide, pour l'usinage de matériau < 56HRC, queue cylindrique selon DIN 6535 HB.

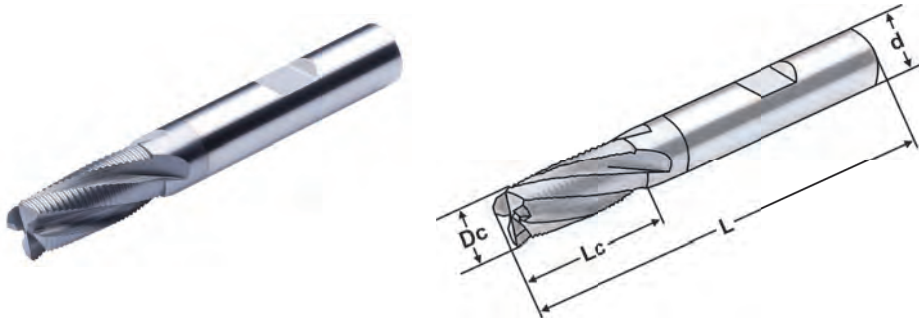

Bestell Nr. Order no. Référence	Dc h10	d h5	L mm	Lc mm	Z
F608HX.DC060	6	6	57	13	3
F608HX.DC080	8	8	63	19	3
F608HX.DC100	10	10	72	22	4
F608HX.DC120	12	12	83	26	4
F608HX.DC140	14	14	83	26	4
F608HX.DC160	16	16	92	32	4
F608HX.DC180	18	18	92	32	4
F608HX.DC200	20	20	104	38	4

VHM Feinstkorn Schruppfräser Satz

UMG Solid carbide roughing end mill set Set de fraises ébauche en carbure monobloc à micrograin



Bestell Nr. Order no. Référence	Abmessung Size Dimension
F608HX-S	(4tlg.) 6mm-8mm-10mm-12mm

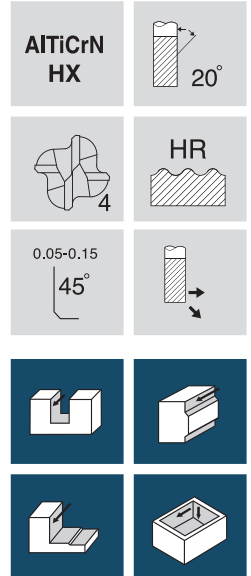

P	H	M	K	N	S
●	●	●	●	○	○

Nicht legierter Stahl
Non-alloyed steel
Acier non allié
Vc. 100-120

Wenig legierter Stahl
Low-alloyed steel
Acier faible allié
Vc. 100-120 < 24 HRC

Hoch legierter Stahl
High-alloyed steel
Acier fortement allié
Vc. 60-80 < 30HRC

Gehärteter Stahl
High-alloyed steel
Acier trempé
Vc. 40-60 30-38HRC

Hoch legierter Stahl
High-alloyed steel
Acier fortement allié
Vc. 30-40 38-60HRC

Hoch legierter Stahl
High-alloyed steel
Acier fortement allié
Vc. 60-90 48-56HRC

Gusseisen
Cast Iron
Fonte
Vc. 120-160

Titanium
Titanium
Titanium
Vc. 30-40

Vollhartmetall Zentrierbohrer 60°



Solid carbide center drill and countersink 60°
Foret à centrer en carbure monobloc 60°

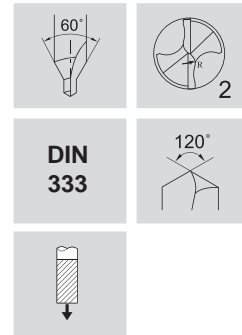
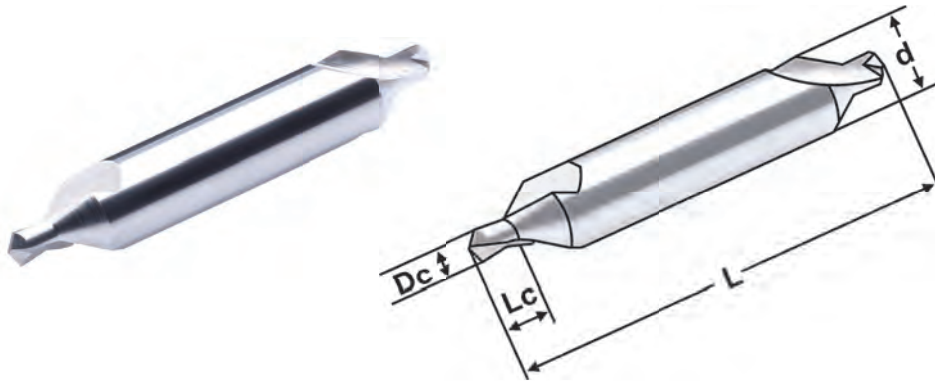

Bestell Nr. Order no. Référence	Dc h10	d h6	L mm	Lc mm
D908.DC0.50	0,50	3	38	0,8
D908.DC0.80	0,80	3	38	1,1
D908.DC1.00	1,00	3	38	1,3
D908.DC1.25	1,25	3	38	1,6
D908.DC1.60	1,60	4	38	2,0
D908.DC2.00	2,00	5	50	2,5
D908.DC2.50	2,50	6	50	3,1
D908.DC3.15	3,15	8	63	3,9
D908.DC4.00	4,00	10	66	5,0
D908.DC5.00	5,00	12	73	6,3

P	H	M	K	N	S
●	●	○	●	○	○

Nicht legierter Stahl
Non-alloyed steel
Acier non allié
Vc. 30-40

Wenig legierter Stahl
Low-alloyed steel
Acier faible allié
Vc. 30-40 < 24 HRC

Hoch legierter Stahl
High-alloyed steel
Acier fortement allié
Vc. 20-30 < 30HRC

Gehärteter Stahl
High-alloyed steel
Acier trempé
Vc. 10-20 30-38HRC

Hoch legierter Stahl
High-alloyed steel
Acier fortement allié
Vc. 10-20 38-60HRC

Edelstahl
Stainless Steel
Acier inoxydable
Vc. 15-25

Gusseisen
Cast Iron
Fonte
Vc. 40-50

Aluminium
Aluminium
Aluminium
Vc. 80-100

Kupfer
Copper
Cuivre
Vc. 60-80

Schnittdaten Seite 13.25
Cutting data page 13.25
Données de coupe page 13.25



Vollhartmetall NC Anbohrer 90°

Solid carbide NC spot drill 90°
Foret à centrer NC en carbure monobloc 90°

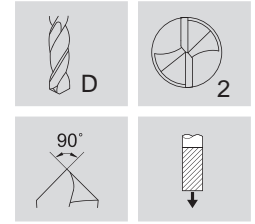
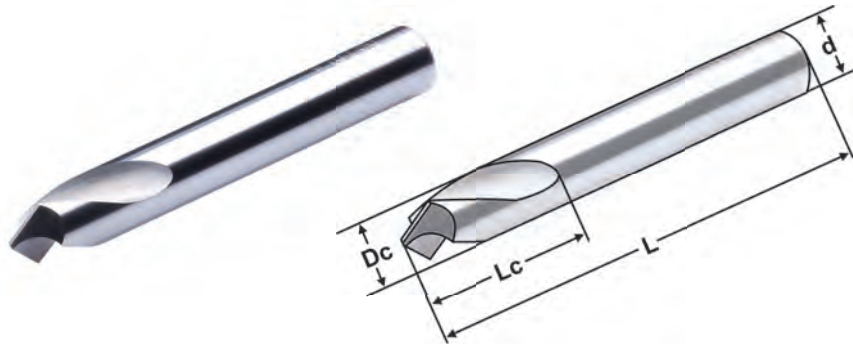

Bestell Nr. Order no. Référence	Dc h6	d h6	L mm	Lc mm
D903.DC040	4	4	50	12
D903.DC060	6	6	60	20
D903.DC080	8	8	60	25
D903.DC100	10	10	72	25
D903.DC120	12	12	75	30
D903.DC160	16	16	100	35
D903.DC200	20	20	100	40

P	H	M	K	N	S
●	●	○	●	○	○

Nicht legierter Stahl
Non-alloyed steel
Acier non allié
Vc. 50-60

Wenig legierter Stahl
Low-alloyed steel
Acier faible allié
Vc. 50-60 < 24 HRC

Hoch legierter Stahl
High-alloyed steel
Acier fortement allié
Vc. 40-50 < 30HRC

Gehärteter Stahl
High-alloyed steel
Acier trempé
Vc. 40-50 30-38HRC

Hoch legierter Stahl
High-alloyed steel
Acier fortement allié
Vc. 30-40 38-60HRC

Edelstahl
Stainless Steel
Acier inoxydable
Vc. 20-30

Gusseisen
Cast Iron
Fonte
Vc. 60-70

Kupfer
Copper
Cuivre
Vc. 80-100

Titanium
Titanium
Titanium
Vc. 80-100

Nickel
Nickel
Nickel
Vc. 15-20



Vollhartmetall NC Anbohrer Satz 90°

Solid carbide NC spot drill set 90°
Set de forets à centrer NC en carbure monobloc 90°

Bestell Nr. Order no. Référence	Abmessung Size Dimension
D903-S	(5tlg.) 4mm-6mm-8mm-10mm-12mm

Vollhartmetall NC Anbohrer 120°



Solid carbide NC spot drill 120°

Foret à centrer NC en carbure monobloc 120°

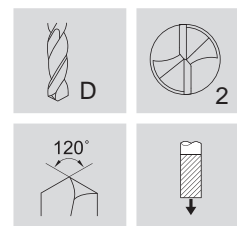
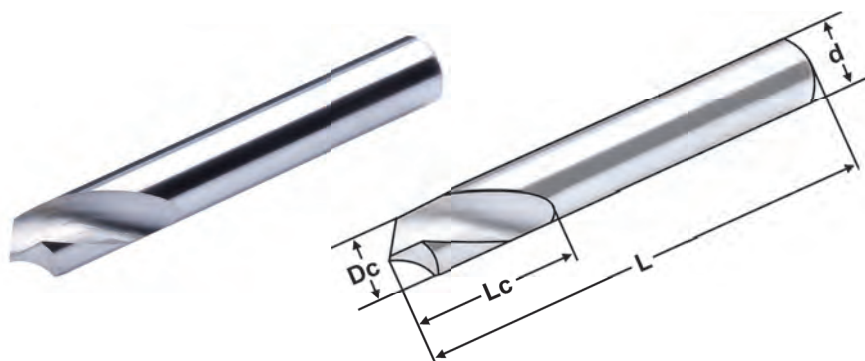

Bestell Nr. Order no. Référence	Dc h6	d h6	L mm	Lc mm
D913.DC040	4	4	50	12
D913.DC060	6	6	60	20
D913.DC080	8	8	60	25
D913.DC100	10	10	72	25
D913.DC120	12	12	75	30
D913.DC160	16	16	100	35
D913.DC200	20	20	100	40

Vollhartmetall NC Anbohrer Satz 120°

Solid carbide NC spot drill set 120°

Set de forets à centrer NC en carbure monobloc 120°



Bestell Nr. Order no. Référence	Abmessung Size Dimension
D913-S	(5tlg.) 4mm-6mm-8mm-10mm-12mm

P	H	M	K	N	S
●	●	○	●	○	○

Nicht legierter Stahl
Non-alloyed steel
Acier non allié
Vc. 50-60

Wenig legierter Stahl
Low-alloyed steel
Acier faible allié
Vc. 50-60 < 24 HRC

Hoch legierter Stahl
High-alloyed steel
Acier fortement allié
Vc. 40-50 < 30HRC

Gehärteter Stahl
High-alloyed steel
Acier trempé
Vc. 40-50 30-38HRC

Hoch legierter Stahl
High-alloyed steel
Acier fortement allié
Vc. 30-40 38-60HRC

Edelstahl
Stainless Steel
Acier inoxydable
Vc. 20-30

Gusseisen
Cast Iron
Fonte
Vc. 60-70

Kupfer
Copper
Cuivre
Vc. 80-100

Titanium
Titanium
Titanium
Vc. 80-100

Nickel
Nickel
Nickel
Vc. 15-20

Schnittdaten Seite 13.25

Cutting data page 13.25

Données de coupe page 13.25



Aluminium Feinstkorn VHM Fräser 2 Schneiden

Aluminium UMG solid carbide end mill 2 flutes

Fraise aluminium à micrograin en carbure monobloc 2 dents

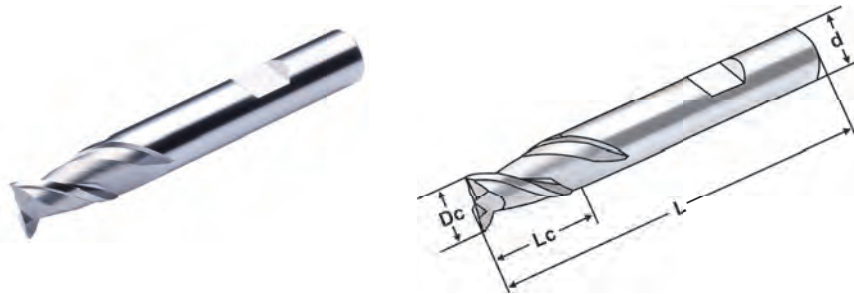
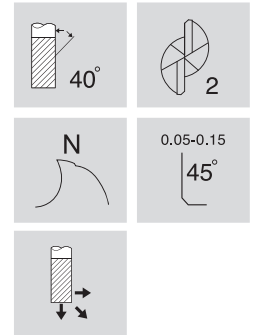

Bestell Nr. Order no. Référence	Dc h10	d h5	L mm	Lc mm
F600.DC030	3	6	57	7
F600.DC040	4	6	57	8
F600.DC050	5	6	57	10
F600.DC060	6	6	57	10
F600.DC080	8	8	63	16
F600.DC100	10	10	72	19
F600.DC120	12	12	83	22

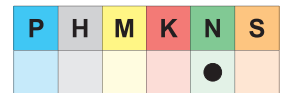
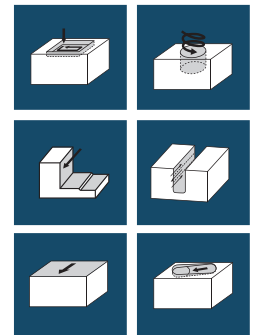

Aluminium
Aluminium
Aluminium
Vc. 80-100

Kupfer
Copper
Cuivre
Vc. 60-80

Aluminium Feinstkorn VHM Fräser Satz - 2 Schneiden

Aluminium UMG solid carbide end mill set 2 flutes

Set de fraises aluminium à micrograin en carbure monobloc 2 dents

Bestell Nr. Order no. Référence	Abmessung Size Dimension
F600.DC-S	(6tlg.) 3mm-4mm-6mm-8mm-10mm-12mm



Aluminium Feinstkorn VHM Fräser 3 Schneiden



Aluminium UMG solid carbide end mill 3 flutes

Fraise aluminium à micrograin en carbure monobloc 3 dents

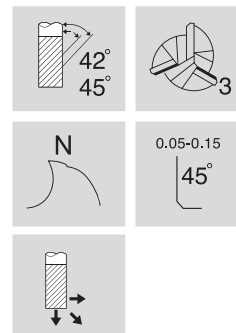

Bestell Nr. Order no. Référence	Dc h10	d h5	L mm	Lc mm
F631.DC030	3	6	57	8
F631.DC040	4	6	57	11
F631.DC050	5	6	57	13
F631.DC060	6	6	57	13
F631.DC080	8	8	63	19
F631.DC100	10	10	72	22
F631.DC120	12	12	83	26

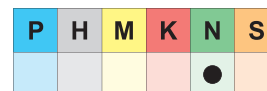
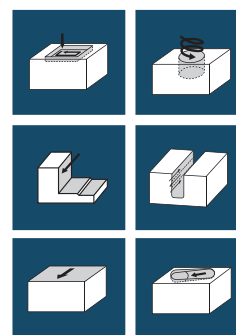

Aluminium
Aluminium
Aluminium
Vc. 80-100

Kupfer
Copper
Cuivre
Vc. 60-80

Aluminium Feinstkorn VHM Fräser Satz - 3 Schneiden

Aluminium UMG solid carbide end mill set 3 flutes

Set de fraises aluminium à micrograin en carbure monobloc 3 dents

Bestell Nr. Order no. Référence	Abmessung Size Dimension
F631.DC-S	(6tlg.) 3mm-4mm-6mm-8mm-10mm-12mm



Schnittdaten Seite 13.26

Cutting data page 13.26

Données de coupe page 13.26



Aluminium Feinstkorn VHM Schrappfräser 3 Schneiden

Aluminium UMG solid carbide roughing end mill 3 flutes

Fraise ébauche aluminium à micrograin en carbure monobloc 3 dents

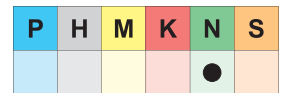
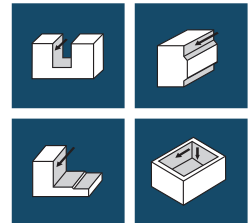
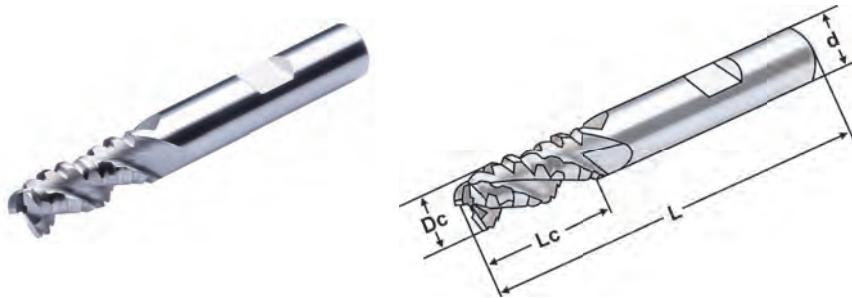
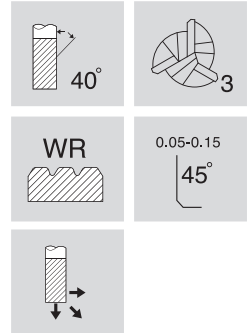

Bestell Nr. Order no. Référence	Dc h10	d h5	L mm	Lc mm
F642.DC060	6	6	57	13
F642.DC080	8	8	63	19
F642.DC100	10	10	72	22
F642.DC120	12	12	83	26
F642.DC160	16	16	92	32
F642.DC200	20	20	104	38

Aluminium
Aluminium
Aluminium
Vc. 80-100

Kupfer
Copper
Cuivre
Vc. 60-80

Aluminium Feinstkorn VHM Schrappfräser Satz 3 Schneiden

Aluminium UMG solid carbide roughing end mill set 3 flutes

Set de fraises ébauche aluminium à micrograin en carbure monobloc 3 dents

Bestell Nr. Order no. Référence	Abmessung Size Dimension
F642.DC-S	(4tlg.) 6mm-8mm-10mm-12mm



Aluminium Feinstkorn VHM Stirnradiusfräser 2 Schneiden



Aluminium UMG Solid carbide ball nose end mill 2 flutes

Fraise aluminium à bout hémisphérique en carbure monobloc 2 dents

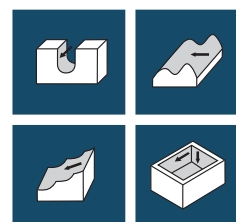
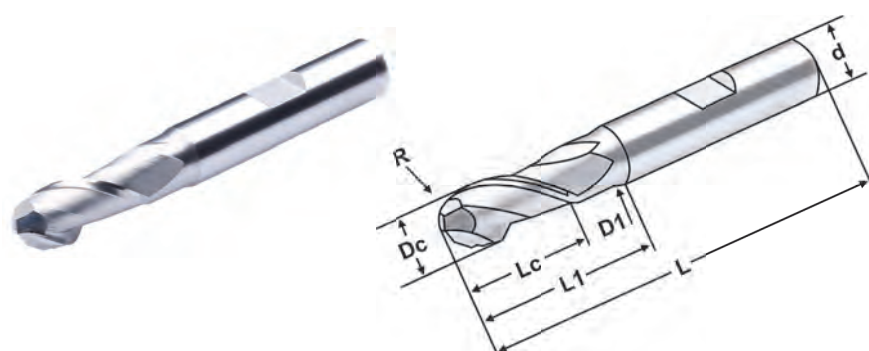
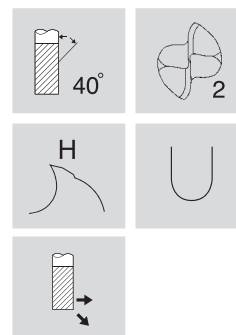

P	H	M	K	N	S
				●	

Aluminium Aluminium Aluminium
Vc. 80-100

Kupfer Copper Cuivre
Vc. 60-80

Bestell Nr. Order no. Référence	Dc h10	d h5	R ±0,01	L mm	Lc mm	L1 mm	D1 mm
F618.DC030	3	6	R1,5	57	6	9	2,8
F618.DC040	4	6	R2,0	57	8	12	3,7
F618.DC050	5	6	R2,5	57	10	15	4,6
F618.DC060	6	6	R3,0	57	12	20	5,5
F618.DC080	8	8	R4,0	63	16	26	7,4
F618.DC100	10	10	R5,0	72	20	31	9,2
F618.DC120	12	12	R6,0	83	24	37	11,0

Aluminium Feinstkorn VHM Stirnradiusfräser Satz - 2 Schneiden

Aluminium UMG Solid carbide ball nose end mill set 2 flutes

Set de fraises aluminium à bout hémisphérique en carbure monobloc 2 dents

Bestell Nr. Order no. Référence	Abmessung Size Dimension
F618.DC-S	(6tlg.) 3mm-4mm-6mm-8mm-10mm-12mm



Schnittdaten Seite 13.27
Cutting data page 13.27
Données de coupe page 13.27

Materialgruppen Material groups Groupes matières	N/mm²	HB	0.1	0.2	0.3	0.4	0.6	0.8	0.10	0.12	0.16	0.20
P Nicht legierter Stahl Non-alloyed steel Acier non allié	≤ 700	≤ 210	0,005-0,006	0,01-0,016	0,014-0,017	0,022-0,026	0,028-0,033	0,037-0,045	0,048-0,058	0,063-0,075	0,082-0,087	0,1-0,013
	700-1000	210-300	0,005-0,006	0,01-0,016	0,014-0,017	0,022-0,026	0,028-0,033	0,037-0,045	0,048-0,058	0,063-0,075	0,082-0,087	0,1-0,013
	>1000	>300	0,00-0,005	0,007-0,009	0,011-0,014	0,016-0,02	0,021-0,027	0,028-0,035	0,035-0,045	0,048-0,058	0,065-0,075	0,08-0,01
H Stahl 30-38HRC Steel 30-38HRC Acier 30-38HRC			0,00-0,005	0,007-0,009	0,011-0,014	0,016-0,02	0,021-0,027	0,028-0,035	0,035-0,045	0,048-0,058	0,065-0,075	0,08-0,01
			0,003	0,005	0,007	0,01	0,014	0,019	0,025	0,032	0,042	0,05
			0,002	0,003	0,005	0,007	0,009	0,12	0,016	0,02	0,03	0,04
M Edelstahl Stainless Steel Acier inoxydable	500-950	250-320	0,003-0,005	0,007-0,01	0,01-0,014	0,014-0,021	0,019-0,028	0,026-0,037	0,033-0,048	0,043-0,063	0,055-0,082	0,08-0,11
			0,001	0,002	0,004	0,005	0,007	0,009	0,012	0,016	0,02	0,03
			0,003-0,005	0,007-0,01	0,01-0,014	0,014-0,021	0,019-0,028	0,026-0,037	0,033-0,048	0,043-0,063	0,055-0,082	0,08-0,11
K Gusseisen Cast Iron Fonte		180-280	0,004-0,006	0,008-0,011	0,012-0,017	0,017-0,025	0,022-0,033	0,03-0,045	0,039-0,058	0,051-0,075	0,067-0,097	0,09-0,13
N Aluminium Aluminium Aluminium Kupfer Copper Cuivre Plastik Plastic Plastique Gusswerkstoffe Composite material Matériaux de moulage Graphit Graphite Graphite		Si 0,5-12%	0,004-0,006	0,008-0,011	0,013-0,016	0,018-0,023	0,025-0,032	0,035-0,045	0,042-0,055	0,055-0,071	0,072-0,092	0,09-0,12
		180-250	0,003-0,006	0,006-0,011	0,009-0,016	0,014-0,023	0,018-0,031	0,025-0,042	0,032-0,055	0,041-0,071	0,055-0,092	0,07-0,12
			0,005	0,01	0,015	0,022	0,029	0,04	0,052	0,068	0,087	0,11
S Titanium Titanium Titanium Nickel Nickel Nickel Hitzebeständiger Stahl Heat resistant steel Acier thermorésistant			0,005	0,01	0,015	0,022	0,029	0,04	0,052	0,068	0,087	0,11
			0,005-0,007	0,006-0,009	0,009-0,013	0,014-0,021	0,032-0,04	0,048-0,07	0,072-0,11	0,087-0,13	0,11-0,16	0,14-0,21
		700-1250	0,003-0,005	0,006-0,01	0,009-0,015	0,013-0,022	0,017-0,029	0,023-0,04	0,03-0,051	0,039-0,067	0,051-0,087	0,07-0,012
	900-1200	260-350	0,003-0,004	0,005-0,008	0,008-0,013	0,012-0,018	0,016-0,024	0,021-0,033	0,027-0,042	0,035-0,055	0,046-0,072	0,06-0,09
	900-1400	210-400	0,003-0,004	0,007-0,008	0,01-0,013	0,014-0,018	0,019-0,024	0,026-0,033	0,033-0,042	0,043-0,055	0,056-0,072	0,08-0,1



Solid carbide end mill 3+4 flutes
Fraise à queue en carbure monobloc 3+4 dents

Materialgruppen Material groups Groupes matières	N/mm²	HB	Ø 1	Ø 2	Ø 3	Ø 4	Ø 6	Ø 8	Ø 10	Ø 12	Ø 16	Ø 20
P Nicht legierter Stahl Non-alloyed steel Acier non allié	≤ 700	≤ 210	0,006-0,008	0,011-0,013	0,016-0,019	0,023-0,028	0,03-0,04	0,045-0,055	0,055-0,065	0,075-0,085	0,08-0,09	0,12-0,014
	700-1000	210-300	0,006-0,008	0,011-0,013	0,016-0,019	0,023-0,028	0,03-0,04	0,045-0,055	0,055-0,065	0,075-0,085	0,08-0,09	0,12-0,014
	> 1000	> 300	0,005-0,007	0,009-0,011	0,014-0,017	0,022-0,026	0,026-0,037	0,037-0,052	0,05-0,06	0,07-0,08	0,07-0,08	0,1-0,12
H Stahl 30-38HRC Steel 30-38HRC Acier 30-38HRC Stahl 38-48 HRC Steel 38-48 HRC Acier 38-48 HRC Stahl 48-56 HRC Steel 48-56 HRC Acier 48-56 HRC Stahl 56-68 HRC Steel 56-68 HRC Acier 56-68 HRC	500-950	250-320	0,005-0,01	0,01-0,015	0,013-0,017	0,017-0,024	0,022-0,032	0,03-0,04	0,04-0,05	0,047-0,055	0,05-0,06	0,08-0,13
		180-280	0,006-0,009	0,011-0,016	0,017-0,022	0,022-0,03	0,029-0,036	0,037-0,055	0,052-0,063	0,06-0,08	0,07-0,09	0,12-0,15
		Si 0,5-12%	0,006-0,009	0,012-0,03	0,018-0,025	0,023-0,033	0,03-0,04	0,04-0,06	0,06-0,07	0,062-0,083	0,08-0,11	0,13-0,2
		180-250	0,005-0,009	0,001-0,03	0,015-0,024	0,02-0,03	0,025-0,035	0,03-0,05	0,04-0,06	0,055-0,075	0,06-0,08	0,07-0,18
N Plastik Plastic Plastique Gusswerkstoffe Composite material Matériaux de moulage			0,007	0,012	0,017	0,025	0,032	0,045	0,06	0,07	0,095	0,13
			0,007	0,012	0,017	0,025	0,032	0,045	0,06	0,07	0,095	0,13
S Titanium Titanium Titanium Nickel Nickel/ Nickel Hitzebeständiger Stahl Heat resistant steel Acier thermorésistant	700-1250	210-370	0,005-0,007	0,008-0,013	0,012-0,017	0,015-0,025	0,02-0,032	0,03-0,045	0,038-0,05	0,045-0,07	0,065-0,094	0,08-0,13
	900-1200	260-350	0,004-0,006	0,007-0,01	0,01-0,015	0,014-0,022	0,018-0,028	0,025-0,04	0,03-0,045	0,04-0,06	0,06-0,08	0,07-0,1
	900-1400	210-400	0,005-0,065	0,008-0,011	0,011-0,016	0,015-0,024	0,02-0,03	0,03-0,044	0,033-0,048	0,04-0,065	0,063-0,09	0,1-0,12

Materialgruppen Material groups Groupes matières	N/mm ²	HB	Ø 1	Ø 2	Ø 3	Ø 4	Ø 6	Ø 8	Ø 10	Ø 12	Ø 16	Ø 20
P Nicht legierter Stahl Non-alloyed steel Acier non allié	≤ 700	≤ 210	0,01-0,012	0,02-0,022	0,026-0,03	0,037-0,041	0,062-0,066	0,1-0,11	0,11-0,126	0,12-0,14	0,16-0,18	0,18-0,2
	700-1000	210-300	0,01-0,012	0,02-0,022	0,026-0,03	0,037-0,041	0,062-0,066	0,1-0,11	0,11-0,126	0,12-0,14	0,16-0,18	0,18-0,2
	>1000	>300	0,008-0,01	0,018-0,02	0,026-0,028	0,035-0,039	0,059-0,063	0,08-0,09	0,09-0,011	0,1-0,12	0,14-0,16	0,16-0,18
H Stahl 30-38HRC Steel 30-38HRC Acier 30-38HRC			0,008-0,01	0,018-0,02	0,026-0,028	0,035-0,039	0,059-0,063	0,08-0,09	0,09-0,011	0,1-0,12	0,14-0,16	0,16-0,18
			0,005-0,008	0,009-0,012	0,015-0,019	0,03-0,034	0,048-0,052	0,079-0,083	0,094-0,098	0,09-0,116	0,12-0,14	0,14-0,16
			0,006	0,01	0,016	0,028	0,046	0,07	0,088	0,1	0,12	0,13
M Edelstahl Stainless Steel Acier inoxydable	500-950	250-320	0,005-0,008	0,009-0,012	0,015-0,019	0,03-0,034	0,048-0,052	0,079-0,083	0,094-0,098	0,09-0,116	0,12-0,14	0,14-0,16
			0,01-0,012	0,02-0,022	0,026-0,03	0,037-0,041	0,062-0,066	0,1-0,11	0,11-0,126	0,12-0,14	0,16-0,18	0,18-0,2
			0,012-0,014	0,02-0,024	0,03-0,036	0,044-0,048	0,07-0,075	0,11-0,13	0,12-0,14	0,14-0,16	0,18-0,2	0,2-0,22
K Gusseisen Cast Iron Fonte		180-280	0,01-0,012	0,02-0,022	0,026-0,03	0,037-0,041	0,062-0,066	0,1-0,11	0,11-0,126	0,12-0,14	0,16-0,18	0,18-0,2
			0,01-0,012	0,018-0,022	0,028-0,032	0,04-0,044	0,065-0,07	0,1-0,12	0,11-0,13	0,12-0,14	0,16-0,18	0,18-0,2
			0,015-0,023	0,03-0,037	0,05-0,065	0,06-0,075	0,09-0,12	0,13-0,17	0,16-0,2	0,2-0,3	0,25-0,4	0,3-0,5
N Plastik Plastic Plastique		180-250	0,01-0,012	0,018-0,022	0,028-0,032	0,04-0,044	0,065-0,07	0,1-0,12	0,11-0,13	0,12-0,14	0,16-0,18	0,18-0,2
			0,015-0,023	0,03-0,037	0,05-0,065	0,06-0,075	0,09-0,12	0,13-0,17	0,16-0,2	0,2-0,3	0,25-0,4	0,3-0,5
			0,015-0,023	0,03-0,037	0,05-0,065	0,06-0,075	0,09-0,12	0,13-0,17	0,16-0,2	0,2-0,3	0,25-0,4	0,3-0,5
S Gusswerkstoffe Composite material Matériaux de moulage			0,02-0,025	0,03-0,04	0,05-0,06	0,05-0,06	0,08-0,09	0,1-0,12	0,12-0,15	0,14-0,18	0,18-0,22	0,2-0,24
			0,005-0,008	0,009-0,012	0,015-0,019	0,03-0,034	0,048-0,052	0,079-0,083	0,094-0,098	0,09-0,116	0,12-0,14	0,14-0,16
			0,006-0,008	0,008-0,01	0,012-0,014	0,025-0,028	0,044-0,048	0,07-0,075	0,08-0,085	0,08-0,1	0,1-0,12	0,11-0,13
Hitzebeständiger Stahl Heat resistant steel Acier thermorésistant	900-1400	210-400	0,006-0,008	0,008-0,01	0,012-0,014	0,025-0,028	0,044-0,048	0,07-0,075	0,08-0,085	0,08-0,1	0,1-0,12	0,11-0,13
			0,006-0,008	0,008-0,01	0,012-0,014	0,025-0,028	0,044-0,048	0,07-0,075	0,08-0,085	0,08-0,1	0,1-0,12	0,11-0,13
			0,006-0,008	0,008-0,01	0,012-0,014	0,025-0,028	0,044-0,048	0,07-0,075	0,08-0,085	0,08-0,1	0,1-0,12	0,11-0,13

Vollhartmetall NC Anbohrer 90°+120°

Solid carbide NC spot drill 90° +120°
Foret à centrer NC en carbure monobloc 90°+120°

Vollhartmetall Zentrierbohrer 60°

Solid carbide center drill and countersink 60°
Foret à centreren carbure monobloc 60°



Materialgruppen Material groups Groupes matières	N/mm ²	HB	Ø 1	Ø 2	Ø 3	Ø 4	Ø 6	Ø 8	Ø 10	Ø 12	Ø 16	Ø 20
P Nicht legierter Stahl Non-alloyed steel Acier non allié	≤ 700	≤ 210	0,015-0,02	0,02-0,03	0,03-0,05	0,045-0,07	0,065-0,1	0,085-0,125	0,1-0,155	0,13-0,19	0,13-0,24	0,15-0,25
	700-1000	210-300	0,015-0,02	0,02-0,03	0,03-0,05	0,045-0,07	0,065-0,1	0,085-0,125	0,1-0,155	0,13-0,19	0,13-0,24	0,15-0,25
	> 1000	> 300	0,01-0,016	0,016-0,02	0,025-0,03	0,035-0,045	0,05-0,06	0,065-0,08	0,08-0,1	0,1-0,12	0,12-0,15	0,14-0,2
H Stahl 30-38HRC Steel 30-38HRC Acier 30-38HRC			0,01-0,016	0,016-0,02	0,025-0,03	0,035-0,045	0,05-0,06	0,065-0,08	0,08-0,1	0,1-0,12	0,12-0,15	0,14-0,2
			0,005	0,01	0,015	0,022	0,031	0,04	0,05	0,06	0,075	0,09
M Edelstahl Stainless Steel Acier inoxydable	500-950	250-320	0,01-0,015	0,016-0,023	0,025-0,023	0,025-0,035	0,035-0,05	0,05-0,07	0,08-0,12	0,1-0,14	0,12-0,175	0,135-0,2
		180-280	0,013-0,02	0,023-0,037	0,034-0,055	0,05-0,08	0,07-0,11	0,09-0,145	0,11-0,18	0,135-0,22	0,17-0,27	0,19-0,32
K Gusseisen Cast Iron Fonte			0,015-0,025	0,03-0,051	0,045-0,076	0,066-0,11	0,092-0,154	0,12-0,2	0,15-0,25	0,18-0,3	0,225-0,375	0,25-0,4
		Si 0,5-12%										
		180-250	0,012-0,03	0,022-0,04	0,03-0,06	0,05-0,08	0,06-0,14	0,08-0,17	0,11-0,2	0,12-0,25	0,15-0,27	0,2-0,3
N Plastik Plastic Plastique			0,01-0,02	0,02-0,024	0,03-0,036	0,044-0,052	0,062-0,073	0,08-0,095	0,1-0,12	0,12-0,15	0,15-0,18	0,16-0,2
			0,015-0,02	0,023-0,027	0,034-0,04	0,049-0,058	0,069-0,081	0,09-0,105	0,11-0,13	0,13-0,158	0,17-0,2	0,2-0,25
S Titanium Titanium Titanium	700-1250	210-370	0,01-0,016	0,02-0,029	0,03-0,044	0,044-0,063	0,062-0,088	0,08-0,115	0,1-0,144	0,12-0,173	0,15-0,216	0,18-0,25
	900-1200	260-350	0,008-0,014	0,019-0,024	0,03-0,04	0,04-0,05	0,06-0,075	0,075-0,095	0,095-0,12	0,11-0,145	0,14-0,17	0,16-0,2
	900-1400	210-400	0,01-0,02	0,02-0,03	0,25-0,045	0,036-0,066	0,05-0,071	0,065-0,12	0,08-0,15	0,098-0,18	0,122-0,225	0,14-0,26



Aluminium VHM Schruppfräser 3 Schneiden

Aluminium UMG solid carbide roughing end mill 3 flutes

Fraise ébauche aluminium à micrograin en carbure monobloc 3 dents

Aluminium VHM Fräser 2 Schneiden

Aluminium UMG solid carbide end mill 2 flutes

Fraise aluminium à micrograin en carbure monobloc 2 dents

Aluminium VHM Fräser 3 Schneiden

Aluminium UMG solid carbide end mill 3 flutes

Fraise aluminium à micrograin en carbure monobloc 3 dents

Materialgruppen Material groups Groupes matières	N/mm ²	HB	Ø 1	Ø 2	Ø 3	Ø 4	Ø 6	Ø 8	Ø 10	Ø 12	Ø 16	Ø 20
P Nicht legierter Stahl Non-alloyed steel Acier non allié	≤ 700	≤ 210	0,008-0,012	0,01-0,014	0,015-0,02	0,025-0,03	0,03-0,05	0,04-0,05	0,06-0,08	0,07-0,09	0,11-0,14	0,12-0,15
			0,008-0,012	0,01-0,014	0,015-0,02	0,025-0,03	0,03-0,05	0,04-0,05	0,06-0,08	0,07-0,09	0,11-0,14	0,12-0,15
			0,006-0,008	0,008-0,012	0,014-0,016	0,022-0,026	0,025-0,04	0,03-0,04	0,04-0,06	0,06-0,08	0,08-0,1	0,1-0,13
H Wenig legierter Stahl Low-alloyed steel Acier faible allié	700-1000	>300	0,006-0,008	0,008-0,012	0,014-0,016	0,022-0,026	0,025-0,04	0,03-0,04	0,04-0,06	0,06-0,08	0,08-0,1	0,1-0,13
			0,005	0,008	0,012	0,015	0,2	0,025	0,035	0,05	0,06	0,08
			0,004	0,006	0,01	0,012	0,015	0,02	0,03	0,04	0,05	0,07
M Edelstahl Stainless Steel Acier inoxydable	500-950	250-320	0,004-0,006	0,08-0,012	0,012-0,016	0,018-0,025	0,022-0,03	0,04-0,06	0,05-0,07	0,06-0,09	0,08-0,1	0,09-0,15
			0,08-0,011	0,01-0,016	0,015-0,025	0,025-0,035	0,03-0,065	0,04-0,08	0,06-0,09	0,08-0,11	0,09-0,012	0,11-0,16
			0,008-0,01	0,015-0,02	0,018-0,025	0,02-0,04	0,03-0,06	0,04-0,07	0,05-0,08	0,06-0,09	0,08-0,12	0,1-0,15
K Gusseisen Cast Iron Fonte	180-280	Si 0,5-12%	0,008-0,01	0,015-0,02	0,018-0,025	0,02-0,04	0,03-0,06	0,04-0,07	0,05-0,08	0,06-0,09	0,08-0,12	0,1-0,15
			0,006-0,008	0,008-0,012	0,012-0,02	0,012-0,025	0,015-0,04	0,02-0,05	0,03-0,06	0,04-0,07	0,06-0,1	0,08-0,12
			0,005-0,01	0,01-0,02	0,01-0,03	0,02-0,04	0,04-0,06	0,05-0,08	0,06-0,1	0,1-0,14	0,1-0,16	0,15-0,2
N Plastik Plastique	180-250	Gusswerkstoffe Composite material Matériaux de moulage	0,005-0,01	0,01-0,02	0,01-0,03	0,02-0,04	0,04-0,06	0,05-0,08	0,06-0,1	0,1-0,14	0,1-0,16	0,15-0,2
			0,005-0,01	0,01-0,02	0,01-0,03	0,02-0,04	0,04-0,06	0,05-0,08	0,06-0,1	0,1-0,14	0,1-0,16	0,15-0,2
			0,005-0,007	0,006-0,009	0,009-0,013	0,014-0,021	0,032-0,04	0,048-0,07	0,072-0,11	0,087-0,13	0,11-0,16	0,14-0,21
S Titanium Titanium	700-1250	Titanium	0,005-0,007	0,008-0,012	0,011-0,017	0,015-0,024	0,019-0,031	0,025-0,05	0,03-0,05	0,04-0,07	0,06-0,09	0,08-0,013
			0,005-0,006	0,007-0,01	0,01-0,015	0,015-0,024	0,019-0,031	0,025-0,05	0,03-0,05	0,04-0,07	0,06-0,09	0,08-0,013
			0,005-0,006	0,009-0,01	0,012-0,015	0,016-0,02	0,021-0,026	0,028-0,035	0,035-0,05	0,05-0,06	0,06-0,085	0,09-0,12



Aluminium UMG Solid carbide ball nose end mill 2 flutes
Fraise aluminium à bout hémisphérique en carbure monobloc 2 dents

Materialgruppen Material groups Groupes matières	N/mm ²	HB	Ø 1	Ø 2	Ø 3	Ø 4	Ø 6	Ø 8	Ø 10	Ø 12	Ø 16	Ø 20	
P Nicht legierter Stahl Non-alloyed steel Acier non allié	≤ 700	≤ 210	0,02-0,03	0,05-0,055	0,07-0,084	0,09-0,102	0,12-0,13	0,12-0,13	0,13-0,16	0,13-0,16	0,14-0,17	0,14-0,17	
	700-1000	210-300	0,02-0,03	0,05-0,055	0,07-0,084	0,09-0,102	0,12-0,13	0,12-0,13	0,13-0,16	0,13-0,16	0,14-0,17	0,14-0,17	
	≤ 1000	≤ 300	0,02-0,03	0,05-0,055	0,07-0,084	0,09-0,102	0,12-0,13	0,12-0,13	0,13-0,16	0,13-0,16	0,14-0,17	0,14-0,17	
H Stahl 30-38HRC Steel 30-38HRC Acier 30-38HRC Stahl 38-48 HRC Steel 38-48 HRC Acier 38-48 HRC Stahl 48-56 HRC Steel 48-56 HRC Acier 48-56 HRC Stahl 56-68 HRC Steel 56-68 HRC Acier 56-68 HRC			0,02-0,025	0,04-0,045	0,06-0,074	0,08-0,09	0,11-0,12	0,11-0,12	0,12-0,15	0,12-0,15	0,13-0,16	0,13-0,16	
			0,02-0,025	0,04-0,045	0,06-0,074	0,08-0,09	0,11-0,12	0,11-0,12	0,12-0,15	0,12-0,15	0,13-0,16	0,13-0,16	
			0,015-0,02	0,03-0,04	0,04-0,05	0,06-0,08	0,08-0,1	0,08-0,1	0,1-0,12	0,1-0,12	0,11-0,13	0,11-0,13	
			0,015-0,02	0,03-0,04	0,04-0,05	0,06-0,08	0,08-0,1	0,08-0,1	0,1-0,12	0,1-0,12	0,11-0,13	0,11-0,13	
		500-950	250-320	0,02-0,025	0,04-0,045	0,06-0,074	0,08-0,09	0,11-0,12	0,11-0,12	0,12-0,15	0,12-0,15	0,13-0,16	0,13-0,16
			180-280	0,02-0,03	0,05-0,055	0,07-0,084	0,09-0,102	0,12-0,13	0,12-0,13	0,13-0,16	0,13-0,16	0,14-0,17	0,14-0,17
M Edelstahl Stainless Steel Acier inoxydable			0,03-0,05	0,05-0,07	0,06-0,09	0,12-0,15	0,15-0,2	0,18-0,24	0,22-0,26	0,25-0,3	0,28-0,32	0,3-0,35	
			0,03-0,05	0,05-0,07	0,06-0,09	0,12-0,15	0,15-0,2	0,18-0,24	0,22-0,26	0,25-0,3	0,28-0,32	0,3-0,35	
			0,03-0,05	0,05-0,07	0,06-0,09	0,12-0,15	0,15-0,2	0,18-0,24	0,25-0,35	0,3-0,4	0,4-0,5	0,5-0,6	
K Gusseisen Cast Iron Fonte			0,03-0,05	0,05-0,07	0,06-0,09	0,12-0,15	0,15-0,2	0,18-0,24	0,22-0,26	0,25-0,3	0,28-0,32	0,3-0,35	
			0,03-0,05	0,05-0,07	0,06-0,09	0,12-0,15	0,15-0,2	0,18-0,24	0,22-0,26	0,25-0,3	0,28-0,32	0,3-0,35	
			0,03-0,05	0,05-0,07	0,06-0,09	0,12-0,15	0,15-0,2	0,18-0,24	0,25-0,35	0,3-0,4	0,4-0,5	0,5-0,6	
N Gusswerkstoffe Composite material Matériaux de moulage			0,03-0,05	0,05-0,07	0,06-0,09	0,12-0,15	0,15-0,2	0,18-0,24	0,22-0,26	0,25-0,3	0,28-0,32	0,3-0,35	
			0,03-0,05	0,05-0,07	0,06-0,09	0,12-0,15	0,15-0,2	0,18-0,24	0,22-0,26	0,25-0,3	0,28-0,32	0,3-0,35	
			0,03-0,05	0,05-0,07	0,06-0,09	0,12-0,15	0,15-0,2	0,18-0,24	0,22-0,26	0,25-0,3	0,28-0,32	0,3-0,35	
S Nickel Nickel/ Nickel			0,04-0,08	0,06-0,08	0,1-0,12	0,1-0,13	0,15-0,18	0,2-0,23	0,24-0,28	0,26-0,3	0,3-0,33	0,32-0,36	
			0,04-0,08	0,06-0,08	0,1-0,12	0,1-0,13	0,15-0,18	0,2-0,23	0,24-0,28	0,26-0,3	0,3-0,33	0,32-0,36	
			0,04-0,08	0,06-0,08	0,1-0,12	0,1-0,13	0,15-0,18	0,2-0,23	0,24-0,28	0,26-0,3	0,3-0,33	0,32-0,36	
Titanium Titanium Titanium			0,015-0,02	0,03-0,04	0,04-0,05	0,06-0,08	0,08-0,1	0,08-0,1	0,1-0,12	0,1-0,12	0,11-0,13	0,11-0,13	
			0,015-0,02	0,03-0,04	0,04-0,05	0,06-0,08	0,08-0,1	0,08-0,1	0,1-0,12	0,1-0,12	0,11-0,13	0,11-0,13	
			0,015-0,02	0,03-0,04	0,04-0,05	0,06-0,08	0,08-0,1	0,08-0,1	0,1-0,12	0,1-0,12	0,11-0,13	0,11-0,13	
Hitze-resistenter Stahl Heat resistant steel Acier thermorésistant			0,015-0,02	0,03-0,04	0,04-0,05	0,06-0,08	0,08-0,1	0,08-0,1	0,1-0,12	0,1-0,12	0,11-0,13	0,11-0,13	
			0,015-0,02	0,03-0,04	0,04-0,05	0,06-0,08	0,08-0,1	0,08-0,1	0,1-0,12	0,1-0,12	0,11-0,13	0,11-0,13	
			0,015-0,02	0,03-0,04	0,04-0,05	0,06-0,08	0,08-0,1	0,08-0,1	0,1-0,12	0,1-0,12	0,11-0,13	0,11-0,13	



HSS-E Gewindebohrer Metrisches ISO-Gewinde für Grundlochgewinde

HSS-E spiral flute taps for multi-purpose ISO metric coarse threads for blind holes
Taraud HSS-E avec filetage métrique pour filetage trou borgne

HSS-E	DIN 371/376	Tol. 6 H	DIN 13	Typ N				900 N/mm ²
-------	-------------	----------	--------	-------	--	--	--	-----------------------



1. Gewinde in spezieller Ausführung, verhindert zu großen Vorschub, dünnes Gewinde und zu große Steigung.
2. Nutenform in spezieller Ausführung, bessere Spanabfuhr, kein Spänestau, verbessert die Gewindequalität
3. Hervorragende Leistung in vielen Werkstoffen: rostfreie Stähle, Kohlenstoffstähle, legierte Stähle, Werkzeugstähle

1. Thread configuration with a special design, prevents overfeeding, thin thread and pitch diameter oversize.
2. Flute geometry with special design, better chip evacuation, prevents chip clogging, improves thread quality
3. Excellent performance on various work material: Stainless steel, carbon steel, alloyed steel, tool steel

1. Filetage en conception spéciale, empêche avancement excessive, filetage mince et de pente grande.
2. Flûte en exécution spéciale, meilleure évacuation des copeaux, pas de congestion de copeaux, amélioration de la qualité du filetage
3. Excellente performance dans de nombreux matériaux: aciers inoxydables, aciers au carbone, aciers alliés, aciers à outils

Bestell Nr. Order no. Référence	d ₁	Steigung Pitch Pente	l ₁	l ₂	d ₂	a	Ø mm
DIN 371							
C.2050.M2.0	M2	0,4	45,0	6,0	2,8	2,1	1,6
C.2050.M2.5	M2.5	0,45	50,0	7,5	2,8	2,1	2,05
C.2050.M3.0	M3	0,5	56,0	6,0	3,5	2,7	2,5
C.2050.M3.5	M3.5	0,6	56,0	7,0	4,0	3,0	2,9
C.2050.M4.0	M4	0,7	63,0	7,0	4,5	3,4	3,3
C.2050.M5.0	M5	0,8	70,0	8,0	6,0	4,9	4,2
C.2050.M6.0	M6	1,0	80,0	10,0	6,0	4,9	5,0
C.2050.M8.0	M8	1,25	90,0	13,0	8,0	6,2	6,8
C.2050.M10.0	M10	1,5	100,0	15,0	10,0	8,0	8,5
DIN 376							
C.4050.M12.0	M12	1,75	110,0	18,0	9,0	7,0	10,2
C.4050.M14.0	M14	2,0	110,0	20,0	11,0	9,0	12,0
C.4050.M16.0	M16	2,0	110,0	20,0	12,0	9,0	14,0
C.4050.M18.0	M18	2,5	125,0	25,0	14,0	11,0	15,5
C.4050.M20.0	M20	2,5	140,0	25,0	16,0	12,0	17,5
C.4050.M22.0	M22	2,5	140,0	25,0	18,0	14,0	19,5
C.4050.M24.0	M24	3,0	160,0	30,0	18,0	14,0	21,0
C.4050.M27.0	M27	3,0	160,0	30,0	20,0	16,0	24,0
C.4050.M30.0	M30	3,5	180,0	35,0	22,0	18,0	26,5
C.4050.M33.0	M33	3,5	180,0	35,0	25,0	20,0	29,5
C.4050.M36.0	M36	4,0	200,0	40,0	28,0	22,0	32,0

HSS-E spiral flute taps for multi-purpose ISO metric coarse threads for blind holes
 Taraud HSS-E avec filetage métrique pour filetage trou borgne

HSS-E	DIN 371/376	Tol. 6 H	DIN 13	Typ N				900 N/mm ²
-------	-------------	----------	--------	-------	--	--	--	-----------------------

TiN

Titanium Nitrid beschichtet / Titanitrid coating
 Revêtu de nitrure de titane

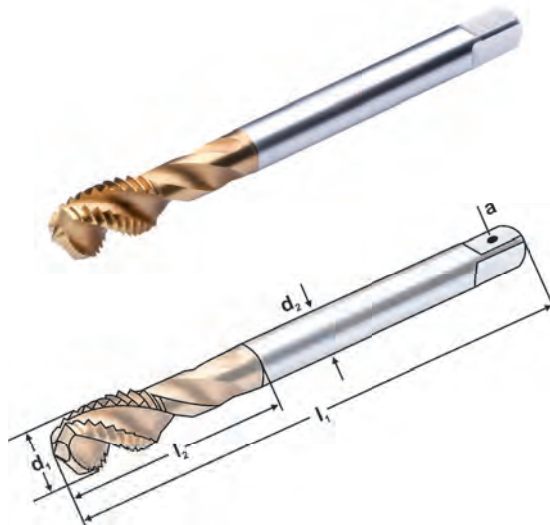

1. Gewinde in spezieller Ausführung, verhindert zu großen Vorschub, dünnes Gewinde und zu große Steigung.
2. Nutenform in spezieller Ausführung, bessere Spanabfuhr, kein Spänestau, verbessert die Gewindequalität
3. Hervorragende Leistung in vielen Werkstoffen: rostfreie Stähle, Kohlenstoffstähle, legierte Stähle, Werkzeugstähle

1. Thread configuration with a special design, prevents overfeeding, thin thread and pitch diameter oversize.

2. Flute geometry with special design, better chip evacuation, prevents chip clogging, improves thread quality

3. Excellent performance on various work material: Stainless steel, carbon steel, alloyed steel, tool steel

1. Filetage en conception spéciale, empêche avancement excessive, filetage mince et de pente grande.

2. Flûte en exécution spéciale, meilleure évacuation des copeaux, pas de congestion de copeaux, amélioration de la qualité du filetage

3. Excellente performance dans de nombreux matériaux: aciers inoxydables, aciers au carbone, aciers alliés, aciers à outils

Bestell Nr. Order no. Référence	d ₁	Steigung Pitch Pente	l ₁	l ₂	d ₂	a	Ø mm
DIN 371							
TC.2060.M2.0	M2	0,4	45,0	6,0	2,8	2,1	1,6
TC.2060.M2.5	M2,5	0,45	50,0	7,5	2,8	2,1	2,05
TC.2060.M3.0	M3	0,5	56,0	6,0	3,5	2,7	2,5
TC.2060.M3.5	M3,5	0,6	56,0	7,0	4,0	3,0	2,9
TC.2060.M4.0	M4	0,7	63,0	7,0	4,5	3,4	3,3
TC.2060.M5.0	M5	0,8	70,0	8,0	6,0	4,9	4,2
TC.2060.M6.0	M6	1,0	80,0	10,0	6,0	4,9	5,0
TC.2060.M8.0	M8	1,25	90,0	13,0	8,0	6,2	6,8
TC.2060.M10.0	M10	1,5	100,0	15,0	10,0	8,0	8,5
DIN 376							
TC.4060.M12.0	M12	1,75	110,0	18,0	9,0	7,0	10,2
TC.4060.M14.0	M14	2,0	110,0	20,0	11,0	9,0	12,0
TC.4060.M16.0	M16	2,0	110,0	20,0	12,0	9,0	14,0
TC.4060.M18.0	M18	2,5	125,0	25,0	14,0	11,0	15,5
TC.4060.M20.0	M20	2,5	140,0	25,0	16,0	12,0	17,5
TC.4060.M22.0	M22	2,5	140,0	25,0	18,0	14,0	19,5
TC.4060.M24.0	M24	3,0	160,0	30,0	18,0	14,0	21,0
TC.4060.M27.0	M27	3,0	160,0	30,0	20,0	16,0	24,0
TC.4060.M30.0	M30	3,5	180,0	35,0	22,0	18,0	26,5
TC.4060.M33.0	M33	3,5	180,0	35,0	25,0	20,0	29,5
TC.4060.M36.0	M36	4,0	200,0	40,0	28,0	22,0	32,0



HSS-E Gewindebohrer Metrisches ISO-Gewinde für Durchgangsgewinde

HSS-E spiral flute taps for multi-purpose ISO metric coarse threads for through holes
 Taraud HSS-E avec filetage métrique pour filetage trou de passage

HSS-E	DIN 371/376	Tol. 6 H	DIN 13	Typ N		B 3,5 - 6		900 N/mm ²
-------	-------------	----------	--------	-------	--	--------------	--	-----------------------

1. Gewinde in spezieller Ausführung, verhindert zu großen Vorschub, dünnes Gewinde und zu große Steigung.
2. Nutenform in spezieller Ausführung, bessere Spanabfuhr, kein Spänestau, verbessert die Gewindequalität
3. Hervorragende Leistung in vielen Werkstoffen: rostfreie Stähle, Kohlenstoffstähle, legierte Stähle, Werkzeugstähle

1. Thread configuration with a special design, prevents overfeeding, thin thread and pitch diameter oversize.
2. Flute geometry with special design, better chip evacuation, prevents chip clogging, improves thread quality
3. Excellent performance on various work material: Stainless steel, carbon steel, alloyed steel, tool steel

1. Filetage en conception spéciale, empêche avancement excessive, filetage mince et de pente grande.
2. Flûte en exécution spéciale, meilleure évacuation des copeaux, pas de congestion de copeaux, amélioration de la qualité du filetage
3. Excellente performance dans de nombreux matériaux: aciers inoxydables, aciers au carbone, aciers alliés, aciers à outils



Bestell Nr. Order no. Référence	d ₁	Steigung Pitch Pente	l ₁	l ₂	d ₂	a	
DIN 371							
B.1500.M2.0	M2	0,4	45,0	8,0	2,8	2,1	1,6
B.1500.M2.5	M2,5	0,45	50,0	9,0	2,8	2,1	2,05
B.1500.M3.0	M3	0,5	56,0	11,0	3,5	2,7	2,5
B.1500.M3.5	M3,5	0,6	56,0	12,0	4,0	3,0	2,9
B.1500.M4.0	M4	0,7	63,0	13,0	4,5	3,4	3,3
B.1500.M5.0	M5	0,8	70,0	15,0	6,0	4,9	4,2
B.1500.M6.0	M6	1,0	80,0	15,0	6,0	4,9	5,0
B.1500.M8.0	M8	1,25	90,0	20,0	8,0	6,2	6,8
B.1500.M10.0	M10	1,5	100,0	22,0	10,0	8,0	8,5
DIN 376							
B.3500.M12.0	M12	1,75	110,0	24,0	9,0	7,0	10,2
B.3500.M14.0	M14	2,0	110,0	26,0	11,0	9,0	12,0
B.3500.M16.0	M16	2,0	110,0	27,0	12,0	9,0	14,0
B.3500.M18.0	M18	2,5	125,0	30,0	14,0	11,0	15,5
B.3500.M20.0	M20	2,5	140,0	32,0	16,0	12,0	17,5
B.3500.M22.0	M22	2,5	140,0	32,0	18,0	14,0	19,5
B.3500.M24.0	M24	3,0	160,0	34,0	18,0	14,0	21,0
B.3500.M27.0	M27	3,0	160,0	36,0	20,0	16,0	24,0
B.3500.M30.0	M30	3,5	180,0	40,0	22,0	18,0	26,5
B.3500.M33.0	M33	3,5	180,0	42,0	25,0	20,0	29,5
B.3500.M36.0	M36	3,5	200,0	50,0	28,0	22,0	32,0

HSS-E spiral flute taps for multi-purpose ISO metric coarse threads for through holes Taraud HSS-E avec filetage métrique pour filetage trou de passage

HSS-E	DIN 371/376	Tol. 6 H	DIN 13	Typ N		B 3,5 - 6		900 N/mm ²
-------	-------------	----------	--------	-------	--	---------------------	--	-----------------------

TiN

Titanium Nitrid beschichtet / *Titanitrid coating*
Revêtu de nitrure de titane

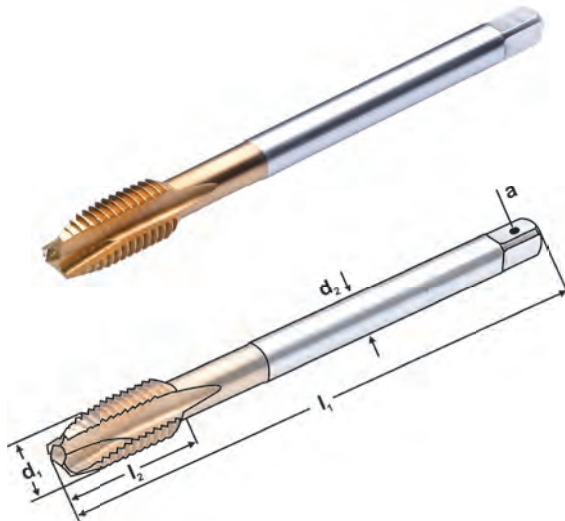

1. Gewinde in spezieller Ausführung, verhindert zu großen Vorschub, dünnes Gewinde und zu große Steigung.
2. Nutenform in spezieller Ausführung, bessere Spanabfuhr, kein Spänestau, verbessert die Gewindequalität
3. Hervorragende Leistung in vielen Werkstoffen: rostfreie Stähle, Kohlenstoffstähle, legierte Stähle, Werkzeugstähle

1. Thread configuration with a special design, prevents overfeeding, thin thread and pitch diameter oversize.
2. Flute geometry with special design, better chip evacuation, prevents chip clogging, improves thread quality
3. Excellent performance on various work material: Stainless steel, carbon steel, alloyed steel, tool steel

1. Filetage en conception spéciale, empêche avancement excessive, filetage mince et de pente grande.
2. Flûte en exécution spéciale, meilleure évacuation des copeaux, pas de congestion de copeaux, amélioration de la qualité du filetage
3. Excellente performance dans de nombreux matériaux: aciers inoxydables, aciers au carbone, aciers alliés, aciers à outils

Bestell Nr. Order no. Référence	d ₁	Steigung Pitch Pente	l ₁	l ₂	d ₂	a	Ø mm
DIN 371							
TB.1510.M2.0	M2	0,4	45,0	8,0	2,8	2,1	1,6
TB.1510.M2.5	M2,5	0,45	50,0	9,0	2,8	2,1	2,05
TB.1510.M3.0	M3	0,5	56,0	11,0	3,5	2,7	2,5
TB.1510.M3.5	M3,5	0,6	56,0	12,0	4,0	3,0	2,9
TB.1510.M4.0	M4	0,7	63,0	13,0	4,5	3,4	3,3
TB.1510.M5.0	M5	0,8	70,0	15,0	6,0	4,9	4,2
TB.1510.M6.0	M6	1,0	80,0	15,0	6,0	4,9	5,0
TB.1510.M8.0	M8	1,25	90,0	20,0	8,0	6,2	6,8
TB.1510.M10.0	M10	1,5	100,0	22,0	10,0	8,0	8,5
DIN 376							
TB.3510.M12.0	M12	1,75	110,0	24,0	9,0	7,0	10,2
TB.3510.M14.0	M14	2,0	110,0	26,0	11,0	9,0	12,0
TB.3510.M16.0	M16	2,0	110,0	27,0	12,0	9,0	14,0
TB.3510.M18.0	M18	2,5	125,0	30,0	14,0	11,0	15,5
TB.3510.M20.0	M20	2,5	140,0	32,0	16,0	12,0	17,5
TB.3510.M22.0	M22	2,5	140,0	32,0	18,0	14,0	19,5
TB.3510.M24.0	M24	3,0	160,0	34,0	18,0	14,0	21,0
TB.3510.M27.0	M27	3,0	160,0	36,0	20,0	16,0	24,0
TB.3510.M30.0	M30	3,5	180,0	40,0	22,0	18,0	26,5
TB.3510.M33.0	M33	3,5	180,0	42,0	25,0	20,0	29,5
TB.3510.M36.0	M36	3,5	200,0	50,0	28,0	22,0	32,0



HSS-E Gewindebohrer Metrisches ISO-Feingewinde für Grundlochgewinde

HSS-E spiral flute taps for multi-purpose ISO metric fine threads for blind holes
Taraud HSS-E avec filetage métrique fin pour filetage trou borgne

HSS-E	DIN 374	Tol. 6 H	DIN 13	Typ N				900 N/mm ²
-------	---------	----------	--------	-------	--	--	--	-----------------------



1. Gewinde in spezieller Ausführung, verhindert zu großen Vorschub, dünnes Gewinde und zu große Steigung.
2. Nutenform in spezieller Ausführung, bessere Spanabfuhr, kein Spänestau, verbessert die Gewindequalität
3. Hervorragende Leistung in vielen Werkstoffen: rostfreie Stähle, Kohlenstoffstähle, legierte Stähle, Werkzeugstähle

1. Thread configuration with a special design, prevents overfeeding, thin thread and pitch diameter oversize.

2. Flute geometry with special design, better chip evacuation, prevents chip clogging, improves thread quality

3. Excellent performance on various work material: Stainless steel, carbon steel, alloyed steel, tool steel

1. Filetage en conception spéciale, empêche avancement excessive, filetage mince et de pente grande.

2. Flûte en exécution spéciale, meilleure évacuation des copeaux, pas de congestion de copeaux, amélioration de la qualité du filetage

3. Excellente performance dans de nombreux matériaux: aciers inoxydables, aciers au carbone, aciers alliés, aciers à outils

Bestell Nr. Order no. Référence	d ₁	Steigung Pitch Pente	l ₁	l ₂	d ₂	a	 Ø mm
FC.4050.M4.0	M4	0,5	63	7	2,8	2,1	3,5
FC.4050.M5.0	M5	0,5	80	8	3,5	2,7	4,5
FC.4050.M6.1	M6	0,75	80	10	4,5	3,4	5,2
FC.4050.M6.2	M6	0,5	80	10	4,5	3,4	5,5
FC.4050.M7.0	M7	0,75	80	10	5,5	4,3	6,2
FC.4050.M8.1	M8	1	90	13	6,0	4,9	7,0
FC.4050.M8.2	M8	0,75	80	10	6,0	4,9	7,2
FC.4050.M9.0	M9	1	90	13	7,0	5,5	8,0
FC.4050.M10.1	M10	1,25	100	15	7,0	5,5	8,8
FC.4050.M10.2	M10	1	90	12	7,0	5,5	9,0
FC.4050.M10.3	M10	0,75	90	12	7,0	5,5	9,2
FC.4050.M11	M11	1	90	12	8,0	6,2	10,0
FC.4050.M12.1	M12	1,5	100	14	9,0	7,0	10,5
FC.4050.M12.2	M12	1,25	100	14	9,0	7,0	10,8
FC.4050.M12.3	M12	1	100	14	9,0	7,0	11,0
FC.4050.M14.1	M14	1,5	100	16	11,0	9,0	12,5
FC.4050.M14.2	M14	1,25	100	16	11,0	9,0	12,8
FC.4050.M14.3	M14	1	100	16	11,0	9,0	13,0
FC.4050.M15	M15	1	100	16	12,0	9,0	14,0
FC.4050.M16.1	M16	1,5	100	16	12,0	9,0	14,5
FC.4050.M16.2	M16	1	100	16	12,0	9,0	15,0

HSS-E spiral flute taps for multi-purpose ISO metric fine threads for blind holes Taraud HSS-E avec filetage métrique fin pour filetage trou borgne

HSS-E	DIN 374	Tol. 6 H	DIN 13	Typ N				900 N/mm ²
-------	---------	----------	--------	-------	--	--	--	-----------------------

TiN

Titanium Nitrid beschichtet / *Titanitrid coating*
Revêtu de nitrure de titane



1. Gewinde in spezieller Ausführung, verhindert zu großen Vorschub, dünnes Gewinde und zu große Steigung.

2. Nutenform in spezieller Ausführung, bessere Spanabfuhr, kein Spänestau, verbessert die Gewindequalität

3. Hervorragende Leistung in vielen Werkstoffen: rostfreie Stähle, Kohlenstoffstähle, legierte Stähle, Werkzeugstähle

1. Thread configuration with a special design, prevents overfeeding, thin thread and pitch diameter oversize.

2. Flute geometry with special design, better chip evacuation, prevents chip clogging, improves thread quality

3. Excellent performance on various work material: Stainless steel, carbon steel, alloyed steel, tool steel

1. Filetage en conception spéciale, empêche avancement excessive, filetage mince et de pente grande.

2. Flûte en exécution spéciale, meilleure évacuation des copeaux, pas de congestion de copeaux, amélioration de la qualité du filetage

3. Excellente performance dans de nombreux matériaux: aciers inoxydables, aciers au carbone, aciers alliés, aciers à outils

Bestell Nr. Order no. Référence	d ₁	Steigung Pitch Pente	l ₁	l ₂	d ₂	a	 Ø mm
TFC.4060.M4.0	M4	0,5	63	7	2,8	2,1	3,5
TFC.4060.M5.0	M5	0,5	80	8	3,5	2,7	4,5
TFC.4060.M6.1	M6	0,75	80	10	4,5	3,4	5,2
TFC.4060.M6.2	M6	0,5	80	10	4,5	3,4	5,5
TFC.4060.M7.0	M7	0,75	80	10	5,5	4,3	6,2
TFC.4060.M8.1	M8	1	90	13	6,0	4,9	7,0
TFC.4060.M8.2	M8	0,75	80	10	6,0	4,9	7,2
TFC.4060.M9.0	M9	1	90	13	7,0	5,5	8,0
TFC.4060.M10.1	M10	1,25	100	15	7,0	5,5	8,8
TFC.4060.M10.2	M10	1	90	12	7,0	5,5	9,0
TFC.4060.M10.3	M10	0,75	90	12	7,0	5,5	9,2
TFC.4060.M11	M11	1	90	12	8,0	6,2	10,0
TFC.4060.M12.1	M12	1,5	100	14	9,0	7,0	10,5
TFC.4060.M12.2	M12	1,25	100	14	9,0	7,0	10,8
TFC.4060.M12.3	M12	1	100	14	9,0	7,0	11,0
TFC.4060.M14.1	M14	1,5	100	16	11,0	9,0	12,5
TFC.4060.M14.2	M14	1,25	100	16	11,0	9,0	12,8
TFC.4060.M14.3	M14	1	100	16	11,0	9,0	13,0
TFC.4060.M15	M15	1	100	16	12,0	9,0	14,0
TFC.4060.M16.1	M16	1,5	100	16	12,0	9,0	14,5
TFC.4060.M16.2	M16	1	100	16	12,0	9,0	15,0



HSS-E Gewindebohrer Metrisches ISO-Feingewinde für Durchgangsgewinde

HSS-E spiral flute taps for multi-purpose ISO metric fine threads for through holes
Taraud HSS-E avec filetage métrique fin pour filetage trou de passage

HSS-E	DIN 374	Tol. 6 H	DIN 13	Typ N		B 3,5 - 6		900 N/mm ²
-------	---------	----------	--------	-------	---	--------------	---	-----------------------



1. Gewinde in spezieller Ausführung, verhindert zu großen Vorschub, dünnes Gewinde und zu große Steigung.
2. Nutenform in spezieller Ausführung, bessere Spanabfuhr, kein Spänestau, verbessert die Gewindequalität
3. Hervorragende Leistung in vielen Werkstoffen: rostfreie Stähle, Kohlenstoffstähle, legierte Stähle, Werkzeugstähle

1. Thread configuration with a special design, prevents overfeeding, thin thread and pitch diameter oversize.

2. Flute geometry with special design, better chip evacuation, prevents chip clogging, improves thread quality

3. Excellent performance on various work material: Stainless steel, carbon steel, alloyed steel, tool steel

1. Filetage en conception spéciale, empêche avancement excessive, filetage mince et de pente grande.

2. Flûte en exécution spéciale, meilleure évacuation des copeaux, pas de congestion de copeaux, amélioration de la qualité du filetage

3. Excellente performance dans de nombreux matériaux: aciers inoxydables, aciers au carbone, aciers alliés, aciers à outils

Bestell Nr. Order no. Référence	d ₁	Steigung Pitch Pente	l ₁	l ₂	d ₂	a	 Ø mm
FB.3500.M4.0	M4	0,5	63	12	2,8	2,1	3,5
FB.3500.M5.0	M5	0,5	70	13	3,5	2,7	4,5
FB.3500.M6.1	M6	0,75	80	15	4,5	3,4	5,2
FB.3500.M6.2	M6	0,5	80	15	4,5	3,4	5,5
FB.3500.M7.0	M7	0,75	80	15	5,5	4,3	6,2
FB.3500.M8.1	M8	1,0	90	18	6,0	4,9	7,0
FB.3500.M8.2	M8	0,75	80	15	6,0	4,9	7,2
FB.3500.M10.1	M10	1,25	100	20	7,0	5,5	8,8
FB.3500.M10.2	M10	1,0	90	20	7,0	5,5	9,0
FB.3500.M10.3	M10	0,75	90	20	7,0	5,5	9,2
FB.3500.M12.1	M12	1,5	100	21	9,0	7,0	10,5
FB.3500.M12.2	M12	1,25	100	21	9,0	7,0	10,8
FB.3500.M12.3	M12	1,0	100	21	9,0	7,0	11,0
FB.3500.M14.1	M14	1,5	100	21	11,0	9,0	12,5
FB.3500.M14.2	M14	1,25	100	21	11,0	9,0	12,8
FB.3500.M14.3	M14	1,0	100	21	11,0	9,0	13,0
FB.3500.M15.1	M15	1,5	100	21	12,0	9,0	13,5
FB.3500.M15.2	M15	1,0	100	21	12,0	9,0	14,0
FB.3500.M16.1	M16	1,5	100	21	12,0	9,0	14,5
FB.3500.M16.2	M16	1,0	100	21	12,0	9,0	15,0

HSS-E spiral flute taps for multi-purpose ISO metric fine threads for through holes Taraud HSS-E avec filetage métrique fin pour filetage trou de passage

HSS-E	DIN 374	Tol. 6 H	DIN 13	Typ N				900 N/mm ²
-------	---------	----------	--------	-------	--	--	--	-----------------------

TiN

Titanium Nitrid beschichtet / *Titanitrid coating*
Revêtu de nitrure de titane

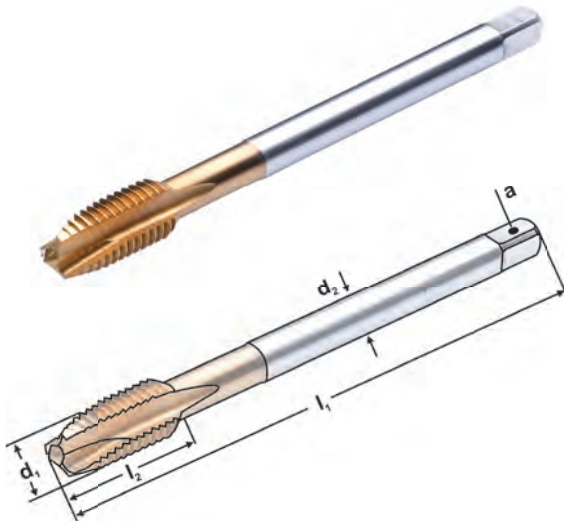

1. Gewinde in spezieller Ausführung, verhindert zu großem Vorschub, dünnes Gewinde und zu große Steigung.

2. Nutenform in spezieller Ausführung, bessere Spanabfuhr, kein Spänestau, verbessert die Gewindegüte

3. Hervorragende Leistung in vielen Werkstoffen: rostfreie Stähle, Kohlenstoffstähle, legierte Stähle, Werkzeugstähle

1. Thread configuration with a special design, prevents over-feeding, thin thread and pitch diameter oversize.

2. Flute geometry with special design, better chip evacuation, prevents chip clogging, improves thread quality

3. Excellent performance on various work material: Stainless steel, carbon steel, alloyed steel, tool steel

1. Filetage en conception spéciale, empêche avancement excessif, filetage mince et de pente grande.

2. Flûte en exécution spéciale, meilleure évacuation des copeaux, pas de congestion de copeaux, amélioration de la qualité du filetage

3. Excellente performance dans de nombreux matériaux: aciers inoxydables, aciers au carbone, aciers alliés, aciers à outils

Bestell Nr. Order no. Référence	d ₁	Steigung Pitch Pente	l ₁	l ₂	d ₂	a	Ø mm
TFB.3510.M4.0	M4	0,5	63	12	2,8	2,1	3,5
TFB.3510.M5.0	M5	0,5	70	13	3,5	2,7	4,5
TFB.3510.M6.1	M6	0,75	80	15	4,5	3,4	5,2
TFB.3510.M6.2	M6	0,5	80	15	4,5	3,4	5,5
TFB.3510.M7.0	M7	0,75	80	15	5,5	4,3	6,2
TFB.3510.M8.1	M8	1,0	90	18	6,0	4,9	7,0
TFB.3510.M8.2	M8	0,75	80	15	6,0	4,9	7,2
TFB.3510.M10.1	M10	1,25	100	20	7,0	5,5	8,8
TFB.3510.M10.2	M10	1,0	90	20	7,0	5,5	9,0
TFB.3510.M10.3	M10	0,75	90	20	7,0	5,5	9,2
TFB.3510.M12.1	M12	1,5	100	21	9,0	7,0	10,5
TFB.3510.M12.2	M12	1,25	100	21	9,0	7,0	10,8
TFB.3510.M12.3	M12	1,0	100	21	9,0	7,0	11,0
TFB.3510.M14.1	M14	1,5	100	21	11,0	9,0	12,5
TFB.3510.M14.2	M14	1,25	100	21	11,0	9,0	12,8
TFB.3510.M14.3	M14	1,0	100	21	11,0	9,0	13,0
TFB.3510.M15.1	M15	1,5	100	21	12,0	9,0	13,5
TFB.3510.M15.2	M15	1,0	100	21	12,0	9,0	14,0
TFB.3510.M16.1	M16	1,5	100	21	12,0	9,0	14,5
TFB.3510.M16.2	M16	1,0	100	21	12,0	9,0	15,0



HSS-E Gewindebohrer Satz Metrisches ISO-Gewinde für Grundlochgewinde

Set of HSS-E spiral flute taps for multi-purpose ISO metric coarse threads for blind holes
Set de tarauds HSS-E avec filetage métrique pour filetage trou borgne

HSS-E	DIN 371/376	Tol. 6 H	DIN 13	Typ N				900 N/mm ²
-------	-------------	----------	--------	-------	--	--	--	-----------------------



Bestell Nr.
Order no.
Référence

Abmessung
Size
Dimension

C.2050-S

(7tlg.) M3-M4-M5-M6-M8-M10-M12

HSS-E Gewindebohrer Satz Metrisches ISO-Gewinde für Grundlochgewinde

Set of HSS-E spiral flute taps for multi-purpose ISO metric coarse threads for blind holes
Set de tarauds HSS-E avec filetage métrique pour filetage trou borgne

HSS-E	DIN 371/376	Tol. 6 H	DIN 13	Typ N				900 N/mm ²
-------	-------------	----------	--------	-------	--	--	--	-----------------------

TiN

Titanium Nitrid beschichtet / Titanitrid coating
Revêtue de nitrure de titane



Bestell Nr.
Order no.
Référence

Abmessung
Size
Dimension

TC.2060-S

(7tlg.) M3-M4-M5-M6-M8-M10-M12

HSS-E Gewindebohrer Satz Metrisches ISO-Gewinde für Durchgangsgewinde



Set of HSS-E spiral flute taps for multi-purpose ISO metric coarse threads for through holes
 Set de tarauds HSS-E avec filetage métrique pour filetage trou de passage

HSS-E	DIN 371/376	Tol. 6 H	DIN 13	Typ N		B 3,5 - 6		900 N/mm ²
-------	-------------	----------	--------	-------	---	--------------	--	-----------------------



Bestell Nr. Order no. Référence	Abmessung Size Dimension
B.1500-S	(7tlg.) M3-M4-M5-M6-M8-M10-M12

HSS-E Gewindebohrer Satz Metrisches ISO-Gewinde für Durchgangsgewinde

Set of HSS-E spiral flute taps for multi-purpose ISO metric coarse threads for through holes
 Set de tarauds HSS-E avec filetage métrique pour filetage trou de passage

HSS-E	DIN 371/376	Tol. 6 H	DIN 13	Typ N		B 3,5 - 6		900 N/mm ²
-------	-------------	----------	--------	-------	---	--------------	---	-----------------------

TiN

Titanium Nitrid beschichtet / Titanitrid coating
 Revêtu de nitrure de titane



Bestell Nr. Order no. Référence	Abmessung Size Dimension
TB.1510-S	(7tlg.) M3-M4-M5-M6-M8-M10-M12

13



HSSE-Spiralbohrer DIN 338 - 130°

HSSE-twist DIN 338 drill - 130°
HSSE-forets DIN 338 - 130°

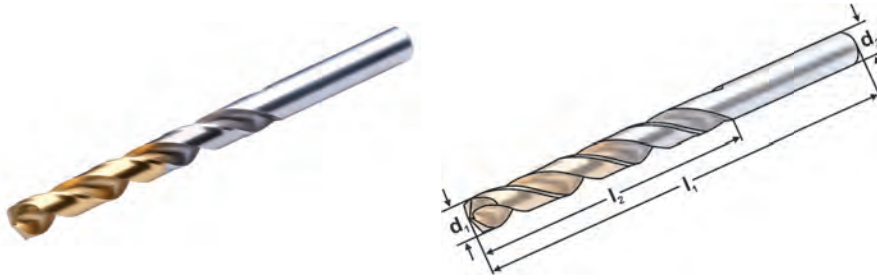

TIN coating

HSS-E



DIN 338



Besonders robust und stabil durch verstärkte Kerndicke. Profilgeschliffen, mit hoher Rundlaufgenauigkeit.
Particularly robust and strong due to strengthened core. Profile ground, with high concentricity.
Particulièrement rigides et résistants grâce à l'âme renforcée. Taillés avec une grande précision de concentricité.

P	H	M	K	N	S
●	○	○	●	○	○

Bestell Nr. Order no. Référence	d ₁ mm	d ₂ mm	l ₁ h6	l ₂ mm
D400HX0100	1,0	1	12	34
D400HX0110	1,1	1,1	14	36
D400HX0120	1,2	1,2	16	38
D400HX0130	1,3	1,3	16	38
D400HX0140	1,4	1,4	18	40
D400HX0150	1,5	1,5	18	40
D400HX0160	1,6	1,6	20	43
D400HX0170	1,7	1,7	20	43
D400HX0180	1,8	1,8	22	46
D400HX0190	1,9	1,9	22	46
D400HX0200	2,0	2	24	49
D400HX0210	2,1	2,1	24	49
D400HX0220	2,2	2,2	27	53
D400HX0230	2,3	2,3	27	53
D400HX0240	2,4	2,4	30	57
D400HX0250	2,5	2,5	30	57
D400HX0260	2,6	2,6	30	57
D400HX0270	2,7	2,7	33	61
D400HX0280	2,8	2,8	33	61
D400HX0290	2,9	2,9	33	61
D400HX0300	3,0	3	33	61
D400HX0310	3,1	3,1	36	65
D400HX0320	3,2	3,2	36	65
D400HX0330	3,3	3,3	36	65
D400HX0340	3,4	3,4	39	70
D400HX0350	3,5	3,5	39	70
D400HX0360	3,6	3,6	39	70
D400HX0370	3,7	3,7	39	70
D400HX0380	3,8	3,8	43	75
D400HX0390	3,9	3,9	43	75
D400HX0400	4,0	4	43	75
D400HX0410	4,1	4,1	43	75
D400HX0420	4,2	4,2	43	75
D400HX0430	4,3	4,3	47	80
D400HX0440	4,4	4,4	47	80
D400HX0450	4,5	4,5	47	80

Bestell Nr. Order no. Référence	d ₁ mm	d ₂ mm	l ₁ h6	l ₂ mm
D400HX0460	4,6	4,6	47	80
D400HX0470	4,7	4,7	47	80
D400HX0480	4,8	4,8	52	86
D400HX0490	4,9	4,9	52	86
D400HX0500	5,0	5	52	86
D400HX0510	5,1	5,1	52	86
D400HX0520	5,2	5,2	52	86
D400HX0530	5,3	5,3	52	86
D400HX0540	5,4	5,4	57	93
D400HX0550	5,5	5,5	57	93
D400HX0560	5,6	5,6	57	93
D400HX0570	5,7	5,7	57	93
D400HX0580	5,8	5,8	57	93
D400HX0590	5,9	5,9	57	93
D400HX0600	6,0	6	57	93
D400HX0610	6,1	6,1	63	101
D400HX0620	6,2	6,2	63	101
D400HX0630	6,3	6,3	63	101
D400HX0640	6,4	6,4	63	101
D400HX0650	6,5	6,5	63	101
D400HX0660	6,6	6,6	63	101
D400HX0670	6,7	6,7	63	101
D400HX0680	6,8	6,8	69	109
D400HX0690	6,9	6,9	69	109
D400HX0700	7,0	7	69	109
D400HX0710	7,1	7,1	69	109
D400HX0720	7,2	7,2	69	109
D400HX0730	7,3	7,3	69	109
D400HX0740	7,4	7,4	69	109
D400HX0750	7,5	7,5	69	109
D400HX0760	7,6	7,6	75	117
D400HX0770	7,7	7,7	75	117
D400HX0780	7,8	7,8	75	117
D400HX0790	7,9	7,9	75	117
D400HX0800	8,0	8	75	117
D400HX0810	8,1	8,1	75	117

Bestell Nr. Order no. Référence	d ₁ mm	d ₂ mm	l ₁ h6	l ₂ mm
D400HX0820	8,2	8,2	75	117
D400HX0830	8,3	8,3	75	117
D400HX0840	8,4	8,4	75	117
D400HX0850	8,5	8,5	75	117
D400HX0860	8,6	8,6	81	125
D400HX0870	8,7	8,7	81	125
D400HX0880	8,8	8,8	81	125
D400HX0890	8,9	8,9	81	125
D400HX0900	9,0	9	81	125
D400HX0910	9,1	9,1	81	125
D400HX0920	9,2	9,2	81	125
D400HX0930	9,3	9,3	81	125
D400HX0940	9,4	9,4	81	125
D400HX0950	9,5	9,5	81	125
D400HX0960	9,6	9,6	87	133
D400HX0970	9,7	9,7	87	133
D400HX0980	9,8	9,8	87	133
D400HX0990	9,9	9,9	87	133
D400HX1000	10,0	10	87	133
D400HX1010	10,1	10,1	87	133
D400HX1020	10,2	10,2	87	133
D400HX1030	10,3	10,3	87	133
D400HX1040	10,4	10,4	87	133
D400HX1050	10,5	10,5	87	133
D400HX1060	10,6	10,6	87	133

Bestell Nr. Order no. Référence	d ₁ mm	d ₂ mm	l ₁ h6	l ₂ mm
D400HX1070	10,7	10,7	94	142
D400HX1080	10,8	10,8	94	142
D400HX1090	10,9	10,9	94	142
D400HX1100	11,0	11	94	142
D400HX1110	11,1	11,1	94	142
D400HX1120	11,2	11,2	94	142
D400HX1130	11,3	11,3	94	142
D400HX1140	11,4	11,4	94	142
D400HX1150	11,5	11,5	94	142
D400HX1160	11,6	11,6	94	142
D400HX1170	11,7	11,7	94	142
D400HX1180	11,8	11,8	94	142
D400HX1190	11,9	11,9	101	151
D400HX1200	12,0	12	101	151
D400HX1210	12,1	12,1	101	151
D400HX1220	12,2	12,2	101	151
D400HX1230	12,3	12,3	101	151
D400HX1240	12,4	12,4	101	151
D400HX1250	12,5	12,5	101	151
D400HX1260	12,6	12,6	101	151
D400HX1270	12,7	12,7	101	151
D400HX1280	12,8	12,8	101	151
D400HX1290	12,9	12,9	101	151
D400HX1300	13,0	13	101	151

Schnittdaten

Cutting data

Données de coupe

Materialgruppen Material groups Groupes matières	Vc m/min	f mm/U Ø 0,1-2,99	f mm/U Ø 3,0-5,99	f mm/U Ø 6,0-9,99	f mm/U Ø 10,0-15,99	f mm/U Ø 16,0-20,0
P Legierter Stahl <500 N/mm Alloyed steel <500 N/mm Acier allié <500 N/mm	40-60	0,030-0,080	0,090-0,180	0,180-0,250	0,250-0,350	0,350-0,550
Legierter Stahl <700 N/mm Alloyed steel <700 N/mm Acier allié <700 N/mm	35-45	0,030-0,080	0,090-0,180	0,180-0,250	0,250-0,350	0,350-0,550
Legierter Stahl <850 N/mm Alloyed steel <850 N/mm Acier allié <850 N/mm	25-35	0,030-0,080	0,090-0,180	0,180-0,250	0,250-0,350	0,350-0,550
Legierter Stahl <1000 N/mm Alloyed steel <1000 N/mm Acier allié <1000 N/mm	10-20	0,020-0,060	0,060-0,90	0,090-0,150	0,150-0,220	0,220-0,250
Legierter Stahl <1400 N/mm Alloyed steel <1400 N/mm Acier allié <1400 N/mm	8-12	0,020-0,060	0,060-0,90	0,090-0,150	0,150-0,220	0,220-0,250
M Edelstahl Stainless Steel Acier inoxydable	8-12	0,020-0,030	0,030-0,060	0,060-0,110	0,110-0,140	0,140-0,200
K Gusseisen Cast Iron Fonte	30-35	0,030-0,080	0,090-0,180	0,180-0,250	0,250-0,350	0,50-0,550
N Kupfer Copper Cuivre	80-100	0,030-0,080	0,090-0,180	0,180-0,250	0,250-0,350	0,50-0,550
S Titanium Titanium Titanium	5-8	0,020-0,030	0,030-0,060	0,060-0,110	0,110-0,140	0,140-0,200



HSSE-Spiralbohrer Satz DIN 338 - 130°

HSSE-twist set DIN 338 drill - 130°
HSSE-forets set DIN 338 - 130°

Besonders robust und stabil durch verstärkte Kerndicke. Profilgeschliffen, mit hoher Rundlaufgenauigkeit.

Particularly robust and strong due to strengthened core. Profile ground, with high concentricity.

Particulièrement rigides et résistants grâce à l'âme renforcée. Taillés avec une grande précision de concentricité.



Bestell Nr.
Order no.
Référence

SET.D40019

Satz beinhaltet
Set consist of
Set composé

1 - 10mm
19 Stück | pieces | pièce
0,5 steigend | rising | croissant



Bestell Nr.
Order no.
Référence

SET.D40025

Satz beinhaltet
Set consist of
Set composé

1 - 13mm
25 Stück | pieces | pièce
0,5 steigend | rising | croissant



Bestell Nr.
Order no.
Référence

SET.D40024

Satz beinhaltet
Set consist of
Set composé

1 - 10,5mm
24 Stück | pieces | pièce
0,5 steigend | rising | croissant + Ø3,5 + 4,2 + 6,8 + 10,2

HSSE-twist set DIN 338 drill - 130°
 HSSE-forets set DIN 338 - 130°



Bestell Nr. Order no. Référence	Satz beinhaltet Set consist of Set composé
SET.D40041	6 - 10mm 41 Stück pieces pièce 0,1 steigend rising croissant



Bestell Nr. Order no. Référence	Satz beinhaltet Set consist of Set composé
SET.D40050	1 - 5,9mm 50 Stück pieces pièce 0,1 steigend rising croissant

HSSE - Kegelsenker 90°

HSSE - countersink 90°
 HSSE - fraise à chanfreiner 90°

Alle Senker mit 3 Schneiden, radial hinterschliffen.
 Countersink with 3 cutting edges, radially relief ground.
 Toutes les fraises ont 3 dents, à dépouille radiale.

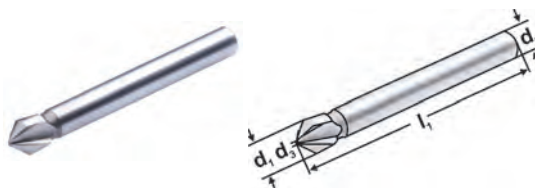

Bestell Nr. Order no. Référence	$d_1 \pm 0,05$	d_3	l_1	$d_2 h9$
DS601.0430	4,30	1,30	40,00	4,00
DS601.0500	5,00	1,30	40,00	4,00
DS601.0530	5,30	1,30	40,00	4,00
DS601.0580	5,80	1,30	45,00	5,00
DS601.0600	6,00	1,30	45,00	5,00
DS601.0630	6,30	1,30	45,00	5,00
DS601.0700	7,00	1,60	50,00	6,00
DS601.0730	7,30	1,60	50,00	6,00
DS601.0800	8,00	1,80	50,00	6,00
DS601.0830	8,30	1,80	50,00	6,00
DS601.0900	9,00	2,00	50,00	6,00
DS601.0940	9,40	2,00	50,00	6,00



VHM Hochleistungsbohrer 3xD

Solid carbide high performance drills 3xD
Forets en carbure a haute performance 3xD

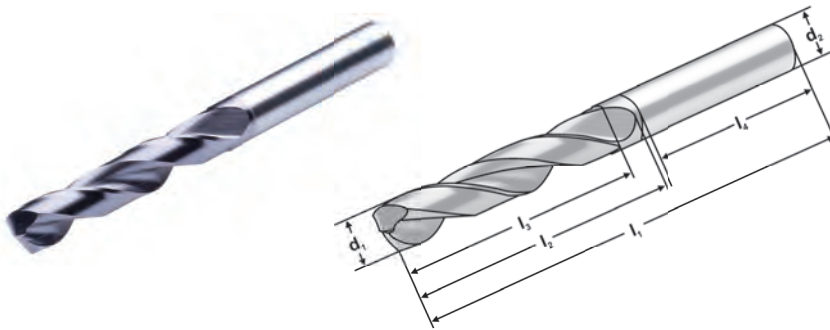

AITiCrN HX	3xD
2	MG Carbide
140°	

Einsatzgebiete:

Hochleistungsbohren auf CNC-Maschinen und Bearbeitungszentren für höchste Ansprüche an Wirtschaftlichkeit und Bohrungsqualität. Bohren von Stahl, Stahlguss, Grauguss, Temporguss, Chrom- und Nickelwerkstoffen, hochwarmfesten Stählen, Titan- und Titanlegierungen, NE-Metallen, Graphit und Kunststoffen.

P	H	M	K	N	S
●	●	○	●	○	○

Application:

High performance drilling on CNC machines and machining centers for highest bore hole quality and economical output. For drilling of steel, steel casting, gray cast iron, malleable cast iron, Cr-Ni-steels, heat resisting steel, titanium and titanium-alloys, non-ferrous metals, graphite and plastics.

Applications:

Forage à haute performance sur des machines CNC et centres d'usinage pour plus d'efficacité et de qualité du trou. Perçage d'acier, d'acier moulé, de fonte grise, de fonte malléable, de chrome et d'alliages de nickel, d'aciers à haute température, de titane et d'alliages de titane, des métaux non-ferreux, de graphite et des matières plastiques.

Bestell Nr. Order no. Référence	d ₁	d ₂ h6	l ₁	l ₂	l ₃	l ₄
D300.0300	3,00	6	62	20	14	36
D300.0310	3,10	6	62	20	14	36
D300.0320	3,20	6	62	20	14	36
D300.0325	3,25	6	62	20	14	36
D300.0330	3,30	6	62	20	14	36
D300.0340	3,40	6	62	20	14	36
D300.0350	3,50	6	62	20	14	36
D300.0360	3,60	6	62	20	14	36
D300.0370	3,70	6	62	20	14	36
D300.0380	3,80	6	66	24	17	36
D300.0390	3,90	6	66	24	17	36
D300.0400	4,00	6	66	24	17	36
D300.0410	4,10	6	66	24	17	36
D300.0420	4,20	6	66	24	17	36
D300.0430	4,30	6	66	24	17	36
D300.0440	4,40	6	66	24	17	36
D300.0450	4,50	6	66	24	17	36
D300.0460	4,60	6	66	24	17	36
D300.0465	4,65	6	66	24	17	36
D300.0470	4,70	6	66	24	17	36
D300.0480	4,80	6	66	28	20	36
D300.0490	4,90	6	66	28	20	36
D300.0500	5,00	6	66	28	20	36
D300.0510	5,10	6	66	28	20	36
D300.0520	5,20	6	66	28	20	36
D300.0530	5,30	6	66	28	20	36
D300.0540	5,40	6	66	28	20	36
D300.0550	5,50	6	66	28	20	36
D300.0555	5,55	6	66	28	20	36
D300.0560	5,60	6	66	28	20	36
D300.0570	5,70	6	66	28	20	36

Bestell Nr. Order no. Référence	d ₁	d ₂ h6	l ₁	l ₂	l ₃	l ₄
D300.0580	5,80	6	66	28	20	36
D300.0590	5,90	6	66	28	20	36
D300.0600	6,00	6	66	28	20	36
D300.0610	6,10	8	79	34	24	36
D300.0620	6,20	8	79	34	24	36
D300.0630	6,30	8	79	34	24	36
D300.0640	6,40	8	79	34	24	36
D300.0650	6,50	8	79	34	24	36
D300.0660	6,60	8	79	34	24	36
D300.0670	6,70	8	79	34	24	36
D300.0675	6,75	8	79	34	24	36
D300.0680	6,80	8	79	34	24	36
D300.0690	6,90	8	79	34	24	36
D300.0700	7,00	8	79	34	24	36
D300.0710	7,10	8	79	41	29	36
D300.0720	7,20	8	79	41	29	36
D300.0730	7,30	8	79	41	29	36
D300.0740	7,40	8	79	41	29	36
D300.0750	7,50	8	79	41	29	36
D300.0760	7,60	8	79	41	29	36
D300.0770	7,70	8	79	41	29	36
D300.0780	7,80	8	79	41	29	36
D300.0790	7,90	8	79	41	29	36
D300.0800	8,00	8	79	41	29	36
D300.0810	8,10	10	89	47	35	40
D300.0820	8,20	10	89	47	35	40
D300.0830	8,30	10	89	47	35	40
D300.0840	8,40	10	89	47	35	40
D300.0850	8,50	10	89	47	35	40
D300.0860	8,60	10	89	47	35	40
D300.0870	8,70	10	89	47	35	40
D300.0880	8,80	10	89	47	35	40
D300.0890	8,90	10	89	47	35	40
D300.0900	9,00	10	89	47	35	40
D300.0910	9,10	10	89	47	35	40
D300.0920	9,20	10	89	47	35	40
D300.0930	9,30	10	89	47	35	40
D300.0940	9,40	10	89	47	35	40
D300.0950	9,50	10	89	47	35	40
D300.0960	9,60	10	89	47	35	40
D300.0970	9,70	10	89	47	35	40
D300.0980	9,80	10	89	47	35	40
D300.0990	9,90	10	89	47	35	40
D300.1000	10,00	10	89	47	35	45
D300.1010	10,10	12	102	55	40	45
D300.1020	10,20	12	102	55	40	45
D300.1025	10,25	12	102	55	40	45
D300.1030	10,30	12	102	55	40	45
D300.1040	10,40	12	102	55	40	45
D300.1050	10,50	12	102	55	40	45
D300.1060	10,60	12	102	55	40	45

Bestell Nr. Order no. Référence	d ₁	d ₂ h6	l ₁	l ₂	l ₃	l ₄
D300.1070	10,70	12	102	55	40	45
D300.1080	10,80	12	102	55	40	45
D300.1090	10,90	12	102	55	40	45
D300.1100	11,00	12	102	55	40	45
D300.1110	11,10	12	102	55	40	45
D300.1120	11,20	12	102	55	40	45
D300.1130	11,30	12	102	55	40	45
D300.1140	11,40	12	102	55	40	45
D300.1150	11,50	12	102	55	40	45
D300.1160	11,60	12	102	55	40	45
D300.1170	11,70	12	102	55	40	45
D300.1180	11,80	12	102	55	40	45
D300.1190	11,90	12	102	55	40	45
D300.1200	12,00	12	102	55	40	45
D300.1220	12,20	14	107	60	43	45
D300.1225	12,25	14	107	60	43	45
D300.1230	12,30	14	107	60	43	45
D300.1250	12,50	14	107	60	43	45
D300.1270	12,70	14	107	60	43	45
D300.1275	12,75	14	107	60	43	45
D300.1280	12,80	14	107	60	43	45
D300.1300	13,00	14	107	60	43	45
D300.1310	13,10	14	107	60	43	45
D300.1350	13,50	14	107	60	43	45
D300.1380	13,80	14	107	60	43	45
D300.1400	14,00	14	107	60	43	45
D300.1425	14,25	16	115	65	45	48
D300.1430	14,30	16	115	65	45	48
D300.1450	14,50	16	115	65	45	48
D300.1475	14,75	16	115	65	45	48
D300.1480	14,80	16	115	65	45	48
D300.1500	15,00	16	115	65	45	48
D300.1510	15,10	16	115	65	45	48
D300.1550	15,50	16	115	65	45	48
D300.1580	15,80	16	115	65	45	48
D300.1600	16,00	16	115	65	45	48
D300.1650	16,50	18	123	73	51	48
D300.1675	16,75	18	123	73	51	48
D300.1680	16,80	18	123	73	51	48
D300.1700	17,00	18	123	73	51	48
D300.1750	17,50	18	123	73	51	48
D300.1780	17,80	18	123	73	51	48
D300.1800	18,00	18	123	73	51	48
D300.1850	18,50	20	131	79	55	50
D300.1880	18,80	20	131	79	55	50
D300.1900	19,00	20	131	79	55	50
D300.1950	19,50	20	131	79	55	50
D300.1980	19,80	20	131	79	55	50
D300.2000	20,00	20	131	79	55	50



Cutting data 3xD
Données de coupe 3xD

Materialgruppen Material groups Groupes matières	Vc (mm)	P Wenig legierter Stahl Low-alloyed steel Acier faible allié		H Stahl 30-38HRC Steel 30-38HRC Acier 30-38HRC		H Stahl 38-48 HRC Steel 38-48 HRC Acier 38-48 HRC		M Edelstahl Stainless Steel Acier inoxydable		K Gussisen Cast Iron Fonte		N Aluminium Aluminium Aluminium		N Hitzebeständiger Stahl Heat resistant steel Acier thermostable	
		"n (min-1)"	"f (mm/r)"	"n (min-1)"	"f (mm/r)"	"n (min-1)"	"f (mm/r)"	"n (min-1)"	"f (mm/r)"	"n (min-1)"	"f (mm/r)"	"n (min-1)"	"f (mm/r)"	"n (min-1)"	"f (mm/r)"
2	14000	"0,06-0,08"	"0,10-0,15"	14000	"0,06-0,08"	9500	"0,06-0,08"	9500	"0,02-0,05"	14000	"0,06-0,08"	16000	"0,06-0,08"	3200	"0,02-0,04"
3	9500	"0,09-0,12"	"0,10-0,15"	9500	"0,09-0,12"	6300	"0,09-0,12"	3700	"0,03-0,07"	9500	"0,09-0,12"	10600	"0,09-0,12"	2100	"0,03-0,06"
4	7000	"0,10-0,15"	"0,10-0,15"	7000	"0,10-0,15"	4700	"0,10-0,15"	2700	"0,04-0,08"	7000	"0,10-0,15"	8000	"0,10-0,15"	1600	"0,04-0,07"
5	5700	"0,12-0,18"	"0,12-0,18"	5700	"0,12-0,18"	3800	"0,12-0,18"	2200	"0,05-0,10"	5700	"0,12-0,18"	6400	"0,12-0,18"	1250	"0,05-0,09"
6	4700	"0,14-0,20"	"0,14-0,20"	4700	"0,14-0,20"	3100	"0,14-0,20"	1850	"0,06-0,12"	4700	"0,14-0,20"	5300	"0,14-0,20"	1050	"0,06-0,11"
8	3600	"0,16-0,24"	"0,16-0,24"	3600	"0,16-0,24"	2400	"0,16-0,24"	1400	"0,08-0,16"	3600	"0,16-0,24"	4000	"0,16-0,24"	800	"0,08-0,14"
10	2800	"0,18-0,27"	"0,18-0,27"	2800	"0,18-0,27"	1900	"0,18-0,27"	1100	"0,10-0,18"	2800	"0,18-0,27"	3200	"0,18-0,27"	600	"0,10-0,16"
12	2400	"0,20-0,30"	"0,20-0,30"	2400	"0,20-0,30"	1600	"0,20-0,30"	930	"0,12-0,20"	2400	"0,20-0,30"	2700	"0,20-0,30"	500	"0,12-0,18"
14	2100	"0,22-0,35"	"0,22-0,35"	2100	"0,22-0,35"	1400	"0,22-0,35"	800	"0,13-0,22"	2100	"0,22-0,35"	2300	"0,22-0,35"	450	"0,13-0,20"
16	1800	"0,25-0,36"	"0,25-0,36"	1800	"0,25-0,36"	1200	"0,25-0,36"	700	"0,14-0,25"	1800	"0,25-0,36"	2000	"0,25-0,36"	400	"0,14-0,23"
18	1600	"0,28-0,38"	"0,28-0,38"	1600	"0,28-0,38"	1100	"0,28-0,38"	620	"0,15-0,28"	1600	"0,28-0,38"	1800	"0,28-0,38"	350	"0,15-0,25"
20	1400	"0,30-0,40"	"0,30-0,40"	1400	"0,30-0,40"	950	"0,30-0,40"	550	"0,16-0,30"	1400	"0,30-0,40"	1600	"0,30-0,40"	320	"0,16-0,28"

1. Beim ersten Einsatz 90% der empfohlenen Schnittgeschwindigkeit oder 85% des Vorschubes wählen. Bei stabiler Bearbeitung die Schnittdaten entsprechend erhöhen.
2. Die obigen Schnittdatenempfehlungen basieren auf dem Einsatz von Emulsion.
3. Keine defekte Werkzeugaufnahme wählen. Die Rundlaufgenauigkeit muss unter 0,02mm liegen.
4. Die obigen Schnittdaten sind für Bohrungstiefen unter 5xD ausgelegt.

1. When the tool is used for the first time, please make a test cutting with 90% of cutting speed or 85% feed rate mentioned above. If the cutting conditions remain stable, gradually increase the cutting speed and feed rate.
2. The cutting conditions above are for drilling with emulsion.
3. Use a collet without any defect or dust. The radial run-out of drill must be under 0.02mm.
4. These conditions above are for cutting depth under 5xD.

1. La première fois que vous utilisez sélectionner 90% de la vitesse de coupe recommandée ou 85% de l'alimentation. Avec stable traitement des données de coupe augmentent en conséquence.
2. Les recommandations de données de coupe ci-dessus sont basées sur l'utilisation de l'émulsion.
3. Ne composez jamais un porte-outil défectueux. La concentricité doit être inférieure à 0,02 mm.
4. Les données ci-dessus en coupe sont conçus pour des profondeurs de forage sous 5xD.



VHM Hochleistungsbohrer 3xD mit Innenkühlung

Solid carbide high performance drills 3xD with internal coolant
Forets en carbure a haute performance 3xD avec arrosage centrale

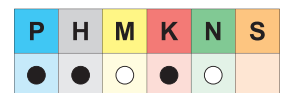
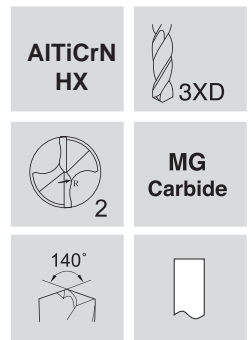
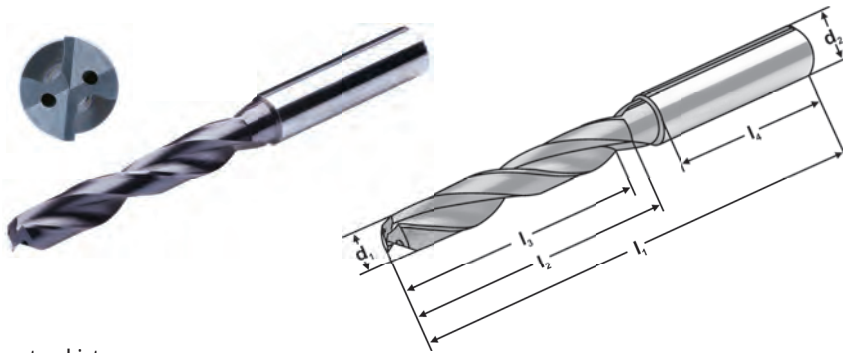

Einsatzgebiete:

Hochleistungsbohren auf CNC-Maschinen und Bearbeitungszentren für höchste Ansprüche an Wirtschaftlichkeit und Bohrungsqualität. Bohren von Stahl, Stahlguss, Grauguss, Temperguss, Chrom- und Nickelwerkstoffen, hochwärmfesten Stählen, Titan- und Titanlegierungen, NE-Metallen, Graphit und Kunststoffen.

Application:

High performance drilling on CNC machines and machining centers for highest bore hole quality and economical output. For drilling of steel, steel casting, gray cast iron, malleable cast iron, Cr-Ni-steels, heat resisting steel, titanium and titanium-alloys, non-ferrous metals, graphite and plastics.

Applications:

Forage à haute performance sur des machines CNC et centres d'usinage pour plus d'efficacité et de qualité du trou. Perçage d'acier, d'acier moulé, de fonte grise, de fonte malléable, de chrome et d'alliages de nickel, d'aciers à haute température, de titane et d'alliages de titane, des métaux non-ferreux, de graphite et des matières plastiques.

Bestell Nr. Order no. Référence	d ₁	d ₂ h6	l ₁	l ₂	l ₃	l ₄
D301.0300	3,00	6	62	20	14	36
D301.0310	3,10	6	62	20	14	36
D301.0320	3,20	6	62	20	14	36
D301.0325	3,25	6	62	20	14	36
D301.0330	3,30	6	62	20	14	36
D301.0340	3,40	6	62	20	14	36
D301.0350	3,50	6	62	20	14	36
D301.0360	3,60	6	62	20	14	36
D301.0370	3,70	6	62	20	14	36
D301.0380	3,80	6	66	24	17	36
D301.0390	3,90	6	66	24	17	36
D301.0400	4,00	6	66	24	17	36
D301.0410	4,10	6	66	24	17	36
D301.0420	4,20	6	66	24	17	36
D301.0430	4,30	6	66	24	17	36
D301.0440	4,40	6	66	24	17	36
D301.0450	4,50	6	66	24	17	36
D301.0460	4,60	6	66	24	17	36
D301.0465	4,65	6	66	24	17	36
D301.0470	4,70	6	66	24	17	36
D301.0480	4,80	6	66	28	20	36
D301.0490	4,90	6	66	28	20	36
D301.0500	5,00	6	66	28	20	36
D301.0510	5,10	6	66	28	20	36
D301.0520	5,20	6	66	28	20	36
D301.0530	5,30	6	66	28	20	36
D301.0540	5,40	6	66	28	20	36
D301.0550	5,50	6	66	28	20	36
D301.0555	5,55	6	66	28	20	36
D301.0560	5,60	6	66	28	20	36
D301.0570	5,70	6	66	28	20	36

Bestell Nr. Order no. Référence	d ₁	d ₂ h6	l ₁	l ₂	l ₃	l ₄
D301.0580	5,80	6	66	28	20	36
D301.0590	5,90	6	66	28	20	36
D301.0600	6,00	6	66	28	20	36
D301.0610	6,10	8	79	34	24	36
D301.0620	6,20	8	79	34	24	36
D301.0630	6,30	8	79	34	24	36
D301.0640	6,40	8	79	34	24	36
D301.0650	6,50	8	79	34	24	36
D301.0660	6,60	8	79	34	24	36
D301.0670	6,70	8	79	34	24	36
D301.0675	6,75	8	79	34	24	36
D301.0680	6,80	8	79	34	24	36
D301.0690	6,90	8	79	34	24	36
D301.0700	7,00	8	79	34	24	36
D301.0710	7,10	8	79	34	29	36
D301.0720	7,20	8	79	34	29	36
D301.0730	7,30	8	79	34	29	36
D301.0740	7,40	8	79	34	29	36
D301.0750	7,50	8	79	34	29	36
D301.0760	7,60	8	79	34	29	36
D301.0770	7,70	8	79	34	29	36
D301.0780	7,80	8	79	34	29	36
D301.0790	7,90	8	79	34	29	36
D301.0800	8,00	8	79	34	29	36
D301.0810	8,10	10	89	47	35	40
D301.0820	8,20	10	89	47	35	40
D301.0830	8,30	10	89	47	35	40
D301.0840	8,40	10	89	47	35	40
D301.0850	8,50	10	89	47	35	40
D301.0860	8,60	10	89	47	35	40
D301.0870	8,70	10	89	47	35	40
D301.0880	8,80	10	89	47	35	40
D301.0890	8,90	10	89	47	35	40
D301.0900	9,00	10	89	47	35	40
D301.0910	9,10	10	89	47	35	40
D301.0920	9,20	10	89	47	35	40
D301.0930	9,30	10	89	47	35	40
D301.0940	9,40	10	89	47	35	40
D301.0950	9,50	10	89	47	35	40
D301.0960	9,60	10	89	47	35	40
D301.0970	9,70	10	89	47	35	40
D301.0980	9,80	10	89	47	35	40
D301.0990	9,90	10	89	47	35	40
D301.1000	10,00	10	89	47	35	45
D301.1010	10,10	12	102	55	40	45
D301.1020	10,20	12	102	55	40	45
D301.1025	10,25	12	102	55	40	45
D301.1030	10,30	12	102	55	40	45
D301.1040	10,40	12	102	55	40	45
D301.1050	10,50	12	102	55	40	45
D301.1060	10,60	12	102	55	40	45

Bestell Nr. Order no. Référence	d ₁	d ₂ h6	l ₁	l ₂	l ₃	l ₄
D301.1070	10,70	12	102	55	40	45
D301.1080	10,80	12	102	55	40	45
D301.1090	10,90	12	102	55	40	45
D301.1100	11,00	12	102	55	40	45
D301.1110	11,10	12	102	55	40	45
D301.1120	11,20	12	102	55	40	45
D301.1130	11,30	12	102	55	40	45
D301.1140	11,40	12	102	55	40	45
D301.1150	11,50	12	102	55	40	45
D301.1160	11,60	12	102	55	40	45
D301.1170	11,70	12	102	55	40	45
D301.1180	11,80	12	102	55	40	45
D301.1190	11,90	12	102	55	40	45
D301.1200	12,00	12	102	55	40	45
D301.1225	12,25	14	107	60	43	45
D301.1230	12,30	14	107	60	43	45
D301.1250	12,50	14	107	60	43	45
D301.1270	12,70	14	107	60	43	45
D301.1275	12,75	14	107	60	43	45
D301.1280	12,80	14	107	60	43	45
D301.1300	13,00	14	107	60	43	45
D301.1310	13,10	14	107	60	43	45
D301.1350	13,50	14	107	60	43	45
D301.1380	13,80	14	107	60	43	45
D301.1400	14,00	14	107	60	43	45
D301.1420	14,20	16	115	65	45	48
D301.1425	14,25	16	115	65	45	48
D301.1430	14,30	16	115	65	45	48
D301.1450	14,50	16	115	65	45	48
D301.1475	14,75	16	115	65	45	48
D301.1480	14,80	16	115	65	45	48
D301.1500	15,00	16	115	65	45	48
D301.1510	15,10	16	115	65	45	48
D301.1550	15,50	16	115	65	45	48
D301.1580	15,80	16	115	65	45	48
D301.1600	16,00	16	115	65	45	48
D301.1650	16,50	18	123	73	51	48
D301.1675	16,75	18	123	73	51	48
D301.1680	16,80	18	123	73	51	48
D301.1700	17,00	18	123	73	51	48
D301.1750	17,50	18	123	73	51	48
D301.1780	17,80	18	123	73	51	48
D301.1800	18,00	18	123	73	51	48
D301.1850	18,50	20	131	79	55	50
D301.1880	18,80	20	131	79	55	50
D301.1900	19,00	20	131	79	55	50
D301.1950	19,50	20	131	79	55	50
D301.1980	19,80	20	131	79	55	50
D301.2000	20,00	20	131	79	55	50

Cutting data 3xD

Données de coupe 3xD

Materialgruppen Material groups Groupes matières	Vc "0 (mm)"	P Wenig legierter Stahl Low-alloyed steel Acier faible allié		H Stahl 30-38HRC Steel 30-38HRC Acier 30-38HRC		H Stahl 38-48 HRC Steel 38-48 HRC Acier 38-48 HRC		M Edelstahl Stainless Steel Acier inoxydable		K Guss Eisen Cast Iron Fonte		N Aluminium Aluminium Aluminium		N Hitzebeständiger Stahl Heat resistant steel Acier thermostable	
		"n (min-1)"	"f (mm/r)"	"n (min-1)"	"f (mm/r)"	"n (min-1)"	"f (mm/r)"	"n (min-1)"	"f (mm/r)"	"n (min-1)"	"f (mm/r)"	"n (min-1)"	"f (mm/r)"	"n (min-1)"	"f (mm/r)"
3	12700	"0,09- 0,12"	"0,09- 0,12"	12700	"0,09- 0,12"	7400	"0,09- 0,12"	6300	"0,03- 0,07"	12700	"0,09- 0,12"	9500	"0,09- 0,12"	2100	"0,03- 0,06"
4	9600	"0,10- 0,15"	"0,10- 0,15"	9600	"0,10- 0,15"	5600	"0,10- 0,15"	4700	"0,04- 0,08"	9600	"0,10- 0,15"	7000	"0,10- 0,15"	1600	"0,04- 0,07"
5	7600	"0,12- 0,18"	"0,12- 0,18"	7600	"0,12- 0,18"	4500	"0,12- 0,18"	3800	"0,05- 0,10"	7600	"0,12- 0,18"	5700	"0,12- 0,18"	1250	"0,05- 0,09"
6	6400	"0,14- 0,20"	"0,14- 0,20"	6400	"0,14- 0,20"	3700	"0,14- 0,20"	3200	"0,06- 0,12"	6400	"0,14- 0,20"	4700	"0,14- 0,20"	1050	"0,06- 0,11"
8	4800	"0,16- 0,24"	"0,16- 0,24"	4800	"0,16- 0,24"	2800	"0,16- 0,24"	2400	"0,08- 0,16"	4800	"0,16- 0,24"	3600	"0,16- 0,24"	800	"0,08- 0,14"
10	3800	"0,18- 0,27"	"0,18- 0,27"	3800	"0,18- 0,27"	2200	"0,18- 0,27"	1900	"0,10- 0,18"	3800	"0,18- 0,27"	2800	"0,18- 0,27"	600	"0,10- 0,16"
12	3200	"0,20- 0,30"	"0,20- 0,30"	3200	"0,20- 0,30"	1900	"0,20- 0,30"	1600	"0,12- 0,20"	3200	"0,20- 0,30"	2400	"0,20- 0,30"	500	"0,12- 0,18"
14	2700	"0,22- 0,35"	"0,22- 0,35"	2700	"0,22- 0,35"	1600	"0,22- 0,35"	1350	"0,13- 0,22"	2700	"0,22- 0,35"	2100	"0,22- 0,35"	450	"0,13- 0,20"
16	2400	"0,25- 0,36"	"0,25- 0,36"	2400	"0,25- 0,36"	1400	"0,25- 0,36"	1200	"0,14- 0,25"	2400	"0,25- 0,36"	1800	"0,25- 0,36"	400	"0,14- 0,23"
18	2100	"0,28- 0,38"	"0,28- 0,38"	2100	"0,28- 0,38"	1200	"0,28- 0,38"	1050	"0,15- 0,28"	2100	"0,28- 0,38"	1600	"0,28- 0,38"	350	"0,15- 0,25"
20	1900	"0,30- 0,40"	"0,30- 0,40"	1900	"0,30- 0,40"	1100	"0,30- 0,40"	950	"0,16- 0,30"	1900	"0,30- 0,40"	1400	"0,30- 0,40"	320	"0,16- 0,28"

1. Beim ersten Einsatz 90% der empfohlenen Schnittgeschwindigkeit oder 85% des Vorschubes wählen. Bei stabiler Bearbeitung die Schnittdaten entsprechend erhöhen.
2. Die obigen Schnittdatenempfehlungen basieren auf dem Einsatz von Emulsion.
3. Keine defekte Werkzeugaufnahme wählen. Die Rundlaufgenauigkeit muss unter 0,02mm liegen.
4. Die obigen Schnittdaten sind für Bohrungstiefen unter 5xD ausgelegt.

1. When the tool is used for the first time, please make a test cutting with 90% of cutting speed or 85% feed rate mentioned above. If the cutting conditions remain stable, gradually increase the cutting speed and feed rate.
2. The cutting conditions above are for drilling with emulsion.
3. Use a collet without any defect or dust. The radial run-out of drill must be under 0.02mm.
4. These conditions above are for cutting depth under 5xD.

1. La première fois que vous utilisez sélectionner 90% de la vitesse de coupe recommandée ou 85% de l'alimentation. Avec stable traitement des données de coupe augmentent en conséquence.
2. Les recommandations de données de coupe ci-dessus sont basées sur l'utilisation de l'émulsion.
3. Ne composez jamais un porte-outil défectueux.
La concentricité doit être inférieure à 0,02 mm.
4. Les données ci-dessus en coupe sont conçus pour des profondeurs de forage sous 5xD.



VHM Hochleistungsbohrer 3xD mit Innenkühlung und Weldon Fläche

Solid carbide high performance drills 3xD with internal coolant and weldon shank
Forets en carbure a haute performance 3xD avec arrosage centrale et face weldon

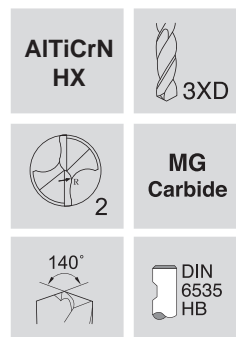
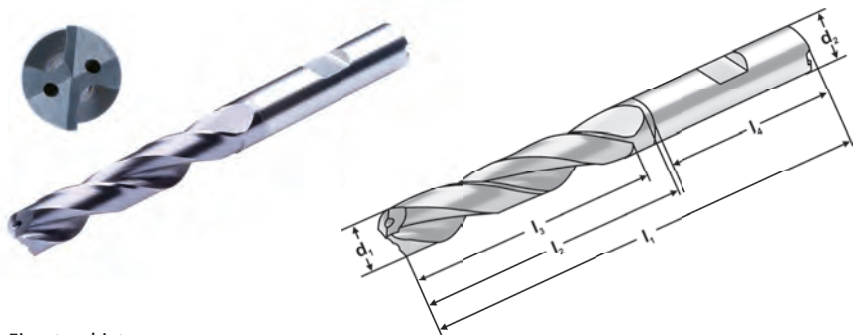

Einsatzgebiete:

Hochleistungsbohren auf CNC-Maschinen und Bearbeitungszentren für höchste Ansprüche an Wirtschaftlichkeit und Bohrungsqualität. Bohren von Stahl, Stahlguss, Grauguss, Temperguss, Chrom- und Nickelwerkstoffen, hochwarmfesten Stählen, Titan- und Titanlegierungen, NE-Metallen, Graphit und Kunststoffen.

Application:

High performance drilling on CNC machines and machining centers for highest bore hole quality and economical output. For drilling of steel, steel casting, gray cast iron, malleable cast iron, Cr-Ni-steels, heat resisting steel, titanium and titanium-alloys, non-ferrous metals, graphite and plastics.

Applications:

Forage à haute performance sur des machines CNC et centres d'usinage pour plus d'efficacité et de qualité du trou. Perçage d'acier, d'acier moulé, de fonte grise, de fonte malléable, de chrome et d'alliages de nickel, d'aciers à haute température, de titane et d'alliages de titane, des métaux non-ferreux, de graphite et des matières plastiques.

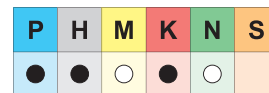

Bestell Nr. Order no. Référence	d ₁	d ₂ h6	l ₁	l ₂	l ₃	l ₄
D302.0300	3,00	6	62	20	14	36
D302.0310	3,10	6	62	20	14	36
D302.0320	3,20	6	62	20	14	36
D302.0325	3,25	6	62	20	14	36
D302.0330	3,30	6	62	20	14	36
D302.0340	3,40	6	62	20	14	36
D302.0350	3,50	6	62	20	14	36
D302.0360	3,60	6	62	20	14	36
D302.0370	3,70	6	62	20	14	36
D302.0380	3,80	6	66	24	17	36
D302.0390	3,90	6	66	24	17	36
D302.0400	4,00	6	66	24	17	36
D302.0410	4,10	6	66	24	17	36
D302.0420	4,20	6	66	24	17	36
D302.0430	4,30	6	66	24	17	36
D302.0440	4,40	6	66	24	17	36
D302.0450	4,50	6	66	24	17	36
D302.0460	4,60	6	66	24	17	36
D302.0465	4,65	6	66	24	17	36
D302.0470	4,70	6	66	24	17	36
D302.0480	4,80	6	66	28	20	36
D302.0490	4,90	6	66	28	20	36
D302.0500	5,00	6	66	28	20	36
D302.0510	5,10	6	66	28	20	36
D302.0520	5,20	6	66	28	20	36
D302.0530	5,30	6	66	28	20	36
D302.0540	5,40	6	66	28	20	36
D302.0550	5,50	6	66	28	20	36
D302.0555	5,55	6	66	28	20	36
D302.0560	5,60	6	66	28	20	36
D302.0570	5,70	6	66	28	20	36

Bestell Nr. Order no. Référence	d ₁	d ₂ h6	l ₁	l ₂	l ₃	l ₄
D302.0580	5,80	6	66	28	20	36
D302.0590	5,90	6	66	28	20	36
D302.0600	6,00	6	66	28	20	36
D302.0610	6,10	8	79	34	24	36
D302.0620	6,20	8	79	34	24	36
D302.0630	6,30	8	79	34	24	36
D302.0640	6,40	8	79	34	24	36
D302.0650	6,50	8	79	34	24	36
D302.0660	6,60	8	79	34	24	36
D302.0670	6,70	8	79	34	24	36
D302.0675	6,75	8	79	34	24	36
D302.0680	6,80	8	79	34	24	36
D302.0690	6,90	8	79	34	24	36
D302.0700	7,00	8	79	34	24	36
D302.0710	7,10	8	79	34	29	36
D302.0720	7,20	8	79	34	29	36
D302.0730	7,30	8	79	34	29	36
D302.0740	7,40	8	79	34	29	36
D302.0750	7,50	8	79	34	29	36
D302.0760	7,60	8	79	34	29	36
D302.0770	7,70	8	79	34	29	36
D302.0780	7,80	8	79	34	29	36
D302.0790	7,90	8	79	34	29	36
D302.0800	8,00	8	79	34	29	36
D302.0810	8,10	10	89	47	35	40
D302.0820	8,20	10	89	47	35	40
D302.0830	8,30	10	89	47	35	40
D302.0840	8,40	10	89	47	35	40
D302.0850	8,50	10	89	47	35	40
D302.0860	8,60	10	89	47	35	40
D302.0870	8,70	10	89	47	35	40
D302.0880	8,80	10	89	47	35	40
D302.0890	8,90	10	89	47	35	40
D302.0900	9,00	10	89	47	35	40
D302.0910	9,10	10	89	47	35	40
D302.0920	9,20	10	89	47	35	40
D302.0930	9,30	10	89	47	35	40
D302.0940	9,40	10	89	47	35	40
D302.0950	9,50	10	89	47	35	40
D302.0960	9,60	10	89	47	35	40
D302.0970	9,70	10	89	47	35	40
D302.0980	9,80	10	89	47	35	40
D302.0990	9,90	10	89	47	35	40
D302.1000	10,00	10	89	47	35	45
D302.1010	10,10	12	102	55	40	45
D302.1020	10,20	12	102	55	40	45
D302.1025	10,25	12	102	55	40	45
D302.1030	10,30	12	102	55	40	45
D302.1040	10,40	12	102	55	40	45
D302.1050	10,50	12	102	55	40	45
D302.1060	10,60	12	102	55	40	45

Bestell Nr. Order no. Référence	d ₁	d ₂ h6	l ₁	l ₂	l ₃	l ₄
D302.1070	10,70	12	102	55	40	45
D302.1080	10,80	12	102	55	40	45
D302.1090	10,90	12	102	55	40	45
D302.1100	11,00	12	102	55	40	45
D302.1110	11,10	12	102	55	40	45
D302.1120	11,20	12	102	55	40	45
D302.1130	11,30	12	102	55	40	45
D302.1140	11,40	12	102	55	40	45
D302.1150	11,50	12	102	55	40	45
D302.1160	11,60	12	102	55	40	45
D302.1170	11,70	12	102	55	40	45
D302.1180	11,80	12	102	55	40	45
D302.1190	11,90	12	102	55	40	45
D302.1200	12,00	12	102	55	40	45
D302.1225	12,25	14	107	60	43	45
D302.1230	12,30	14	107	60	43	45
D302.1250	12,50	14	107	60	43	45
D302.1270	12,70	14	107	60	43	45
D302.1275	12,75	14	107	60	43	45
D302.1280	12,80	14	107	60	43	45
D302.1300	13,00	14	107	60	43	45
D302.1310	13,10	14	107	60	43	45
D302.1350	13,50	14	107	60	43	45
D302.1380	13,80	14	107	60	43	45
D302.1400	14,00	14	107	60	43	45
D302.1420	14,20	16	115	65	45	48
D302.1430	14,30	16	115	65	45	48
D302.1450	14,50	16	115	65	45	48
D302.1480	14,80	16	115	65	45	48
D302.1500	15,00	16	115	65	45	48
D302.1510	15,10	16	115	65	45	48
D302.1550	15,50	16	115	65	45	48
D302.1580	15,80	16	115	65	45	48
D302.1600	16,00	16	115	65	45	48
D302.1650	16,50	18	123	73	51	48
D302.1675	16,75	18	123	73	51	48
D302.1680	16,80	18	123	73	51	48
D302.1700	17,00	18	123	73	51	48
D302.1750	17,50	18	123	73	51	48
D302.1780	17,80	18	123	73	51	48
D302.1800	18,00	18	123	73	51	48
D302.1850	18,50	20	131	79	55	50
D302.1880	18,80	20	131	79	55	50
D302.1900	19,00	20	131	79	55	50
D302.1950	19,50	20	131	79	55	50
D302.1980	19,80	20	131	79	55	50
D302.2000	20,00	20	131	79	55	50

Cutting data 3xD

Données de coupe 3xD

Materialgruppen Material groups Groupes matières	Vc "0 (mm)"	P Wenig legierter Stahl Low-alloyed steel Acier faible allié		H Stahl 30-38HRC Steel 30-38HRC Acier 30-38HRC		M Edelstahl Stainless Steel Acier inoxydable		K Güßeisen Cast Iron Fonte		N Graphit Graphite Graphite		Aluminium Aluminium Aluminium		Hitzebeständiger Stahl Heat resistant steel Acier thermostable	
		"n (min-1)"	"f (mm/r)"	"n (min-1)"	"f (mm/r)"	"n (min-1)"	"f (mm/r)"	"n (min-1)"	"f (mm/r)"	"n (min-1)"	"f (mm/r)"	"n (min-1)"	"f (mm/r)"	"n (min-1)"	"f (mm/r)"
3	3	12700	"0,09~ 0,12"	12700	"0,09~ 0,12"	6300	"0,03~ 0,07"	12700	"0,09~ 0,12"	9500	"0,09~ 0,12"	15000	"0,09~ 0,12"	2100	"0,03~ 0,06"
4	4	9600	"0,10~ 0,15"	9600	"0,10~ 0,15"	4700	"0,04~ 0,08"	9600	"0,10~ 0,15"	7000	"0,10~ 0,15"	11100	"0,10~ 0,15"	1600	"0,04~ 0,07"
5	5	7600	"0,12~ 0,18"	7600	"0,12~ 0,18"	3800	"0,05~ 0,10"	7600	"0,12~ 0,18"	5700	"0,12~ 0,18"	9000	"0,12~ 0,18"	1250	"0,05~ 0,09"
6	6	6400	"0,14~ 0,20"	6400	"0,14~ 0,20"	3200	"0,06~ 0,12"	6400	"0,14~ 0,20"	4700	"0,14~ 0,20"	7400	"0,14~ 0,20"	1050	"0,06~ 0,11"
8	8	4800	"0,16~ 0,24"	4800	"0,16~ 0,24"	2400	"0,08~ 0,16"	4800	"0,16~ 0,24"	3600	"0,16~ 0,24"	5600	"0,16~ 0,24"	800	"0,08~ 0,14"
10	10	3800	"0,18~ 0,27"	3800	"0,18~ 0,27"	1900	"0,10~ 0,18"	3800	"0,18~ 0,27"	2800	"0,18~ 0,27"	4500	"0,18~ 0,27"	600	"0,10~ 0,16"
12	12	3200	"0,20~ 0,30"	3200	"0,20~ 0,30"	1600	"0,12~ 0,20"	3200	"0,20~ 0,30"	2400	"0,20~ 0,30"	3700	"0,20~ 0,30"	500	"0,12~ 0,18"
14	14	2700	"0,22~ 0,35"	2700	"0,22~ 0,35"	1350	"0,13~ 0,22"	2700	"0,22~ 0,35"	2100	"0,22~ 0,35"	3200	"0,22~ 0,35"	450	"0,13~ 0,20"
16	16	2400	"0,25~ 0,36"	2400	"0,25~ 0,36"	1200	"0,14~ 0,25"	2400	"0,25~ 0,36"	1800	"0,25~ 0,36"	2800	"0,25~ 0,36"	400	"0,14~ 0,23"
18	18	2100	"0,28~ 0,38"	2100	"0,28~ 0,38"	1050	"0,15~ 0,28"	2100	"0,28~ 0,38"	1600	"0,28~ 0,38"	2500	"0,28~ 0,38"	350	"0,15~ 0,25"
20	20	1900	"0,30~ 0,40"	1900	"0,30~ 0,40"	950	"0,16~ 0,30"	1900	"0,30~ 0,40"	1400	"0,30~ 0,40"	2300	"0,30~ 0,40"	320	"0,16~ 0,28"

1. Beim ersten Einsatz 90% der empfohlenen Schnittgeschwindigkeit oder 85% des Vorschubes wählen. Bei stabiler Bearbeitung die Schnittdaten entsprechend erhöhen.
2. Die obigen Schnittdatenempfehlungen basieren auf dem Einsatz von Emulsion.
3. Keine defekte Werkzeugaufnahme wählen. Die Rundlaufgenauigkeit muss unter 0,02mm liegen.
4. Die obigen Schnittdaten sind für Bohrungstiefen unter 5xD ausgelegt.

1. When the tool is used for the first time, please make a test cutting with 90% of cutting speed or 85% feed rate mentioned above. If the cutting conditions remain stable, gradually increase the cutting speed and feed rate.
2. The cutting conditions above are for drilling with emulsion.
3. Use a collet without any defect or dust. The radial run-out of drill must be under 0.02mm.
4. These conditions above are for cutting depth under 5xD.

1. La première fois que vous utilisez sélectionner 90% de la vitesse de coupe recommandée ou 85% de l'alimentation. Avec stable traitement des données de coupe augmentent en conséquence.
2. Les recommandations de données de coupe ci-dessus sont basées sur l'utilisation de l'émulsion.
3. Ne composez jamais un porte-outil défectueux. La concentricité doit être inférieure à 0,02 mm.
4. Les données ci-dessus en coupe sont conçus pour des profondeurs de forage sous 5xD.



VHM Hochleistungsbohrer 5xD

Solid carbide high performance drills 5xD
Forets en carbure a haute performance 5xD

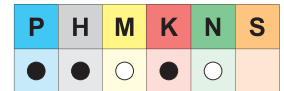
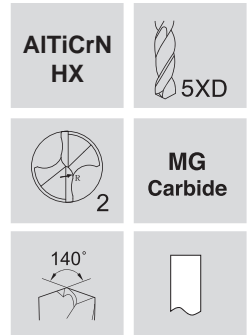
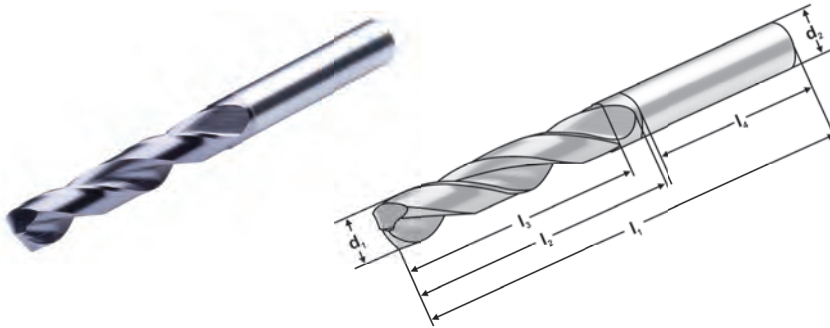

Einsatzgebiete:

Hochleistungsbohren auf CNC-Maschinen und Bearbeitungszentren für höchste Ansprüche an Wirtschaftlichkeit und Bohrungsqualität. Bohren von Stahl, Stahlguss, Grauguss, Temperguss, Chrom- und Nickelwerkstoffen, hochwarmfesten Stählen, Titan- und Titanlegierungen, NE-Metallen, Graphit und Kunststoffen.

Application:

High performance drilling on CNC machines and machining centers for highest bore hole quality and economical output. For drilling of steel, steel casting, gray cast iron, malleable cast iron, Cr-Ni-steels, heat resisting steel, titanium and titanium-alloys, non-ferrous metals, graphite and plastics.

Applications:

Forage à haute performance sur des machines CNC et centres d'usinage pour plus d'efficacité et de qualité du trou. Perçage d'acier, d'acier moulé, de fonte grise, de fonte malléable, de chrome et d'alliages de nickel, d'aciers à haute température, de titane et d'alliages de titane, des métaux non-ferreux, de graphite et des matières plastiques.

Bestell Nr. Order no. Référence	d ₁	d ₂ h6	l ₁	l ₂	l ₃	l ₄
D500.0300	3,00	6	66	28	23	36
D500.0310	3,10	6	66	28	23	36
D500.0320	3,20	6	66	28	23	36
D500.0325	3,25	6	66	28	23	36
D500.0330	3,30	6	66	28	23	36
D500.0340	3,40	6	66	28	23	36
D500.0350	3,50	6	66	28	23	36
D500.0360	3,60	6	66	28	23	36
D500.0370	3,70	6	66	28	23	36
D500.0380	3,80	6	74	36	29	36
D500.0390	3,90	6	74	36	29	36
D500.0400	4,00	6	74	36	29	36
D500.0410	4,10	6	74	36	29	36
D500.0420	4,20	6	74	36	29	36
D500.0430	4,30	6	74	36	29	36
D500.0440	4,40	6	74	36	29	36
D500.0450	4,50	6	74	36	29	36
D500.0460	4,60	6	74	36	29	36
D500.0465	4,65	6	74	36	29	36
D500.0470	4,70	6	74	36	29	36
D500.0480	4,80	6	82	44	35	36
D500.0490	4,90	6	82	44	35	36
D500.0500	5,00	6	82	44	35	36
D500.0510	5,10	6	82	44	35	36
D500.0520	5,20	6	82	44	35	36
D500.0530	5,30	6	82	44	35	36
D500.0540	5,40	6	82	44	35	36
D500.0550	5,50	6	82	44	35	36
D500.0555	5,55	6	82	44	35	36
D500.0560	5,60	6	82	44	35	36
D500.0570	5,70	6	82	44	35	36

Bestell Nr. Order no. Référence	d ₁	d ₂ h6	l ₁	l ₂	l ₃	l ₄
D500.0580	5,80	6	82	44	35	36
D500.0590	5,90	6	82	44	35	36
D500.0600	6,00	6	82	44	35	36
D500.0610	6,10	6	82	44	35	36
D500.0620	6,20	8	91	53	43	36
D500.0630	6,30	8	91	53	43	36
D500.0640	6,40	8	91	53	43	36
D500.0650	6,50	8	91	53	43	36
D500.0660	6,60	8	91	53	43	36
D500.0670	6,70	8	91	53	43	36
D500.0675	6,75	8	91	53	43	36
D500.0680	6,80	8	91	53	43	36
D500.0690	6,90	8	91	53	43	36
D500.0700	7,00	8	91	53	43	36
D500.0710	7,10	8	91	53	43	36
D500.0720	7,20	8	91	53	43	36
D500.0730	7,30	8	91	53	43	36
D500.0740	7,40	8	91	53	43	36
D500.0750	7,50	8	91	53	43	36
D500.0760	7,60	8	91	53	43	36
D500.0770	7,70	8	91	53	43	36
D500.0780	7,80	8	91	53	43	36
D500.0790	7,90	8	91	53	43	36
D500.0800	8,00	8	91	53	43	36
D500.0810	8,10	10	103	61	49	40
D500.0820	8,20	10	103	61	49	40
D500.0830	8,30	10	103	61	49	40
D500.0840	8,40	10	103	61	49	40
D500.0850	8,50	10	103	61	49	40
D500.0860	8,60	10	103	61	49	40
D500.0870	8,70	10	103	61	49	40
D500.0880	8,80	10	103	61	49	40
D500.0890	8,90	10	103	61	49	40
D500.0900	9,00	10	103	61	49	40
D500.0910	9,10	10	103	61	49	40
D500.0920	9,20	10	103	61	49	40
D500.0930	9,30	10	103	61	49	40
D500.0940	9,40	10	103	61	49	40
D500.0950	9,50	10	103	61	49	40
D500.0960	9,60	10	103	61	49	40
D500.0970	9,70	10	103	61	49	40
D500.0980	9,80	10	103	61	49	40
D500.0990	9,90	10	103	61	49	40
D500.1000	10,00	10	103	61	49	45
D500.1010	10,10	12	118	71	56	45
D500.1020	10,20	12	118	71	56	45
D500.1025	10,25	12	118	71	56	45
D500.1030	10,30	12	118	71	56	45
D500.1040	10,40	12	118	71	56	45
D500.1050	10,50	12	118	71	56	45
D500.1060	10,60	12	118	71	56	45

Bestell Nr. Order no. Référence	d ₁	d ₂ h6	l ₁	l ₂	l ₃	l ₄
D500.1070	10,70	12	118	71	56	45
D500.1080	10,80	12	118	71	56	45
D500.1090	10,90	12	118	71	56	45
D500.1100	11,00	12	118	71	56	45
D500.1110	11,10	12	118	71	56	45
D500.1120	11,20	12	118	71	56	45
D500.1130	11,30	12	118	71	56	45
D500.1140	11,40	12	118	71	56	45
D500.1150	11,50	12	118	71	56	45
D500.1160	11,60	12	118	71	56	45
D500.1170	11,70	12	118	71	56	45
D500.1180	11,80	12	118	71	56	45
D500.1190	11,90	12	118	71	56	45
D500.1200	12,00	12	118	71	56	45
D500.1225	12,25	14	124	77	60	45
D500.1230	12,30	14	124	77	60	45
D500.1250	12,50	14	124	77	60	45
D500.1270	12,70	14	124	77	60	45
D500.1275	12,75	14	124	77	60	45
D500.1280	12,80	14	124	77	60	45
D500.1300	13,00	14	124	77	60	45
D500.1310	13,10	14	124	77	60	45
D500.1350	13,50	14	124	77	60	45
D500.1380	13,80	14	124	77	60	45
D500.1400	14,00	14	124	77	60	45
D500.1425	14,25	16	133	83	63	48
D500.1430	14,30	16	133	83	63	48
D500.1450	14,50	16	133	83	63	48
D500.1475	14,75	16	133	83	63	48
D500.1480	14,80	16	133	83	63	48
D500.1500	15,00	16	133	83	63	48
D500.1510	15,10	16	133	83	63	48
D500.1550	15,50	16	133	83	63	48
D500.1580	15,80	16	133	83	63	48
D500.1600	16,00	16	133	83	63	48
D500.1650	16,50	18	143	93	71	48
D500.1675	16,75	18	143	93	71	48
D500.1680	16,80	18	143	93	71	48
D500.1700	17,00	18	143	93	71	48
D500.1750	17,50	18	143	93	71	48
D500.1780	17,80	18	143	93	71	48
D500.1800	18,00	18	143	93	71	48
D500.1850	18,50	20	153	101	77	50
D500.1880	18,80	20	153	101	77	50
D500.1900	19,00	20	153	101	77	50
D500.1950	19,50	20	153	101	77	50
D500.1980	19,80	20	153	101	77	50
D500.2000	20,00	20	153	101	77	50



Cutting data 5xD
Données de coupe 5xD

Materialgruppen Material groups Groupes matières	Vc "0 (mm)"	P Wenig legierter Stahl Low-alloyed steel Acier faible allié		H Stahl 30-38HRC Steel 30-38HRC Acier 30-38HRC		H Stahl 38-48 HRC Steel 38-48 HRC Acier 38-48 HRC		M Edelstahl Stainless Steel Acier inoxydable		K Guss Eisen Cast Iron Fonte		N Aluminium Aluminium Aluminium		N Hitzebeständiger Stahl Heat resistant steel Acier thermostable	
		"n (min-1)"	"f (mm/r)"	"n (min-1)"	"f (mm/r)"	"n (min-1)"	"f (mm/r)"	"n (min-1)"	"f (mm/r)"	"n (min-1)"	"f (mm/r)"	"n (min-1)"	"f (mm/r)"	"n (min-1)"	"f (mm/r)"
2	2	14000	"0,06~ 0,08"	14000	"0,06~ 0,08"	9500	"0,06~ 0,08"	9500	"0,02~ 0,05"	14000	"0,06~ 0,08"	16000	"0,06~ 0,08"	3200	"0,02~ 0,04"
3	3	9500	"0,09~ 0,12"	9500	"0,09~ 0,12"	6300	"0,09~ 0,12"	3700	"0,03~ 0,07"	9500	"0,09~ 0,12"	10600	"0,09~ 0,12"	2100	"0,03~ 0,06"
4	4	7000	"0,10~ 0,15"	7000	"0,10~ 0,15"	4700	"0,10~ 0,15"	2700	"0,04~ 0,08"	7000	"0,10~ 0,15"	8000	"0,10~ 0,15"	1600	"0,04~ 0,07"
5	5	5700	"0,12~ 0,18"	5700	"0,12~ 0,18"	3800	"0,12~ 0,18"	2200	"0,05~ 0,10"	5700	"0,12~ 0,18"	6400	"0,12~ 0,18"	1250	"0,05~ 0,09"
6	6	4700	"0,14~ 0,20"	4700	"0,14~ 0,20"	3100	"0,14~ 0,20"	1850	"0,06~ 0,12"	4700	"0,14~ 0,20"	5300	"0,14~ 0,20"	1050	"0,06~ 0,11"
8	8	3600	"0,16~ 0,24"	3600	"0,16~ 0,24"	2400	"0,16~ 0,24"	1400	"0,08~ 0,16"	3600	"0,16~ 0,24"	4000	"0,16~ 0,24"	800	"0,08~ 0,14"
10	10	2800	"0,18~ 0,27"	2800	"0,18~ 0,27"	1900	"0,18~ 0,27"	1100	"0,10~ 0,18"	2800	"0,18~ 0,27"	3200	"0,18~ 0,27"	600	"0,10~ 0,16"
12	12	2400	"0,20~ 0,30"	2400	"0,20~ 0,30"	1600	"0,20~ 0,30"	930	"0,12~ 0,20"	2400	"0,20~ 0,30"	2700	"0,20~ 0,30"	500	"0,12~ 0,18"
14	14	2100	"0,22~ 0,35"	2100	"0,22~ 0,35"	1400	"0,22~ 0,35"	800	"0,13~ 0,22"	2100	"0,22~ 0,35"	2300	"0,22~ 0,35"	450	"0,13~ 0,20"
16	16	1800	"0,25~ 0,36"	1800	"0,25~ 0,36"	1200	"0,25~ 0,36"	700	"0,14~ 0,25"	1800	"0,25~ 0,36"	2000	"0,25~ 0,36"	400	"0,14~ 0,23"
18	18	1600	"0,28~ 0,38"	1600	"0,28~ 0,38"	1100	"0,28~ 0,38"	620	"0,15~ 0,28"	1600	"0,28~ 0,38"	1800	"0,28~ 0,38"	350	"0,15~ 0,25"
20	20	1400	"0,30~ 0,40"	1400	"0,30~ 0,40"	950	"0,30~ 0,40"	550	"0,16~ 0,30"	1400	"0,30~ 0,40"	1600	"0,30~ 0,40"	320	"0,16~ 0,28"

1. Beim ersten Einsatz 90% der empfohlenen Schnittgeschwindigkeit oder 85% des Vorschubes wählen. Bei stabiler Bearbeitung die Schnittdaten entsprechend erhöhen.
2. Die obigen Schnittdatenempfehlungen basieren auf dem Einsatz von Emulsion.
3. Keine defekte Werkzeugaufnahme wählen. Die Rundlaufgenauigkeit muss unter 0,02mm liegen.
4. Die obigen Schnittdaten sind für Bohrungstiefen unter 5xD ausgelegt.

1. When the tool is used for the first time, please make a test cutting with 90% of cutting speed or 85% feed rate mentioned above. If the cutting conditions remain stable, gradually increase the cutting speed and feed rate.
2. The cutting conditions above are for drilling with emulsion.
3. Use a collet without any defect or dust. The radial run-out of drill must be under 0.02mm.
4. These conditions above are for cutting depth under 5xD.

1. La première fois que vous utilisez sélectionnez 90% de la vitesse de coupe recommandée ou 85% de l'alimentation. Avec stable traitement des données de coupe augmentent en conséquence.
2. Les recommandations de données de coupe ci-dessus sont basées sur l'utilisation de l'émulsion.
3. Ne composez jamais un porte-outil défectueux. La concentricité doit être inférieure à 0,02 mm.
4. Les données ci-dessus en coupe sont conçus pour des profondeurs de forage sous 5xD.



VHM Hochleistungsbohrer 5xD mit Innenkühlung

Solid carbide high performance drills 5xD with internal coolant
Forets en carbure a haute performance 5xD avec arrosage centrale

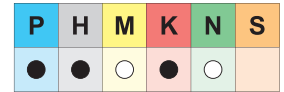
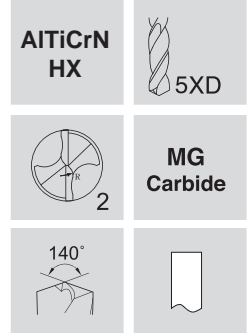
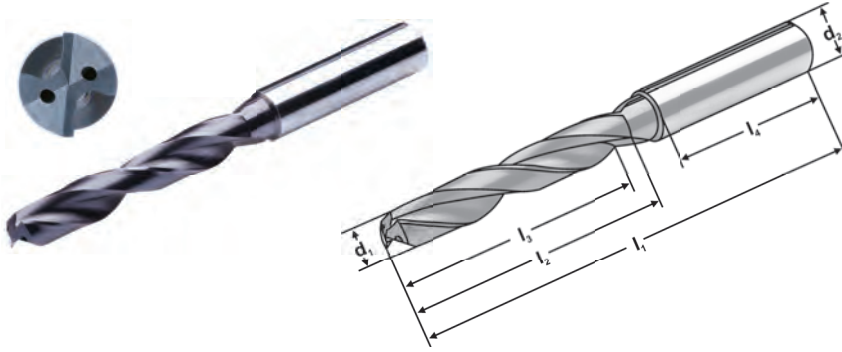

Einsatzgebiete:

Hochleistungsbohren auf CNC-Maschinen und Bearbeitungszentren für höchste Ansprüche an Wirtschaftlichkeit und Bohrungsqualität. Bohren von Stahl, Stahlguss, Grauguss, Temperguss, Chrom- und Nickelwerkstoffen, hochwarmfesten Stählen, Titan- und Titanlegierungen, NE-Metallen, Graphit und Kunststoffen.

Application:

High performance drilling on CNC machines and machining centers for highest bore hole quality and economical output. For drilling of steel, steel casting, gray cast iron, malleable cast iron, Cr-Ni-steels, heat resisting steel, titanium and titanium-alloys, non-ferrous metals, graphite and plastics.

Applications:

Forage à haute performance sur des machines CNC et centres d'usinage pour plus d'efficacité et de qualité du trou. Perçage d'acier, d'acier moulé, de fonte grise, de fonte malléable, de chrome et d'alliages de nickel, d'aciers à haute température, de titane et d'alliages de titane, des métaux non-ferreux, de graphite et des matières plastiques.

Bestell Nr. Order no. Référence	d ₁	d ₂ h6	l ₁	l ₂	l ₃	l ₄
D501.0300	3,00	6	66	28	23	36
D501.0310	3,10	6	66	28	23	36
D501.0320	3,20	6	66	28	23	36
D501.0325	3,25	6	66	28	23	36
D501.0330	3,30	6	66	28	23	36
D501.0340	3,40	6	66	28	23	36
D501.0350	3,50	6	66	28	23	36
D501.0360	3,60	6	66	28	23	36
D501.0370	3,70	6	66	28	23	36
D501.0380	3,80	6	74	36	29	36
D501.0390	3,90	6	74	36	29	36
D501.0400	4,00	6	74	36	29	36
D501.0410	4,10	6	74	36	29	36
D501.0420	4,20	6	74	36	29	36
D501.0430	4,30	6	74	36	29	36
D501.0440	4,40	6	74	36	29	36
D501.0450	4,50	6	74	36	29	36
D501.0460	4,60	6	74	36	29	36
D501.0465	4,65	6	74	36	29	36
D501.0470	4,70	6	74	36	29	36
D501.0480	4,80	6	82	44	35	36
D501.0490	4,90	6	82	44	35	36
D501.0500	5,00	6	82	44	35	36
D501.0510	5,10	6	82	44	35	36
D501.0520	5,20	6	82	44	35	36
D501.0530	5,30	6	82	44	35	36
D501.0540	5,40	6	82	44	35	36
D501.0550	5,50	6	82	44	35	36
D501.0555	5,55	6	82	44	35	36
D501.0560	5,60	6	82	44	35	36
D501.0570	5,70	6	82	44	35	36

Bestell Nr. Order no. Référence	d ₁	d ₂ h6	l ₁	l ₂	l ₃	l ₄
D501.0580	5,80	6	82	44	35	36
D501.0590	5,90	6	82	44	35	36
D501.0600	6,00	6	82	44	35	36
D501.0610	6,10	8	91	53	43	36
D501.0620	6,20	8	91	53	43	36
D501.0630	6,30	8	91	53	43	36
D501.0640	6,40	8	91	53	43	36
D501.0650	6,50	8	91	53	43	36
D501.0660	6,60	8	91	53	43	36
D501.0670	6,70	8	91	53	43	36
D501.0675	6,75	8	91	53	43	36
D501.0680	6,80	8	91	53	43	36
D501.0690	6,90	8	91	53	43	36
D501.0700	7,00	8	91	53	43	36
D501.0710	7,10	8	91	53	43	36
D501.0720	7,20	8	91	53	43	36
D501.0730	7,30	8	91	53	43	36
D501.0740	7,40	8	91	53	43	36
D501.0750	7,50	8	91	53	43	36
D501.0760	7,60	8	91	53	43	36
D501.0770	7,70	8	91	53	43	36
D501.0780	7,80	8	91	53	43	36
D501.0790	7,90	8	91	53	43	36
D501.0800	8,00	8	91	53	43	36
D501.0810	8,10	10	103	61	49	40
D501.0820	8,20	10	103	61	49	40
D501.0830	8,30	10	103	61	49	40
D501.0840	8,40	10	103	61	49	40
D501.0850	8,50	10	103	61	49	40
D501.0860	8,60	10	103	61	49	40
D501.0870	8,70	10	103	61	49	40
D501.0880	8,80	10	103	61	49	40
D501.0890	8,90	10	103	61	49	40
D501.0900	9,00	10	103	61	49	40
D501.0910	9,10	10	103	61	49	40
D501.0920	9,20	10	103	61	49	40
D501.0930	9,30	10	103	61	49	40
D501.0940	9,40	10	103	61	49	40
D501.0950	9,50	10	103	61	49	40
D501.0960	9,60	10	103	61	49	40
D501.0970	9,70	10	103	61	49	40
D501.0980	9,80	10	103	61	49	40
D501.0990	9,90	10	103	61	49	40
D501.1000	10,00	10	103	61	49	40
D501.1010	10,10	12	118	71	56	45
D501.1020	10,20	12	118	71	56	45
D501.1025	10,25	12	118	71	56	45
D501.1030	10,30	12	118	71	56	45
D501.1040	10,40	12	118	71	56	45
D501.1050	10,50	12	118	71	56	45
D501.1060	10,60	12	118	71	56	45

Bestell Nr. Order no. Référence	d ₁	d ₂ h6	l ₁	l ₂	l ₃	l ₄
D501.1070	10,70	12	118	71	56	45
D501.1080	10,80	12	118	71	56	45
D501.1090	10,90	12	118	71	56	45
D501.1100	11,00	12	118	71	56	45
D501.1110	11,10	12	118	71	56	45
D501.1120	11,20	12	118	71	56	45
D501.1130	11,30	12	118	71	56	45
D501.1140	11,40	12	118	71	56	45
D501.1150	11,50	12	118	71	56	45
D501.1160	11,60	12	118	71	56	45
D501.1170	11,70	12	118	71	56	45
D501.1180	11,80	12	118	71	56	45
D501.1190	11,90	12	118	71	56	45
D501.1200	12,00	12	118	71	56	45
D501.1210	12,10	14	124	77	60	45
D501.1225	12,25	14	124	77	60	45
D501.1230	12,30	14	124	77	60	45
D501.1250	12,50	14	124	77	60	45
D501.1270	12,70	14	124	77	60	45
D501.1275	12,75	14	124	77	60	45
D501.1280	12,80	14	124	77	60	45
D501.1300	13,00	14	124	77	60	45
D501.1310	13,10	14	124	77	60	45
D501.1350	13,50	14	124	77	60	45
D501.1380	13,80	14	124	77	60	45
D501.1400	14,00	14	124	77	60	45
D501.1425	14,25	16	133	83	63	48
D501.1430	14,30	16	133	83	63	48
D501.1450	14,50	16	133	83	63	48
D501.1475	14,75	16	133	83	63	48
D501.1480	14,80	16	133	83	63	48
D501.1500	15,00	16	133	83	63	48
D501.1510	15,10	16	133	83	63	48
D501.1550	15,50	16	133	83	63	48
D501.1580	15,80	16	133	83	63	48
D501.1600	16,00	16	133	83	63	48
D501.1650	16,50	18	143	93	71	48
D501.1675	16,75	18	143	93	71	48
D501.1680	16,80	18	143	93	71	48
D501.1700	17,00	18	143	93	71	48
D501.1750	17,50	18	143	93	71	48
D501.1780	17,80	18	143	93	71	48
D501.1800	18,00	18	143	93	71	48
D501.1850	18,50	20	153	101	77	50
D501.1880	18,80	20	153	101	77	50
D501.1900	19,00	20	153	101	77	50
D501.1950	19,50	20	153	101	77	50
D501.1980	19,80	20	153	101	77	50
D501.2000	20,00	20	153	101	77	50

Cutting data 5xD

Données de coupe 5xD

Materialgruppen Materiá groups Groupes matiéres	Vc "n (mm)"	P Wenig legierter Stahl Low-alloyed steel Acier faible allié		H Stahl 30-38HRC Steel 30-38HRC Acier 30-38HRC		H Stahl 38-48 HRC Steel 38-48 HRC Acier 38-48 HRC		M Edelstahl Stainless Steel Acier inoxydable		K GGusseisen Cast Iron Fonte		N Aluminium Aluminium Aluminium		Hitzeresistenter Stahl Heat resistant steel Acier thermostable	
		"n (min-1)"	"f (mm/r)"	"n (min-1)"	"f (mm/r)"	"n (min-1)"	"f (mm/r)"	"n (min-1)"	"f (mm/r)"	"n (min-1)"	"f (mm/r)"	"n (min-1)"	"f (mm/r)"	"n (min-1)"	"f (mm/r)"
3	3	12700	"0,09~ 0,12"	12700	"0,09~ 0,12"	7400	"0,09~ 0,12"	6300	"0,03~ 0,07"	12700	"0,09~ 0,12"	9500	"0,09~ 0,12"	2100	"0,03~ 0,06"
4	4	9600	"0,10~ 0,15"	9600	"0,10~ 0,15"	5600	"0,10~ 0,15"	4700	"0,04~ 0,08"	9600	"0,10~ 0,15"	7000	"0,10~ 0,15"	1600	"0,04~ 0,07"
5	5	7600	"0,12~ 0,18"	7600	"0,12~ 0,18"	4500	"0,12~ 0,18"	3800	"0,05~ 0,10"	7600	"0,12~ 0,18"	5700	"0,12~ 0,18"	1250	"0,05~ 0,09"
6	6	6400	"0,14~ 0,20"	6400	"0,14~ 0,20"	3700	"0,14~ 0,20"	3700	"0,06~ 0,12"	6400	"0,14~ 0,20"	4700	"0,14~ 0,20"	1050	"0,06~ 0,11"
8	8	4800	"0,16~ 0,24"	4800	"0,16~ 0,24"	2800	"0,16~ 0,24"	2400	"0,08~ 0,16"	4800	"0,16~ 0,24"	3600	"0,16~ 0,24"	800	"0,08~ 0,14"
10	10	3800	"0,18~ 0,27"	3800	"0,18~ 0,27"	2200	"0,18~ 0,27"	1900	"0,10~ 0,18"	3800	"0,18~ 0,27"	2800	"0,18~ 0,27"	600	"0,10~ 0,16"
12	12	3200	"0,20~ 0,30"	3200	"0,20~ 0,30"	1900	"0,20~ 0,30"	1600	"0,12~ 0,20"	3200	"0,20~ 0,30"	2400	"0,20~ 0,30"	500	"0,12~ 0,18"
14	14	2700	"0,22~ 0,35"	2700	"0,22~ 0,35"	1600	"0,22~ 0,35"	1350	"0,13~ 0,22"	2700	"0,22~ 0,35"	2100	"0,22~ 0,35"	450	"0,13~ 0,20"
16	16	2400	"0,25~ 0,38"	2400	"0,25~ 0,38"	1400	"0,25~ 0,38"	1200	"0,14~ 0,25"	2400	"0,25~ 0,38"	1800	"0,25~ 0,38"	400	"0,14~ 0,23"
18	18	2100	"0,28~ 0,38"	2100	"0,28~ 0,38"	1200	"0,28~ 0,38"	1050	"0,15~ 0,28"	2100	"0,28~ 0,38"	1600	"0,28~ 0,38"	350	"0,15~ 0,25"
20	20	1900	"0,30~ 0,40"	1900	"0,30~ 0,40"	1100	"0,30~ 0,40"	950	"0,16~ 0,30"	1900	"0,30~ 0,40"	1400	"0,30~ 0,40"	320	"0,16~ 0,28"

1. Beim ersten Einsatz 90% der empfohlenen Schnittgeschwindigkeit oder 85% des Vorschubes wählen. Bei stabiler Bearbeitung die Schnittdaten entsprechend erhöhen.
2. Die obigen Schnittdatenempfehlungen basieren auf dem Einsatz von Emulsion.
3. Keine defekte Werkzeugaufnahme wählen. Die Rundlaufgenauigkeit muss unter 0,02mm liegen.
4. Die obigen Schnittdaten sind für Bohrungstiefen unter 5xD ausgelegt.

1. When the tool is used for the first time, please make a test cutting with 90% of cutting speed or 85% feed rate mentioned above. If the cutting conditions remain stable, gradually increase the cutting speed and feed rate.
2. The cutting conditions above are for drilling with emulsion.
3. Use a collet without any defect or dust. The radial run-out of drill must be under 0.02mm.
4. These conditions above are for cutting depth under 5xD.

1. La première fois que vous utilisez sélectionner 90% de la vitesse de coupe recommandée ou 85% de l'alimentation. Avec stable traitement des données de coupe augmentent en conséquence.
2. Les recommandations de données de coupe ci-dessus sont basées sur l'utilisation de l'émulsion.
3. Ne composez jamais un porte-outil défectueux. La concentricité doit être inférieure à 0,02 mm.
4. Les données ci-dessus en coupe sont conçus pour des profondeurs de forage sous 5xD.



VHM Hochleistungsbohrer 5xD mit Innenkühlung und Weldon Fläche

Solid carbide high performance drills 5xD with internal coolant and weldon shank
Forets en carbure a haute performance 5xD avec arrosage centrale et face weldon

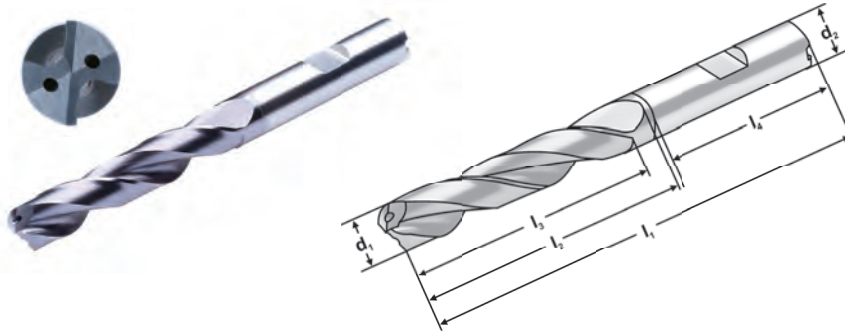

AlTiCrN HX	5XD
2	MG Carbide
140°	DIN 6535 HB

P	H	M	K	N	S
●	●	○	●	○	○

Einsatzgebiete:

Hochleistungsbohren auf CNC-Maschinen und Bearbeitungszentren für höchste Ansprüche an Wirtschaftlichkeit und Bohrungsqualität. Bohren von Stahl, Stahlguss, Grauguss, Temporguss, Chrom- und Nickelwerkstoffen, hochwarmfesten Stählen, Titan- und Titanlegierungen, NE-Metallen, Graphit und Kunststoffen.

Application:

High performance drilling on CNC machines and machining centers for highest bore hole quality and economical output. For drilling of steel, steel casting, gray cast iron, malleable cast iron, Cr-Ni-steels, heat resisting steel, titanium and titanium-alloys, non-ferrous metals, graphite and plastics.

Applications:

Forage à haute performance sur des machines CNC et centres d'usinage pour plus d'efficacité et de qualité du trou.
Perçage d'acier, d'acier moulé, de fonte grise, de fonte malléable, de chrome et d'alliages de nickel, d'aciers à haute température, de titane et d'alliages de titane, des métaux non-ferreux, de graphite et des matières plastiques.

Bestell Nr. Order no. Référence	d ₁	d ₂ h6	l ₁	l ₂	l ₃	l ₄
D502.0300	3,00	6	66	28	23	36
D502.0310	3,10	6	66	28	23	36
D502.0320	3,20	6	66	28	23	36
D502.0325	3,25	6	66	28	23	36
D502.0330	3,30	6	66	28	23	36
D502.0340	3,40	6	66	28	23	36
D502.0350	3,50	6	66	28	23	36
D502.0360	3,60	6	66	28	23	36
D502.0370	3,70	6	66	28	23	36
D502.0380	3,80	6	74	36	29	36
D502.0390	3,90	6	74	36	29	36
D502.0400	4,00	6	74	36	29	36
D502.0410	4,10	6	74	36	29	36
D502.0420	4,20	6	74	36	29	36
D502.0430	4,30	6	74	36	29	36
D502.0440	4,40	6	74	36	29	36
D502.0450	4,50	6	74	36	29	36
D502.0460	4,60	6	74	36	29	36
D502.0465	4,65	6	74	36	29	36
D502.0470	4,70	6	74	36	29	36
D502.0480	4,80	6	82	44	35	36
D502.0490	4,90	6	82	44	35	36
D502.0500	5,00	6	82	44	35	36
D502.0510	5,10	6	82	44	35	36
D502.0520	5,20	6	82	44	35	36
D502.0530	5,30	6	82	44	35	36
D502.0540	5,40	6	82	44	35	36
D502.0550	5,50	6	82	44	35	36
D502.0555	5,55	6	82	44	35	36
D502.0560	5,60	6	82	44	35	36
D502.0570	5,70	6	82	44	35	36

Bestell Nr. Order no. Référence	d ₁	d ₂ h ₆	l ₁	l ₂	l ₃	l ₄
D502.0580	5,80	6	82	44	35	36
D502.0590	5,90	6	82	44	35	36
D502.0600	6,00	6	82	44	35	36
D502.0610	6,10	8	91	53	43	36
D502.0620	6,20	8	91	53	43	36
D502.0630	6,30	8	91	53	43	36
D502.0640	6,40	8	91	53	43	36
D502.0650	6,50	8	91	53	43	36
D502.0660	6,60	8	91	53	43	36
D502.0670	6,70	8	91	53	43	36
D502.0675	6,75	8	91	53	43	36
D502.0680	6,80	8	91	53	43	36
D502.0690	6,90	8	91	53	43	36
D502.0700	7,00	8	91	53	43	36
D502.0710	7,10	8	91	53	43	36
D502.0720	7,20	8	91	53	43	36
D502.0730	7,30	8	91	53	43	36
D502.0740	7,40	8	91	53	43	36
D502.0750	7,50	8	91	53	43	36
D502.0760	7,60	8	91	53	43	36
D502.0770	7,70	8	91	53	43	36
D502.0780	7,80	8	91	53	43	36
D502.0790	7,90	8	91	53	43	36
D502.0800	8,00	8	91	53	43	36
D502.0810	8,10	10	103	61	49	40
D502.0820	8,20	10	103	61	49	40
D502.0830	8,30	10	103	61	49	40
D502.0840	8,40	10	103	61	49	40
D502.0850	8,50	10	103	61	49	40
D502.0860	8,60	10	103	61	49	40
D502.0870	8,70	10	103	61	49	40
D502.0880	8,80	10	103	61	49	40
D502.0890	8,90	10	103	61	49	40
D502.0900	9,00	10	103	61	49	40
D502.0910	9,10	10	103	61	49	40
D502.0920	9,20	10	103	61	49	40
D502.0930	9,30	10	103	61	49	40
D502.0940	9,40	10	103	61	49	40
D502.0950	9,50	10	103	61	49	40
D502.0960	9,60	10	103	61	49	40
D502.0970	9,70	10	103	61	49	40
D502.0980	9,80	10	103	61	49	40
D502.0990	9,90	10	103	61	49	40
D502.1000	10,00	10	103	61	49	40
D502.1010	10,10	12	118	71	56	45
D502.1020	10,20	12	118	71	56	45
D502.1025	10,25	12	118	71	56	45
D502.1030	10,30	12	118	71	56	45
D502.1040	10,40	12	118	71	56	45
D502.1050	10,50	12	118	71	56	45
D502.1060	10,60	12	118	71	56	45

Bestell Nr. Order no. Référence	d ₁	d ₂ h6	l ₁	l ₂	l ₃	l ₄
D502.1070	10,70	12	118	71	56	45
D502.1080	10,80	12	118	71	56	45
D502.1090	10,90	12	118	71	56	45
D502.1100	11,00	12	118	71	56	45
D502.1110	11,10	12	118	71	56	45
D502.1120	11,20	12	118	71	56	45
D502.1130	11,30	12	118	71	56	45
D502.1140	11,40	12	118	71	56	45
D502.1150	11,50	12	118	71	56	45
D502.1160	11,60	12	118	71	56	45
D502.1170	11,70	12	118	71	56	45
D502.1180	11,80	12	118	71	56	45
D502.1190	11,90	12	118	71	56	45
D502.1200	12,00	12	118	71	56	45
D502.1210	12,10	14	124	77	60	45
D502.1225	12,25	14	124	77	60	45
D502.1230	12,30	14	124	77	60	45
D502.1250	12,50	14	124	77	60	45
D502.1270	12,70	14	124	77	60	45
D502.1275	12,75	14	124	77	60	45
D502.1280	12,80	14	124	77	60	45
D502.1300	13,00	14	124	77	60	45
D502.1310	13,10	14	124	77	60	45
D502.1350	13,50	14	124	77	60	45
D502.1380	13,80	14	124	77	60	45
D502.1400	14,00	14	124	77	60	45
D502.1425	14,25	16	133	83	63	48
D502.1430	14,30	16	133	83	63	48
D502.1450	14,50	16	133	83	63	48
D502.1475	14,75	16	133	83	63	48
D502.1480	14,80	16	133	83	63	48
D502.1500	15,00	16	133	83	63	48
D502.1510	15,10	16	133	83	63	48
D502.1550	15,50	16	133	83	63	48
D502.1580	15,80	16	133	83	63	48
D502.1600	16,00	16	133	83	63	48
D502.1650	16,50	18	143	93	71	48
D502.1675	16,75	18	143	93	71	48
D502.1680	16,80	18	143	93	71	48
D502.1700	17,00	18	143	93	71	48
D502.1750	17,50	18	143	93	71	48
D502.1780	17,80	18	143	93	71	48
D502.1800	18,00	18	143	93	71	48
D502.1850	18,50	20	153	101	77	50
D502.1880	18,80	20	153	101	77	50
D502.1900	19,00	20	153	101	77	50
D502.1950	19,50	20	153	101	77	50
D502.1980	19,80	20	153	101	77	50
D502.2000	20,00	20	153	101	77	50



Cutting data 5xD
Données de coupe 5xD

Vc (mm/min)	P Wenig legierter Stahl Low-alloyed steel Acier faible allié		H Stahl 30-38HRC Steel 30-38HRC Acier 30-38HRC		H Stahl 38-48 HRC Steel 38-48 HRC Acier 38-48 HRC		M Edelstahl Stainless Steel Acier inoxydable		K Guss Eisen Cast Iron Fonte		N Graphit Graphite		N Aluminium Aluminium		N Hitzebeständiger Stahl Heat resistant steel Acier thermostabilisant	
	"n (min-1)"	"f (mm/r)"	"n (min-1)"	"f (mm/r)"	"n (min-1)"	"f (mm/r)"	"n (min-1)"	"f (mm/r)"	"n (min-1)"	"f (mm/r)"	"n (min-1)"	"f (mm/r)"	"n (min-1)"	"f (mm/r)"	"n (min-1)"	"f (mm/r)"
3	12700	"0.09-0.12"	12700	"0.09-0.12"	7400	"0.09-0.12"	6300	"0.03-0.07"	12700	"0.09-0.12"	9500	"0.09-0.12"	15000	"0.09-0.12"	2100	"0.03-0.06"
4	9600	"0.10-0.15"	9600	"0.10-0.15"	5600	"0.10-0.15"	4700	"0.04-0.08"	9600	"0.10-0.15"	7000	"0.10-0.15"	11100	"0.10-0.15"	1600	"0.04-0.07"
5	7600	"0.12-0.18"	7600	"0.12-0.18"	4500	"0.12-0.18"	3800	"0.05-0.10"	7600	"0.12-0.18"	5700	"0.12-0.18"	9000	"0.12-0.18"	1250	"0.05-0.09"
6	6400	"0.14-0.20"	6400	"0.14-0.20"	3700	"0.14-0.20"	3200	"0.06-0.12"	6400	"0.14-0.20"	4700	"0.14-0.20"	7400	"0.14-0.20"	1050	"0.06-0.11"
8	4800	"0.16-0.24"	4800	"0.16-0.24"	2800	"0.16-0.24"	2400	"0.08-0.16"	4800	"0.16-0.24"	3600	"0.16-0.24"	5600	"0.16-0.24"	800	"0.08-0.14"
10	3800	"0.18-0.27"	3800	"0.18-0.27"	2200	"0.18-0.27"	1900	"0.10-0.18"	3800	"0.18-0.27"	2800	"0.18-0.27"	4500	"0.18-0.27"	600	"0.10-0.16"
12	3200	"0.20-0.30"	3200	"0.20-0.30"	1900	"0.20-0.30"	1600	"0.12-0.20"	3200	"0.20-0.30"	2400	"0.20-0.30"	3700	"0.20-0.30"	500	"0.12-0.18"
14	2700	"0.22-0.35"	2700	"0.22-0.35"	1600	"0.22-0.35"	1350	"0.13-0.22"	2700	"0.22-0.35"	2100	"0.22-0.35"	3200	"0.22-0.35"	450	"0.13-0.20"
16	2400	"0.25-0.36"	2400	"0.25-0.36"	1400	"0.25-0.36"	1200	"0.14-0.25"	2400	"0.25-0.36"	1800	"0.25-0.36"	2800	"0.25-0.36"	400	"0.14-0.23"
18	2100	"0.28-0.38"	2100	"0.28-0.38"	1200	"0.28-0.38"	1050	"0.15-0.28"	2100	"0.28-0.38"	1600	"0.28-0.38"	2500	"0.28-0.38"	350	"0.15-0.25"
20	1900	"0.30-0.40"	1900	"0.30-0.40"	1100	"0.30-0.40"	950	"0.16-0.30"	1900	"0.30-0.40"	1400	"0.30-0.40"	2300	"0.30-0.40"	320	"0.16-0.28"

1. Beim ersten Einsatz 90% der empfohlenen Schnittgeschwindigkeit oder 85% des Vorschubes wählen. Bei stabiler Bearbeitung die Schnittdaten entsprechend erhöhen.
2. Die obigen Schnittdatenempfehlungen basieren auf dem Einsatz von Emulsion.
3. Keine defekte Werkzeugaufnahme wählen. Die Rundlaufgenauigkeit muss unter 0,02mm liegen.
4. Die obigen Schnittdaten sind für Bohrungstiefen unter 5xD ausgelegt.

1. When the tool is used for the first time, please make a test cutting with 90% of cutting speed or 85% feed rate mentioned above. If the cutting conditions remain stable, gradually increase the cutting speed and feed rate.
2. The cutting conditions above are for drilling with emulsion.
3. Use a collet without any defect or dust. The radial run-out of drill must be under 0.02mm.
4. These conditions above are for cutting depth under 5xD.

1. La première fois que vous utilisez sélectionner 90% de la vitesse de coupe recommandée ou 85% de l'alimentation. Avec stable traitement des données de coupe augmentent en conséquence.
2. Les recommandations de données de coupe ci-dessus sont basées sur l'utilisation de l'émulsion.
3. Ne composez jamais un porte-outil défectueux. La concentricité doit être inférieure à 0,02 mm.
4. Les données ci-dessus en coupe sont conçus pour des profondeurs de forage sous 5xD.



VHM Hochleistungsbohrer 8xD mit Innenkühlung

Solid carbide high performance drills 8xD with internal coolant
Forets en carbure a haute performance 8xD avec arrosage centrale

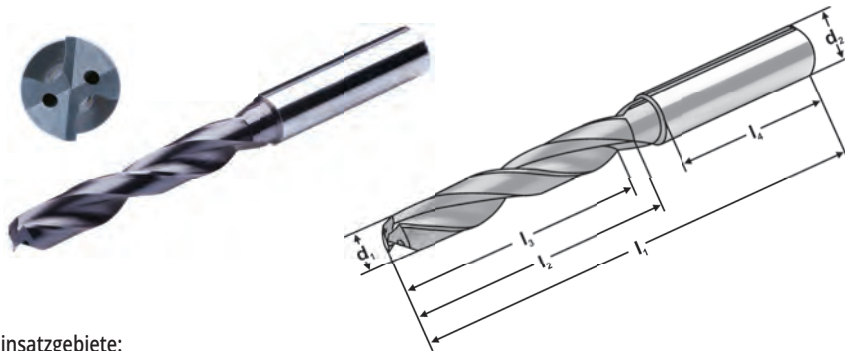

AlTiCrN HX	8XD
2	MG Carbide
140°	DIN 6535 HB

P	H	M	K	N	S
●	●	○	●	○	○

Einsatzgebiete:

Hochleistungsbohren auf CNC-Maschinen und Bearbeitungszentren für höchste Ansprüche an Wirtschaftlichkeit und Bohrungsqualität. Bohren von Stahl, Stahlguss, Grauguss, Temperguss, Chrom- und Nickelwerkstoffen, hochwarmfesten Stählen, Titan- und Titanlegierungen, NE-Metallen, Graphit und Kunststoffen.

Application:

High performance drilling on CNC machines and machining centers for highest bore hole quality and economical output. For drilling of steel, steel casting, gray cast iron, malleable cast iron, Cr-Ni-steels, heat resisting steel, titanium and titanium-alloys, non-ferrous metals, graphite and plastics.

Applications:

Forage à haute performance sur des machines CNC et centres d'usinage pour plus d'efficacité et de qualité du trou. Perçage d'acier, d'acier moulé, de fonte grise, de fonte malléable, de chrome et d'alliages de nickel, d'aciers à haute température, de titane et d'alliages de titane, des métaux non-ferreux, de graphite et des matières plastiques.

Bestell Nr. Order no. Référence	d ₁	d ₂ h6	l ₁	l ₂	l ₃	l ₄
D801.0300	3,00	6	72	34	29	36
D801.0310	3,10	6	72	34	29	36
D801.0320	3,20	6	72	34	29	36
D801.0330	3,30	6	72	34	29	36
D801.0340	3,40	6	72	34	29	36
D801.0350	3,50	6	72	34	29	36
D801.0360	3,60	6	72	34	29	36
D801.0370	3,70	6	72	34	29	36
D801.0380	3,80	6	81	43	36	36
D801.0390	3,90	6	81	43	36	36
D801.0400	4,00	6	81	43	36	36
D801.0410	4,10	6	81	43	36	36
D801.0420	4,20	6	81	43	36	36
D801.0430	4,30	6	81	43	36	36
D801.0440	4,40	6	81	43	36	36
D801.0450	4,50	6	81	43	36	36
D801.0460	4,60	6	81	43	36	36
D801.0470	4,70	6	81	43	36	36
D801.0480	4,80	6	95	57	48	36
D801.0490	4,90	6	95	57	48	36
D801.0500	5,00	6	95	57	48	36
D801.0510	5,10	6	95	57	48	36
D801.0520	5,20	6	95	57	48	36
D801.0530	5,30	6	95	57	48	36
D801.0540	5,40	6	95	57	48	36
D801.0550	5,50	6	95	57	48	36
D801.0560	5,60	6	95	57	48	36
D801.0570	5,70	6	95	57	48	36
D801.0580	5,80	6	95	57	48	36
D801.0590	5,90	6	95	57	48	36
D801.0600	6,00	6	95	57	48	36

Bestell Nr. Order no. Référence	d ₁	d ₂ h6	l ₁	l ₂	l ₃	l ₄
D801.0610	6,10	8	114	76	66	36
D801.0620	6,20	8	114	76	66	36
D801.0630	6,30	8	114	76	66	36
D801.0640	6,40	8	114	76	66	36
D801.0650	6,50	8	114	76	66	36
D801.0660	6,60	8	114	76	66	36
D801.0670	6,70	8	114	76	66	36
D801.0680	6,80	8	114	76	66	36
D801.0690	6,90	8	114	76	66	36
D801.0700	7,00	8	116	76	66	36
D801.0710	7,10	8	116	76	66	36
D801.0720	7,20	8	116	76	66	36
D801.0730	7,30	8	116	76	66	36
D801.0740	7,40	8	116	76	66	36
D801.0750	7,50	8	116	76	66	36
D801.0760	7,60	8	116	76	66	36
D801.0770	7,70	8	116	76	66	36
D801.0780	7,80	8	116	76	66	36
D801.0790	7,90	8	116	76	66	36
D801.0800	8,00	8	116	76	66	36
D801.0810	8,10	10	142	95	83	40
D801.0820	8,20	10	142	95	83	40
D801.0830	8,30	10	142	95	83	40
D801.0840	8,40	10	142	95	83	40
D801.0850	8,50	10	142	95	83	40
D801.0860	8,60	10	142	95	83	40
D801.0870	8,70	10	142	95	83	40
D801.0880	8,80	10	142	95	83	40
D801.0890	8,90	10	142	95	83	40
D801.0900	9,00	10	142	95	83	40
D801.0910	9,10	10	142	95	83	40
D801.0920	9,20	10	142	95	83	40
D801.0930	9,30	10	142	95	83	40
D801.0940	9,40	10	142	95	83	40
D801.0950	9,50	10	142	95	83	40
D801.0960	9,60	10	142	95	83	40
D801.0970	9,70	10	142	95	83	40
D801.0980	9,80	10	142	95	83	40
D801.0990	9,90	10	142	95	83	40
D801.1000	10,00	10	142	95	83	40
D801.1010	10,10	12	162	114	99	45
D801.1020	10,20	12	162	114	99	45
D801.1030	10,30	12	162	114	99	45
D801.1040	10,40	12	162	114	99	45
D801.1050	10,50	12	162	114	99	45
D801.1060	10,60	12	162	114	99	45
D801.1070	10,70	12	162	114	99	45
D801.1080	10,80	12	162	114	99	45
D801.1090	10,90	12	162	114	99	45
D801.1100	11,00	12	162	114	99	45
D801.1110	11,10	12	162	114	99	45



Bestell Nr. Order no. Référence	d ₁	d ₂ h6	l ₁	l ₂	l ₃	l ₄
D801.1120	11,20	12	162	114	99	45
D801.1130	11,30	12	162	114	99	45
D801.1140	11,40	12	162	114	99	45
D801.1150	11,50	12	162	114	99	45
D801.1160	11,60	12	162	114	99	45
D801.1170	11,70	12	162	114	99	45
D801.1180	11,80	12	162	114	99	45
D801.1190	11,90	12	162	114	99	45
D801.1200	12,00	12	162	114	99	45
D801.1250	12,50	14	178	133	116	45
D801.1270	12,70	14	178	133	116	45
D801.1280	12,80	14	178	133	116	45
D801.1300	13,00	14	178	133	116	45
D801.1350	13,50	14	178	133	116	45
D801.1400	14,00	14	178	133	116	45
D801.1450	14,50	16	204	152	132	48
D801.1480	14,80	16	204	152	132	48
D801.1500	15,00	16	204	152	132	48
D801.1550	15,50	16	204	152	132	48
D801.1600	16,00	16	204	152	132	48
D801.1650	16,50	18	223	171	149	48
D801.1700	17,00	18	223	171	149	48
D801.1750	17,50	18	223	171	149	48
D801.1800	18,00	18	223	171	149	48

Cutting data 8xD

Données de coupe 8xD

Materialgruppen Material groups Groupes matières	Vc (mm)	P Wenig legierter Stahl Low-alloyed steel Acier faible allié		H Stahl 30-38HRC Steel 30-38HRC Acier 30-38HRC		H Stahl 38-48 HRC Steel 38-48 HRC Acier 38-48 HRC		M Edelstahl Stainless Steel Acier inoxydable		K GGusseisen Cast Iron Fonte		N Aluminium Aluminium Aluminium		N Hitzebeständiger Stahl Heat resistant steel Acier thermorésistant	
		"n (min-1)"	"vf (mm/r)"	"n (min-1)"	"vf (mm/r)"	"n (min-1)"	"vf (mm/r)"	"n (min-1)"	"vf (mm/r)"	"n (min-1)"	"vf (mm/r)"	"n (min-1)"	"vf (mm/r)"	"n (min-1)"	"vf (mm/r)"
3	3	12700	"0,06~ 0,10"	12700	"0,06~ 0,10"	7400	"0,06~ 0,10"	5300	"0,03~ 0,07"	12700	"0,06~ 0,10"	15000	"0,09~ 0,12"	2100	"0,03~ 0,06"
4	4	9600	"0,08~ 0,12"	9600	"0,08~ 0,12"	5600	"0,08~ 0,12"	4000	"0,04~ 0,08"	9600	"0,08~ 0,12"	11100	"0,10~ 0,15"	1600	"0,04~ 0,07"
5	5	7600	"0,10~ 0,14"	7600	"0,10~ 0,14"	4500	"0,10~ 0,14"	3200	"0,05~ 0,10"	7600	"0,10~ 0,14"	9000	"0,10~ 0,14"	1250	"0,05~ 0,09"
6	6	6400	"0,11~ 0,16"	6400	"0,11~ 0,16"	3700	"0,11~ 0,16"	2700	"0,06~ 0,12"	6400	"0,11~ 0,16"	7400	"0,11~ 0,16"	1050	"0,06~ 0,11"
8	8	4800	"0,13~ 0,19"	4800	"0,13~ 0,19"	2800	"0,13~ 0,19"	2000	"0,08~ 0,16"	4800	"0,13~ 0,19"	5600	"0,13~ 0,19"	800	"0,08~ 0,14"
10	10	3800	"0,14~ 0,22"	3800	"0,14~ 0,22"	2200	"0,14~ 0,22"	1600	"0,10~ 0,18"	3800	"0,14~ 0,22"	4500	"0,14~ 0,22"	600	"0,10~ 0,16"
12	12	3200	"0,16~ 0,24"	3200	"0,16~ 0,24"	1900	"0,16~ 0,24"	1300	"0,12~ 0,20"	3200	"0,16~ 0,24"	3700	"0,16~ 0,24"	500	"0,12~ 0,18"
14	14	2700	"0,18~ 0,28"	2700	"0,18~ 0,28"	1600	"0,18~ 0,28"	1100	"0,13~ 0,22"	2700	"0,18~ 0,28"	3200	"0,18~ 0,28"	450	"0,13~ 0,20"
16	16	2400	"0,20~ 0,29"	2400	"0,20~ 0,29"	1400	"0,20~ 0,29"	1000	"0,14~ 0,25"	2400	"0,20~ 0,29"	2800	"0,20~ 0,29"	400	"0,14~ 0,23"
18	18	2100	"0,24~ 0,32"	2100	"0,24~ 0,32"	1200	"0,24~ 0,32"	880	"0,15~ 0,28"	2100	"0,24~ 0,32"	2500	"0,24~ 0,32"	350	"0,15~ 0,25"

1. Beim ersten Einsatz 90% der empfohlenen Schnittgeschwindigkeit oder 85% des Vorschubes wählen. Bei stabiler Bearbeitung die Schnittdaten entsprechend erhöhen.
2. Die obigen Schnittdatenempfehlungen basieren auf dem Einsatz von Emulsion.
3. Keine defekte Werkzeugaufnahme wählen. Die Rundlaufgenauigkeit muss unter 0,02mm liegen.
4. Die obigen Schnittdaten sind für Bohrungstiefen unter 8xD ausgelegt.

1. When the tool is used for the first time, please make a test cutting with 90% of cutting speed or 85% feed rate mentioned above. If the cutting conditions remain stable, gradually increase the cutting speed and feed rate.
2. The cutting conditions above are for drilling with emulsion.
3. Use a collet without any defect or dust. The radial run-out of drill must be under 0.02mm.
4. These conditions above are for cutting depth under 8D.

1. La première fois que vous utilisez sélectionner 90% de la vitesse de coupe recommandée ou 85% de l'alimentation. Avec stable traitement des données de coupe augmentent en conséquence.
2. Les recommandations de données de coupe ci-dessus sont basées sur l'utilisation de l'émulsion.
3. Ne composez jamais un porte-outil défectueux. La concentricité doit être inférieure à 0,02 mm.
4. Les données ci-dessus en coupe sont conçus pour des profondeurs de forage sous 8xD.



VHM NC Maschinenreibahlen H7 für Durchgangsbohrungen

Solid carbide NC machine reamers H7 for through holes
Carbure Alésoir NC machine H7 trou de passage

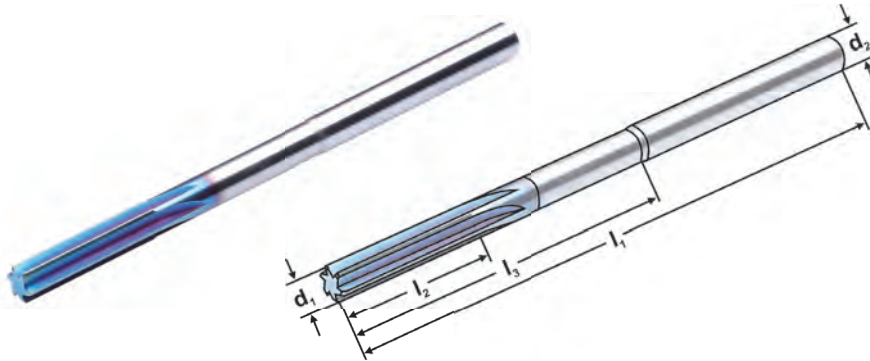

H 7	AlTiCrN HX
≤ 65 HRC	MG Carbide
Form A	

P	H	M	K	N	S
●	●	○	●	○	○

Bestell Nr. Order no. Référence	d ₁ H7	l ₂	l ₃	l ₁	d ₂	Zähne Teeth dent
RS600.0100	1,00	6,00	20,00	60,00	3,00	3
RS600.0197	1,97	15,00	30,00	60,00	3,00	4
RS600.0198	1,98	15,00	30,00	60,00	3,00	4
RS600.0199	1,99	15,00	30,00	60,00	3,00	4
RS600.0200	2,00	15,00	30,00	60,00	3,00	4
RS600.0201	2,01	15,00	30,00	60,00	3,00	4
RS600.0202	2,02	15,00	30,00	60,00	3,00	4
RS600.0203	2,03	15,00	30,00	60,00	3,00	4
RS600.0296	2,96	15,00	30,00	60,00	3,00	4
RS600.0297	2,97	15,00	30,00	60,00	3,00	4
RS600.0298	2,98	15,00	30,00	60,00	3,00	4
RS600.0299	2,99	15,00	30,00	60,00	3,00	4
RS600.0300	3,00	15,00	30,00	60,00	3,00	4
RS600.0301	3,01	15,00	30,00	60,00	3,00	4
RS600.0302	3,02	15,00	30,00	60,00	3,00	4
RS600.0303	3,03	15,00	30,00	60,00	3,00	4
RS600.0304	3,04	15,00	30,00	60,00	3,00	4
RS600.0305	3,05	15,00	30,00	60,00	3,00	4
RS600.0396	3,96	18,00	40,00	80,00	6,00	4
RS600.0397	3,97	18,00	40,00	80,00	6,00	4
RS600.0398	3,98	18,00	40,00	80,00	6,00	4
RS600.0399	3,99	18,00	40,00	80,00	6,00	4
RS600.0400	4,00	18,00	40,00	80,00	6,00	4
RS600.0401	4,01	18,00	40,00	80,00	6,00	4
RS600.0402	4,02	18,00	40,00	80,00	6,00	4
RS600.0403	4,03	18,00	40,00	80,00	6,00	4
RS600.0404	4,04	18,00	40,00	80,00	6,00	4
RS600.0405	4,05	18,00	40,00	80,00	6,00	4
RS600.0497	4,97	26,00	60,00	100,00	6,00	6
RS600.0498	4,98	26,00	60,00	100,00	6,00	6
RS600.0499	4,99	26,00	60,00	100,00	6,00	6

Bestell Nr. Order no. Référence	d ₁ H7	l ₂	l ₃	l ₁	d ₂	Zähne Teeth dent
RS600.0500	5,00	26,00	60,00	100,00	6,00	6
RS600.0501	5,01	26,00	60,00	100,00	6,00	6
RS600.0502	5,02	26,00	60,00	100,00	6,00	6
RS600.0503	5,03	26,00	60,00	100,00	6,00	6
RS600.0596	5,96	26,00	60,00	100,00	6,00	6
RS600.0597	5,97	26,00	60,00	100,00	6,00	6
RS600.0598	5,98	26,00	60,00	100,00	6,00	6
RS600.0599	5,99	26,00	60,00	100,00	6,00	6
RS600.0600	6,00	26,00	60,00	100,00	6,00	6
RS600.0601	6,01	26,00	60,00	100,00	6,00	6
RS600.0602	6,02	26,00	60,00	100,00	6,00	6
RS600.0603	6,03	26,00	60,00	100,00	6,00	6
RS600.0797	7,97	36,00	75,00	118,00	8,00	6
RS600.0798	7,98	36,00	75,00	118,00	8,00	6
RS600.0799	7,99	36,00	75,00	118,00	8,00	6
RS600.0800	8,00	36,00	75,00	118,00	8,00	6
RS600.0801	8,01	36,00	75,00	118,00	8,00	6
RS600.0802	8,02	36,00	75,00	118,00	8,00	6
RS600.0803	8,03	36,00	75,00	118,00	8,00	6
RS600.0997	9,97	36,00	90,00	135,00	10,00	6
RS600.0998	9,98	36,00	90,00	135,00	10,00	6
RS600.0999	9,99	36,00	90,00	135,00	10,00	6
RS600.1000	10,00	36,00	90,00	135,00	10,00	6
RS600.1001	10,01	36,00	90,00	135,00	10,00	6
RS600.1002	10,02	36,00	90,00	135,00	10,00	6
RS600.1003	10,03	36,00	90,00	135,00	10,00	6
RS600.1197	11,97	45,00	100,00	150,00	12,00	6
RS600.1198	11,98	45,00	100,00	150,00	12,00	6
RS600.1199	11,99	45,00	100,00	150,00	12,00	6
RS600.1200	12,00	45,00	100,00	150,00	12,00	6
RS600.1201	12,01	45,00	100,00	150,00	12,00	6
RS600.1202	12,02	45,00	100,00	150,00	12,00	6
RS600.1203	12,03	45,00	100,00	150,00	12,00	6

Schnittdaten

Cutting data

Données de coupe

Materialgruppen Material groups Groupes matières	P		H				K			
	Wenig legierter Stahl <1400 N/mm Low-alloyed steel <1400 N/mm Acier faible allié <1400N/mm		Stahl 45-55HRC Steel 45-55HRC Acier 45-55HRC		Stahl 55-60 HRC Steel 55-60 HRC Acier 55-60 HRC		Stahl 60-65 HRC Steel 60-65 HRC Acier 60-65 HRC		Gusseisen Cast Iron Fonte	
Vc m/min	8-15		8-10		6-8		4-6		15-20	
f mm/U 1,0-2,99	0,025	0,035	0,030	0,050	0,020	0,030	0,020	0,030	0,060	0,090
f mm/U 3,0-5,99	0,035	0,090	0,050	0,120	0,030	0,075	0,030	0,075	0,090	0,180
f mm/U 6,0-7,99	0,090	0,100	0,120	0,150	0,075	0,090	0,075	0,090	0,180	0,250
f mm/U 8,0-9,99	0,100	0,120	0,150	0,160	0,090	0,100	0,090	0,100	0,250	0,260
f mm/U 10,0-12,0	0,120	0,140	0,160	0,170	0,100	0,110	0,100	0,110	0,260	0,280



VHM NC Maschinenreibahlen für Sacklochbohrungen

Solid carbide NC machine reamers for blind holes
Carbure Alésoir NC machine filetage trou borgne

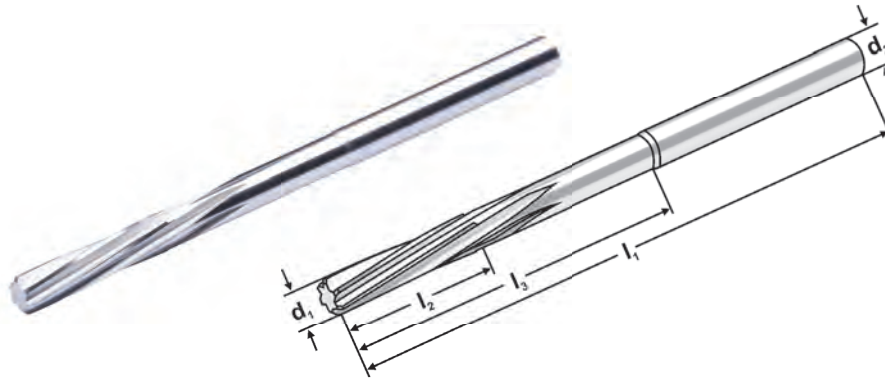

MG
Carbide

Tol.
0/+0,005

Coating
Blank

Form
B



P	H	M	K	N	S
●	●	○	●	○	○

Bestell Nr. Order no. Référence	0/+0,005 d ₁ H7	l ₂	l ₃	l ₁	d ₂	Zähne Teeth dent
RS700.0095	0,95	10,00	25,00	50,00	3,00	4
RS700.0096	0,96	10,00	25,00	50,00	3,00	4
RS700.0097	0,97	10,00	25,00	50,00	3,00	4
RS700.0098	0,98	10,00	25,00	50,00	3,00	4
RS700.0099	0,99	10,00	25,00	50,00	3,00	4
RS700.0100	1,00	10,00	25,00	50,00	3,00	4
RS700.0101	1,01	10,00	25,00	50,00	3,00	4
RS700.0102	1,02	10,00	25,00	50,00	3,00	4
RS700.0103	1,03	10,00	25,00	50,00	3,00	4
RS700.0104	1,04	10,00	25,00	50,00	3,00	4
RS700.0105	1,05	10,00	25,00	50,00	3,00	4
RS700.0195	1,95	10,00	25,00	60,00	3,00	4
RS700.0196	1,96	10,00	25,00	60,00	3,00	4
RS700.0197	1,97	10,00	25,00	60,00	3,00	4
RS700.0198	1,98	10,00	25,00	60,00	3,00	4
RS700.0199	1,99	10,00	25,00	60,00	3,00	4
RS700.0200	2,00	10,00	25,00	60,00	3,00	4
RS700.0201	2,01	10,00	25,00	60,00	3,00	4
RS700.0202	2,02	10,00	25,00	60,00	3,00	4
RS700.0203	2,03	10,00	25,00	60,00	3,00	4
RS700.0204	2,04	10,00	25,00	60,00	3,00	4
RS700.0205	2,05	10,00	25,00	60,00	3,00	4
RS700.0295	2,95	18,00	30,00	60,00	3,00	4
RS700.0296	2,96	18,00	30,00	60,00	3,00	4
RS700.0297	2,97	18,00	30,00	60,00	3,00	4
RS700.0298	2,98	18,00	30,00	60,00	3,00	4
RS700.0299	2,99	18,00	30,00	60,00	3,00	4
RS700.0300	3,00	18,00	30,00	60,00	3,00	4
RS700.0301	3,01	18,00	30,00	60,00	3,00	4
RS700.0302	3,02	18,00	30,00	60,00	3,00	4
RS700.0303	3,03	18,00	30,00	60,00	3,00	4

Bestell Nr. Order no. Référence	0/+0,005 d ₁ H7	l ₂	l ₃	l ₁	d ₂	Zähne Teeth dent
RS700.0304	3,04	18,00	30,00	60,00	3,00	4
RS700.0305	3,05	18,00	30,00	60,00	3,00	4
RS700.0395	3,95	18,00	40,00	80,00	6,00	6
RS700.0396	3,96	18,00	40,00	80,00	6,00	6
RS700.0397	3,97	18,00	40,00	80,00	6,00	6
RS700.0398	3,98	18,00	40,00	80,00	6,00	6
RS700.0399	3,99	18,00	40,00	80,00	6,00	6
RS700.0400	4,00	18,00	40,00	80,00	6,00	6
RS700.0401	4,01	18,00	40,00	80,00	6,00	6
RS700.0402	4,02	18,00	40,00	80,00	6,00	6
RS700.0403	4,03	18,00	40,00	80,00	6,00	6
RS700.0404	4,04	18,00	40,00	80,00	6,00	6
RS700.0405	4,05	18,00	40,00	80,00	6,00	6
RS700.0495	4,95	26,00	60,00	100,00	6,00	6
RS700.0496	4,96	26,00	60,00	100,00	6,00	6
RS700.0497	4,97	26,00	60,00	100,00	6,00	6
RS700.0498	4,98	26,00	60,00	100,00	6,00	6
RS700.0499	4,99	26,00	60,00	100,00	6,00	6
RS700.0500	5,00	26,00	60,00	100,00	6,00	6
RS700.0501	5,01	26,00	60,00	100,00	6,00	6
RS700.0502	5,02	26,00	60,00	100,00	6,00	6
RS700.0503	5,03	26,00	60,00	100,00	6,00	6
RS700.0504	5,04	26,00	60,00	100,00	6,00	6
RS700.0505	5,05	26,00	60,00	100,00	6,00	6
RS700.0595	5,95	26,00	60,00	108,00	6,00	6
RS700.0596	5,96	26,00	60,00	108,00	6,00	6
RS700.0597	5,97	26,00	60,00	108,00	6,00	6
RS700.0598	5,98	26,00	60,00	108,00	6,00	6
RS700.0599	5,99	26,00	60,00	108,00	6,00	6
RS700.0600	6,00	26,00	60,00	108,00	6,00	6
RS700.0601	6,01	26,00	60,00	108,00	6,00	6
RS700.0602	6,02	26,00	60,00	108,00	6,00	6
RS700.0603	6,03	26,00	60,00	108,00	6,00	6
RS700.0604	6,04	26,00	60,00	108,00	6,00	6
RS700.0605	6,05	26,00	60,00	108,00	6,00	6
RS700.0695	6,95	36,00	75,00	118,00	8,00	6
RS700.0696	6,96	36,00	75,00	118,00	8,00	6
RS700.0697	6,97	36,00	75,00	118,00	8,00	6
RS700.0698	6,98	36,00	75,00	118,00	8,00	6
RS700.0699	6,99	36,00	75,00	118,00	8,00	6
RS700.0700	7,00	36,00	75,00	118,00	8,00	6
RS700.0701	7,01	36,00	75,00	118,00	8,00	6
RS700.0702	7,02	36,00	75,00	118,00	8,00	6
RS700.0703	7,03	36,00	75,00	118,00	8,00	6
RS700.0704	7,04	36,00	75,00	118,00	8,00	6
RS700.0705	7,05	36,00	75,00	118,00	8,00	6
RS700.0795	7,95	36,00	75,00	118,00	8,00	6
RS700.0796	7,96	36,00	75,00	118,00	8,00	6
RS700.0797	7,97	36,00	75,00	118,00	8,00	6
RS700.0798	7,98	36,00	75,00	118,00	8,00	6
RS700.0799	7,99	36,00	75,00	118,00	8,00	6

Bestell Nr. Order no. Référence	0/+0,005 d ₁ H7	l ₂	l ₃	l ₁	d ₂	Zähne Teeth dent
RS700.0800	8,00	36,00	75,00	118,00	8,00	6
RS700.0801	8,01	36,00	75,00	118,00	8,00	6
RS700.0802	8,02	36,00	75,00	118,00	8,00	6
RS700.0803	8,03	36,00	75,00	118,00	8,00	6
RS700.0804	8,04	36,00	75,00	118,00	8,00	6
RS700.0805	8,05	36,00	75,00	118,00	8,00	6
RS700.0895	8,95	36,00	90,00	135,00	10,00	6
RS700.0896	8,96	36,00	90,00	135,00	10,00	6
RS700.0897	8,97	36,00	90,00	135,00	10,00	6
RS700.0898	8,98	36,00	90,00	135,00	10,00	6
RS700.0899	8,99	36,00	90,00	135,00	10,00	6
RS700.0900	9,00	36,00	90,00	135,00	10,00	6
RS700.0901	9,01	36,00	90,00	135,00	10,00	6
RS700.0902	9,02	36,00	90,00	135,00	10,00	6
RS700.0903	9,03	36,00	90,00	135,00	10,00	6
RS700.0904	9,04	36,00	90,00	135,00	10,00	6
RS700.0905	9,05	36,00	90,00	135,00	10,00	6
RS700.0995	9,95	36,00	90,00	135,00	10,00	6
RS700.0996	9,96	36,00	90,00	135,00	10,00	6
RS700.0997	9,97	36,00	90,00	135,00	10,00	6
RS700.0998	9,98	36,00	90,00	135,00	10,00	6
RS700.0999	9,99	36,00	90,00	135,00	10,00	6
RS700.1000	10,00	36,00	90,00	135,00	10,00	6
RS700.1001	10,01	36,00	90,00	135,00	10,00	6
RS700.1002	10,02	36,00	90,00	135,00	10,00	6
RS700.1003	10,03	36,00	90,00	135,00	10,00	6
RS700.1004	10,04	36,00	90,00	135,00	10,00	6
RS700.1005	10,05	36,00	90,00	135,00	10,00	6
RS700.1095	10,95	45,00	105,00	150,00	12,00	6
RS700.1096	10,96	45,00	105,00	150,00	12,00	6
RS700.1097	10,97	45,00	105,00	150,00	12,00	6
RS700.1098	10,98	45,00	105,00	150,00	12,00	6
RS700.1099	10,99	45,00	105,00	150,00	12,00	6
RS700.1100	11,00	45,00	105,00	150,00	12,00	6
RS700.1101	11,01	45,00	105,00	150,00	12,00	6
RS700.1102	11,02	45,00	105,00	150,00	12,00	6
RS700.1103	11,03	45,00	105,00	150,00	12,00	6
RS700.1104	11,04	45,00	105,00	150,00	12,00	6
RS700.1105	11,05	45,00	105,00	150,00	12,00	6
RS700.1195	11,95	45,00	105,00	150,00	12,00	6
RS700.1196	11,96	45,00	105,00	150,00	12,00	6
RS700.1197	11,97	45,00	105,00	150,00	12,00	6
RS700.1198	11,98	45,00	105,00	150,00	12,00	6
RS700.1199	11,99	45,00	105,00	150,00	12,00	6
RS700.1200	12,00	45,00	105,00	150,00	12,00	6
RS700.1201	12,01	45,00	105,00	150,00	12,00	6
RS700.1202	12,02	45,00	105,00	150,00	12,00	6
RS700.1203	12,03	45,00	105,00	150,00	12,00	6
RS700.1204	12,04	45,00	105,00	150,00	12,00	6
RS700.1205	12,05	45,00	105,00	150,00	12,00	6

Cutting data

Données de coupe

Materialgruppen Material groups Groupes matières		Vc m/min	f mm/U Ø 0,1-2,99	f mm/U Ø 3,0-5,99	f mm/U Ø 6,0-9,99	f mm/U Ø 10,0-15,99	f mm/U Ø 16,0-20,0
P	Legierter Stahl <500 N/mm <i>Alloyed steel <500 N/mm</i> Acier allié <500 N/mm	30-40	0,080-0,100	0,100-0,150	0,150-0,200	0,200-0,250	0,250-0,300
	Legierter Stahl <700 N/mm <i>Alloyed steel <700 N/mm</i> Acier allié <700 N/mm	25-35	0,080-0,100	0,100-0,150	0,150-0,200	0,200-0,250	0,250-0,300
	Legierter Stahl <850 N/mm <i>Alloyed steel <850 N/mm</i> Acier allié <850 N/mm	25-35	0,080-0,100	0,100-0,150	0,150-0,200	0,200-0,250	0,250-0,300
	Legierter Stahl <1000 N/mm <i>Alloyed steel <1000 N/mm</i> Acier allié <1000 N/mm	25-35	0,600-0,080	0,080-0,100	0,100-0,140	0,140-0,200	0,200-0,300
	Legierter Stahl <1400 N/mm <i>Alloyed steel <1400 N/mm</i> Acier allié <1400 N/mm	10-15	0,060-0,080	0,080-0,100	0,100-0,140	0,140-0,200	0,200-0,300
M	Edelstahl <i>Stainless Steel</i> Acier inoxydable	10-15	0,060-0,080	0,080-0,100	0,100-0,140	0,140-0,200	0,200-0,300
K	Gusseisen <i>Cast Iron</i> Fonte	12-20	0,120-0,180	0,180-0,200	0,200-0,230	0,230-0,300	0,300-0,350
N	Kupfer <i>Copper</i> Cuivre	20-30	0,150-0,200	0,200-0,250	0,250-0,320	0,320-0,400	0,400-0,450
S	Titanium <i>Titanium</i> Titane	5-10	0,060-0,080	0,080-0,100	0,100-0,140	0,140-0,200	0,200-0,300



Schafteckfräser 90°

End mill cutter 90° Fraise à queue 90°

- Für ISO Fräswendeplatten APKT 1003... / APHX 1003...
- Innere Kühlmittelzufuhr
- Vernickelt
- Schaft nach DIN 1835B
- Für den Einsatz in allen Werkstoffen
- Lieferumfang: Ohne Wendeschneidplatten

- For ISO Inserts APKT 1003... / APHX 1003...
- With internal cooling
- Nickel plated
- Shank after DIN 1835B
- Application in all materials
- Delivery: without inserts

- Pour plaquettes ISO AKPT 1003,... / APHX 1003,...
- Arrosage centrale
- Nickelé
- Queue selon DIN 1835 B
- Pour utilisation dans toutes les matériaux
- Livraison: sans plaquettes

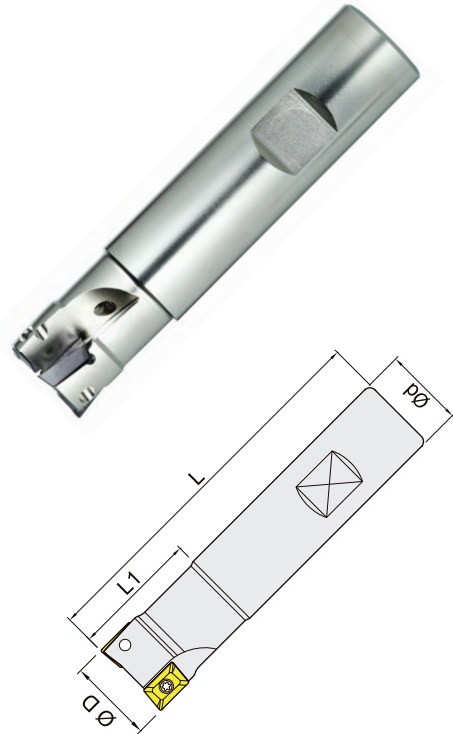

Bestell Nr. Order no. Référence	D	d	L	L1	Schneiden Inserts Plaquettes
G.10.10	10	16	80	24	1
G.10.L.10	10	16	150	24	1
G.10.12	12	16	80	24	1
G.10.L.12	12	16	150	24	1
G.10.14	14	16	80	24	1
G.10.15	15	16	85	25	2
G.10.15.7	15,7	16	85	25	2
G.10.16	16	16	85	25	2
G.10.L.16	16	16	150	24	2
G.10.18	18	20	85	25	2
G.10.19.7	19,7	20	90	25	3
G.10.20	20	20	90	25	3
G.10.L.20	20	20	150	25	3
G.10.22	22	25	95	25	3
G.10.24.7	24,7	25	95	25	4
G.10.25	25	25	95	25	4
G.10.L.25	25	25	150	25	4
G.10.28	28	25	95	25	4
G.10.30	30	25	95	25	4
G.10.32	32	25	95	26	5
G.10.L.32	32	25	150	26	5



101.TX8
Torx Klemmschrauben
Torx clamping screw
Torx



02.TX8
Torx-Schraubendreher TX8
Torx screwdriver TX8
Tournevis Torx TX8

Angular milling cutter 90° Fraise à coin 90°

- Für ISO Fräswendepplatten APKT 1003... / APHX 1003...
- Innere Kühlmittelzufuhr
- Vernickelt
- Für den Einsatz in allen Werkstoffen
- Lieferumfang: Ohne Wendeschneidplatten

- For ISO Inserts APKT 1003... / APHX 1003...
- With internal cooling
- Nickel plated
- Application in all materials
- Delivery: without inserts

- Pour plaquettes ISO AKPT 1003,... / APHX 1003,...
- Arrosage centrale
- Nickelé
- Pour utilisation dans toutes les matériaux
- Livraison: sans plaquettes

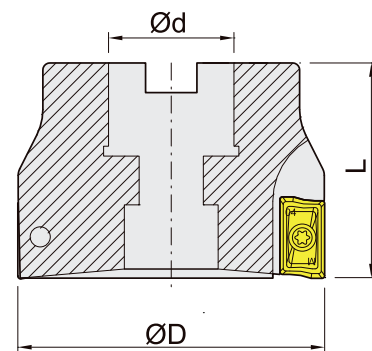

Bestell Nr. Order no. Référence	D	d	L	Schneiden Inserts Plaquettes
G.11.40	40	16	40	6
G.11.50	50	22	40	7
G.11.63	63	22	40	8
G.11.80	80	27	50	11
G.11.100	100	32	50	12

Einschraubfräser 90°

Screw-In cutter 90° Fraise à queue filetée 90°

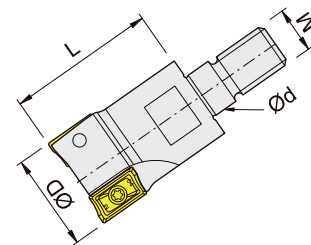

Bestell Nr. Order no. Référence	D	d	L	M	Schneiden Inserts Plaquettes
G.20.10	10	10	20	M6	1
G.20.12	12	10	20	M6	1
G.20.16	16	10	25	M8	2
G.20.20	20	10	30	M10	3
G.20.25	25	10	35	M12	3
G.20.25.1	25	10	35	M12	4
G.20.32	32	10	43	M16	5



101.TX8
Torx Klemmschrauben
Torx clamping screw
Torx



02.TX8
Torx-Schraubendreher TX8
Torx screwdriver TX8
Tournevis Torx TX8



Schafteckfräser 90°

End mill cutter 90° Fraise à queue 90°

- Für ISO Fräswendeplatten APKT 1604... / APHX 1604...
- Innere Kühlmittelzufuhr
- Vernickelt
- Schaft nach DIN 1835B
- Für den Einsatz in allen Werkstoffen
- Lieferumfang: Ohne Wendeschneidplatten

- For ISO Inserts APKT 1604... / APHX 1604...
- With internal cooling
- Nickel plated
- Shank after DIN 1835B
- Application in all materials
- Delivery: without inserts

- Pour plaquettes ISO APKT 1604... / APHX 1604...
- Arrosage centrale
- Nickelé
- Queue selon DIN 1835 B
- Pour utilisation dans toutes les matériaux
- Livraison: sans plaquettes

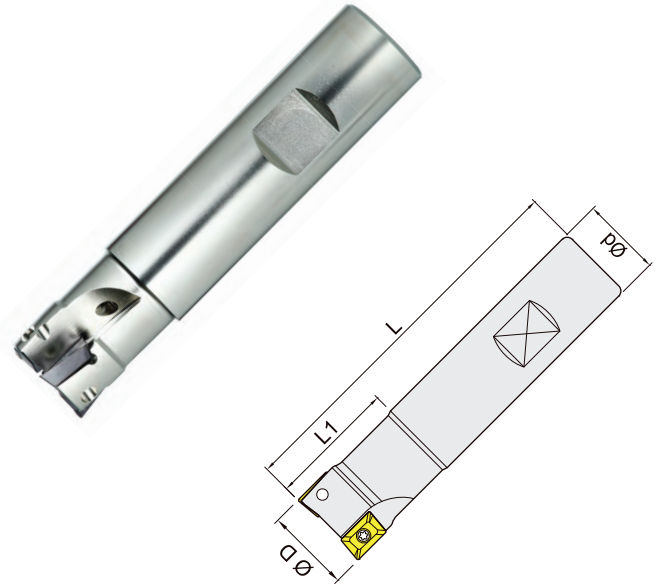

Bestell Nr. Order no. Référence	D	d	L	L1	Schneiden Inserts Plaquettes
G.12.25	25	25	100	44	2
G.12.32	32	32	110	50	3
G.12.40	40	32	115	45	4
G.12.L.22	22	20	200	60	2
G.12.L.25	25	25	200	60	2
G.12.L.32	32	32	200	60	3
G.12.L.40	40	32	200	60	4

Einschraubfräser 90°

Screw-In cutter 90° Fraise à queue fileté 90°

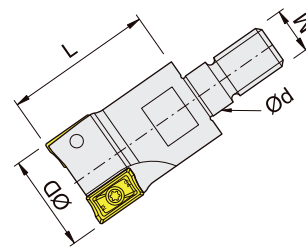

Bestell Nr. Order no. Référence	D	d	L	M	Schneiden Inserts Plaquettes
G.21.32	32	17	46	M16	3
G.21.40	40	17	46	M16	4



101.TX15
Torx Klemmschrauben
Torx clamping screw
Torx



02.TX15
Torx-Schraubendreher TX15
Torx screwdriver TX15
Tournevis Torx TX15

Angular milling cutter 90° Fraise à coin 90°

- Für ISO Fräswendeplatten APKT 1604... / APHX 1604...
- Innere Kühlmittelzufuhr
- Vernickelt
- Für den Einsatz in allen Werkstoffen
- Lieferumfang: Ohne Wendeschneidplatten

- For ISO Inserts APKT 1604... / APHX 1604...
- With internal cooling
- Nickel plated
- Application in all materials
- Delivery: without inserts

- Pour plaquettes ISO APKT 1604... / APHX 1604...
- Arrosage centrale
- Nickelé
- Pour utilisation dans toutes les matériaux
- Livraison: sans plaquettes

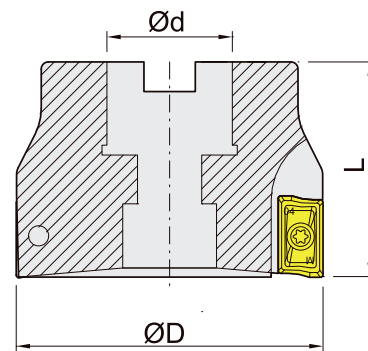

Bestell Nr. Order no. Référence	D	d	L	Schneiden Inserts Plaquettes
G.13.40	40	16	40	4
G.13.50	50	22	40	5
G.13.63	63	22	40	6
G.13.80	80	27	50	7
G.13.100	100	32	50	8
G.13.125	125	40	63	9
G.13.160**	160	40	63	10

** ohne Innenkühlung / Without internal cooling / sans arrosage centrale



101.TX15
Torx Klemmschrauben
Torx clamping screw
Torx



02.TX15
Torx-Schraubendreher TX15
Torx screwdriver TX15
Tournevis Torx TX15



Planfräser 45°

Face milling cutter 45°
Fraise de face 45°

- Für ISO Fräswendeplatten SEKT 1204... / SEHX 1204...
- Innere Kühlmittelzufuhr
- Vernickelt
- Für den Einsatz in allen Werkstoffen
- Lieferumfang: Ohne Wendeschneidplatten

- For ISO Inserts SEKT 1204... / SEHX 1204...
- With internal cooling
- Nickel plated
- Application in all materials
- Delivery: without inserts

- Pour plaquettes ISO SEKT 1204... / SEHX 1204...
- Arrosage centrale
- Nickelé
- Pour utilisation dans toutes les matériaux
- Livraison: sans plaquettes

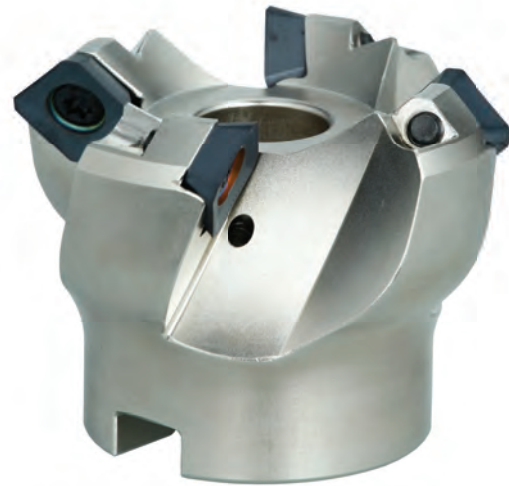
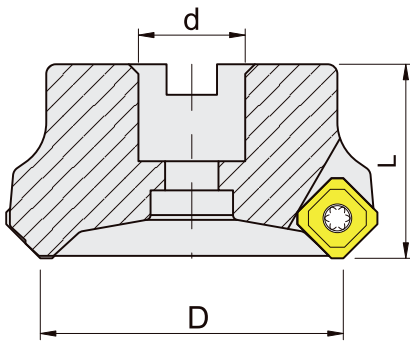

Bestell Nr. Order no. Référence	D	d	L	Schneiden Inserts Plaquettes
G.14.40	40	16	40	3
G.14.50	50	22	48	4
G.14.63	63	22	48	5
G.14.80	80	27	50	6
G.14.100	100	32	50	6
G.14.125	125	40	63	7
G.14.160	160	40	63	8

13



101.TX8
Torx Klemmschrauben
Torx clamping screw
Torx



02.TX8
Torx-Schraubendreher TX8
Torx screwdriver TX8
Tournevis Torx TX8

End mill cutter 75° Fraise à queue 75°

- Für ISO Fräswendeplatten APKT 1003... / APHX 1003...
- Innere Kühlmittelzufuhr
- Vernickelt
- Schaft nach DIN 1835B
- Für den Einsatz in allen Werkstoffen
- Lieferumfang: Ohne Wendeschneidplatten

- For ISO Inserts APKT 1003... / APHX 1003...
- With internal cooling
- Nickel plated
- Shank after DIN 1835B
- Application in all materials
- Delivery: without inserts

- Pour plaquettes ISO AKPT 1003,... / APHX 1003,...
- Arrosage centrale
- Nickelé
- Queue selon DIN 1835 B
- Pour utilisation dans toutes les matériaux
- Livraison: sans plaquettes

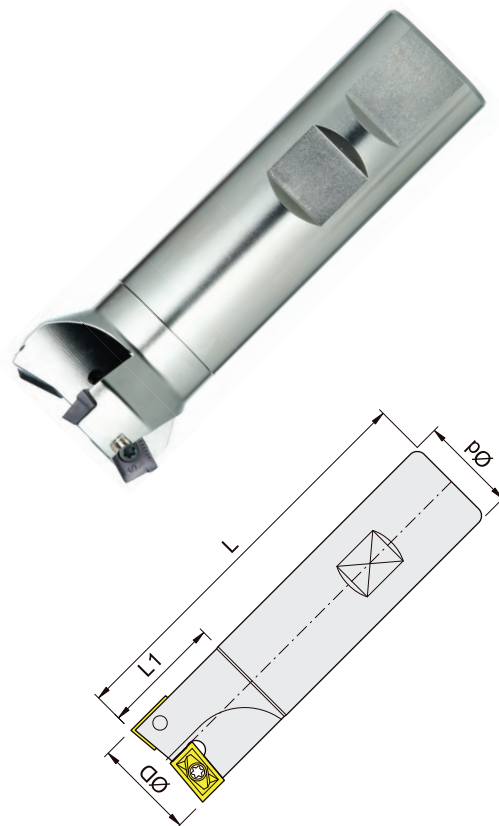

Bestell Nr. Order no. Référence	D	d	L	L1	Schneiden Inserts Plaquettes
G.15.25	25	20	95	25	2
G.15.32	32	25	95	25	3
G.15.40	40	25	100	25	4



101.TX8
Torx Klemmschrauben
Torx clamping screw
Torx



02.TX8
Torx-Schraubendreher TX8
Torx screwdriver TX8
Tournevis Torx TX8



Planfräser 75°

Face milling cutter 75°
Fraise de face 75°

- Für ISO Fräswendeplatten APKT 1003... / APHX 1003...
 - Innere Kühlmittelzufuhr
 - Vernickelt
 - Für den Einsatz in allen Werkstoffen
 - Lieferumfang: Ohne Wendeschneidplatten
- For ISO Inserts APKT 1003... / APHX 1003...
 - With internal cooling
 - Nickel plated
 - Application in all materials
 - Delivery: without inserts
- Pour plaquettes ISO AKPT 1003,... / APHX 1003,...
 - Arrosage centrale
 - Nickelé
 - Pour utilisation dans toutes les matériaux
 - Livraison: sans plaquettes

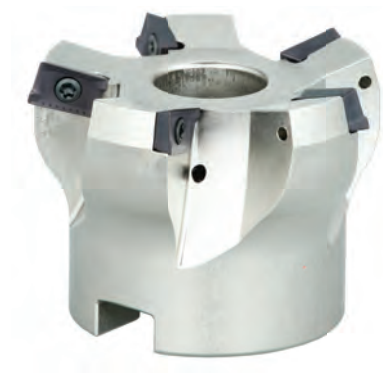
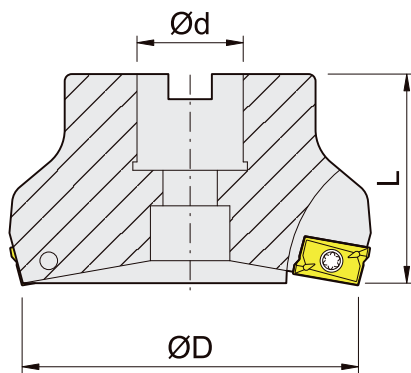

Bestell Nr. Order no. Référence	D	d	L	Schneiden Inserts Plaquettes
G.16.50	50	22	40	5
G.16.63	63	22	40	6

13



101.TX8
Torx Klemmschrauben
Torx clamping screw
Torx



02.TX8
Torx-Schraubendreher TX8
Torx screwdriver TX8
Tournevis Torx TX8

Face milling cutter 75° Fraise de face 75°

- Für ISO Fräswendeplatten APKT 1604... / APHX 1604...
- Innere Kühlmittelzufuhr
- Vernickelt
- Für den Einsatz in allen Werkstoffen
- Lieferumfang: Ohne Wendeschneidplatten

- *For ISO Inserts APKT 1604... / APHX 1604...*
- *With internal cooling*
- *Nickel plated*
- *Application in all materials*
- *Delivery: without inserts*

- Pour plaquettes ISO APKT 1604... / APHX 1604...
- Arrosage centrale
- Nickelé
- Pour utilisation dans toutes les matériaux
- Livraison: sans plaquettes

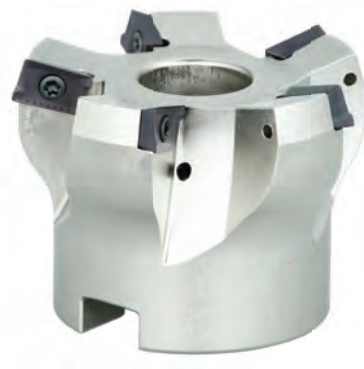
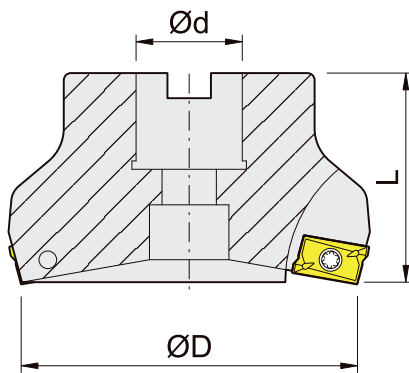

Bestell Nr. Order no. Référence	D	d	L	Schneiden Inserts Plaquettes
G.17.50	50	16	40	3
G.17.63	63	22	40	4
G.17.80	80	27	50	5
G.17.100	100	32	50	6
G.17.125	125	40	63	7



101.TX8
Torx Klemmschrauben
Torx clamping screw
Torx



02.TX8
Torx-Schraubendreher TX8
Torx screwdriver TX8
Tournevis Torx TX8



Wendeschneidplatten APKT und APHX 1003...

Inserts APKT and APHX 1003...
Plaquettes APKT et APHX 1003...

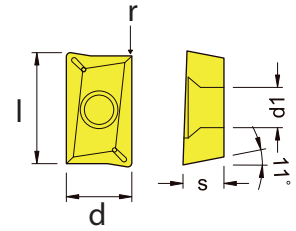
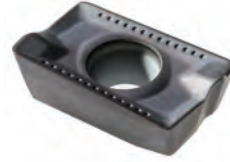

Wendeschneidplatten APKT 1003 PDER-S P200 für hartes Material

Inserts APKT 1003 PDER-S P200 for hard material

Plaquettes APKT 1003 PDER-S P200 pour matériau dur

Bestell Nr. Order no. Référence	Beschichtung Coating Revêtement	l	d	s	d1	r
1003.P200	P200 ISO P10-P20 / ISO K10-K20	10,5	6,7	3,5	2,8	0,5

Wendeschneidplatten APKT 1003 PDER-S P300 für rostfreies Material

Inserts APKT 1003 PDER-S P300 for stainless material

Plaquettes APKT 1003 PDER-S P300 pour matériau inoxydable

Bestell Nr. Order no. Référence	Beschichtung Coating Revêtement	l	d	s	d1	r
1003.P300	P300 ISO P30-P40 / ISO M30-M40	10,5	6,7	3,5	2,8	0,5

Wendeschneidplatten APKT 1003 PDER-S K300 für die allgemeine Bearbeitung

Inserts APKT 1003 PDER-S K300 for general processing

Plaquettes APKT 1003 PDER-S K300 pour l'usage général

Bestell Nr. Order no. Référence	Beschichtung Coating Revêtement	l	d	s	d1	r
1003.K300	K300 ISO P25-P40 / ISO M20-M40 / ISO K20-K40	10,5	6,7	3,5	2,8	0,5

Wendeschneidplatten APHX 100304 FR-Alu K15 für Aluminiumbearbeitung

Inserts APHX 100304 FR-Alu K15 for aluminium processing

Plaquettes APHX 100304 FR-Alu K15 pour l'usage d'aluminium

Bestell Nr. Order no. Référence	Beschichtung Coating Revêtement	l	d	s	d1	r
1003.KAlu	K15 ISO K15-K30	10,5	6,7	3,5	2,8	0,5

Wendeschneidplatten APKT und APHX 1604...



Inserts APKT and APHX 1604... Plaquettes APKT et APHX 1604...

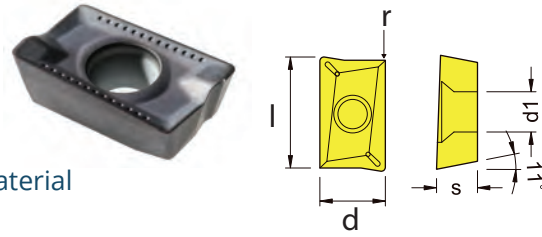

Wendeschneidplatten APKT 1604 PDER-S P200 für hartes Material
Inserts APKT 1604 PDER-S P200 for hard material
Plaquettes APKT 1604 PDER-S P200 pour matériau dur

Bestell Nr. Order no. Référence	Beschichtung Coating Revêtement	l	d	s	d1	r
1604.P200	P200 ISO P10-P20 / ISO K10-K20	17,00	9,45	5,26	4,40	0,80

Wendeschneidplatten APKT 1604 PDER-S P300 für rostfreies Material
Inserts APKT 1604 PDER-S P300 for stainless material
Plaquettes APKT 1604 PDER-S P300 pour matériau inoxydable

Bestell Nr. Order no. Référence	Beschichtung Coating Revêtement	l	d	s	d1	r
1604.P300	P300 ISO P30-P40 / ISO M30-M40	17,00	9,45	5,26	4,40	0,80

Wendeschneidplatten APKT 1604 PDER-S K300 für die allgemeine Bearbeitung
Inserts APKT 1604 PDER-S K300 for general processing
Plaquettes APKT 1604 PDER-S K300 pour l'usage général

Bestell Nr. Order no. Référence	Beschichtung Coating Revêtement	l	d	s	d1	r
1604.K300	K300 ISO P25-P40 / ISO M20-M40 / ISO K20-K40	17,00	9,45	5,26	4,40	0,80

Wendeschneidplatten APHX 160404 FR-Alu K15 für Aluminiumbearbeitung
Inserts APHX 160404 FR-Alu K15 for aluminium processing
Plaquettes APHX 160404 FR-Alu K15 pour l'usage d'aluminium

Bestell Nr. Order no. Référence	Beschichtung Coating Revêtement	l	d	s	d1	r
1604.KAlu	K15 ISO K15-K30	17,00	9,52	4,76	4,4	0,40

Wendeschneidplatten SEKT und SEHX 1204...

Inserts SEKT and SEHX 1204... Plaquettes SEKT et SEHX 1204...

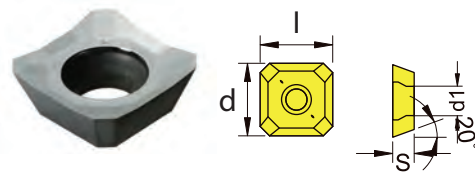

Wendeschneidplatten SEKT 1204 für die allgemeine Bearbeitung
Inserts SEKT 1204 for general processing
Plaquettes SEKT 1204 pour l'usage général

Bestell Nr. Order no. Référence	Beschichtung Coating Revêtement	l	d	s	d1	r
SEKT.K300	K300 ISO P25-P40 / ISO M20-M40 / ISO K20-K40	12,7	12,7	4,76	5,50	-

Wendeschneidplatten SEHX 1204 für Aluminiumbearbeitung
Inserts SEHX 1204 for aluminium processing
Plaquettes SEHX 1204 pour l'usage d'aluminium

Bestell Nr. Order no. Référence	Beschichtung Coating Revêtement	l	d	s	d1	r
SEHX.K15	K15 ISO K15-K30	12,7	12,7	4,76	5,50	-

K Stahl Bohrstangen SCLC L 06 links

Steel boring bars SCLC L 06 left
Barres d'alésage en acier SCLC L 06 à gauche

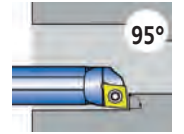

- Schwingungsarme Bohrstangen
- Mit Innenkühlung
- Längere Standzeit der Wendeschneidplatten
- Längsdrehen, sehr gut geeignet für enge Bohrungen
- Anstellwinkel: 95°
- Lieferumfang: Ohne Wendeschneidplatten

- *Low-vibration boring bars*
- *With internal cooling*
- *Longer durability of inserts*
- *For longitudinal and plane turning*
- *Setting angle: 95°*
- *Delivery: without inserts*

- Barres d'alésage à faibles vibrations
- Avec arrosage interne
- Longue durée de vie des plaquettes
- Tournage longitudinale, très bien adapté pour les trous serrés
- Angle d'incidence: 95°
- Livraison: sans plaquettes

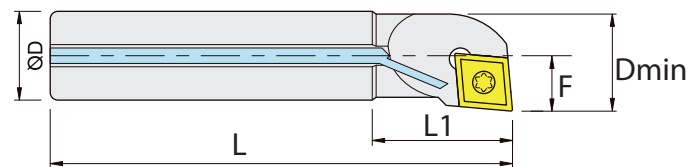

Bestell Nr. Order no. Référence	Wendepatte Inserts Plaquettes	ØD	F	L	L1	D _{min}
A0608H.SCLC.L06	CCMT / CCGT 0602...	8	4	100	25	8
A0810J.SCLC.L06	CCMT / CCGT 0602...	10	5	110	32	12
A1012K.SCLC.L06	CCMT / CCGT 0602...	12	6	125	38	14
A1216M.SCLC.L06	CCMT / CCGT 0602...	16	8	150	50	18

Stahl Bohrstangen Satz SCLC L 06 links
Steel boring bars set SCLC L 06 left
Set de barres d'alésage en acier SCLC L 06 à gauche

Bestell Nr. Order no. Référence	Satz beinhaltet Set consist of Set composé
SET.A.SCLC.L06	A0608H.SCLC.L06 A0810J.SCLC.L06 A1012K.SCLC.L06 A1216M.SCLC.L06



13



101.TX8
Torx Klemmschrauben
Torx clamping screw
Torx



02.TX8
Torx-Schraubendreher TX8
Torx screwdriver TX8
Tournevis Torx TX8

Stahl Bohrstangen SCLC R 06 rechts



Steel boring bars SCLC R 06 right
Barres d'alésage en acier SCLC R 06 droite

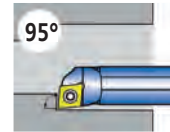

- Schwingungsarme Bohrstangen
- Mit Innenkühlung
- Längere Standzeit der Wendeschneidplatten
- Längsdrehen, sehr gut geeignet für enge Bohrungen
- Anstellwinkel: 95°
- Lieferumfang: Ohne Wendeschneidplatten

- *Low-vibration boring bars*
- *With internal cooling*
- *Longer durability of inserts*
- *For longitudinal and plane turning*
- *Setting angle: 95°*
- *Delivery: without inserts*

- Barres d'alésage à faibles vibrations
- Avec arrosage interne
- Longue durée de vie des plaquettes
- Tournage longitudinale, très bien adapté pour les trous serrés
- Angle d'incidence: 95°
- Livraison: sans plaquettes

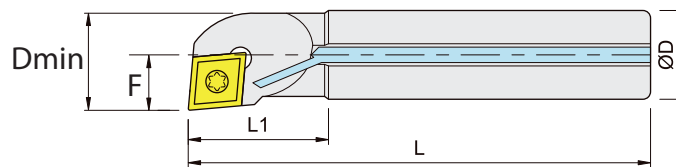

Bestell Nr. Order no. Référence	Wendeplatte Inserts Plaquettes	ØD	F	L	L1	D _{min}
A0608H.SCLC.R06	CCMT / CCGT 0602...	8	4	100	25	8
A0810J.SCLC.R06	CCMT / CCGT 0602...	10	5	110	32	12
A1012K.SCLC.R06	CCMT / CCGT 0602...	12	6	125	38	14
A1216M.SCLC.R06	CCMT / CCGT 0602...	16	8	150	50	18

Stahl Bohrstangen Satz SCLC R 06 rechts

Steel boring bars set SCLC R 06 right
Set de barres d'alésage en acier SCLC R 06 droite

Bestell Nr. Order no. Référence	Satz beinhaltet Set consist of Set composé
SET.A.SCLC.R06	A0608H.SCLC.R06 A0810J.SCLC.R06 A1012K.SCLC.R06 A1216M.SCLC.R06



101.TX8
Torx Klemmschrauben
Torx clamping screw
Torx



02.TX8
Torx-Schraubendreher TX8
Torx screwdriver TX8
Tournevis Torx TX8

K Stahl Bohrstangen SDUC L 07 links

Steel boring bars SDUC L 07 left
Barres d'alésage en acier SDUC L 07 à gauche

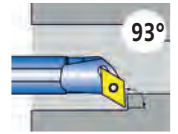

- Schwingungsarme Bohrstangen
- Mit Innenkühlung
- Längere Standzeit der Wendeschneidplatten
- Längsdrehen, sehr gut geeignet für enge Bohrungen
- Anstellwinkel: 93°
- Lieferumfang: Ohne Wendeschneidplatten

- *Low-vibration boring bars*
- *With internal cooling*
- *Longer durability of inserts*
- *For longitudinal and plane turning*
- *Setting angle: 93° Delivery: without inserts*

- Barres d'alésage à faibles vibrations
- Avec arrosage interne
- Longue durée de vie des plaquettes
- Tournage longitudinale, très bien adapté pour les trous serrés
- Angle d'incidence: 93°
- Livraison: sans plaquettes

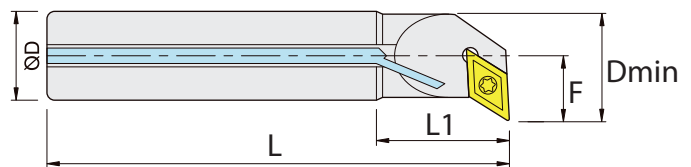

Bestell Nr. Order no. Référence	Wendepatte Inserts Plaquettes	ØD	F	F1	L	L1	Dmin
A0810H.SDUC.L07	DCMT-DCGT 0702..	10	7	5	100	22	12,5
A1012K.SDUC.L07	DCMT-DCGT 0702..	12	9	5	125	28	15,5
A1216M.SDUC.L07	DCMT-DCGT 0702..	16	11	5	150	36	19,5

Stahl Bohrstangen Satz SDUC L 07 links

Steel boring bars set SDUC L 07 left
Set de barres d'alésage en acier SDUC L 07 à gauche

Bestell Nr. Order no. Référence	Satz beinhaltet Set consist of Set composé
SET.A.SDUC.L07	A0810H.SDUC.L07 A1012K.SDUC.L07 A1216M.SDUC.L07



13



101.TX8
Torx Klemmschrauben
Torx clamping screw
Torx



02.TX8
Torx-Schraubendreher TX8
Torx screwdriver TX8
Tournevis Torx TX8

Stahl Bohrstangen SDUC R 07 rechts



Steel boring bars SDUC R 07 right Barres d'alésage en acier SDUC R 07 droite

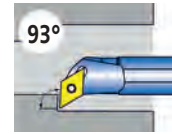

- Schwingungsarme Bohrstangen
- Mit Innenkühlung
- Längere Standzeit der Wendeschneidplatten
- Längsdrehen, sehr gut geeignet für enge Bohrungen
- Anstellwinkel: 93°
- Lieferumfang: Ohne Wendeschneidplatten

- *Low-vibration boring bars*
- *With internal cooling*
- *Longer durability of inserts*
- *For longitudinal and plane turning*
- *Setting angle: 93° Delivery: without inserts*

- Barres d'alésage à faibles vibrations
- Avec arrosage interne
- Longue durée de vie des plaquettes
- Tournage longitudinale, très bien adapté pour les trous serrés
- Angle d'incidence: 93°
- Livraison: sans plaquettes

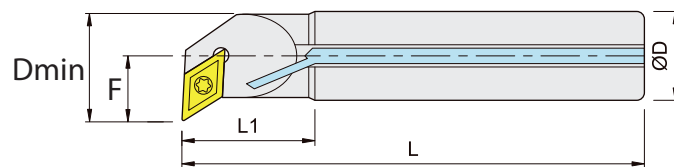

Bestell Nr. Order no. Référence	Wendepatte Inserts Plaquettes	ØD	F	F1	L	L1	Dmin
A0810H.SDUC.R07	DCMT-DCGT 0702..	10	7	5	100	22	12,5
A1012K.SDUC.R07	DCMT-DCGT 0702..	12	9	5	125	28	15,5
A1216M.SDUC.R07	DCMT-DCGT 0702..	16	11	5	150	36	19,5

Stahl Bohrstangen Satz SDUC R 07 rechts

Steel boring bars set SDUC R 07 right Set de barres d'alésage en acier SDUC R 07 droite

Bestell Nr. Order no. Référence	Satz beinhaltet Set consist of Set composé
SET.A.SDUC.R07	A0810H.SDUC.R07 A1012K.SDUC.R07 A1216M.SDUC.R07



101.TX8
Torx Klemmschrauben
Torx clamping screw
Torx



02.TX8
Torx-Schraubendreher TX8
Torx screwdriver TX8
Tournevis Torx TX8

K HSS Bohrstangen SCLC L 06 links

HSS boring bars SCLC L 06 left
Barres d'alésage HSS SCLC L 06 à gauche

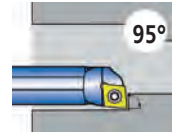

- Schwingungsarme Bohrstangen
- Mit Innenkühlung
- Längere Standzeit der Wendeschneidplatten
- Längsdrehen, sehr gut geeignet für enge Bohrungen
- Anstellwinkel: 95°
- Lieferumfang: Ohne Wendeschneidplatten

- Low-vibration boring bars
- With internal cooling
- Longer durability of inserts
- For longitudinal and plane turning
- Setting angle: 95°
- Delivery: without inserts

- Barres d'alésage à faibles vibrations
- Avec arrosage interne
- Longue durée de vie des plaquettes
- Tournage longitudinale, très bien adapté pour les trous serrés
- Angle d'incidence: 95°
- Livraison: sans plaquettes

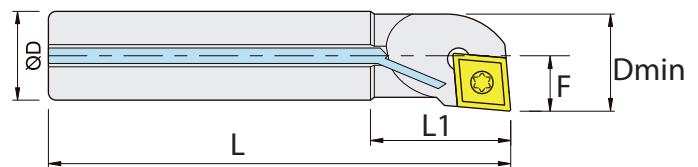

Bestell Nr. Order no. Référence	Wendepatte Inserts Plaquettes	ØD	F	L	L1	Dmin
AH0608H.SCLC.L06	CCMT / CCGT 0602...	8	4	100	25	8
AH0810J.SCLC.L06	CCMT / CCGT 0602...	10	5	110	32	12
AH1012K.SCLC.L06	CCMT / CCGT 0602...	12	6	125	38	14
AH1216M.SCLC.L06	CCMT / CCGT 0602...	16	8	150	50	18

HSS Bohrstangen Satz SCLC L 06 links

HSS boring bars set SCLC L 06 left
Set de barres d'alésage HSS SCLC L 06 à gauche

Bestell Nr. Order no. Référence	Satz beinhaltet Set consist of Set composé
SET.AH.SCLC.L06	AH0608H.SCLC.L06 AH0810J.SCLC.L06 AH1012K.SCLC.L06 AH1216M.SCLC.L06



13



101.TX8
Torx Klemmschrauben
Torx clamping screw
Torx



02.TX8
Torx-Schraubendreher TX8
Torx screwdriver TX8
Tournevis Torx TX8

HSS Bohrstangen SCLC R 06 rechts



HSS boring bars SCLC R 06 right
Barres d'alésage HSS SCLC R 06 droite

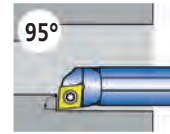

- Schwingungsarme Bohrstangen
- Mit Innenkühlung
- Längere Standzeit der Wendeschneidplatten
- Längsdrehen, sehr gut geeignet für enge Bohrungen
- Anstellwinkel: 95°
- Lieferumfang: Ohne Wendeschneidplatten

- *Low-vibration boring bars*
- *With internal cooling*
- *Longer durability of inserts*
- *For longitudinal and plane turning*
- *Setting angle: 95°*
- *Delivery: without inserts*

- Barres d'alésage à faibles vibrations
- Avec arrosage interne
- Longue durée de vie des plaquettes
- Tournage longitudinale, très bien adapté pour les trous serrés
- Angle d'incidence: 95°
- Livraison: sans plaquettes

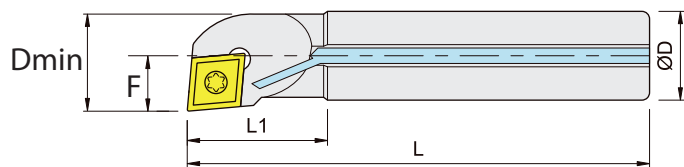

Bestell Nr. Order no. Référence	Wendepatte Inserts Plaquettes	ØD	F	L	L1	Dmin
AH0608H.SCLC.R06	CCMT / CCGT 0602...	8	4	100	25	8
AH0810J.SCLC.R06	CCMT / CCGT 0602...	10	5	110	32	12
AH1012K.SCLC.R06	CCMT / CCGT 0602...	12	6	125	38	14
AH1216M.SCLC.R06	CCMT / CCGT 0602...	16	8	150	50	18

HSS Bohrstangen Satz SCLC R 06 rechts

HSS boring bars set SCLC R 06 right
Set de barres d'alésage HSS SCLC R 06 droite

Bestell Nr. Order no. Référence	Satz beinhaltet Set consist of Set composé
SET.AH.SCLC.R06	AH0608H.SCLC.R06 AH0810J.SCLC.R06 AH1012K.SCLC.R06 AH1216M.SCLC.R06



101.TX8
 Torx Klemmschrauben
 Torx clamping screw
 Torx



02.TX8
 Torx-Schraubendreher TX8
 Torx screwdriver TX8
 Tournevis Torx TX8

K HSS Bohrstangen SDUC L 07 links

HSS boring bars SDUC L 07 left
Barres d'alésage HSS SDUC L 07 à gauche

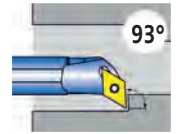

- Schwingungsarme Bohrstangen
 - Mit Innenkühlung
 - Längere Standzeit der Wendeschneidplatten
 - Längsdrehen, sehr gut geeignet für enge Bohrungen
 - Anstellwinkel: 93°
 - Lieferumfang: Ohne Wendeschneidplatten
- *Low-vibration boring bars*
 - *With internal cooling*
 - *Longer durability of inserts*
 - *For longitudinal and plane turning*
 - *Setting angle: 93°*
 - *Delivery: without inserts*
- Barres d'alésage à faibles vibrations
 - Avec arrosage interne
 - Longue durée de vie des plaquettes
 - Tournage longitudinale, très bien adapté pour les trous serrés
 - Angle d'incidence: 93°
 - Livraison: sans plaquettes

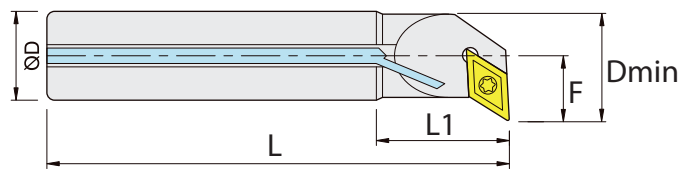

Bestell Nr. Order no. Référence	Wendepatte Inserts Plaquettes	ØD	F	F1	L	L1	Dmin
AH0810H.SDUC.L07	DCMT-DCGT 0702..	10	7	5	100	22	12,5
AH1012K.SDUC.L07	DCMT-DCGT 0702..	12	9	5	125	28	15,5
AH1216M.SDUC.L07	DCMT-DCGT 0702..	16	11	5	150	36	19,5

HSS Bohrstangen Satz SDUC L 07 links

HSS boring bars set SDUC L 07 left
Set de barres d'alésage HSS SDUC L 07 à gauche

Bestell Nr. Order no. Référence	Satz beinhaltet Set consist of Set composé
SET.AH.SDUC.L07	AH0810H.SDUC.L07 AH1012K.SDUC.L07 AH1216M.SDUC.L07



13



101.TX8
 Torx Klemmschrauben
 Torx clamping screw
 Torx



02.TX8
 Torx-Schraubendreher TX8
 Torx screwdriver TX8
 Tournevis Torx TX8

HSS Bohrstangen SDUC R 07 rechts



HSS boring bars SDUC R 07 right
Barres d'alésage HSS SDUC R 07 droite

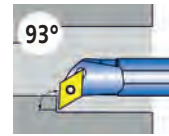

- Schwingungsarme Bohrstangen
- Mit Innenkühlung
- Längere Standzeit der Wendeschneidplatten
- Längsdrehen, sehr gut geeignet für enge Bohrungen
- Anstellwinkel: 93°
- Lieferumfang: Ohne Wendeschneidplatten

- *Low-vibration boring bars*
- *With internal cooling*
- *Longer durability of inserts*
- *For longitudinal and plane turning*
- *Setting angle: 93°*
- *Delivery: without inserts*

- Barres d'alésage à faibles vibrations
- Avec arrosage interne
- Longue durée de vie des plaquettes
- Tournage longitudinale, très bien adapté pour les trous serrés
- Angle d'incidence: 93°
- Livraison: sans plaquettes

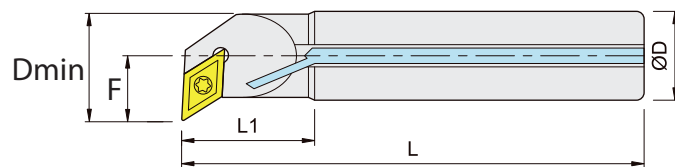

Bestell Nr. Order no. Référence	Wendepatte Inserts Plaquettes	ØD	F	F1	L	L1	Dmin
AH0810H.SDUC.R07	DCMT-DCGT 0702..	10	7	5	100	22	12,5
AH1012K.SDUC.R07	DCMT-DCGT 0702..	12	9	5	125	28	15,5
AH1216M.SDUC.R07	DCMT-DCGT 0702..	16	11	5	150	36	19,5

HSS Bohrstangen Satz SDUC R 07 rechts

HSS boring bars set SDUC R 07 right
Set de barres d'alésage HSS SDUC R 07 droite

Bestell Nr. Order no. Référence	Satz beinhaltet Set consist of Set composé
SET.AH.SDUC.R07	AH0810H.SDUC.R07 AH1012K.SDUC.R07 AH1216M.SDUC.R07



101.TX8
 Torx Klemmschrauben
 Torx clamping screw
 Torx



02.TX8
 Torx-Schraubendreher TX8
 Torx screwdriver TX8
 Tournevis Torx TX8

K Vollhartmetall Bohrstangen SCLC L 06 links

Carbide boring bars SCLC L 06 left
Barres d'alésage en carbure SCLC L 06 à gauche

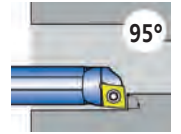

- Schwingungsarme Bohrstangen
 - Mit Innenkühlung
 - Längere Standzeit der Wendeschneidplatten
 - Längsdrehen, sehr gut geeignet für enge Bohrungen
 - Anstellwinkel: 95°
 - Lieferumfang: Ohne Wendeschneidplatten
- *Low-vibration boring bars*
 - *With internal cooling*
 - *Longer durability of inserts*
 - *For longitudinal and plane turning*
 - *Setting angle: 95°*
 - *Delivery: without inserts*
- Barres d'alésage à faibles vibrations
 - Avec arrosage interne
 - Longue durée de vie des plaquettes
 - Tournage longitudinale, très bien adapté pour les trous serrés
 - Angle d'incidence: 95°
 - Livraison: sans plaquettes

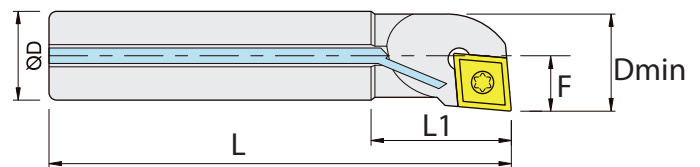

Bestell Nr. Order no. Référence	Wendepatte Inserts Plaquettes	ØD	F	L	L1	Dmin
E08K.SCLC.L06	CCMT / CCGT 0602...	8	5	125	-	10
E10K.SCLC.L06	CCMT / CCGT 0602...	10	6	125	-	12
E12M.SCLC.L06	CCMT / CCGT 0602...	12	7	150	-	14

Vollhartmetall Bohrstangen Satz SCLC L 06 links

Carbide boring bars set SCLC L 06 left
Set de barres d'alésage en carbure SCLC L 06 à gauche

Bestell Nr. Order no. Référence	Satz beinhaltet Set consist of Set composé
SET.E.SCLC.L06	E08K.SCLC.L06 E10K.SCLC.L06 E12M.SCLC.L06



13



101.TX8
Torx Klemmschrauben
Torx clamping screw
Torx



02.TX8
Torx-Schraubendreher TX8
Torx screwdriver TX8
Tournevis Torx TX8

Vollhartmetall Bohrstangen SCLC R 06 rechts



Carbide boring bars SCLC R 06 right Barres d'alésage en carbure SCLC R 06 droite

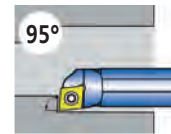

- Schwingungsarme Bohrstangen
- Mit Innenkühlung
- Längere Standzeit der Wendeschneidplatten
- Längsdrehen, sehr gut geeignet für enge Bohrungen
- Anstellwinkel: 95°
- Lieferumfang: Ohne Wendeschneidplatten

- *Low-vibration boring bars*
- *With internal cooling*
- *Longer durability of inserts*
- *For longitudinal and plane turning*
- *Setting angle: 95°*
- *Delivery: without inserts*

- Barres d'alésage à faibles vibrations
- Avec arrosage interne
- Longue durée de vie des plaquettes
- Tournage longitudinale, très bien adapté pour les trous serrés
- Angle d'incidence: 95°
- Livraison: sans plaquettes

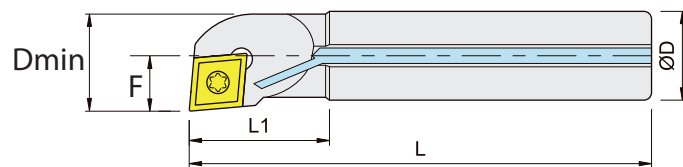

Bestell Nr. Order no. Référence	Wendepatte Inserts Plaquettes	ØD	F	L	L1	Dmin
E08K.SCLC.R06	CCMT / CCGT 0602...	8	5	125	-	10
E10K.SCLC.R06	CCMT / CCGT 0602...	10	6	125	-	12
E12M.SCLC.R06	CCMT / CCGT 0602...	12	7	150	-	14

Vollhartmetall Bohrstangen Satz SCLC R 06 rechts

Carbide boring bars set SCLC R 06 right Set de barres d'alésage en carbure SCLC R 06 droite

Bestell Nr. Order no. Référence	Satz beinhaltet Set consist of Set composé
SET.E.SCLC.R06	E08K.SCLC.R06 E10K.SCLC.R06 E12M.SCLC.R06



101.TX8
Torx Klemmschrauben
Torx clamping screw
Torx



02.TX8
Torx-Schraubendreher TX8
Torx screwdriver TX8
Tournevis Torx TX8

K Vollhartmetall Bohrstangen SDUC L 07 links

Carbide boring bars SDUC L 07 left
Barres d'alésage en carbure SDUC L 07 à gauche

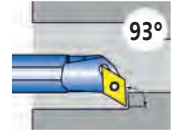

- Schwingungsarme Bohrstangen
 - Mit Innenkühlung
 - Längere Standzeit der Wendeschneidplatten
 - Längsdrehen, sehr gut geeignet für enge Bohrungen
 - Anstellwinkel: 93°
 - Lieferumfang: Ohne Wendeschneidplatten
- *Low-vibration boring bars*
 - *With internal cooling*
 - *Longer durability of inserts*
 - *For longitudinal and plane turning*
 - *Setting angle: 93°*
 - *Delivery: without inserts*
- Barres d'alésage à faibles vibrations
 - Avec arrosage interne
 - Longue durée de vie des plaquettes
 - Tournage longitudinale, très bien adapté pour les trous serrés
 - Angle d'incidence: 93°
 - Livraison: sans plaquettes

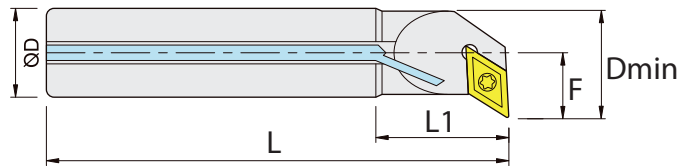

Bestell Nr. Order no. Référence	Wendepatte Inserts Plaquettes	ØD	F	F1	L	L1	Dmin
E10K.SDUC.L07	DCMT-DCGT 0702..	10	7	-	125	-	12
E12M.SDUC.L07	DCMT-DCGT 0702..	12	9	-	150	-	15

Vollhartmetall Bohrstangen Satz SDUC L 07 links

Carbide boring bars set SDUC L 07 left
Set de barres d'alésage en carbure SDUC L 07 à gauche



Bestell Nr. Order no. Référence	Satz beinhaltet Set consist of Set composé
SET.E.SDUC.L07	E10K.SDUC.L07 E12M.SDUC.L07



101.TX8
 Torx Klemmschrauben
 Torx clamping screw
 Torx



02.TX8
 Torx-Schraubendreher TX8
 Torx screwdriver TX8
 Tournevis Torx TX8

Vollhartmetall Bohrstangen SDUC R 07 rechts



Carbide boring bars SDUC R 07 right Barres d'alésage en carbure SDUC R 07 droite

- Schwingungsarme Bohrstangen
- Mit Innenkühlung
- Längere Standzeit der Wendeschneidplatten
- Längsdrehen, sehr gut geeignet für enge Bohrungen
- Anstellwinkel: 93°
- Lieferumfang: Ohne Wendeschneidplatten

- *Low-vibration boring bars*
- *With internal cooling*
- *Longer durability of inserts*
- *For longitudinal and plane turning*
- *Setting angle: 93°*
- *Delivery: without inserts*

- Barres d'alésage à faibles vibrations
- Avec arrosage interne
- Longue durée de vie des plaquettes
- Tournage longitudinale, très bien adapté pour les trous serrés
- Angle d'incidence: 93°
- Livraison: sans plaquettes

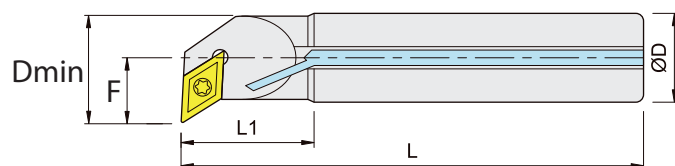
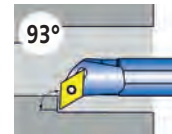

Bestell Nr. Order no. Référence	Wendepatte Inserts Plaquettes	ØD	F	F1	L	L1	Dmin
E10K.SDUC.R07	DCMT-DCGT 0702..	10	7	-	125	-	12
E12M.SDUC.R07	DCMT-DCGT 0702..	12	9	-	150	-	15

Vollhartmetall Bohrstangen Satz SDUC R 07 rechts

Carbide boring bars set SDUC R 07 right Set de barres d'alésage en carbure SDUC R 07 droite

Bestell Nr. Order no. Référence	Satz beinhaltet Set consist of Set composé
SET.E.SDUC.R07	E10K.SDUC.R07 E12M.SDUC.R07



101.TX8
Torx Klemmschrauben
Torx clamping screw
Torx



02.TX8
Torx-Schraubendreher TX8
Torx screwdriver TX8
Tournevis Torx TX8



Wendeschneidplatten CCMT060204

Inserts CCMT060204
Plaquettes CCMT060204

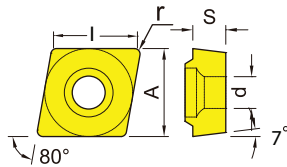

Wendeschneidplatten CCMT060204 für die allgemeine Stahlbearbeitung
Inserts CCMT060204 for general steel processing
Plaquettes CCMT060204 pour l'usinage général d'acier

Bestell Nr. Order no. Référence	Abmessung Size Dimension	l	A	S	d	r
CCMT060.CTC	CCMT060204 CTC1125	6,4	6,35	2,38	2,8	0,4

VC=100-160
f= 0.05-0.25
ap= 0.05-2.5mm

Wendeschneidplatten DCMT070204

Inserts DCMT070204
Plaquettes DCMT070204

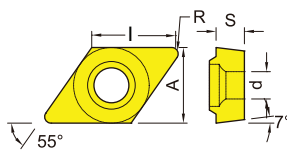

Wendeschneidplatten DCMT070204 für die allgemeine Stahlbearbeitung
Inserts DCMT070204 for general steel processing
Plaquettes DCMT070204 pour l'usinage général d'acier

Bestell Nr. Order no. Référence	Abmessung Size Dimension	l	A	s	d	r
DCMT.070204	DCMT070204	7,75	6,35	2,38	2,8	0,4

VC= 100-160
f= 0.05-0.2
ap=0.05-2mm

13



101.TX8
Torx Klemmschrauben
Torx clamping screw
Torx



02.TX8
Torx-Schraubendreher TX8
Torx screwdriver TX8
Tournevis Torx TX8

KEMMLER OEM

Laserbeschriftung der Werkzeuge

Laser engraving of toolholders

Marquage de porte-outils avec laser



Laserbeschriftung von Werkzeugaufnahmen

Durch unsere Laserbeschriftungsanlagen können wir Ihnen individuelle, kostengünstige Laserbeschriftung der Werkzeuge anbieten. Die dauerhafte Beschriftung kann mit Ihrem Firmennamen, Firmenlogo oder mit sonstigen Sonderzeichen erfolgen. Ebenfalls können die Etiketten auf den Verpackungen nach Ihren Vorgaben gestaltet werden.

Laser engraving of toolholders

With our newly acquired laser engravers we can offer you individual and cost-effective engraving of tools. The permanent engraving can include your company's name, logo or any other special description. Also the labels on the packaging can be designed according to your specifications.

Marquage laser de porte-outils

A l'aide de notre dispositif de marquage avec laser on peut mettre sur vos porte-outils telles données individuelles que par exemple le nom ou le logo de votre société pour le prix raisonnable. En outre selon vos besoins notre équipe peut rajouter des étiquettes sur les emballages avec l'information souhaitée.



TECHNISCHE DATEN
TECHNICAL DATA
DONNÉES TECHNIQUES

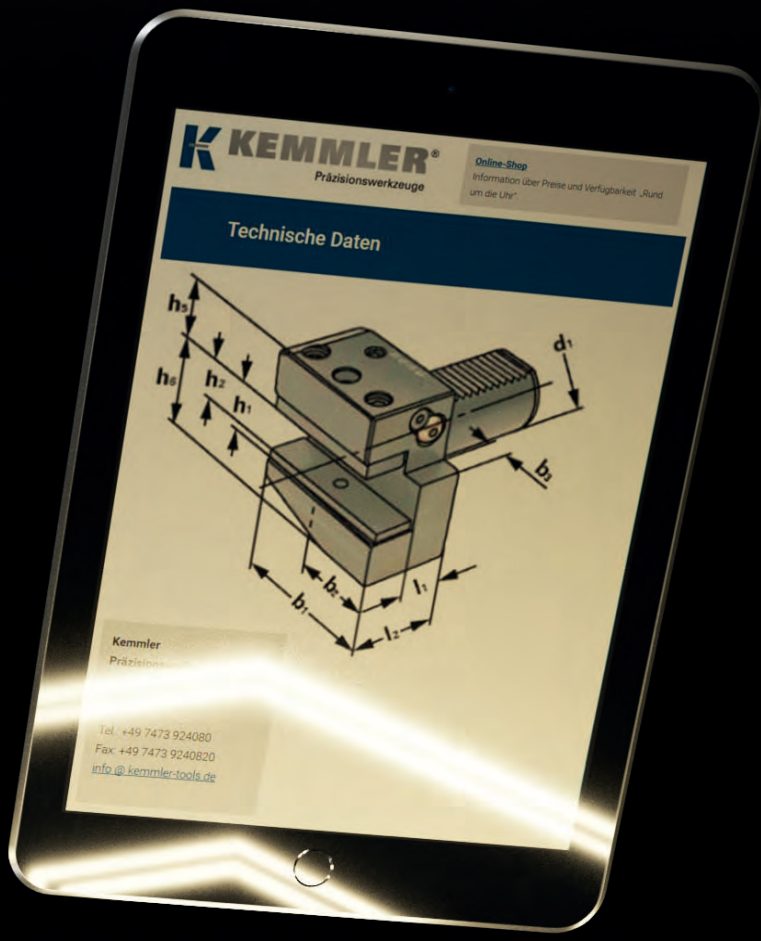

KEMMLER
Präzisionswerkzeuge

Online-Shop
Information über Preise und Verfügbarkeit „Rund um die Uhr“

Technische Daten

Kemmler
Präzisionswerkzeuge
Tel. +49 7473 924080
Fax +49 7473 9240820
info@kemmler-tools.de

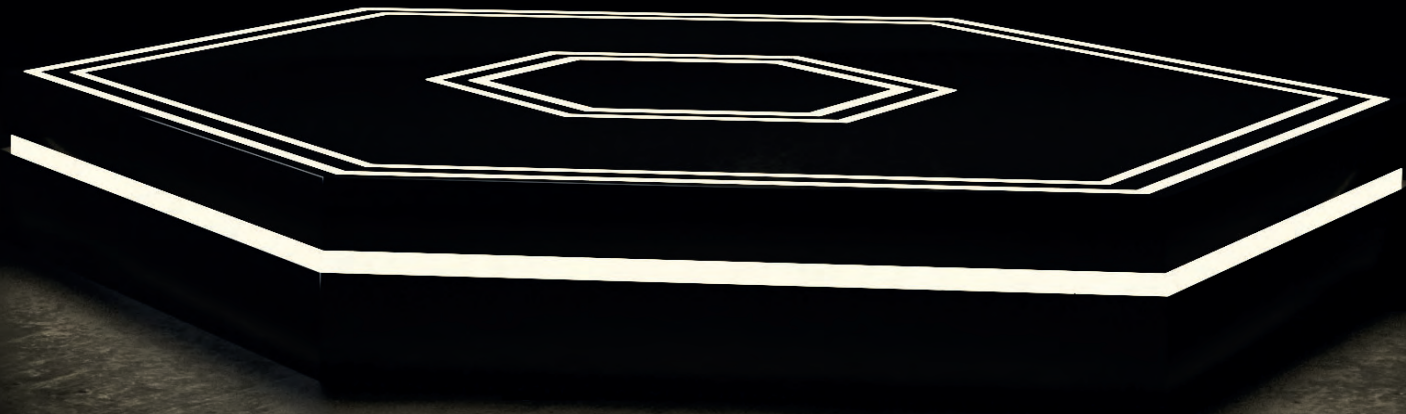



Steilkegel-Aufnahmen _____	14.05	
Anzugsbolzen _____	14.06	
HSK (Hohlschaftkegel) _____	14.07	
Übersicht HSK-Schäfte _____	14.09	
HSK-Kühlmittelübergabeeinheiten _____	14.10	
Unwuchteinflüsse auf Maschinenspindeln, Werkzeugaufnahmen und Werkzeuge _____	14.11	
Hydro-Dehnspannfutter _____	14.13	
Bedien- und Gebrauchsanleitung für Hydro-Dehnspannfutter _____	14.14	
Drehmoment zum Spannen von Weldon-Fräsern _____	14.15	
Bedien- und Gebrauchsanleitung für CNC-Bohrfutter _____	14.16	
Montageanleitung für Spannzangen DIN 6499 _____	14.17	
Montageanleitung für Dichtscheiben _____	14.18	
Gewindeschneidschnellwechselfutter _____	14.19	
Technische Hinweise für Gewindeschneidschnellwechselfutter _____	14.20	
Gewindebohrer-Schaftmaße _____	14.21	
Werkzeugzuordnung für Scheibenrevolver _____	14.22	
Präzisions-Spannzangenfutter System KPS _____	14.23	
Hochleistungs-Kraftspannfutter System HKS _____	14.25	
Laserbeschriftung der Werkzeuge _____	14.26	
Der Kemmler-Nummernschlüssel _____	14.27	
Index _____	14.28	
Table de matières _____	14.52	



Die Maschinenspindeln bei manuellen oder CNC-Maschinen sind mit präzise geschliffenen Innenkegeln versehen, in die die entsprechenden Werkzeugaufnahmen aufgenommen werden. Die Werkzeugaufnahmen werden mit einem Anzugsbolzen oder Gewindestange in die Maschinenspindel eingezogen. Bei CNC-Maschinen erfolgt der Werkzeugeinzug automatisch über einen Anzugsbolzen.

Ein Werkzeughalter besteht aus fünf Grund-Komponenten:

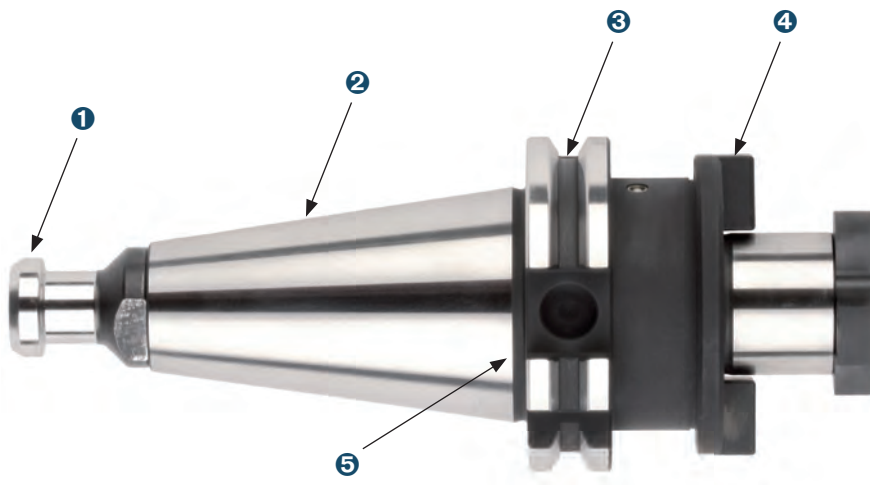

- ❶ Anzugsbolzen
- ❷ Kegelschaft
- ❸ Greiferrille: umlaufende V-Nut
- ❹ Adapter - Werkzeugaufnahme
- ❺ Mitnahme-Nut

Kegelschaft

Der Standard definiert sechs grundlegende Kegelschaft-Größen SK 30, SK 35, SK 40, SK 45, SK 50 und SK 60.

Der passende Kegelschaft für den Maschinentyp

- SK 60 Sehr große Maschinen
- SK 50 Mittlere Maschinen
- SK 40 Kleine Maschinen
- SK 30 Sehr kleine Maschinen

Kühlmitteleinlass Form AD/B

Aufnahmen Form AD/B haben Innenkühlung. Bei Form B (Kühlmitteleinlass durch den Bund) müssen die beiden Gewindestifte entfernt und ein nicht durchbohrter Anzugsbolzen eingesetzt werden. Bei Form AD (zentrale Kühlmitteleinlass) müssen die beiden Gewindestifte im Bund verbleiben und ein Anzugsbolzen mit Bohrung eingesetzt werden.

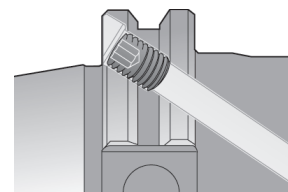

Der Anzugsbolzen erlaubt es dem Spanngreifer der Spindel den Werkzeughalter fest in die Spindel zu ziehen und ihn automatisch auszuwerfen.

Anzugsbolzen gibt es in verschiedenen Ausführungen und Größen. Sie sind nicht untereinander austauschbar.

Nur die Anzugsbolzen verwenden, die vom Maschinenwerkzeughersteller spezifiziert wurden.

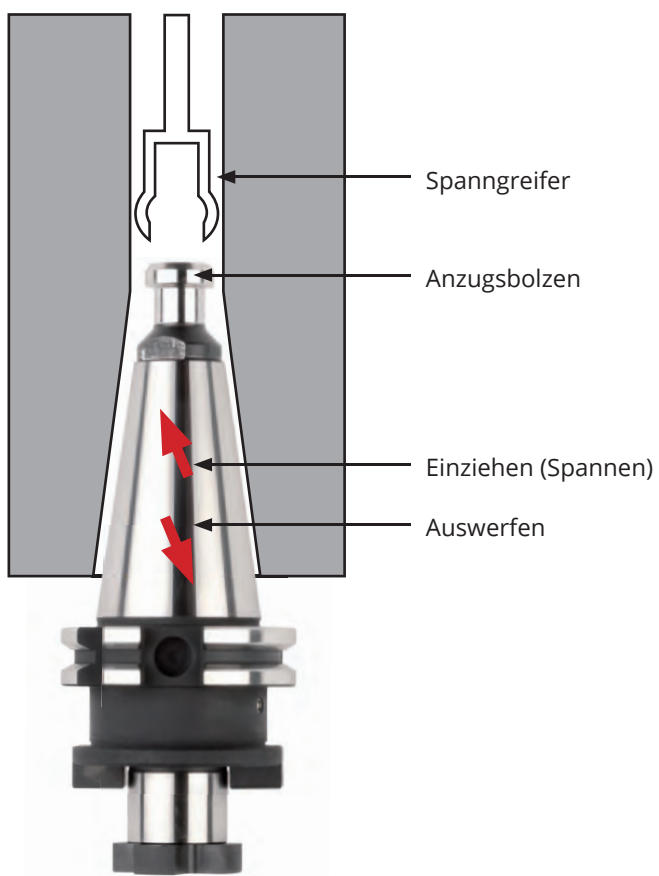

Empfohlenes Anzugsmoment für Montage der Anzugsbolzen:

SK / BT / ISO 30 20 Nm

SK / BT / ISO 40 50 Nm

SK / BT / ISO 50 100 Nm





HSK-Werkzeughalter DIN 69893

Der Hohlschaftkegel (HSK) hat sich seit der Normung als Schnittstelle zwischen Maschine und Werkzeug durchgesetzt.

HSK bietet folgende Vorteile:

- Hohe statische und dynamische Steifigkeit
- Hohe Drehmomentübertragung und definierte radiale Positionierung
- Hohe Wechsel- und Wiederholgenauigkeit
- Hochgeschwindigkeitstauglichkeit
- Kurze Wechselzeiten
- Codierung bzw. Identifizierung
- Kühlmittelzufuhr

Wuchtempfehlung und Grenzdrehzahlen

Kemmler HSK-Aufnahmen sind grundsätzlich vorgewuchtet auf G 6,3 15.000 min⁻¹.

Auf Kundenwunsch ist ein feinwuchten auf höhere Wuchtgüten möglich.

Da die Drehzahl letztendlich den größten Einfluss hat, und auch von der Schnittstelle Spindel bzw. Spindellagerung Grenzen vorliegen, wurden im Rahmen der HSK-Normung folgende Grenzdrehzahlen für die HSK-Schnittstellen als Richtwerte empfohlen:

HSK-A/C 32 bis 30.000 min⁻¹

HSK-A/C 40 bis 30.000 min⁻¹

HSK-A/C 50 bis 30.000 min⁻¹

HSK-A/C 63 bis 25.000 min⁻¹

HSK-A/C 80 bis 20.000 min⁻¹

HSK-A/C 100 bis 16.000 min⁻¹

Abhängig vom Werkzeug kann es bei diesen maximalen Drehzahlen notwendig sein, die Werkzeugaufnahme und das Werkzeug gemeinsam zu wuchten. Klare Grenzwerte können nur unter Berücksichtigung der Maschinen- oder Spindelausführung und bei definierten Werkzeugen mit Auskräglängen bestimmt werden.

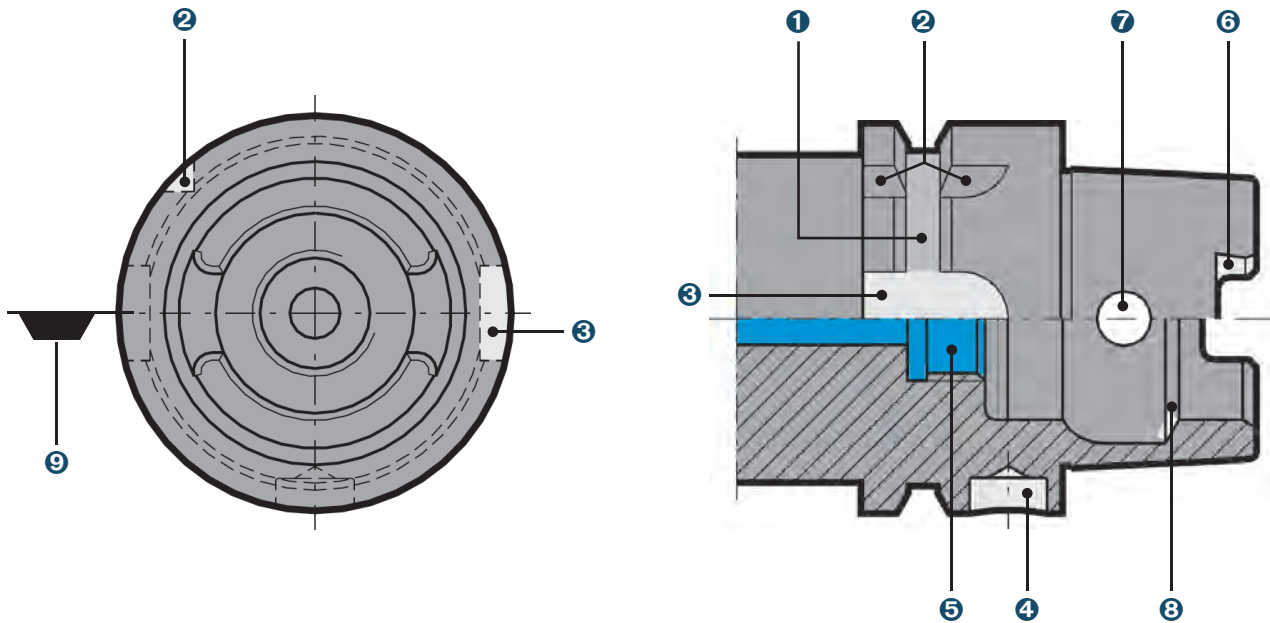

Begriffserklärung an HSK-A-Werkzeugaufnahmen

- ❶ Greiferrille: umlaufende V-Nut
- ❷ Positionskerbe quer zur Greiferrille (dient zur Indexierung)
- ❸ Mitnehmernut am Bund: Zur Indexierung oder zur Aufnahme in einem Werkzeugmagazin oder Greifer. Bei HSK-B/D gleichzeitig zur formschlüssigen Drehmomentübertragung zur Spindel.
- ❹ Codierbohrung: zur Aufnahme eines Datenträgers (Codierchip) im Bund
- ❺ Anschlussgewinde für Kühlmittelübergabeeinheit: zur Aufnahme des Kühlmittelrohrs
- ❻ Mitnehmernut am Kegelschaft: formschlüssige Drehmoment-Kegelschaft Übertragung zur Spindel
- ❼ radiale Zugriffsbohrung im Kegelschaft: zur Betätigung manueller Spannsysteme
- ❽ Spannschulter: Ringfläche, an der das Werkzeug eingezogen wird
- ❾ Lage der Werkzeugschneide bei einschneidigen Werkzeugen



DIN 69063-1 (ISO 12164-1) Form A

Standard-Typ für Bearbeitungszentren und Fräsmaschinen. Hohlschaftkegel für automatischen Werkzeugwechsel mit Greif- und Indexiernut. Manuelle Betätigung durch Zugriffsbohrung im Kegel möglich. Aufnahmebohrung für Datenträger DIN STD 69873 im Flansch. Das Drehmoment wird kraft- und formschlüssig übertragen.

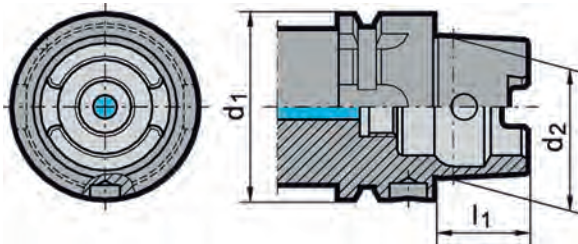

DIN 69063-2 (ISO 12164-1) Form B

Für Bearbeitungszentren, Fräs- und Drehmaschinen. Mit vergrößerter Flanschgröße für stabile Bearbeitung. Für automatischen Werkzeugwechsel. Kühlmittelversorgung durch den Flansch. Aufnahme für Datenträger DIN STD 69873 im Flansch.

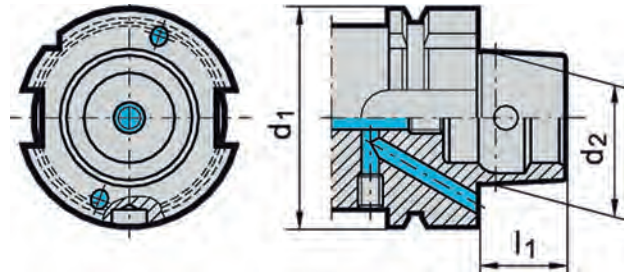

DIN 69063-1 (ISO 12164-1) Form C

Für Transferstraßen, spezielle Maschinen und modulare Werkzeugsysteme. Hohlschaftkegel für manuellen Werkzeugwechsel. Betätigung durch Zugriffsbohrung im Kegel. Da alle Form A Halterungen mit Seitenlöchern für manuellen Werkzeugwechsel ausgestattet sind, können sie auch als Form C Halterungen verwendet werden. Das Drehmoment wird kraft- und formschlüssig übertragen.

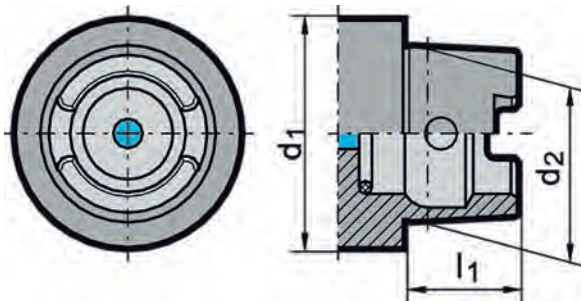

DIN 69063-2 (ISO 12164-2) Form D

Für spezielle Maschinen. Mit vergrößerter Flanschgröße für stabile Bearbeitung. Für manuellen Werkzeugwechsel. Kühlmittelversorgung durch den Flansch.

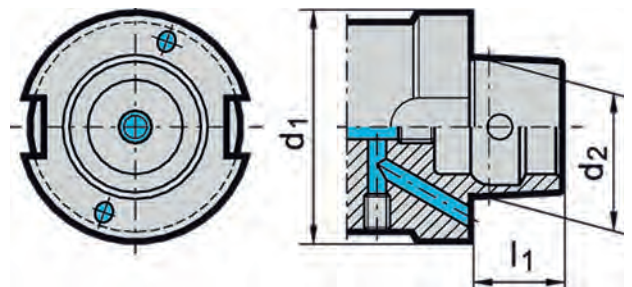

DIN 69063-5 Form E

Für Hochgeschwindigkeits-Bearbeitung. Hohlschaftkegel für automatischen Werkzeugwechsel. Das Drehmoment wird kraftschlüssig übertragen. Ausführung mit Zugriffsbohrung nach DIN 69893-1 nach Vereinbarung.

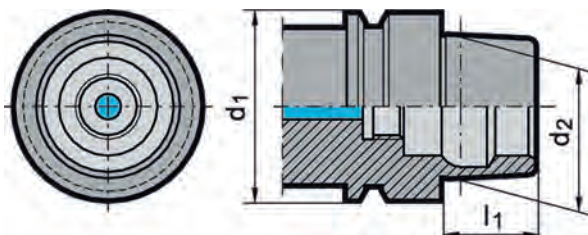

DIN 69063-6 Form F

Für Hochgeschwindigkeits-Bearbeitungen, hauptsächlich in der Holzverarbeitenden Industrie. Hohlschaftkegel für automatischen Werkzeugwechsel. Mit vergrößerter Flanschgröße für stabile Bearbeitung. Das Drehmoment wird kraftschlüssig übertragen. Ausführung mit Zugriffsbohrung nach DIN 69893-1 nach Vereinbarung.

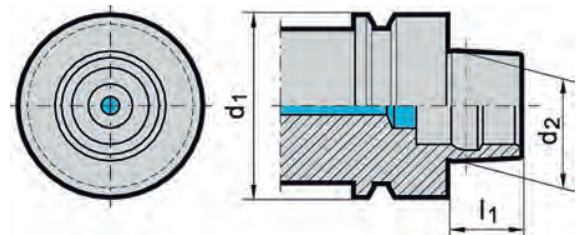

Bei Bearbeitung mit Innenkühlung müssen HSK-Aufnahmen Form A mit einem Kühlmittelrohr bestückt werden.

Werden Aufnahmen mit Innenkühlung ohne Kühlmittelübergabeinheiten eingesetzt kann dies zur Beschädigung der Spindel führen.

Für DIN 69893 Form C, -E und -F sind keine Kühlmittelrohre erforderlich.
Die zentrale Kühlmittelzufuhr bzw. Abdichtung erfolgt durch eine Spanneinheit.

Der Einbau des Kühlmittelrohres wird idealerweise in vertikaler Richtung – von unten nach oben – vorgenommen. Hierdurch soll verhindert werden, dass der Dichtring beim Einschrauben verrutscht, bzw. verdrückt wird und somit seine Abdichtfunktion verliert.

Das Kühlmittelrohr ist nach dem Einbau, gemäß DIN, minimal beweglich ($\pm 1^\circ$).

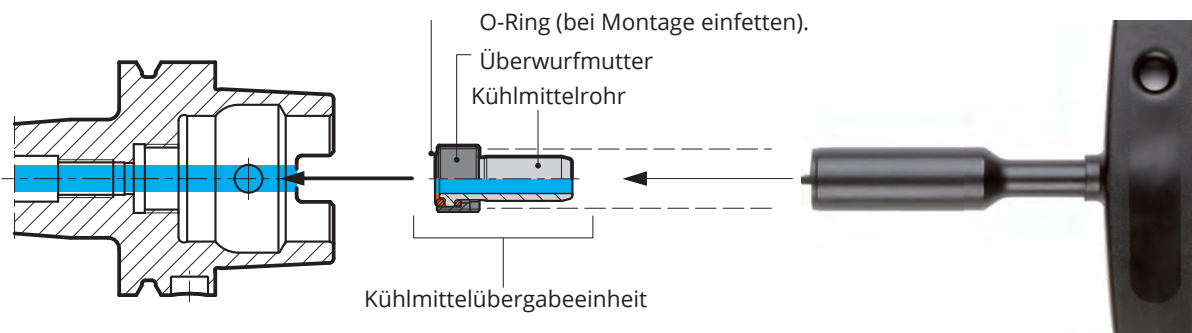

Montage

1. Die HSK-Aufnahme muss sauber und frei von Spänen und Beschädigungen sein.
2. Die O-Ringe vor Montage einfetten.
3. Den Kühlmittelübergabe-Satz vollständig (Kühlmittelrohr, Überwurfmutter und 2 O-Ringe) mit Hilfe des Steckschlüssels zentrisch in den HSK einführen.
4. Den Kühlmittelübergabe-Satz/die Kühlmittelübergabe-Einheit einschrauben und fest anziehen. (Drehmoment s. Tabelle rechts)
5. Das Kühlmittelrohr auf radiale Beweglichkeit prüfen.

Drehmoment

für HSK	Mt (Nm)
32	7
40	11
50	15
63	20
80	25
100	30

K Unwuchteinflüsse auf Maschinenspindeln, Werkzeugaufnahmen und Werkzeuge



Die Unwucht

Eine Unwucht erzeugt bei der sich drehenden Spindel eine Fliehkraft, die die Lauf-
ruhe des Werkzeugs stört. Diese Unwucht hat Einfluss auf den Arbeitsprozess und die
Lebensdauer des Spindellagers. Die Fliehkraft F wächst linear mit der Unwucht U und
quadratisch mit der Drehzahl nach untenstehender Formel.

Auswuchten

Um unerwünschte Fliehkkräfte auszugleichen, muss die symmetrische Massenver-
teilung wiederhergestellt werden, mit dem Ziel, dass auf die Spindellagerung keine
Fliehkkräfte wirken. Bei Werkzeugaufnahmen sind Ausgleichsbohrungen oder -flächen
üblich. Dadurch tendiert die Summe aller auf die Achse wirkenden Fliehkkräfte gegen
Null
(s. DIN ISO 1940).

Schwerpunktverlagerung

Durch die Unwucht einer Welle wird deren Schwerpunkt aus der Drehachse um
einen Abstand in Richtung der Unwucht verlagert. Dieser Schwerpunktabstand wird
auch Restexzentrizität e oder Schwerpunktverlagerung genannt. Je größer die
Wuchtkörpermasse m ist, desto größer kann die zulässige Restunwucht U sein.

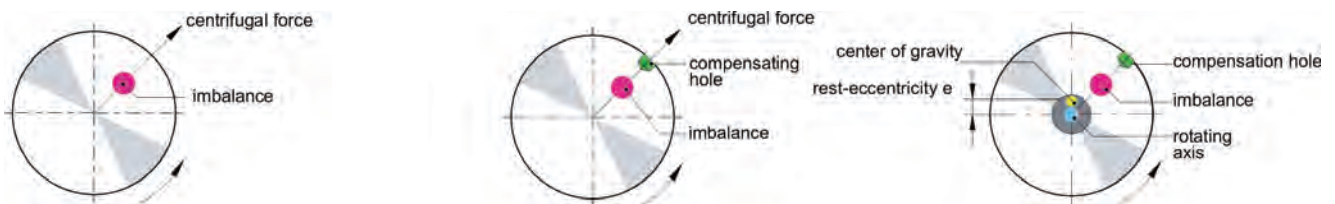

Unwuchtberechnung

Die Unwucht ist ein Maß, das angibt, wieviel unsymmetrisch verteilte Masse in radialer
Richtung von der Drehachse entfernt ist. Die Unwucht wird in gmm angegeben.
Das Abstandmaß e sagt aus, wie weit der Schwerpunkt eines Teils von der Drehachse
entfernt ist.

Die Unwucht ergibt sich aus:

$$U = m \times r$$

U = Unwucht in gmm

e = Schwerpunktabstand in μm

m = Masse in kg

Wuchtgrenzen

Entsprechend DIN ISO 1940 wird die Auswuchtgüte mit G sowie den Einheiten gmm/kg bzw. μm bezeichnet und ist drehzahlbezogen. Bei einer Drehzahl von 15.000 U/min und einem Gewicht von 1 kg entspricht G 6,3 einem zulässigen Mittenversatz zwischen Rotationsachse und Schwerpunktachse der Spindel von $4 \mu\text{m}$. Bei doppelter Drehzahl von 30.000 U/min wären es $2 \mu\text{m}$. Wiegt der Werkzeughalter nur noch die Hälfte, also 0,5 kg, halbiert sich auch die zulässige Auswuchtteranz. Ziel des Auswuchtens muss es sein, einen Kompromiss zwischen dem technisch Machbaren und dem wirtschaftlich Sinnvollen zu finden. Da die radiale Wechselgenauigkeit bei einer fabrikneuen HSK-Aufnahme bereits 2 bis $3 \mu\text{m}$ und bei einer SK-Aufnahme bereits 5 bis $10 \mu\text{m}$ betragen kann, bedeutet das bereits eine Qualitätsgrenze von G 2,5 bzw. G 6,3 bei 10.000 U/min.

Die nachstehende Grafik zeigt die Gütestufen nach DIN ISO 1940-1, also die zulässigen, auf die Wuchtkörpermasse bezogene Restunwuchten für verschiedene Auswuchtgüten G in Abhängigkeit von der höchsten Betriebsdrehzahl.

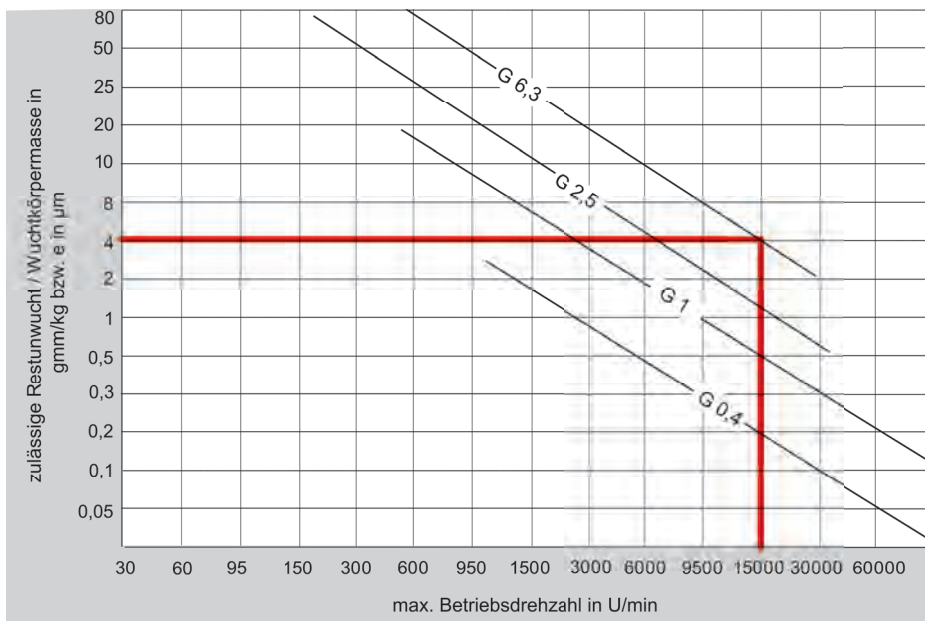

KEMMLER Werkzeugaufnahmen werden auf G 6,3 / 15.000 U/min gewuchtet.

Feingewuchtet durch Bohrungen in der Greiferrille



Vorgewuchtet durch Wuchtbohrungen am Bund

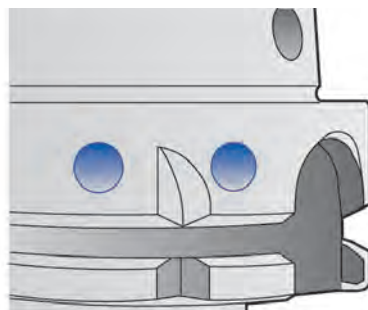

Vorgewuchtet durch Wuchtfläche am Werkzeugkörper





Moderne Zerspanungsprozesse stellen besondere Anforderungen an die Werkzeugaufnahme. Hydraulik-Dehnspannfutter bieten deshalb guten Halt, verbunden mit einem exakten Rundlauf. Zudem ermöglichen sie einen leichten und schnellen Werkzeugwechsel.

Durch Drehen der Druckschraube entsteht in der Druckkammer ein ausreichend hoher Druck, der zur elastischen Verformung der Dehnspannhülse führt, wodurch das Werkzeug kraftvoll gespannt wird – und das bei exaktem Rundlauf. Dies sorgt für einen sicheren und kraftschlüssigen Sitz. Werden Reduzierbuchsen, die unterschiedliche Werkzeugdurchmesser aufnehmen können, benutzt, dann lässt sich der Werkzeugeinsatz beliebig erweitern.

Vorteile

- Präzise Werkzeugspannung bei maximal 3 µm Rundlauffehler
- Übertragung hoher Drehmomente durch optimiertes Dehnhülensystem (hohe Spannung)
- Hochgeschwindigkeitstauglich (keine Fliehkräfte durch Spannsegmente)
- Exakter Rundlauf, dadurch hervorragende Oberflächengüte und Maßhaltigkeit am Werkstück
- Rascher Werkzeugwechsel mittels leicht betätigbarer Spannschraube
- Optimale Werkzeugstandzeiten
- Vibrationsdämpfende Wirkung durch Hydro-Polster

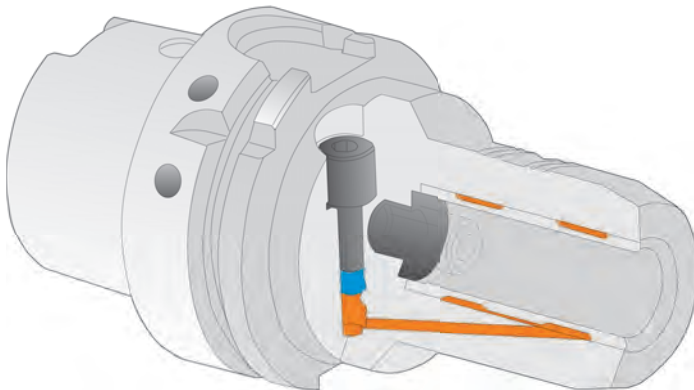

Spannen genormter Werkzeugschäfte nach DIN 6535 in Hydro-Dehnspannfutter

Werkzeugschäfte für Direkteinspannung
Rundlauf $\leq 0,003$ mm

Form HA $\varnothing 6 \dots 32$ mm

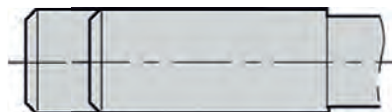

Form HB $\varnothing 6 \dots 20$ mm

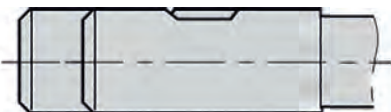

Werkzeugschäfte für Spannung mit Hilfe von Reduzierbuchsen
Rundlauf $\leq 0,005$ mm

Form HB $\varnothing 25 \dots 32$ mm



Form HE $\varnothing 6 \dots 32$ mm





Um eine fehlerfreie Funktion der Hydro-Dehnspannfutter zu gewährleisten, beachten Sie bitte folgende Anweisungen:

Verwendung von Zylinderschaftwerkzeugen nach DIN 1835 und DIN 6535 Form (HA) und B (HB) bis Ø 20 mm Spannschaft mit Herstelltoleranz h_6 , feingeschliffen $Ra_{min} = 0,3$.

Schäfte nach DIN 6535 Form HE (Whistle Notch) sind nur in Verbindung mit Reduzierstücken einsetzbar. Alle Hydro-Dehnspannfutter sind bis G 6,3 15.000 min^{-1} ab Werk vorgewuchtet.

Spannen und Lösen eines Werkzeuges

1. Reinigen der Futteraufnahmebohrung und des Werkzeugschaftes von Fett und Schmutz. Werkzeugschaft bis zum Anschlag einführen. Mindestspannlänge und Verstellweg sind unbedingt einzuhalten.
2. Mit Sechskantquergrieffschlüssel im Uhrzeigersinn die Spannschraube bis zum Anschlag drehen. Das Werkzeug ist gespannt. Wegen Bruchgefahr der Dehnspannhülse keine Leerspannungen vornehmen.
3. Zum Lösen des Werkzeuges Spannschraube ca. 5 bis 6 Umdrehungen zurückdrehen und das Werkzeug entnehmen.

Hinweis: Niemals ohne eingespanntes Werkzeug spannen!

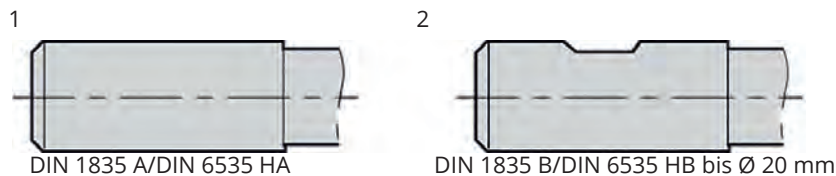

Reinigung

Auf Sauberkeit von Aufnahmebohrung und Werkzeugschaft achten.

Temperatur

Optimaler Temperaturbereich zwischen 10–50 °C. Bei Temperaturen über 80 °C nicht einsetzen.

Lagerung

Hydro-Dehnspannfutter entspannt, gereinigt und leicht eingeölt lagern.

Spannschäfte

Nur Werkzeugschäfte der DIN 1835 Form A und Form B (bis 20 mm) spannen.

Drehmoment

Spann-Ø mm	Mt (Nm)	Toleranz des Schaftwerkzeuges
6	10	h_6
8	10	h_6
10	10	h_6
12	10	h_6
14	10	h_6
16	10	h_6
18	10	h_6
20	10	h_6
25	10	h_6
32	10	h_6





Höchste Rundlaufgenauigkeiten mit definierten Drehmomenten bei Weldonschäften:



Drehmomente für DIN 1835

Bohrung	Schraube		Drehmoment
Ø 6 mm	M 6	SW 3	10 Nm
Ø 8 mm	M 8	SW 4	10 Nm
Ø 10 mm	M 10	SW 5	16 Nm
Ø 12 mm	M 12	SW 6	28 Nm
Ø 14 mm	M 12	SW 6	28 Nm
Ø 16 mm	M 14	SW 6	42 Nm
Ø 18 mm	M 14	SW 6	42 Nm
Ø 20 mm	M 16	SW 8	50 Nm
Ø 25 mm	M 18 × 2	SW 10	60 Nm
Ø 32 mm	M 20 × 2	SW 10	72 Nm
Ø 40 mm	M 20 × 2	SW 10	72 Nm
Ø 50 mm	M 24 × 2	SW 12	90 Nm
Ø 63 mm	M 24 × 2	SW 12	90 Nm

Spannen und Lösen des Werkzeuges

Um eine fehlerfreie Funktion der CNC-Bohrfutter 08 / 13 / 16 zu gewährleisten beachten Sie bitte folgende Anweisungen:

Achtung:

Das Werkzeug darf nur bei stillstehender Spindel oder außerhalb der Maschine gespannt werden.

Das CNC-Bohrfutter (Pos. 1) wird mit einem Sechskantquergriffschlüssel (Pos. 3) seitlich über einen Kegeltrieb gespannt. Drehen Sie den Sechskantschlüssel im Uhrzeigersinn um das Bohrfutter zu spannen, im Gegenuhrzeigersinn um das Bohrfutter zu öffnen.

1. Schritt

Öffnen Sie die Spannbacken des Bohrfutters weit genug um das Schneidwerkzeug (Pos. 2) einzulegen.

2. Schritt

Das Werkzeug (Pos. 2) wird bis zum Anschlag in das CNC-Bohrfutter (Pos. 1) eingeführt. (Bild 1)

3. Schritt

Drehen Sie den Sechskantschlüssel (Pos. 3) mit einem Anzugsmoment von 15 Nm (bei 0,5-8 = 10 Nm) im Uhrzeigersinn, um das Werkzeug ordnungsgemäß zu spannen. (Bild 2)

Achtung:

Keine Verlängerung oder Anzugshilfe verwenden. Bei einem Anzugsmoment größer 15 Nm (bei 0,5-8 = 10 Nm) kann der Kegeltrieb zerstört werden. Hierbei ist das Ritzel die Sollbruchstelle, um größere Beschädigungen am Bohrfutter zu verhindern.

4. Schritt

Überprüfen Sie nach dem Spannvorgang ob das Werkzeug zentrisch gespannt ist.

Achtung:

Keine konischen Schäfte spannen – Unfallgefahr!

5. Schritt

Das CNC-Bohrfutter ist betriebsbereit und kann in die Maschinenspindel eingespannt werden. (Bild 3)

6. Schritt

Zum Lösen des Werkzeuges drehen Sie den Sechskantschlüssel im Gegenuhrzeigersinn und entnehmen das Werkzeug.

Wartung und Reinigung

Die CNC-Bohrfutter 08 / 13 / 16 sind wartungsfrei, sollten aber nach dem Gebrauch mit Druckluft und einem sauberen Lappen gereinigt werden. Die Reinigung mit Lösungsmittel kann Korrosion verursachen. Daher das Bohrfutter vor dem Einlagern mit Öl einsprühen.

Reparatur

Im Reparaturfall bitten wir Sie das CNC-Bohrfutter an uns zurückzusenden. Wir tauschen dann grundsätzlich den kompletten Bohrfutterkopf aus.

Auf diese Weise erhalten Sie schnellstmöglich Ersatz und nur auf diese Weise kann ein ordnungsgemäßes Funktionieren der Bohrfutter und eine Rundlaufabweichung < 0,03 mm gewährleistet werden.



Bild 1



Bild 2



Bild 3



Montage:

Nut der Spannzange in den Exzenterring der Spannmutter einhängen. Spannzange in entgegengesetzte Richtung kippen, bis diese deutlich hörbar einrastet. Werkzeug einsetzen. Spannmutter mit der eingerasteten Spannzange auf das Gewinde des Spannfutters schrauben. Wir empfehlen, die Spannmutter mit einem Drehmomentschlüssel anzuziehen.

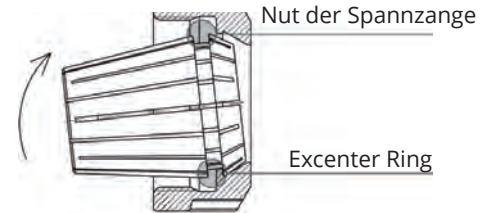

Demontage:

Nach dem Abschrauben vom Spannfutter auf die Frontseite der Spannzange drücken und gleichzeitig die Spannzange durch seitlichen Druck auf den hinteren Teil aus der Einrastung der Mutter herausnehmen.

Eine falsche Handhabung beeinträchtigt den Rundlauf der Spannzange und kann die Spannmutter beschädigen.

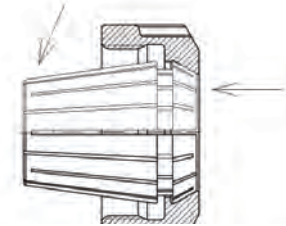

Achtung:

Nur Spannmuttern mit richtig eingerasteter Spannzange montieren!

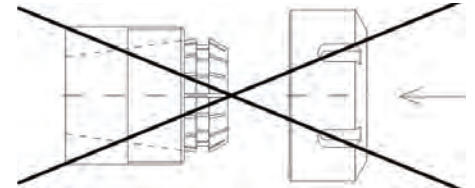

Niemals Schäfte mit Übermaß spannen!

z. B. niemals in eine Zange mit $\varnothing 12-11$ mm einen Schaft mit $\varnothing 12,2$ mm einpressen. Verwenden Sie jeweils die nächst grössere Spannzange (hier 13-12 mm).

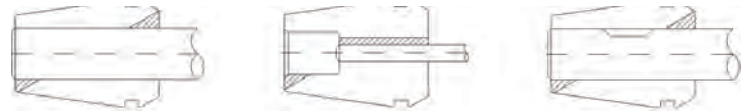

Werkzeugschaft möglichst auf der gesamten Länge der Spannzange spannen (mindestens jedoch 2/3 der Spannzangenlänge).



Maximales Drehmoment

ER 16	M22 × 1,5	50 Nm
ER 20	M25 × 1,5	75 Nm
ER 25	M32 × 1,5	85 Nm
ER 32	M40 × 1,5	105 Nm
ER 40	M50 × 1,5	150 Nm
ER 11 Mini	M13 × 0,75	18 Nm
ER 16 Mini	M19 × 1	28 Nm

Bitte beachten Sie das angegebene maximale Drehmoment.



Montage:

Die Dichtscheibe mit dem kleineren Durchmesser zuerst von innen in die Spannmutter einführen und den Druck gleichmäßig erhöhen bis die Dichtscheibe einrastet. Die Dichtscheibe muss bündig mit der Vorderseite der Spannmutter sein.

Demontage:

Um die Dichtscheibe zu entfernen, gleichmäßig von außen auf Dichtscheibe drücken bis sie herauspringt.

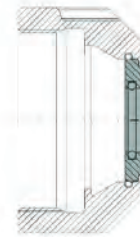
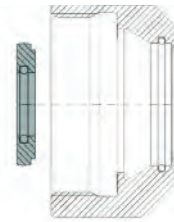

Bezeichnung Designation Désignation	E	EP	EA	EC	ECC	EH	ESP	G	GA	GC
Rundlauf Concentricity Concentricité	≤ 15 µ	≤ 5 µ	≤ 15 µ	≤ 15 µ	≤ 15 µ	≤ 15 µ	≤ 5 µ	≤ 15 µ	≤ 15 µ	≤ 15 µ
Spanndurchmesserüberbrückung Collapse Plage de serrage	0,5-1 mm	0,5-1 mm	h8	h8	h8	h8	h8	h8	h8	h8
Rostfrei Stainless Inoxydable	-	-	-	-	-	-	X	-	-	-
Abdichtung für IK (Innenkühlung) Sealing for IC (inner coolant supply) Avec joint d'étanchéité pour AC	-	-	X	-	-	X	-	-	X	-
Kühlkanalbohrung für IK (Innenkühlung) Jet holes for Inner Coolant Supply Avec canaux d'arrosage au centre	-	-	-	X	X	-	-	-	-	X
Innenvierkant für Gewindebohrer For tapping with internal square drive Pour taraudage avec carré d'entraînement	-	-	-	-	-	-	-	X	X	X



Der Gewindebohrprozess ist eine Kombination aus radialen und axialen Bewegungen. Es ist manchmal notwendig die axiale Bewegung des Werkzeugs einzuschränken.

Wenn die axiale Bewegung unkontrolliert verläuft, könnten die Führungszähne des Gewindebohrers nachschneiden und so ein übergroßes Gewinde erzeugen.

Längenausgleich (Zug) – der Ausgleich ermöglicht es dem Gewindebohrer ohne Einfluss von axialem Vorschub der Maschinenspindel ein Gewinde zu erzeugen.



Längenausgleich (Druck) – der Ausgleich wirkt wie ein Polster und erlaubt es dem Gewindebohrer in das Material einzudringen. Auch dieser Vorgang ist unabhängig vom Maschinenvorschub.



Längenausgleich (Druck/Zug) – der Ausgleich ist dazu gedacht alle externen Kräfte während des Bearbeitungsvorgangs auszugleichen.



Radialer Pendelausgleich – gleicht eine geringe Abweichung der Maschinenspindel-Achse und der Bohrungsachse aus. Dieses sollte möglichst vermieden werden.





Bitte beachten Sie den angegebenen Längenausgleich in mm schon vor dem ersten Gewindeschneiden. Dies vermeidet ein Überschreiten der Werte und somit Futter- und Gewindebohrer-Beschädigungen.



Artikel	Bereich	Einsatz	Längenausgleich in mm auf	
			Druck	Zug
xxx.16.12	M 3 – M14	16.11.xx / 16.01.xx	7	7
xxx.16.20	M 5 – M22	16.12.xx / 16.02.xx	12	12
xxx.16.36	M14 – M36	16.14.xx / 16.03.xx	17,5	17,5



Schaftmaße					
Ø × □	DIN 352	DIN 5157	DIN 371	DIN 374	DIN 376
Ø 2,5 × 2,1 □	M1		M1	M3	M3,5
Ø 2,5 × 2,1 □	M1,1		M1,1	M3,5	
Ø 2,5 × 2,1 □	M1,2		M1,2		
Ø 2,5 × 2,1 □	M1,4		M1,4		
Ø 2,5 × 2,1 □	M1,6		M1,6		
Ø 2,5 × 2,1 □	M1,8		M1,8		
Ø 2,8 × 2,1 □	M2		M2	M4	M4
Ø 2,8 × 2,1 □	M2,2		M2,2		
Ø 2,8 × 2,1 □	M2,5		M2,5		
Ø 3,5 × 2,7 □	M3		M3	M5	M5
Ø 4 × 3 □	M3,5		M3,5		
Ø 4,5 × 3,4 □	M4		M4	M6	M6
Ø 6 × 4,9 □	M5		M5		
Ø 6 × 4,9 □	M6		M6		
Ø 6 × 4,9 □	M8			M8	M8
Ø 7 × 5,5 □	M10	G 1/8"		M10	M10
Ø 8 × 6,2 □			M8		
Ø 9 × 7 □	M12			M12	M12
Ø 10 × 8 □			M10		
Ø 11 × 9 □	M14	G 1/4"		M14	M14
Ø 12 × 9 □	M16	G 3/8"		M16	M16
Ø 14 × 11 □	M18			M18	M18
Ø 16 × 12 □	M20	G 1/2"		M20	M20
Ø 18 × 14,5 □	M22	G 5/8"		M22	M22
Ø 18 × 14,5 □	M24			M24	M24
Ø 20 × 16 □	M27	G 3/4"		M27	M27
Ø 22 × 18 □	M30	G 7/8"		M30	M30
Ø 25 × 20 □	M33	G 1		M33	M33
Ø 28 × 22 □	M36	G 1 1/8"		M36	M36
Ø 32 × 34 □	M39	G 1 1/4"		M39	M39
Ø 32 × 24 □	M42			M42	M42
Ø 36 × 29 □	M45	G 1 3/8"		M45	M45
Ø 36 × 29 □	M48	G 1 1/2"		M48	M48
Ø 36 × 29 □		G 1 3/4"			
Ø 36 × 29 □		G 2"			

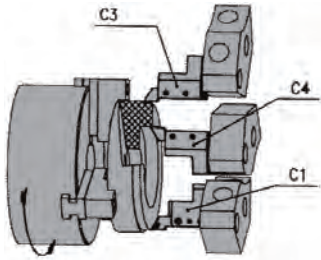

Einsatz von Radial-Werkzeughaltern bei linker Spindeldrehrichtung

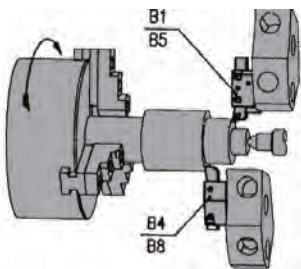

Einsatz von Radial-Werkzeughaltern bei rechter Spindeldrehrichtung

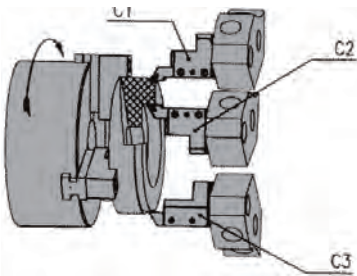

Einsatz von Axial-Werkzeughaltern bei linker Spindeldrehrichtung

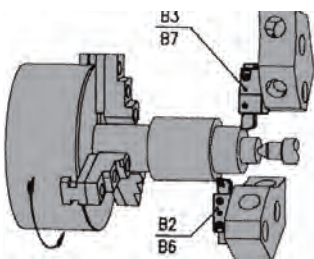

Einsatz von Axial-Werkzeughaltern bei rechter Spindeldrehrichtung



Das Kemmler Präzisions-Spannzangenfutter ist die Alternative zu Hydro-Dehnspannfuttern und Schrumpfaufnahmen.

Hohe Flexibilität durch austauschbare Spannzangen (Präzisions-Spannzangen System KPS verfügbar von Ø 0,5 bis 16 mm).

Hohe Spannkraft und Rundlaufgenauigkeit ergeben eine erstklassige Oberfläche und längere Werkzeugstandzeiten.

Glatte Spannmutter ohne Nuten für Hochgeschwindigkeitsbearbeitung.
Schlanke Ausführung.



Spannschaft:

Zylindrisch DIN 1835-1 Form A/DIN 6535 Form HA, Toleranz h_8 .

Werkzeugschäfte müssen dem nominalen Durchmesser der Spannzangen entsprechen. Spannzangen sind in Stufen von 0,5 mm verfügbar.

Rundlauf:

Max. Rundlauf-Abweichung 5 μm bei $4 \times d$ des eingespannten Werkzeugs.

Neigungswinkel:

Die Spannfläche hat einen Neigungswinkel von 4° , so dass radiale Kräfte während des Spanns nicht auftreten können und keinen Einfluss auf den Rundlauf haben.



Auswuchtung:

Standardmäßig feinausgewuchtet (G 2,5 30.000 min^{-1}).

Hinweis:

Spannzangenfutter System KPS werden standardmäßig ohne Anschlagsschrauben geliefert, da diese bei hohen Drehzahlen nicht zu empfehlen sind.

Spannzangen- größe	Spannbereich mm	Ø Stufen mm	Max. Anzugs- moment	Typ D Zulässige max. Drehzahl*
D16 (KPS 10)	0,5 – 10	0,5	40 Nm	60.000
D24 (KPS 16)	1,0 – 16	0,5	70 Nm	40.000

* Die max. Drehzahl für Aufnahmen dieser Art wird begrenzt durch Größe und Form des Kegelschaftes.



Übertragbares Drehmoment (Nm) auf Werkzeugschaft (statisch gemessen)



Montage der KPS-Spannzangen mit der Montagehilfe

1. Die Spannmutter vom Spannfutter lösen.
2. Die Spannzange in die Montagehilfe einsetzen.
3. Die Spannzange mit der Montagehilfe bis zum Anschlag in die Spannmutter einschieben.
4. Die Montagehilfe ausklinken.
5. Die Spannmutter mit der Spannzange auf das Spannfutter montieren.



Demontage

Setzen Sie die Spannzange zusammen mit der Spannmutter in die Montagehilfe ein, um die Spannzange zusammenzudrücken. Anschließend die Spannmutter entfernen.



KPS-Spannzange



KPS-Montagehilfe*



KPS-Spannmutter*



KPS-Spannschlüssel



Die Hochleistungs Kemmler Präzisions-Spannzangenfutter sind für nahezu alle Anwendungen geeignet. Insbesondere in der Schwerzerspannung garantieren wir unübertroffen hohen Spannkkräfte und hohe Prozesssicherheit. HKS Kraftspannfutter führen durch die Steifigkeit des Futter, seine Rundlaufgenauigkeit und das Spannen bereits bei 3mm ab Futter Nase zu hervorragendem Oberflächenfinish und günstigen Werkzeugstandzeiten. Alle HKS Kraftspannfutter gewähren eine maximale Abweichung der Rundlaufgenauigkeit von 3 µm bei 3 x D.

Verwendung:

- Schwerzerspannung
- Schlichtfräsen
- Hartfräsen
- Bohren, Reiben
- Gewindefräsen

Rundlauf:

Max. Rundlauf-Abweichung 3 µm bei 3x d des eingespannten Werkzeugs.

Auswuchtung:

Standardmäßig feinausgewuchtet (G 6,3 15.000 min⁻¹).

Spannschaft:

Alle marktüblichen Werkzeugschäfte mit oder ohne Weldonschaft können direkt oder mit Spannhülse gespannt werden.

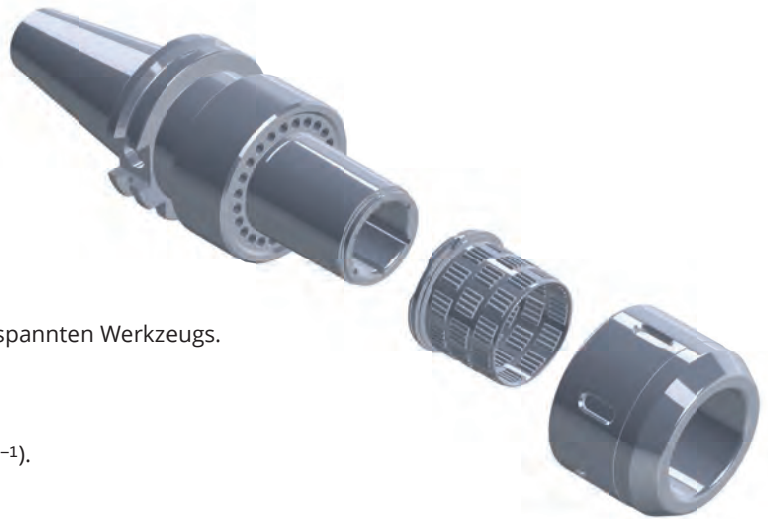

Größe	20mm	25mm	32mm
Anzugsmoment	50-70 Nm	80-100 Nm	80-100 Nm
Spannkraft	780 Nm	2000 Nm	2000 Nm





RELEASE THE BEAST



KEMMLER

K KEMMLER®
Präzisionswerkzeuge



Beispiel:

40 3 . 02 . 20 . 1

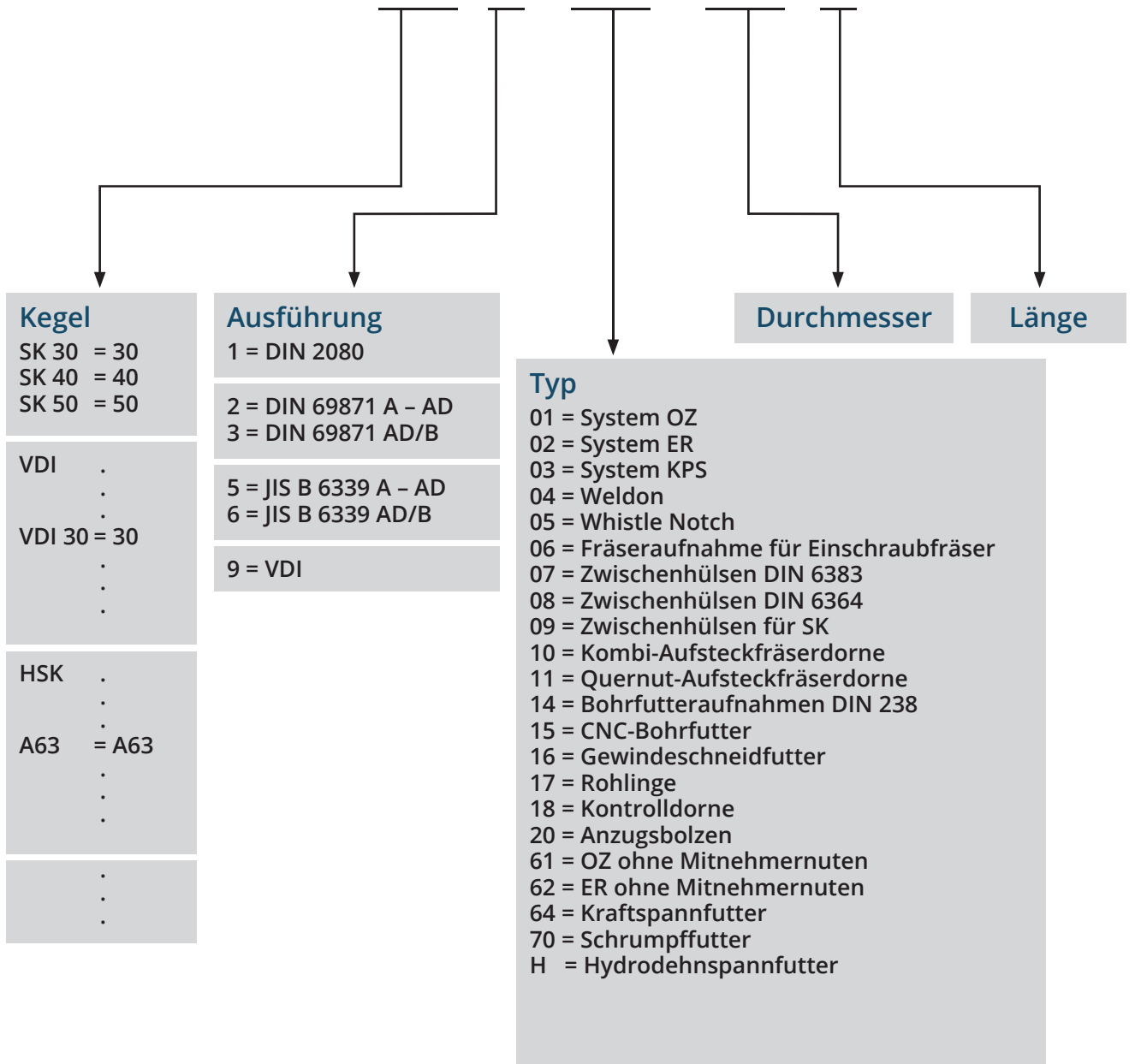

Steep taper _____	14.29	
Pull studs _____	14.30	
HSK (hollow taper shanks) _____	14.31	
Overview HSK (hollow taper shanks) _____	14.33	
HSK coolant tubes _____	14.34	
Effects of imbalance on machine spindles, toolholders and tools _____	14.35	
Hydraulic expansion chucks _____	14.37	
Operating and user instructions for hydraulic expansion chucks _____	14.38	
Torques for clamping end-mills _____	14.39	
Operating and user instructions for CNC-drill chucks _____	14.40	
Mounting instructions for ER-collets per DIN STD 6499 _____	14.41	
Mounting instructions for sealing discs _____	14.42	
Quick-change tapping chucks _____	14.43	
Instructions for tapping chucks _____	14.44	
Screw taps-shaft size _____	14.45	
Tool assignment for disc turrets _____	14.46	
High precision collet chucks KPS-system _____	14.47	
High-performance milling chucks HKS-system _____	14.49	
Laser engraving of toolholders _____	14.50	
The Kemmler-numerical code _____	14.51	

K Steep Taper



Large manual machines and CNC machines use toolholders that have been precisely ground with a male taper that mates with the machine's specific female taper. There is also a way to secure the toolholder in place with a pull stud or a draw bar thread. With CNC machines, the pull stud is more popular because it allows for easier automatic tool changing.

A toolholder consists of five basic components:

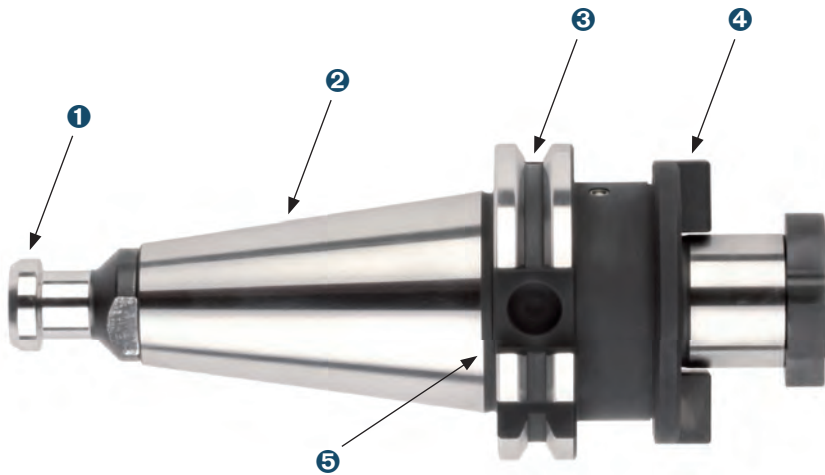

- 1 Pull Stud
- 2 Tapered Shank
- 3 Gripper groove: circular groove
- 4 Adapter
- 5 Opposed Slot

Tapered shank

The standard defines six basic taper shank sizes including SK 30, SK 35, SK 40, SK 45, SK 50, and SK 60.

The proper Taper Shank for the Type of Machine

- ISO 60 Very large machines
- ISO 50 Medium size machines
- ISO 40 Small size machines
- ISO 30 Very small machines

Coolant supply form AD/B

Toolholders form AD/B have internal coolant supply. To use form B (coolant supply through the collar) the two headless screws must be removed and a sealed pull stud must be inserted. To use form AD (central coolant supply) the two headless screws must remain at the collar and a pull stud with drill through must be inserted.

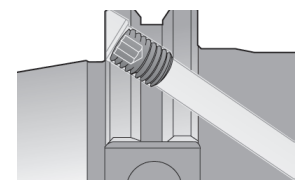



The pull stud allows the locking drawbar of the spindle to pull the toolholder firmly into the spindle and to release the toolholder automatically.

Pull studs are made in various styles and sizes. They are not necessarily interchangeable.

Only use the pull studs that are specified by the machine tool manufacturer.

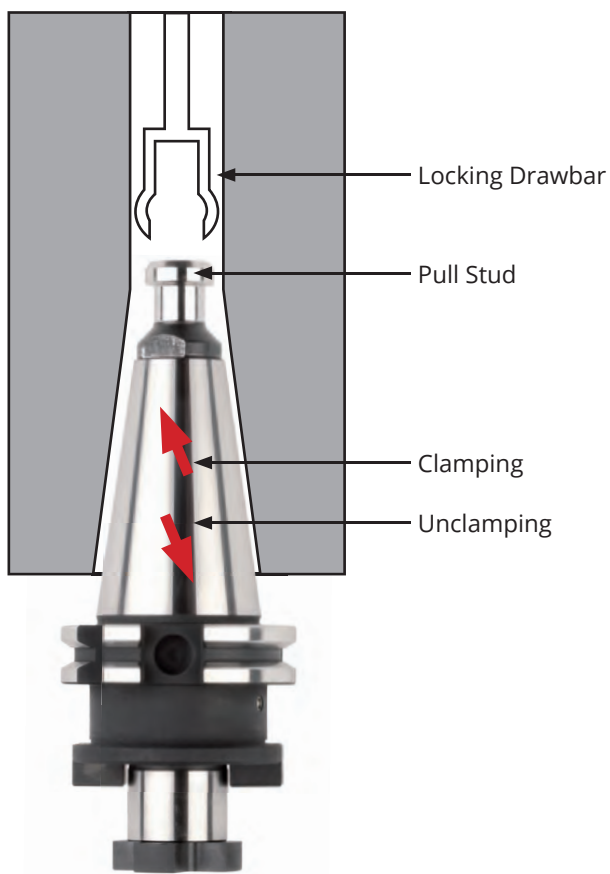

Recommended torque for pull stud tightening:

SK / BT / ISO 30	20 Nm
SK / BT / ISO 40	50 Nm
SK / BT / ISO 50	100 Nm





HSK (hollow taper shanks)



HSK-toolholders DIN 69893

The hollow taper shank (HSK) has prevailed since its standardization as an interface between machine and tool.

HSK benefits to the user include:

- High static and dynamic rigidity
- High precision axial and radial reproducibility
- High tool change accuracy and repeatability
- High speed machining performance
- Short tool changing times
- Coding and identification
- Coolant feed

Balancing recommendations and r.p.m. limits

Kemmler HSK-toolholders are generally pre-balanced to G 6.3/15,000 rev./min.

Fine balancing on request is possible.

Because the rotational speed is the largest influencing factor together with the limits regarding the spindle or spindle bearing interface, the following r.p.m. limits for HSK interfaces have been recommended as guidelines within the HSK standards:

HSK-A/C 32 to 30,000 rev./min

HSK-A/C 40 to 30,000 rev./min

HSK-A/C 50 to 30,000 rev./min

HSK-A/C 63 to 25,000 rev./min

HSK-A/C 80 to 20,000 rev./min

HSK-A/C 100 to 16,000 rev./min

Depending on the tool, it may be necessary to balance both the tool holder and tool when applying the maximum r.p.m. Exact limits can only be determined if machine and spindle manufacturers are taken into consideration and it is possible to define tools and projecting lengths.

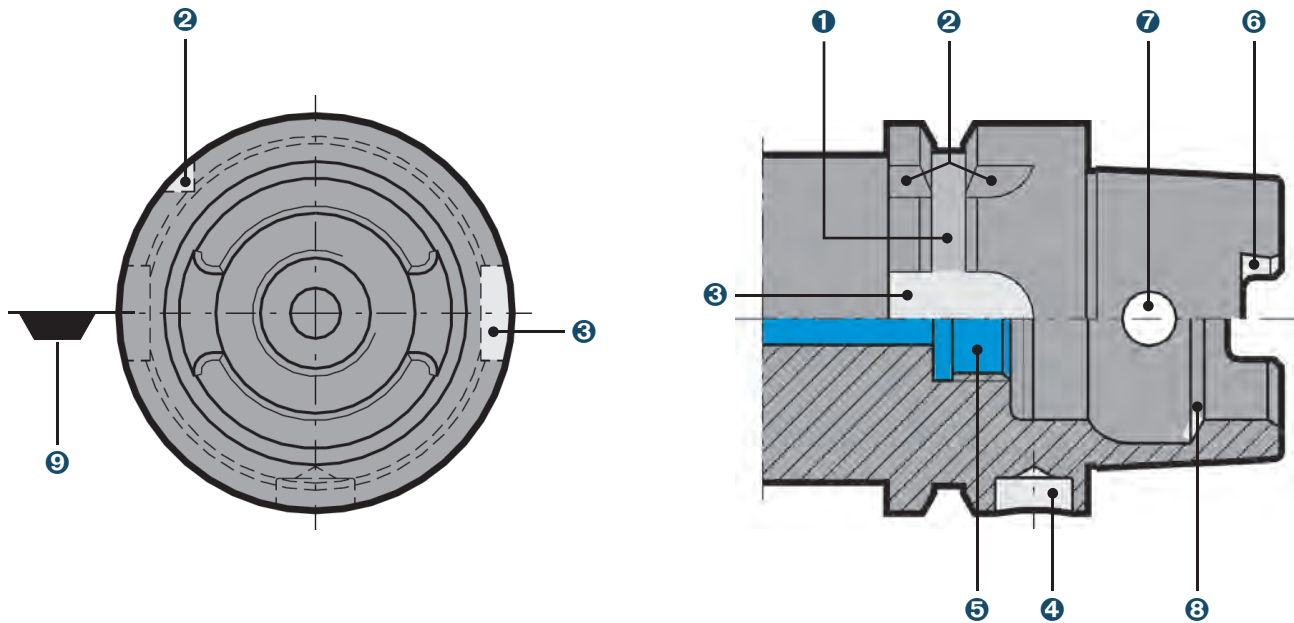

Term definitions of HSK-A interface for automatic tooling systems

- ❶ Gripper groove: circular groove
- ❷ Index notch: sickle-shaped notch across gripper groove
- ❸ Keyway on collar:
index notch or for attachment in tool magazine or grippers.
With HSK-B/D also provides form closed torque transmission to spindle.
- ❹ Coding/identification:
bore in collar for attachment of identification system (coding chip)
- ❺ Thread for coolant: for attachment of coolant supply set
- ❻ Keyway on taper shank: form closed torque transmission to spindle
- ❼ Radial bore in taper shank: necessary for manual clamping systems
- ❽ Clamping shoulder: circular chamfer for drawing in the tool
- ❾ Position of the tool edge of single-edged tools



DIN 69063-1 (ISO 12164-1) Form A

Standard type for machining centres and milling machines. HSK for automatic tool change with gripper groove and index notch. Manual operation is via access hole in taper. Form B relies on driving dogs on the joint face as shank isn't slotted. Torque is transmitted through highly accurate connection.

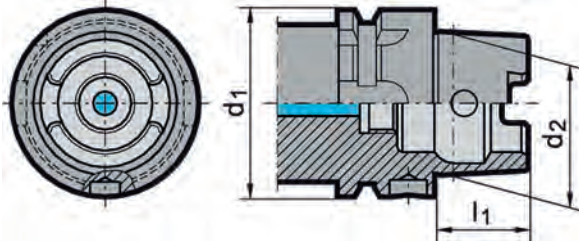

DIN 69063-2 (ISO 12164-1) Form B

For machining centres, milling and turning machines. With enlarged flange size for rigid machining. For automatic tool change. Coolant supply through the flange. Drive keys at the flange. Hole for data carrier DIN STD 69873 at the flange.

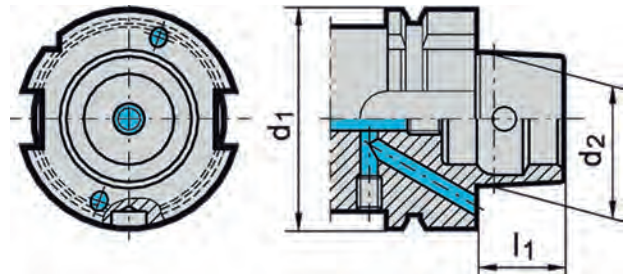

DIN 69063-1 (ISO 12164-1) Form C

For transfer lines, special machines and modular tooling systems. HSK for manual tool change. Operation is via access hole in taper. Form D relies on driving dogs on the joint face as shank isn't slotted. Torque is transmitted through highly accurate connection.

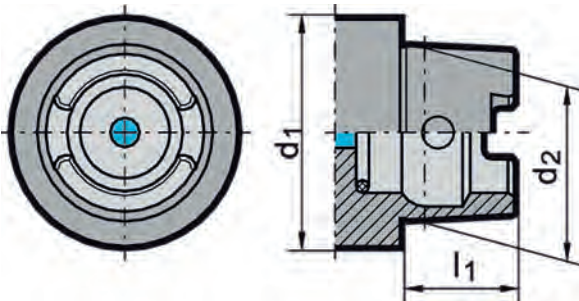

DIN 69063-2 (ISO 12164-2) Form D

For special machines. With enlarged flange size for rigid machining. For manual tool change. Coolant supply through the flange. Drive keys at the flange.

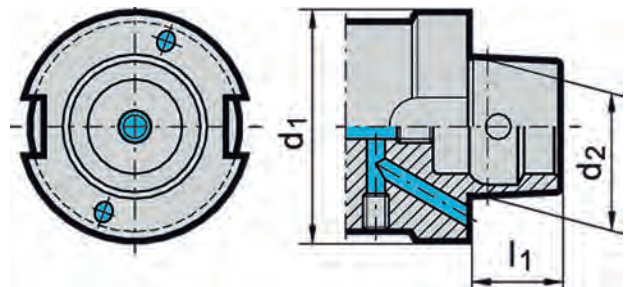

DIN 69063-5 Form E

For high-speed applications. For automatic tool change. HSK for automatic tool change. Torque is transmitted through highly accurate connection. Version with access hole acc. to DIN 69893-1 by arrangement.

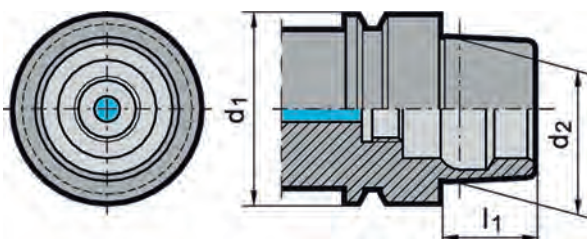

DIN 69063-6 Form F

For high-speed applications mainly in woodworking industries. HSK for automatic tool change. Torque is transmitted through highly accurate connection. Version with access hole acc. to DIN 69893-1 by arrangement.

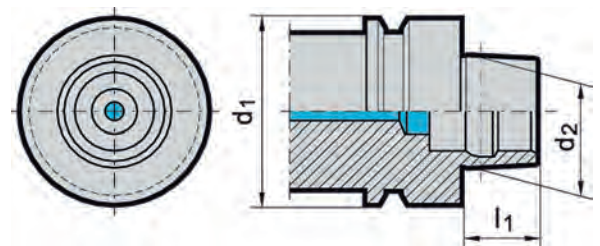



HSK form A, -B or -D holders must be equipped with a coolant tube.
 Using holders without a coolant tube could cause unseen machine spindle damage.
 DIN 69893 Form C, -E and -F do not require a coolant tube. Through coolant and sealing functions are provided by the locking unit.
 The coolant tube is ideally mounted in vertical direction – from the bottom to the top. In this manner the sealing ring is prevented from being compressed during location which would cause the loss of its sealing function.

After mounting, the coolant pipe can be moved only to a minimum degree according to DIN ($\pm 1^\circ$).

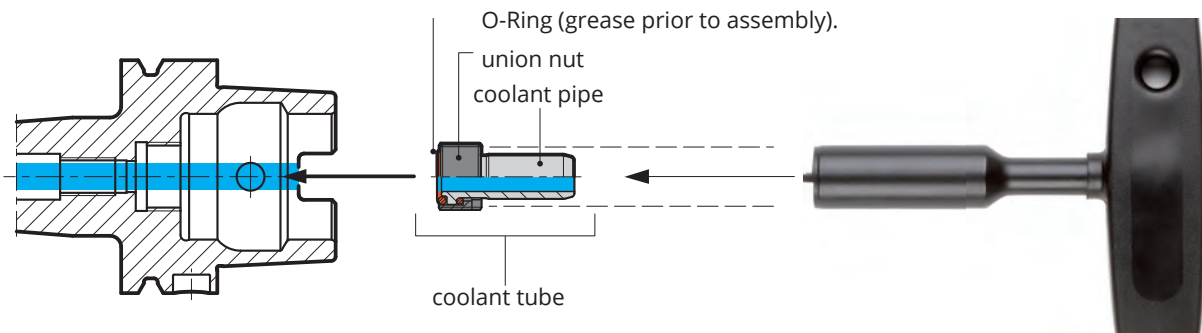

Installation

1. The HSK holder must be clean, free of swarf and undamaged.
2. Grease the O-rings prior to assembly.
3. Centrally insert the complete coolant tube (coolant pipe, union nut and 2 O-rings) in the HSK with the assistance of the socket spanner.
4. Screw in the coolant tube and tighten (see table for torque figures)
5. Check coolant pipe for radial mobility.

Torque figures

for HSK	Mt (Nm)
32	7
40	11
50	15
63	20
80	25
100	30



Imbalance

An imbalance produces a centrifugal force during the rotation of the spindle impeding the smooth running of the tool. This imbalance influences the working process and the life span of the spindle bearings. The centrifugal force F increases linear with the imbalance U and squared with the number of revolutions according to the formula below.

Counter balancing

To compensate for unwanted centrifugal forces, the symmetrical distribution of mass must be restored with the aim of eliminating any centrifugal forces influencing the spindle bearing. Tool holders generally have compensation holes or areas which assist in directing the total amount of all centrifugal forces influencing the axis towards zero (see DIN ISO 1940).

Eccentricity of center of gravity

The imbalance of a spindle causes its center of gravity to deviate a certain distance from the rotating axis in direction of the imbalance. This distance is called rest-eccentricity e or eccentricity of center of gravity. The heavier the weight of the balance body mass m , the greater the restimbalance U permissible.

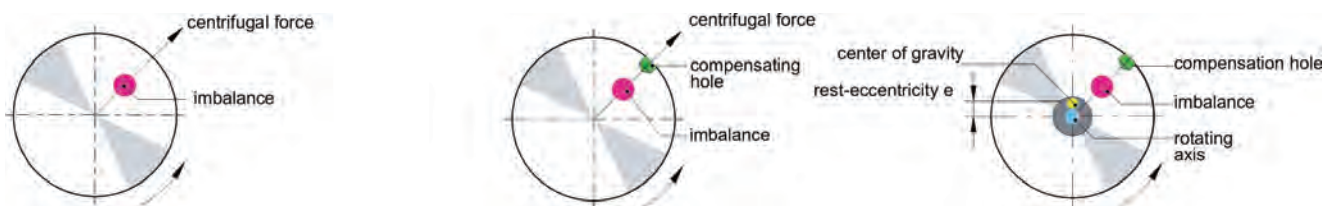

Calculation imbalance

Imbalance is a measure, specifying how much unsymmetrical distributed mass deviates radially from the rotating axis. Imbalance is measured in gmm. The measure of distance e determines the distance of the center of gravity of an element to the rotating axis.

Imbalance is calculated as follows:

$$U = m \times r$$

U = imbalance in gmm

e = eccentricity of center of gravity in μm

m = mass in kg



Balancing limits

In accordance with DIN ISO 1940 the balance grade is denoted with G as well as the units gmm/kg or μm respectively and is relative to the number of revolutions. At a speed of 15,000 rev./min and a weight of 1 kg, G 6.3 corresponds with a permissible center deviation between rotational axis and center of gravity axis of the spindle of $4 \mu\text{m}$. At twice the speed of 30,000 rev./min it would be $2 \mu\text{m}$. If the tool holder was only half the weight, i.e. 0.5 kg, the permissible counter balancing tolerance is also halved. Aim of counter balancing is to find a compromise between the technically feasible and the economically efficient. Because the radial interchange accuracy for a brand-new HSK holder can be 2 to $3 \mu\text{m}$ and for an ISO taper shank holder can be 5 to $10 \mu\text{m}$, it means an initial quality limit of G 2.5 or G 6.3 respectively at 10,000 rev./min.

The following diagram shows the quality grades to DIN ISO 1940-1, i.e. the permissible rest imbalance in relation to the balance body mass for different counter balance qualities G relative to the maximum operating speed.

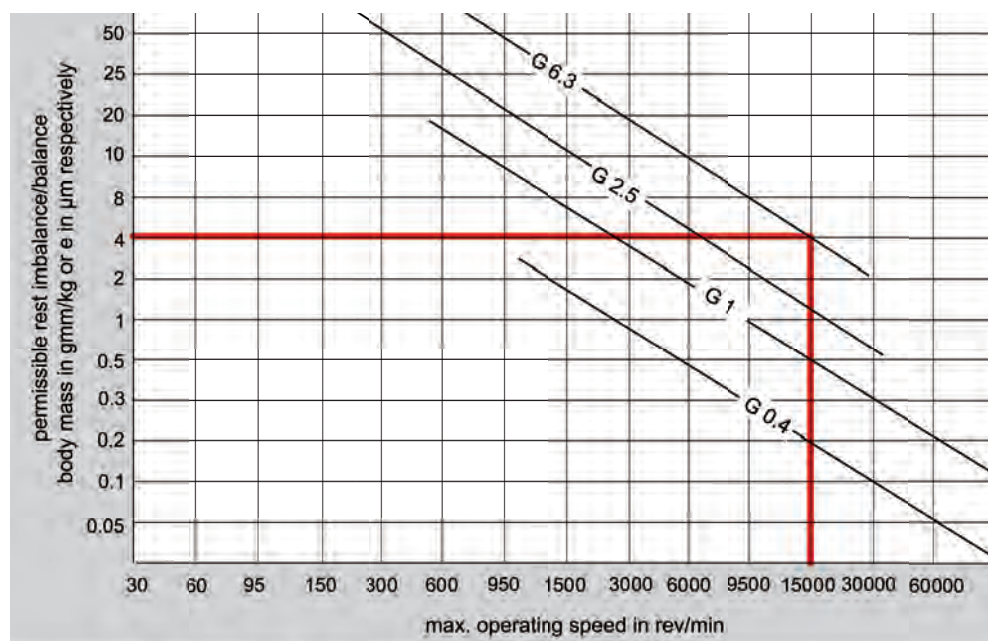

KEMMLER tool holders are balanced to G 6.3/15,000 rev/min.

Fine-balanced with balancing bores in the flange



Pre-balanced with balancing bores at the collar

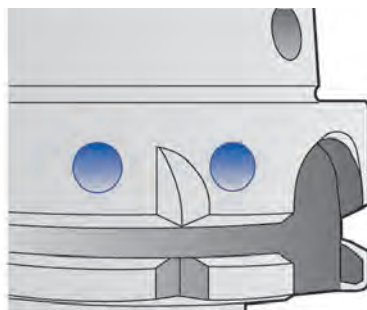

Pre-balanced with balancing flat at the tool body





Modern machining processes place heavy demands on tool holding. Hydraulic expansion chucks provide excellent clamping characteristics combined with precise concentricity. Furthermore, they enable a simple and fast tool change.

Turning the pressure screw generates sufficient pressure in the pressure chamber resulting in an elastic deformation of the clamping bush, providing powerful tool clamping and precise concentricity. A safe and powerful fit is guaranteed. If reduction sleeves are applied that are able to hold varying tool diameters, the tool application may be extended without problem. If such sleeves are not applied, it is essential to observe the minimum clamping length!

Advantages

- precise tool clamping with a maximum 3 µm deviation from concentricity
- transmission of high torque through (excellent clamping) optimised bush clamping system
- high speed compatibility (no centrifugal forces from clamping segments)
- precise concentricity, therefore excellent surface qualities and dimensional accuracy of the workpiece
- rapid tool change thanks to simple operation of the clamping screw
- optimal tool life
- hydraulic cushioning has vibration absorbing effect

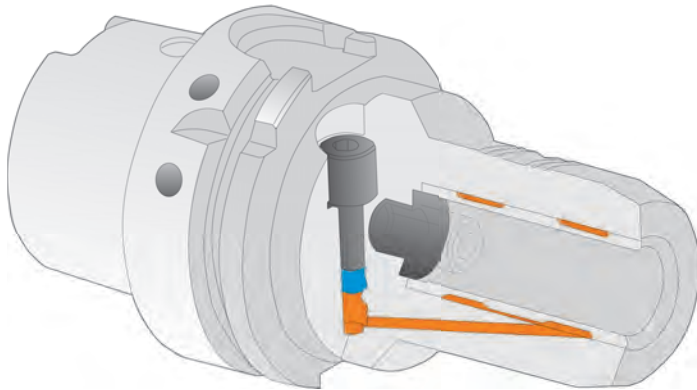

Clamping standard tool shanks to DIN 6535 in hydraulic expansion chucks

	Form HA Ø 6 ... 32 mm	Form HB Ø 6 ... 20 mm
Direct clamping of tool preferred run-out ≤ 0.003 mm		
Clamping of tool shank only with reduction bushes run-out ≤ 0.005 mm	Form HB Ø 25 ... 32 mm	Form HE Ø 6 ... 32 mm



To ensure a flawless function of the hydraulic expansion chucks, please observe the following instructions:

Usage of straight shank tools according to DIN 1835 and DIN 6535 form (HA) and B (HB) up to \varnothing 20 mm shaft diameter with tolerance h_6 , precision grinded $Ra_{min} = 0.3$.

Shafts according to DIN 6535 form HE (Whistle Notch) can only be clamped by using reduction sleeves. All hydraulic expansion chucks are standard balanced to G 6.3 15,000 rev/min.

Clamping and unclamping the tool

1. Clean the holding fixture bore and the tool shaft of grease and dirt. Insert tools up to the end stop. Observe the minimum clamping depth and the length adjustment range.
2. Clamp the shaft by turning the clamping screw up to the end stop. The tool is clamped. To avoid breaking of the hydraulic sleeve, do not carry out clamping action without a tool.
3. To unclamp the tool, turn the screw approx. 5 to 6 revs. counter clockwise and remove the tool.

Note: Never clamp without a clamped tooling!

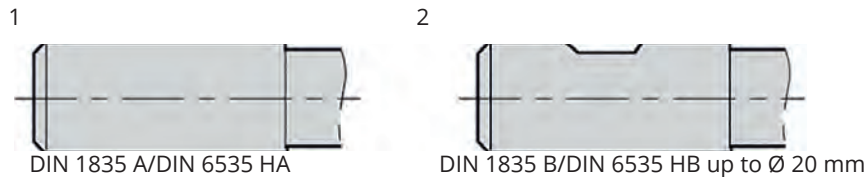

Cleaning

Attention should be paid to the cleanliness of the holding fixture bore and the tool shaft.

Temperature

Optimal temperature range between 10 – 50°. Do not use with temperatures above 80°.

Storage

Store the hydraulic expansion chuck untensioned, cleaned and lightly oiled.

Clamping shafts

Clamp only tool shafts conforming to the requirements of DIN 1835 form A and form B (up to 20 mm).

Torque

Clamping- \varnothing mm	Moment (Nm)	Tolerance of the tool shaft
6	10	h_6
8	10	h_6
10	10	h_6
12	10	h_6
14	10	h_6
16	10	h_6
18	10	h_6
20	10	h_6
25	10	h_6
32	10	h_6





Highest concentricity by using defined torques with Weldon shafts:



Torques for DIN 1835

Bore	Screw	Torque
Ø 6 mm	M 6 SW 3	10 Nm
Ø 8 mm	M 8 SW 4	10 Nm
Ø 10 mm	M 10 SW 5	16 Nm
Ø 12 mm	M 12 SW 6	28 Nm
Ø 14 mm	M 12 SW 6	28 Nm
Ø 16 mm	M 14 SW 6	42 Nm
Ø 18 mm	M 14 SW 6	42 Nm
Ø 20 mm	M 16 SW 8	50 Nm
Ø 25 mm	M 18 × 2 SW 10	60 Nm
Ø 32 mm	M 20 × 2 SW 10	72 Nm
Ø 40 mm	M 20 × 2 SW 10	72 Nm
Ø 50 mm	M 24 × 2 SW 12	90 Nm
Ø 63 mm	M 24 × 2 SW 12	90 Nm



Use clamping and unclamping of tools

To guarantee error-free function of the CNC-drill chuck 08/ 13/ 16, please follow the next instructions.

Attention:

Clamping or releasing only at standstill of machine spindle or outside the machine.

The CNC-drill chuck (pos. 1) is clamped by means of an Allen-T-wrench (pos. 3) on side of the drill chuck actuating a bevel gear. Turn the Allen-T-wrench counter clockwise to open the drill chuck, clockwise to close it.

1st step

Open the jaw of the drill chuck wide enough to insert the cutting tool. (pos. 2)

2nd step

Fit cutting tool (pos. 2) to the stud into the CNC-drill chuck (pos. 1) so that the tool shank is fit closely to the whole length of the clamping jaws. (picture 1)

3rd step

Turn the Allen-T-wrench (pos. 3) clockwise to clamp the cutting tool using a torque of 15 Nm (10 Nm for 0,5-8) to clamp the tool properly. (picture 2)

Note:

Do not use any kind of extensions for clamping. By using a torque higher than mentioned the bevel gear can be damaged. In this case the bevel pinion will be the rated break point to protect the drill chuck against damage.

4th step

Test the concentricity after clamping and make sure that the tool is clamped safely.

Note:

Do not clamp tools with tapered shafts.

5th step

The CNC-drill chuck is ready for work and can be clamped into the machine spindle. (picture 3)

6th step

To release the cutting tool please turn the Allen-T-wrench counter clockwise and remove the cutting tool. (picture 3)

Maintenance and Cleaning

The CNC-drill chucks 08 / 13 / 16 are maintenance-free.

The CNC-drill chucks 08 / 13 / 16 should be cleaned after use with a clean cloth to prevent corrosions.

Before storing the drill chucks please spray oil on the surface to prevent corrosion.

Repair

In case of a damage of the CNC-drill chuck, please send it back to us. We will principally exchange the complete drill chuck head.

With this procedure you will get the quickest possible replacement and only on this way a proper function and a run-out accuracy of < 0.03 mm can be guaranteed.



picture 1



picture 2



picture 3



Assembling instructions:

Insert groove of collet into eccentric ring of the clamping nut at the mark on the bottom of the nut. Push collet in the direction of the arrow until it clicks in place. Screw nut with collet onto toolholder. We recommend to tighten the nut with a torque wrench.

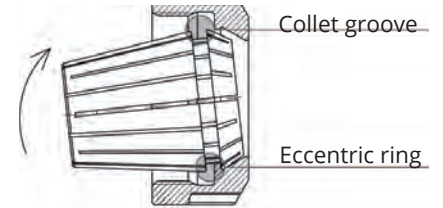

Disassembling instructions:

After the nut is unscrewed from the toolholder, press on the face of the collet while simultaneously pushing sideways on the back of the collet until it disengages from the clamping nut.

Improper assembly can permanently destroy the concentricity of the collet and may result in a damaged clamping nut.

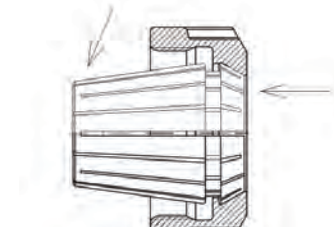

Note:

Only mount nuts with correctly inserted collets! Never place the collet into the holder without first assembling it into the nut.

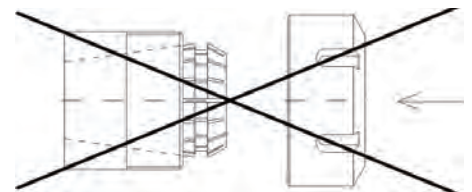

Never clamp oversize tool shanks!

e.g. never use a \varnothing 12-11 mm collet to clamp a \varnothing 12.2 mm shank. Rather use the next bigger collet (here \varnothing 13-12 mm collet).

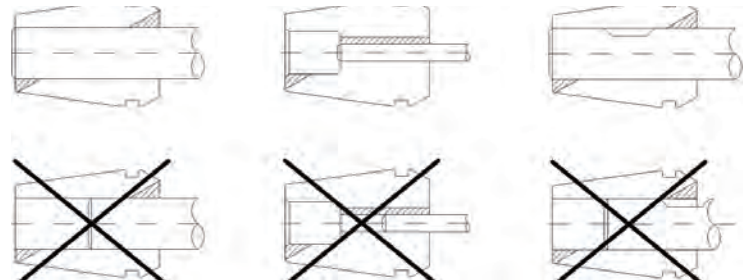

Insert tool the full length of the collet for best results if possible. However, never insert tool less than 2/3 of the collet bore length. Improper tool insertion can permanently deform the collet and will result in poor runout.

Maximum torque

ER 16	M22 × 1,5	50 Nm
ER 20	M25 × 1,5	75 Nm
ER 25	M32 × 1,5	85 Nm
ER 32	M40 × 1,5	105 Nm
ER 40	M50 × 1,5	150 Nm
ER 11 Mini	M13 × 0,75	18 Nm
ER 16 Mini	M19 × 1	28 Nm

Please observe the maximum torque indicated in the chart!



Assembly

Insert the small diameter of the disc into the centre of the coolant nut and apply even pressure until the disc is properly seated into the nut. The disc must be flush with the outside of the nut.

Removal

To remove the disc, simply press on the outside of the disc evenly, until it snaps out.

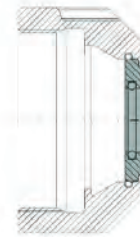
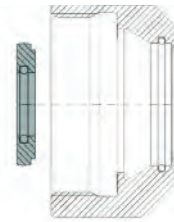

Bezeichnung Designation Désignation	E	EP	EA	EC	ECC	EH	ESP	G	GA	GC
Rundlauf Concentricity Concentricité	≤ 15 µ	≤ 5 µ	≤ 15 µ	≤ 15 µ	≤ 15 µ	≤ 15 µ	≤ 5 µ	≤ 15 µ	≤ 15 µ	≤ 15 µ
Spanndurchmesserüberbrückung Collapse Plage de serrage	0,5-1 mm	0,5-1 mm	h8	h8	h8	h8	h8	h8	h8	h8
Rostfrei Stainless Inoxydable	-	-	-	-	-	-	X	-	-	-
Abdichtung für IK (Innenkühlung) Sealing for IC (inner coolant supply) Avec joint d'étanchéité pour AC	-	-	X	-	-	X	-	-	X	-
Kühlkanalbohrung für IK (Innenkühlung) Jet holes for Inner Coolant Supply Avec canaux d'arrosage au centre	-	-	-	X	X	-	-	-	-	X
Innenvierkant für Gewindebohrer For tapping with internal square drive Pour taraudage avec carré d'entraînement	-	-	-	-	-	-	-	X	X	X

K Quick-change tapping chucks



The process of tapping is a complex balance of rotational and axial movements of the tool. It is sometimes necessary to restrict the axial movements of the tool.

If the axial movement is not accurately controlled, the leading or trailing flanks of the tap may be forced to progressively "shave" one flank of the component thread, thus producing a thin and oversize thread in the component.

Tension – forward float capability allows the tap to progress into the component without interference from the axial feed of the machine spindle.



Compression – backward float capability, acts as a cushion and allows the tap to commence cutting at its own axial feed independent of the machine spindle.



Compression/Tension – float is designed to negate any external forces during the machining operation.



Radial float – allows for slight misalignment of the machine spindle axis and hole axis prior to tapping. This is not recommended manufacturing practice and should be avoided.





For a correct use of the tapping chuck, please check, during the first thread, not to exceed the max. axial stroke of the compensation values. This is to avoid damaging the thread or the tapping chuck.

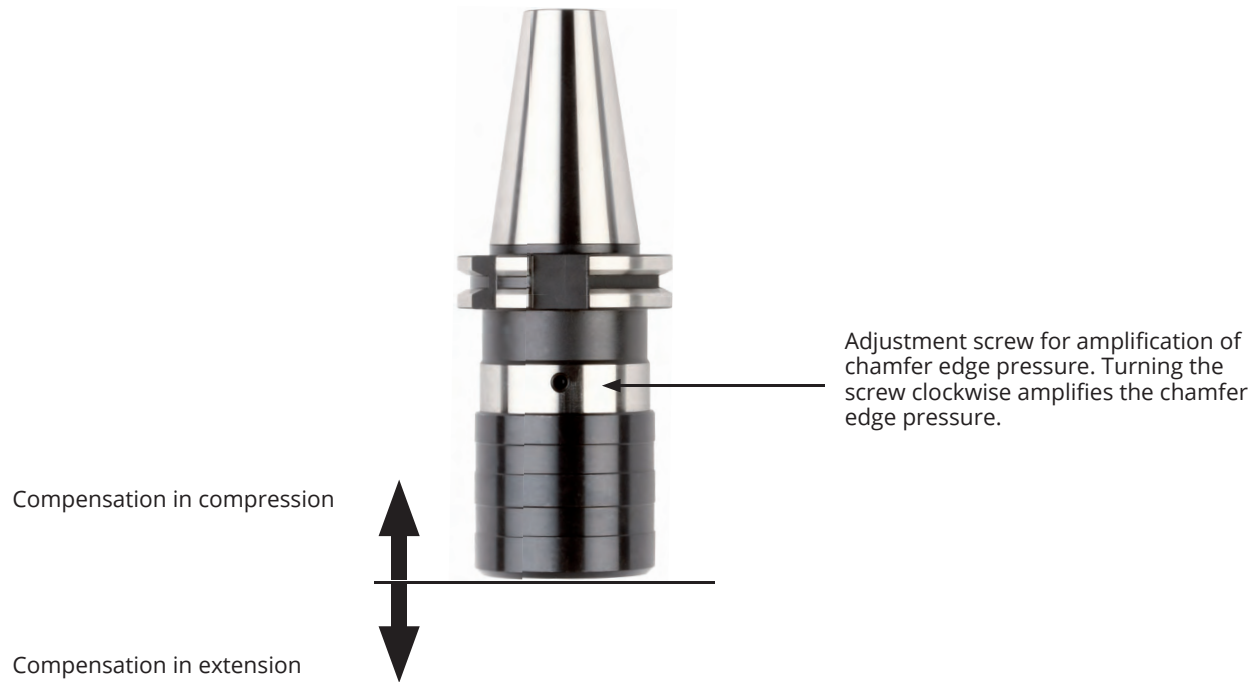

Code	Tap capacity	Adapters	Length adjustment in mm on	
			Compression	Extension
xxx.16.12	M 3- M14	16.11.xx / 16.01.xx	7	7
xxx.16.20	M 5 - M22	16.12.xx / 16.02.xx	12	12
xxx.16.36	M14 - M36	16.14.xx / 16.03.xx	17.5	17.5



Screw taps-shaft size



Shaft diameter					
Ø × □	DIN 352	DIN 5157	DIN 371	DIN 374	DIN 376
Ø 2.5 × 2.1 □	M1		M1	M3	M3.5
Ø 2.5 × 2.1 □	M1.1		M1.1	M3.5	
Ø 2.5 × 2.1 □	M1.2		M1.2		
Ø 2.5 × 2.1 □	M1.4		M1.4		
Ø 2.5 × 2.1 □	M1.6		M1.6		
Ø 2.5 × 2.1 □	M1.8		M1.8		
Ø 2.8 × 2.1 □	M2		M2	M4	M4
Ø 2.8 × 2.1 □	M2.2		M2.2		
Ø 2.8 × 2.1 □	M2.5		M2.5		
Ø 3.5 × 2.7 □	M3		M3	M5	M5
Ø 4 × 3 □	M3.5		M3.5		
Ø 4.5 × 3.4 □	M4		M4	M6	M6
Ø 6 × 4.9 □	M5		M5		
Ø 6 × 4.9 □	M6		M6		
Ø 6 × 4.9 □	M8			M8	M8
Ø 7 × 5.5 □	M10	G 1/8"		M10	M10
Ø 8 × 6.2 □			M8		
Ø 9 × 7 □	M12			M12	M12
Ø 10 × 8 □			M10		
Ø 11 × 9 □	M14	G 1/4"		M14	M14
Ø 12 × 9 □	M16	G 3/8"		M16	M16
Ø 14 × 11 □	M18			M18	M18
Ø 16 × 12 □	M20	G 1/2"		M20	M20
Ø 18 × 14.5 □	M22	G 5/8"		M22	M22
Ø 18 × 14.5 □	M24			M24	M24
Ø 20 × 16 □	M27	G 3/4"		M27	M27
Ø 22 × 18 □	M30	G 7/8"		M30	M30
Ø 25 × 20 □	M33	G 1		M33	M33
Ø 28 × 22 □	M36	G 1 1/8"		M36	M36
Ø 32 × 34 □	M39	G 1 1/4"		M39	M39
Ø 32 × 24 □	M42			M42	M42
Ø 36 × 29 □	M45	G 1 3/8"		M45	M45
Ø 36 × 29 □	M48	G 1 1/2"		M48	M48
Ø 36 × 29 □		G 1 3/4"			
Ø 36 × 29 □		G 2"			

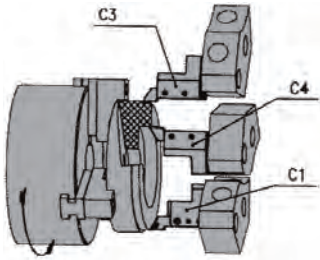

Application of radial tool holders with counter clockwise spindle rotation

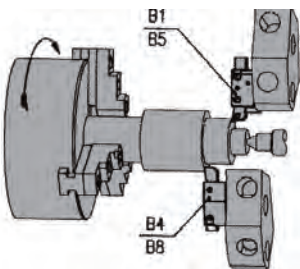

Application of radial tool holders with clockwise spindle rotation

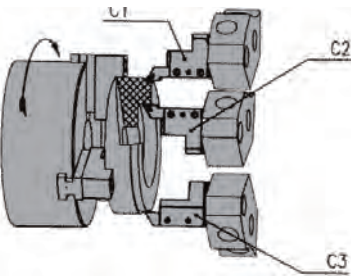

Application of axial tool holders with counter clockwise spindle rotation

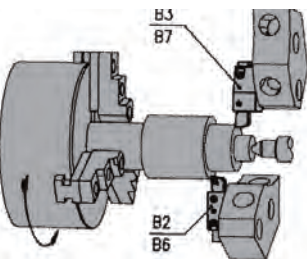

Application of axial tool holders with clockwise spindle rotation

K High precision collet chucks KPS-system



The high precision collet chuck (KPS) is the alternative to hydraulic expansion chucks and shrink chucks.
 High flexibility due to interchangeable collets (precision collets System KPS available from Ø 0.5 up to 16 mm).
 High clamping forces and concentricity lead to top surfaces and longer tool life.
 Plain clamping nut without grooves for high speed machining.
 Slim version.

Tool shanks:

Cylindrical DIN 1835-1 form A/DIN 6535 form HA, tolerance h_8 .
 Dedicated clamping size on the nominal diameter. Collets available in steps of 0.5 mm.

Run-out:

Maximum runout when measured at a gauge projection of $4 \times d$ in relation to the external taper is $5 \mu\text{m}$.

Balancing:

Fine balancing is standard ($G 2.5 \text{ } 30,000 \text{ min}^{-1}$).

Note:

KPS-system chucks are delivered as standard without stop end screws.
 The use of stop end screws is not recommended at high spindle speeds, e.g. over 10,000 rpm.



Collet chuck size	Capacity d mm	D	L ₁	M	S	Max. tightening torque	D type clamping system max. Rpm*
D16	1 - 10	27	19	M20 × 1	24	40 Nm	60,000
D24	2 - 16	36	22	M28 × 1	32	70 Nm	40,000

* The maximum rpm for holders equipped with this clamping system is often restricted by the holder's back-end taper type and size.



Transmittable static torque to the tool shank (Nm)

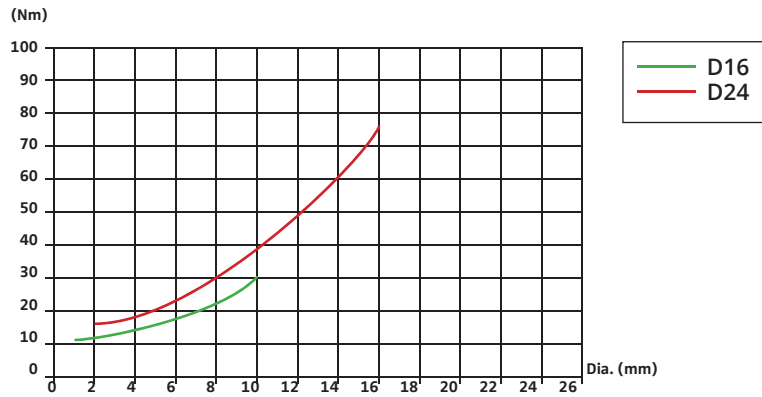

Assembly advice for KPS-system collets with a collet extractor

1. Remove the nut from the chuck.
2. Insert and squeeze the collet into the collet extractor.*
3. Insert the unit collet + ring into the nut until stop end.
4. Push the back end of the collet to remove the unit collet + nut from the ring.
5. Mount the nut together with the collet on the collet chuck.



To dismantle, push unit collet + nut into the collet extractor in order to squeeze the collet. Remove the nut.

Finally, push the back end of the collet to remove it from the collet extractor.

The collet must always be inserted into the nut, and the nut screwed onto the chuck before introducing the tool into the collet.

Never lock the nut without a tool shank located in the full length of the collet.



KPS-Collet



KPS-Collet extractor



KPS-Collet nut



KPS-Wrench



High-performance milling chucks HKS-system



The high-performance milling chucks are suitable for almost all applications. Especially in heavy roughing we guarantee unsurpassed high clamping forces and high process reliability. HKS power chucks lead through the rigidity of the chuck, its concentricity and clamping even at 3 mm from nose lining to excellent surface finish and high tool life. All HKS chucks grant a maximum deviation of concentricity of 3 µm at 3 x D.

Application:

- heavy roughing
- finish milling
- hard milling
- drilling, reaming
- thread milling

Concentricity:

Max. deviation of concentricity 3 µm at 3 x D of the clamped tool.

Balancing:

standard fine-balanced (G 6,3 15.000 min⁻¹).

Clamping shank:

All available tool shanks with or without Weldon shank can be clamped directly or with an adapter sleeve.

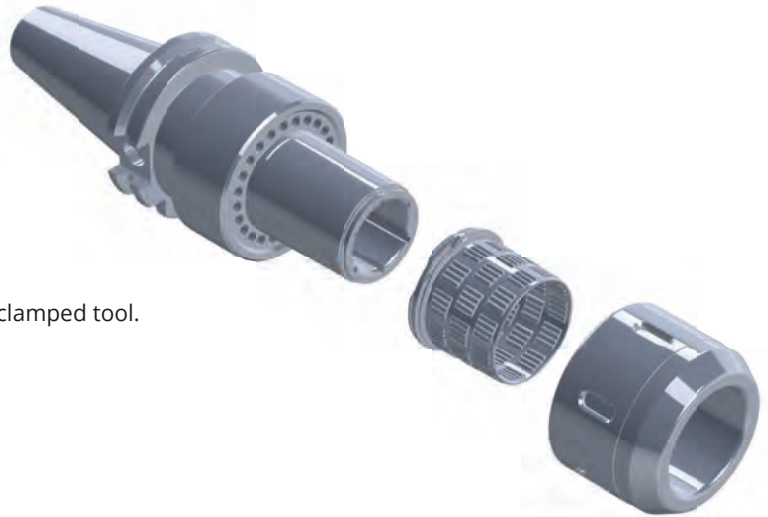

Size	20mm	25mm	32mm
Clamping torque	50-70 Nm	80-100 Nm	80-100 Nm
Clamping force	780 Nm	2000 Nm	2000 Nm





RELEASE THE BEAST



KEMMLER

K KEMMLER®
Präzisionswerkzeuge



Example:

40 3 . 02 . 20 . 1

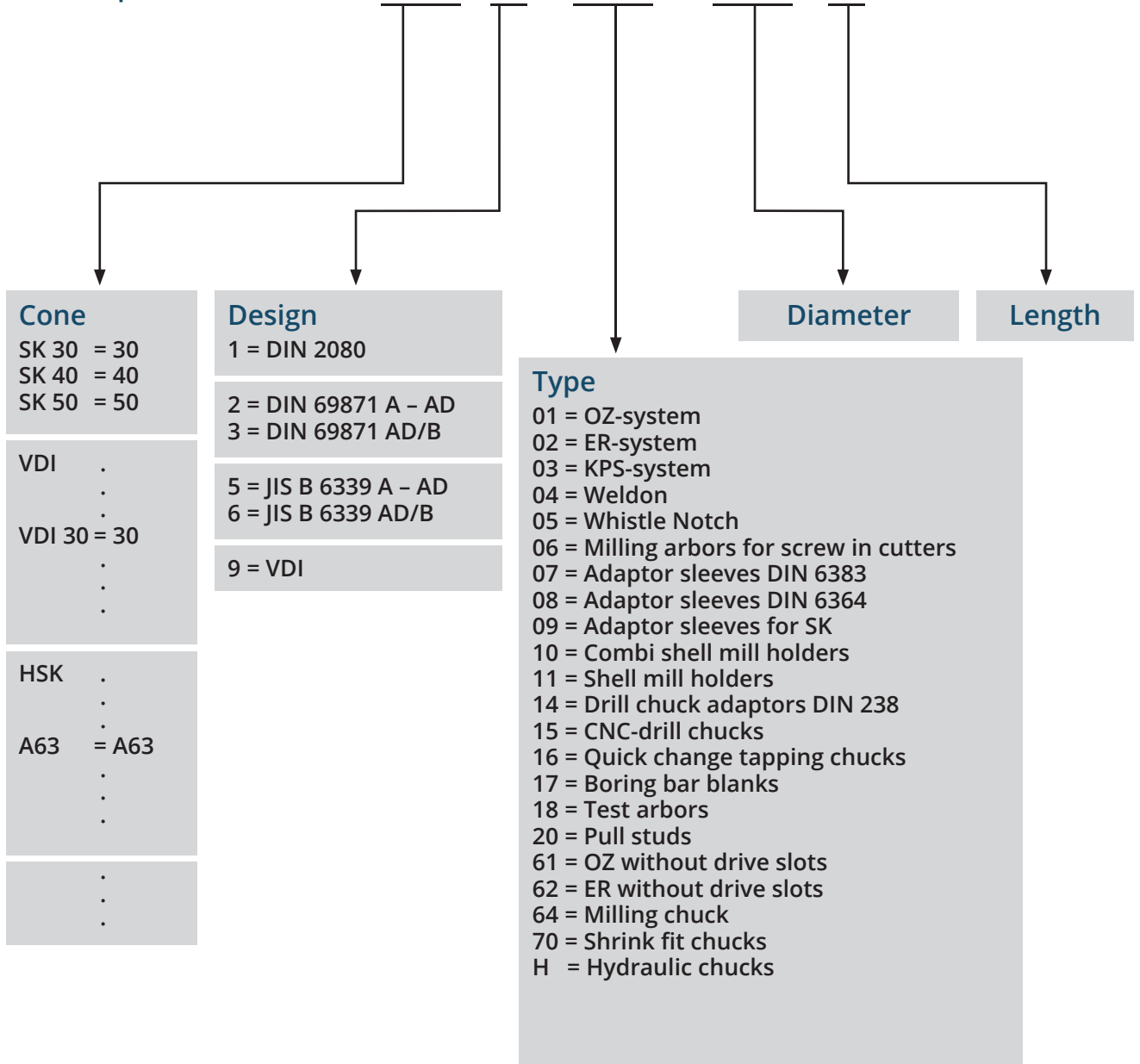



Cône trempé _____	14.53
Tirettes _____	14.54
HSK (cône face creux) _____	14.55
Sommaire HSK (cône face creux) _____	14.57
Canules de lubrification HSK _____	14.58
Effets d'équilibrage sur les broches, les attachements et les outils _____	14.59
Mandrins expansibles hydrauliques _____	14.61
Mode d'emploi et instructions de service pour mandrins expansibles hydrauliques _____	14.62
Couples pour le serrage du fraises Weldon _____	14.63
Mode d'emploi et instructions de service pour mandrins de perçage CNC _____	14.64
Mode d'emploi pour pinces de serrage selon DIN 6499 _____	14.65
Instructions de montage de joints _____	14.66
Mandrins de taraudage _____	14.67
Instructions d'utilisation appareil à tarauder _____	14.68
Pour taraud-taille de la tige _____	14.69
Assignment des outils pour machines avec tourelle à disque _____	14.70
Mandrins à pinces de précision système KPS _____	14.71
Mandrin de serrage à haute performance système HKS _____	14.73
Marquage laser de porte-outils _____	14.74
La clé Kemmler pour déchiffrement _____	14.75



De nombreuses machines manuelles et CNC utilisent des attachements qui ont été créés précisément avec un cône mâle qui s'emboîte dans le cône femelle de la machine. Il y a également un moyen de sécuriser l'attachement en place avec une tirette. Celle-ci est plus utilisée avec une machine CNC puisqu'elle permet un changement automatique d'outil plus facile.

Un porte-outil se compose de cinq éléments:

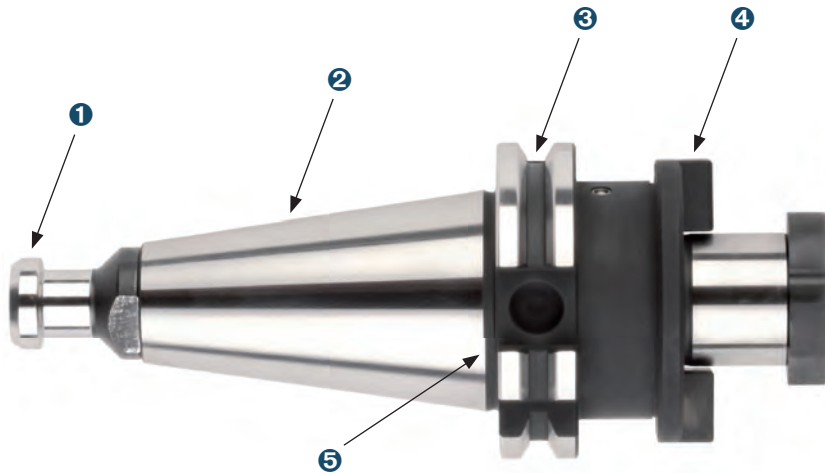

- ❶ Tirette
- ❷ Queue conique
- ❸ Collerette : rainure périphérique en V
- ❹ Adaptateur
- ❺ Rainure opposée

Queue conique

La norme définit six tailles de queues coniques incluant SK 30, SK 35, SK 40, SK 45, SK 50, et SK 60.

La queue conique correcte selon le type de machine

- ISO 60 très grosses machines
- ISO 50 Machines de taille moyenne
- ISO 40 Machines de petite taille
- ISO 30 Très petites machines

Arrosage forme AD/B

Porte-outils en forme AD/B disposent d'un arrosage interne. Chez forme B (arrosage par la collerette) il faut enlever les deux bouchons d'étanchéité et utiliser une tirette sans perçage. Chez forme AD (arrosage centrale) il faut laisser les deux bouchons d'étanchéité dans la collerette et utiliser une tirette perçée.

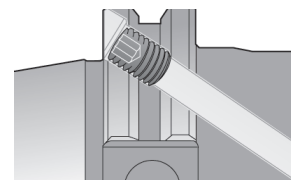

La tirette permet à la barre de serrage de tirer fermement le porte-outil dans la broche et de le dégager automatiquement.

Les tirettes sont fabriquées dans différents types et différentes tailles. Ils ne sont pas nécessairement interchangeables.

Utiliser uniquement les tirettes qui sont spécifiées par le fabricant de la machine outil.

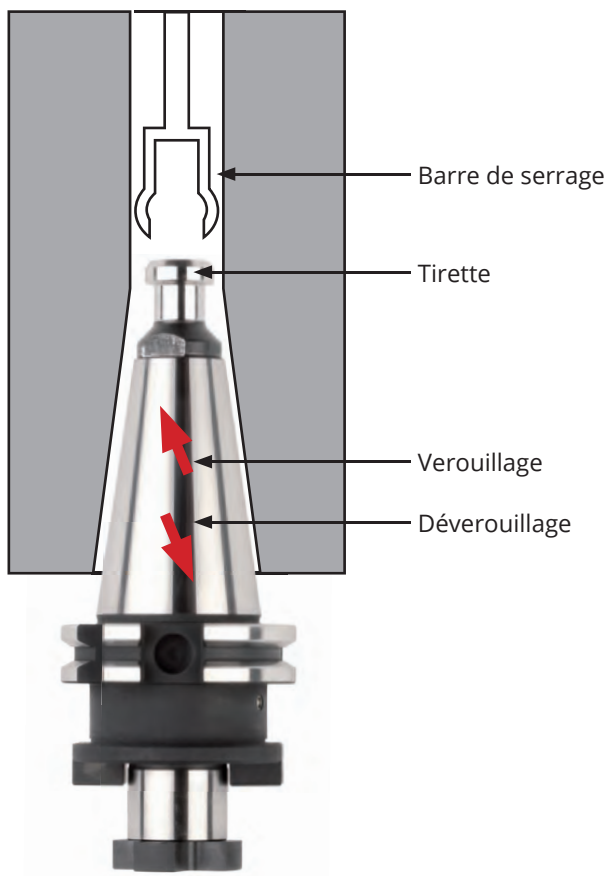

Couple de serrage recommandé pour le montage de tirettes:

SK / BT / ISO 30 20 Nm

SK / BT / ISO 40 50 Nm

SK / BT / ISO 50 100 Nm





Porte-outils HSK DIN 69893

Le cône face creux (HSK) s'était établi depuis la standardisation comme interface entre la machine-outil et l'outil.

Les avantages de l'HSK pour l'utilisateur incluent:

- Rigidité hautement statique et dynamique.
- Reproductibilité axiale et radiale de haute précision.
- Exactitude invraisemblable aux changements répétés
- Bon comportement à haute vitesse
- Temps de changement extrêmement courts
- Codification, identification
- Alimentation de la lubrification

Conseils d'équilibrage et limites des vitesses de rotation

Porte-outils HSK de Kemmler sont pré-équilibré de principe à G 6,3 15.000 tr./mn.

Équilibrage fin si besoin est possible.

La vitesse de rotation est le facteur le plus important qui influence considérablement le comportement des broches, attachements et roulements dont les limites sont connues et c'est pourquoi, lors de la normalisation des HSK, des vitesses de rotation maximales ont été retenues comme suit:

HSK-A/C 32 jusqu'à 30.000 tr./mn

HSK-A/C 40 jusqu'à 30.000 tr./mn

HSK-A/C 50 jusqu'à 30.000 tr./mn

HSK-A/C 63 jusqu'à 25.000 tr./mn

HSK-A/C 80 jusqu'à 20.000 tr./mn

HSK-A/C 100 jusqu'à 16.000 tr./mn

En fonction de l'outil, à vitesses de rotation maximales, il est parfois nécessaire d'équilibrer l'ensemble, mandrin et outil. Des valeurs précises à ce sujet ne peuvent être déterminées que si la machine et la broche de la machine ont été prises en considération ainsi que le type d'outil et sa longueur dépassant le mandrin de serrage.

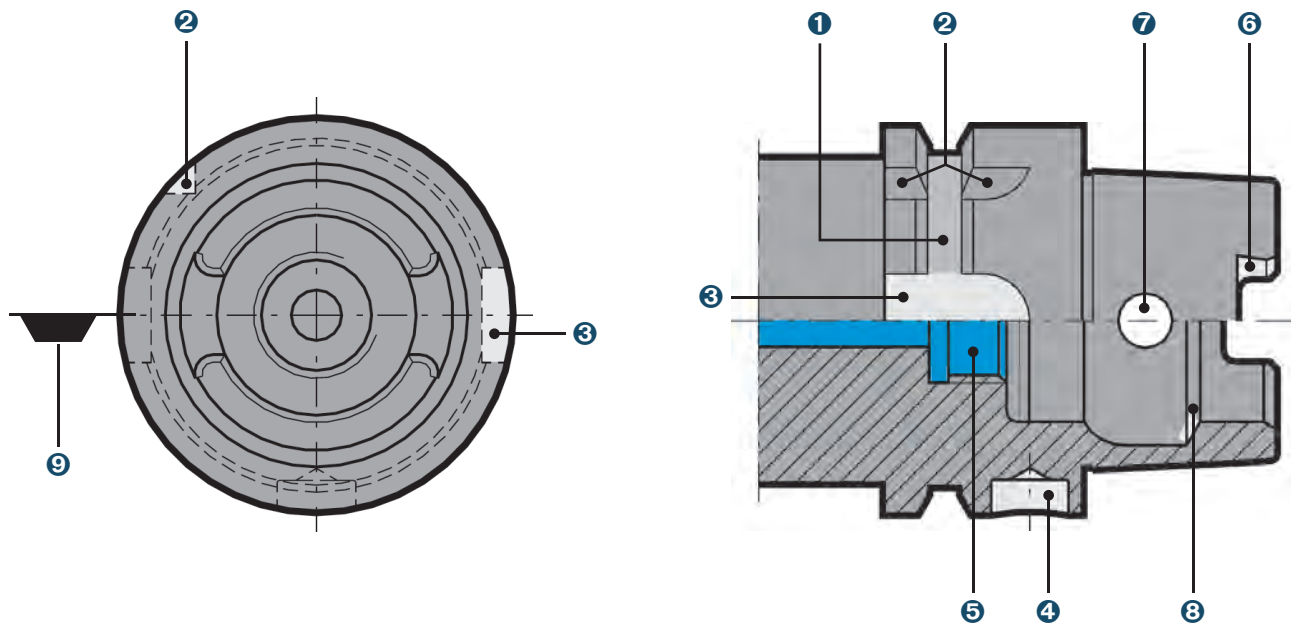

Définition des mots techniques de l'attachement automatique HSK-A

- ❶ Collerette : rainure périphérique en V é
- ❷ Rainure d'indexage : rainure transversale sur collerette
- ❸ Rainure d'entraînement, d'indexage et de prise sur l'échangeur.
Pour les formes HSK B et D, afin d'assurer le couple.
- ❹ Cavité : emplacement pour le microprocesseur
- ❺ Perçage et filetage : montage de l'adducteur de la lubrification centrale
- ❻ Rainures sur le cône : renforçant l'entraînement du système
- ❼ Orifice radial : passage de la clé pour le serrage manuel
- ❽ Gorge de préhension :
chanfrein incliné servant d'appui aux mors de serrage
- ❾ Position de la lame d'outil chez outils à un seul tranchant



DIN 69063-1 (ISO 12164-1) Forme A

Typ standard pour centres d'usinage et machines de fraisage. Cône face creux pour le changement automatique des outils avec colerette et rainures de positionnement (Possibilité d'utilisation manuelle puisqu'orifice radial dans le cône afin de permettre le passage de la clé de serrage). Encoche pour un support donné DIN STD 69873 dans la colerette. Le couple extrême est assuré.

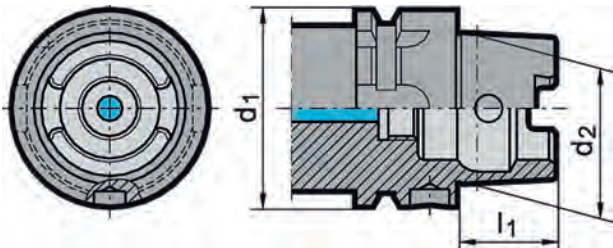

DIN 69063-2 (ISO 12164-1) Forme B

Pour les centres d'usinage, les machines de fraisage et de tournage. Avec des dimensions de colerettes élargies pour un usinage rigide. Pour un changement d'outil automatique. Lubrification à travers la colerette. Encoche pour un support donné DIN STD 69873 à la colerette.

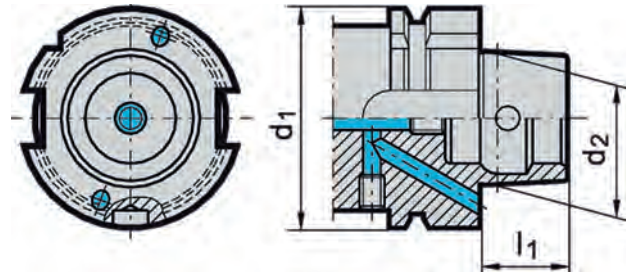

DIN 69063-1 (ISO 12164-1) Forme C

Pour les centres d'usinage, les machines de fraisage et de tournage. Cône face creux pour le changement manuel des outils (serrage manuel par l'orifice radial sur le cône). Depuis que tous les porte-outils forme A sont équipés d'encoches de côte pour un changement d'outil manuel, ils peuvent être aussi utilisés comme porte-outils de forme C. Le couple extrême est assuré.

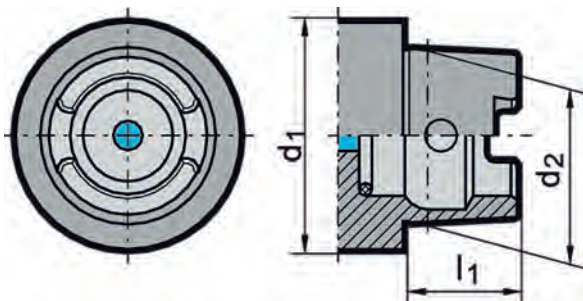

DIN 69063-2 (ISO 12164-2) Forme D

Pour des machines spéciales. Avec des dimensions de colerette élargies pour un usinage rigide. Pour un changement manuel d'outil. Lubrification à travers la colerette.

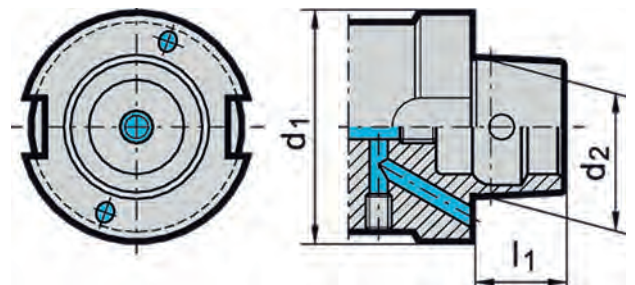

DIN 69063-5 Forme E

Pour des applications à grande vitesse. Cône face creux pour le changement automatique des outils. Le couple extrême est assuré. Version pourvue de l'orifice radial selon la norme DIN 69893-1 selon accord, si convenu.

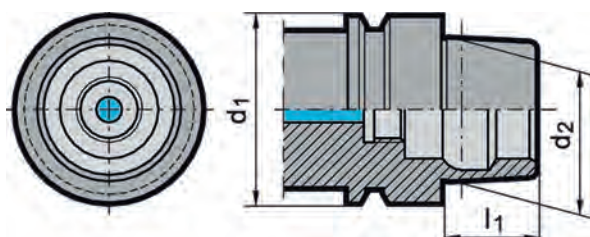

DIN 69063-6 Forme F

Pour des applications à grande vitesse, principalement dans les industries de travail du bois. Cône face creux pour le changement automatique des outils. Avec des dimensions de colerette élargies pour un usinage rigide. Le couple extrême est assuré. Version pourvue de l'orifice radial selon la norme DIN 69893-1 selon accord, si convenu.

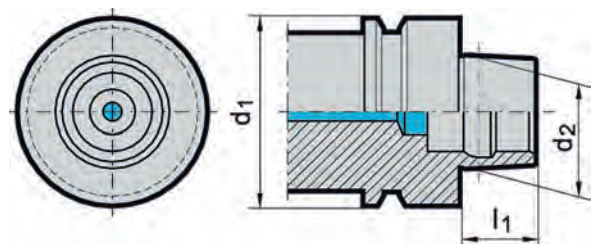

Les porte-outils HSK forme A, -B, ou -D doivent être équipés d'une canule de lubrification central ou d'un bouchon d'obturation.

Utiliser les porte-outils sans canule de lubrification ou bouchon d'obturation, lorsque nécessaire, peut entraîner des dommages inapparents sur la broche de la machine.

Les porte-outils selon DIN 69893 Forme C, -E et -F ne requièrent ni canule de lubrification, ni bouchon d'obturation. Le passage du lubrifiant et l'étanchéité sont réalisés par l'unité de serrage.

Le montage de la canule de lubrification doit se faire en position verticale – du bas vers le haut afin d'éviter le coincement ou la mauvaise mise en place de la rondelle d'étanchéité.

Après le montage, la canule peut être déplacée légèrement ($\pm 1^\circ$).

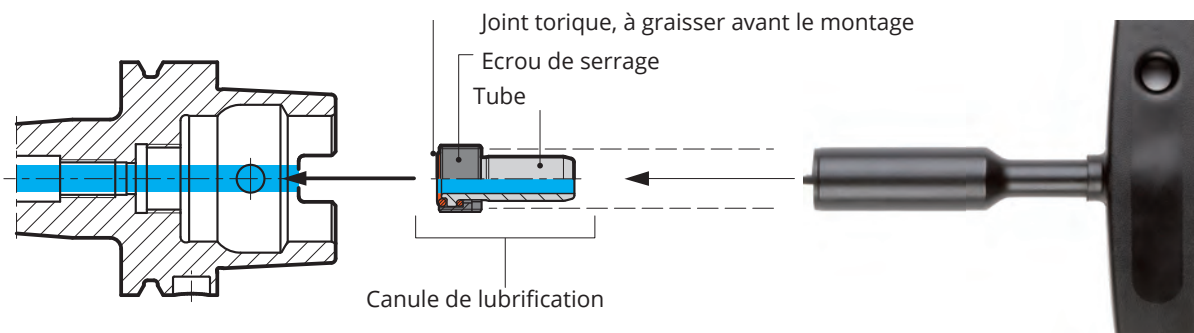

Montage

1. L'attachement HSK doit être propre, sans copeaux et en bon état.
2. Avant le montage, il faut graisser les joints toriques.
3. A l'aide de la clé spéciale, il faut bien centrer et visser l'ensemble canule de lubrification (tube, son écrou de serrage et ses 2 joints toriques) dans l'attachement HSK.
4. Visser et serrer la canule de lubrification avec le couple prescrit selon le tableau à droite.
5. Veiller à ce que la canule de lubrification puisse légèrement radialement pivoter.

Couple de serrage

pour HSK	Mt (Nm)
32	7
40	11
50	15
63	20
80	25
100	30



Le déséquilibre

Sur une broche rotative, le déséquilibre provoque une force centrifuge engendrant des vibrations qui se répercutent sur l'outil. Un tel déséquilibre influence l'usinage et la durée de vie du roulement de la broche. Tandis que les forces centrifuges F sont linéairement proportionnelles au déséquilibre, elles s'accroissent au carré avec la vitesse de la rotation, selon la formule ci-dessous.

Equilibrer

Eliminer les forces centrifuges signifie compenser, répartir symétriquement la masse autour de son axe de rotation, de façon à ce qu'il n'y ait plus de balourd, recentrer le point de gravité. Sur les attachements, l'on réalise des percages ou des méplats de compensation. Ainsi, les forces centrifuges résultantes se recentrent vers le point „zéro“ qui lui, est l'axe de rotation (voir DIN – ISO 1940)

Décalage du centre de gravité

Le balourd sur une broche est excentrique par rapport à son axe symétrique et est localisé par un intervalle; sa définition est: Valeur de l'excentricité e ou, décalage du centre de gravité e . Le taux du déséquilibre (U) est dépendant de la valeur du balourd (m) et de sa localisation.

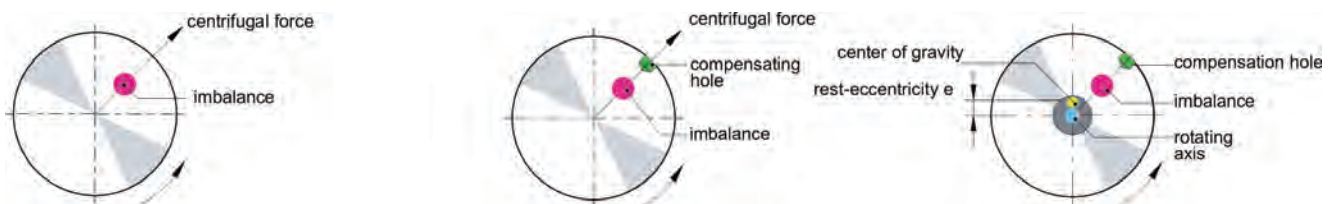

Calcul de déséquilibre

Le déséquilibre est une valeur qui indique le degré de répartition asymétrique en direction radiale par rapport à l'axe de rotation. Cette valeur es donnée en gmm. La valeur de l'intervalle „ e “ indique la distance d'éloignement du centre de gravité d'une pièce par rapport à l'axe de rotation.

La valeur du déséquilibre „ U “ résulte de la formule:

$$U = m \times e$$

U = déséquilibre en gmm

e = intervalle centre de gravité en μm

m = masse en kg

Limites d'équilibrage

Selon la norme DIN ISO 1940, la lettre „G” et la valeur „gmm/kg ou μm ” représentent la qualité d'équilibrage rapportée à une certaine vitesse de rotation de 15.000 tr./mn d'un attachement avec un poids de 1 kg, G 6,3 représente une valeur de l'intervalle entre le balourd et l'axe de rotation de 4 μm . En doublant la vitesse de rotation à 30.000 tr./mn, cette valeur serait de 2 μm . Dans le cas où l'attachement ne pèserait que 0,500 kg, cette valeur serait aussi divisée par 2! Le but de l'équilibrage est de trouver un compromis entre ce qui est techniquement réalisable et ce qui est significatif, ce qui a du sens. Lors de l'échange d'un attachement HSK en excellent état, la précision de la répétitivité es de 2 à 3 μm et celle du cône SA de 5 à 10 μm , cela signifie un valeur d'équilibrage similaire à G 2,5 voire G 6,3 à 10.000 tr./mn.

Le diagramme d'équilibrage suivant démontre la qualité d'équilibrage selon la norme DIN ISO 1940 / 1 donc le balourd résiduel admis par rapport à la masse complète à équilibrer, poids de l'attachement pourvu de son outil, pour différentes qualités d'équilibrage G en tenant compte de la vitesse de rotation maximale de l'ensemble lors de l'utilisation.

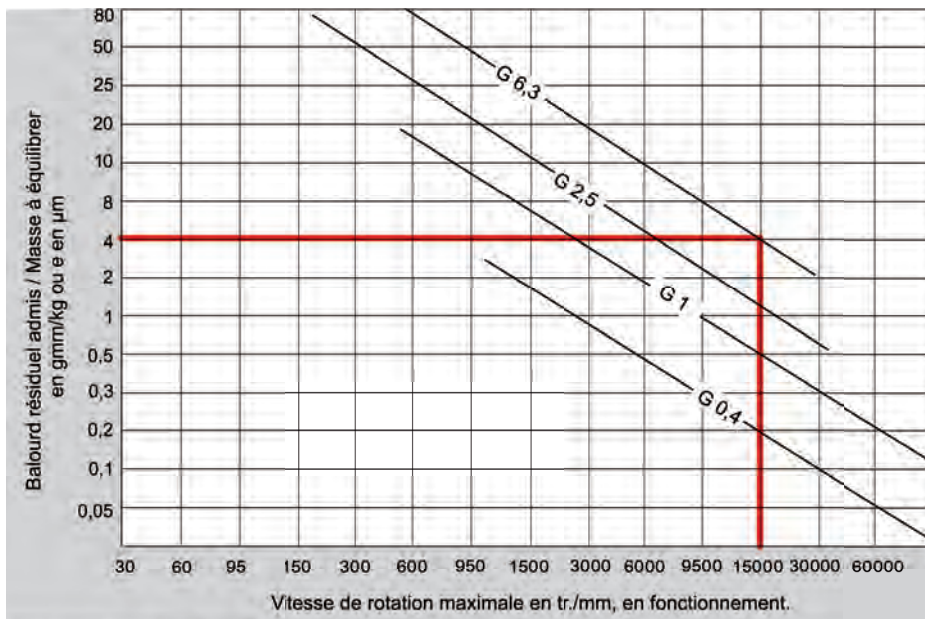

Les porte-outils KEMMLER sont équilibrés selon G 6,3 / 15.000 tr./mn.

Équilibré fin par perçages d'équilibrage dans la rainure



Pré-équilibré par perçages d'équilibrage à la colerette

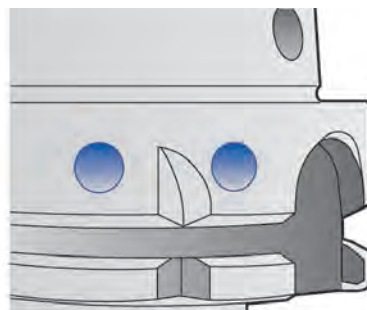

Pré-équilibré par face d'équilibrage aux corps d'outil





Les procédés d'usinages modernes exigent des attachements d'outils extrêmement performants. Les mandrins expansibles hydrauliques, rigides et précis, répondent à ces exigences.

Lorsque vous vissez la vis de serrage du mandrin, la pression du circuit hydraulique augmente jusqu'à déformation plastique de la membrane de serrage au niveau de la chambre hyperbare. Non seulement l'outil est fortement serré mais il est concentrique, pour ainsi dire, sans erreur de battement. La résistance au couple est invraisemblable. Si, pour le serrage de vos outils, vous utilisez des douilles de réduction de différents diamètres, vous profitez encore plus de vos mandrins hydrauliques. Si vous n'utilisez pas de douilles de serrage, il faut veiller à la profondeur minimale d'enforcement des attachements dans le mandrin!

Avantages

- Serrage d'outils très précis avec une erreur de battement de 3 µm max.
- Résistance au couple inégalée, grâce au système optimisé de la membrane de serrage spécialement conçu pour un serrage puissant
- Approprié aux usinages UGV et UTGV puisque sans segments de serrage et sans forces centrifuges
- Très bon état de surface et précision d'usinage grâce aux excellentes propriétés de la concentricité
- Echange d'outils rapide grâce au serrage facile de la vis de serrage
- Durée de vie des outils, augmentée
- Eventuelles vibrations absorbées par le circuit hydraulique avec effet d'amortisseur.

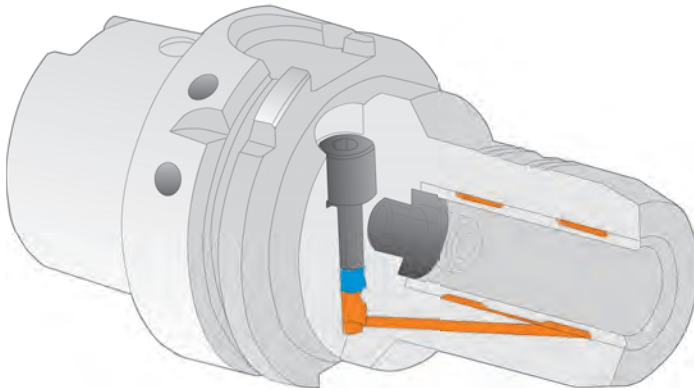

Serrage des attachements d'outils selon la norme DIN 6535 dans les mandrins expansibles hydrauliques

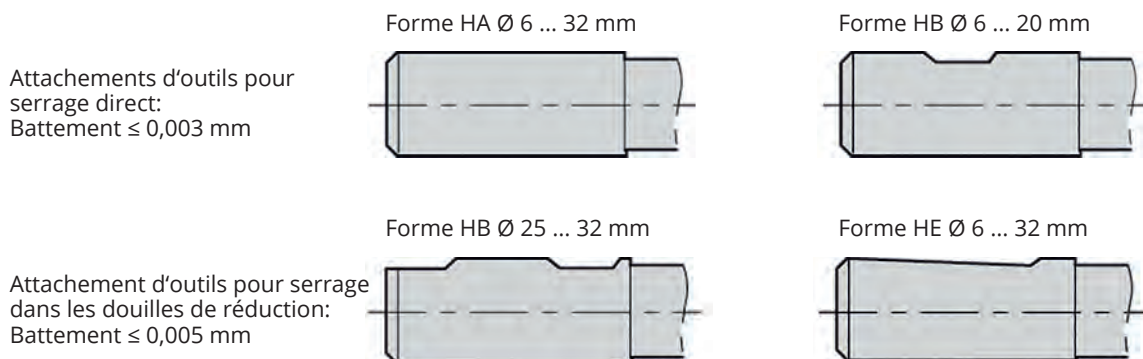



Pour garantir une fonctionnalité sans défauts du mandrin expansible hydraulique, veuillez respecter les instructions suivant:

Ne serrez que des queues d'outils selon DIN 1835 et DIN 6535 forme (HA) et B (HB) jusqu'au diamètre Ø 20 mm de queue de serrage avec une tolérance h_6 , rectifié précisément $Ra_{min} = 0,3$.

Queues d'outils selon DIN 6535 forme HE (Whistle Notch) il faut seulement utiliser avec des douilles de réduction. Tous mandrins expansibles hydrauliques sont pré-équilibrés de principe à G 6,3 15.000 tr/min.

Serrage et desserrage d'un outil

1. Nettoyez l'ouverture de réception et de la queue d'outil. Insérez l'outil jusqu'à la butée. Veuillez respecter la profondeur d'insertion et la course de réglage.
2. Serrez la queue en tournant la vis de serrage avec le clé hexagonale en sens horaire jusqu'à la butée. L'outil est serré. Un serrage vide peut endommager le porte-outil.
3. Pour desserrer l'outil il faut tourner la vis de serrage 5 à 6 fois contre le sens horaire et ensuite enlever l'outil.

Veuillez noter : Jamais serrer sans un outil serré !

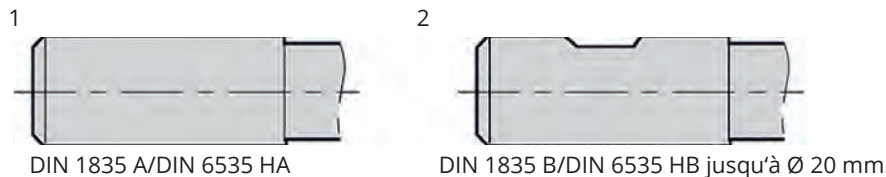

Nettoyage

Veillez à la propreté de l'ouverture de réception et de la queue d'outil.

Température

Plage de température optimale située entre 10–50°C. Ne pas employer pour des températures situées au delà 80°C.

Stockage

Stocker le mandrin expansible hydraulique en état non serré, nettoyé et légèrement huilé.

Queues de serrage

Ne serrez que des queues d'outil répondant aux normes DIN 1835 forme A et forme B (jusqu'à 20 mm).

Couple de serrage

Ø de serrage en mm	Couple (Nm)	Tolérance de queue d'outil
6	10	h_6
8	10	h_6
10	10	h_6
12	10	h_6
14	10	h_6
16	10	h_6
18	10	h_6
20	10	h_6
25	10	h_6
32	10	h_6



K Couples pour le serrage du fraises Weldon dans porte-fraises DIN 6359



Haute précision de la concentricité avec couples définis pour queues Weldon:



Couples pour DIN 1835

Perçage	Vis		Couple
Ø 6 mm	M 6	SW 3	10 Nm
Ø 8 mm	M 8	SW 4	10 Nm
Ø 10 mm	M 10	SW 5	16 Nm
Ø 12 mm	M 12	SW 6	28 Nm
Ø 14 mm	M 12	SW 6	28 Nm
Ø 16 mm	M 14	SW 6	42 Nm
Ø 18 mm	M 14	SW 6	42 Nm
Ø 20 mm	M 16	SW 8	50 Nm
Ø 25 mm	M 18 × 2	SW 10	60 Nm
Ø 32 mm	M 20 × 2	SW 10	72 Nm
Ø 40 mm	M 20 × 2	SW 10	72 Nm
Ø 50 mm	M 24 × 2	SW 12	90 Nm
Ø 63 mm	M 24 × 2	SW 12	90 Nm



Serrage et desserrage de l'outil

Pour travailler au maximum des possibilités de votre mandrin de perçage 08/ 13/ 16, veuillez s'il vous plaît suivre les instructions suivantes :

Attention :

L'outil ne peut être serré que hors de la machine ou broche arrêtée.

Le mandrin de perçage (Pos. 1) est serré sur le côté à l'aide d'un clé six pans (Pos. 3). Tournez la vis dans le sens horaire pour serrer, dans le sens anti-horaire pour desserrer.

1^{ère} étape

Ouvrez les mors du mandrin de perçage de façon suffisante à y loger l'outil (Pos. 2).

2^{ème} étape

L'outil (Pos. 2) doit être rentré dans le mandrin de perçage jusqu'à la butée, de façon à ce que la queue de l'outil puisse être serrée sur sa longueur maximale (Pos. 1). (Image 1)

3^{ème} étape

A l'aide de la clé six pans (Pos. 3), tournez la vis de serrage dans le sens horaire avec le couple de serrage adapté avec 15 Nm (pour Ø 0,5-8 avec 10 Nm) pour bloquer l'outil dans le mandrin de perçage.

Attention :

Ne pas utiliser de rallonge ou moyen de serrage non adapté. Lors d'utilisation d'un couple de serrage plus de 15 Nm (Ø 0,5-8 avec 10 Nm), le mandrin de serrage peut être endommagé. Le petit trou sur le cône est ce point de rupture intentionnellement prévu pour ne pas endommager davantage le mandrin de perçage.

4^{ème} étape

Assurez-vous après le serrage que l'outil est bien serré dans le mandrin de perçage.

Attention :

Ne pas serrer d'outil à queue conique, danger d'accident !

5^{ème} étape

Le mandrin de perçage est prêt à l'emploi et peut être introduit dans la broche de la machine (Image 3).

6^{ème} étape

Pour enlever l'outil, tournez la clé six pans dans le sens anti-horaire et sortez-le.

Réparation

En cas de réparation, veuillez retourner le mandrin de perçage. Nous échangeons par défaut la tête de perçage.

Comme ça vous recevrez un remplacement vite et le fonctionnement et la concentricité de <0,03 mm peuvent être garantis.



Image 1



Image 2

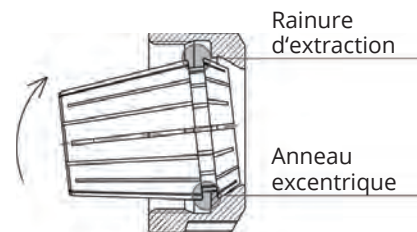

Image 3



Montage:

Positionner la rainure d'extraction de la pince dans l'anneau excentrique de l'écrou, puis basculer la pince jusqu'à l'enclenchement. Introduire l'outil. Visser l'écrou avec la pince sur le porte-outil. Nous recommandons de serrer l'écrou à l'aide d'un clé de serrage.



Démontage :

Après démontage du porte-outil, repoussez la pince comme illustré et dégagez-la de l'écrou en exerçant une pression latérale sur la partie arrière.

Une mauvaise utilisation nuit à la concentricité de la pince et peut endommager l'écrou.

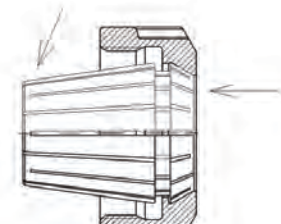

Attention :

Ne visser l'écrou que si la pince est enclenchée correctement.

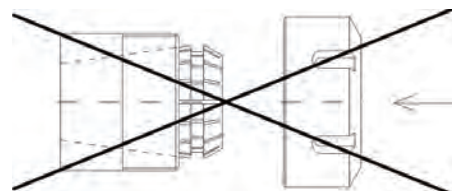

Ne jamais serrer des queues surdimensionnées!

Par exemple: ne forcer pas une pince Ø 12-11 mm pour serrer un dia. de queue de 12,2 mm, mais utiliser le dia. supérieur soit Ø 13-12 mm.



Dans la mesure du possible, serrer la queue de l'outil sur toute la longueur portante de la pince (au moins 2/3 de celle-ci).



Couple maximum

ER 16	M22 × 1,5	50 Nm
ER 20	M25 × 1,5	75 Nm
ER 25	M32 × 1,5	85 Nm
ER 32	M40 × 1,5	105 Nm
ER 40	M50 × 1,5	150 Nm

ER 11 Mini	M13 × 0,75	18 Nm
ER 16 Mini	M19 × 1	28 Nm

Veuillez noter le couple maximum indiqué dans le tableau!

Montage:

Insérez le petit diamètre du joint dans le centre d'écrou et augmentez la pression constamment jusqu'au joint enclenche. Le joint doit être au ras de la face extérieure de l'écrou.

Demontage:

Pour enlever le joint il faut pousser constamment à l'extérieur du joint jusqu'il éjecte.

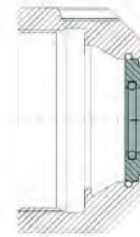
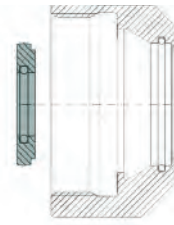

Bezeichnung Designation Désignation	E	EP	EA	EC	ECC	EH	ESP	G	GA	GC
Rundlauf Concentricity Concentricité	≤ 15 μ	≤ 5 μ	≤ 15 μ	≤ 15 μ	≤ 15 μ	≤ 15 μ	≤ 5 μ	≤ 15 μ	≤ 15 μ	≤ 15 μ
Spanndurchmesserüberbrückung Collapse Plage de serrage	0,5-1 mm	0,5-1 mm	h8	h8	h8	h8	h8	h8	h8	h8
Rostfrei Stainless Inoxydable	-	-	-	-	-	-	X	-	-	-
Abdichtung für IK (Innenkühlung) Sealing for IC (inner coolant supply) Avec joint d'étanchéité pour AC	-	-	X	-	-	X	-	-	X	-
Kühlkanalbohrung für IK (Innenkühlung) Jet holes for Inner Coolant Supply Avec canaux d'arrosage au centre	-	-	-	X	X	-	-	-	-	X
Innenvierkant für Gewindebohrer For tapping with internal square drive Pour taraudage avec carré d'entraînement	-	-	-	-	-	-	-	X	X	X



Le procédé de taraudage est un équilibre complexe entre des mouvements de rotation et axiaux de l'outil. Il est parfois nécessaire de réduire les mouvements axiaux de l'outil.

Si le mouvement axial n'est pas contrôlé précisément, le bord d'attaque et flanc arrière du taraud peuvent être forcés et peuvent progressivement « aplanir » le flanc du filetage, produisant ainsi un filet fin et surcôté.

Tension – La capacité de flottement parallèle à l'axe en traction permet au taraud de progresser dans l'élément sans interférence de l'avance axiale de la broche de la machine.



Compression – La capacité de flottement parallèle à l'axe en compression agit comme un tampon et permet au taraud de démarrer le travail à sa propre avance axiale indépendamment de l'axe de la machine.



Compression/Tension – Le flottement parallèle à l'axe inverse toute force extérieure pendant l'opération d'usinage.



Flottement radial – s'utilise lors d'un mauvais alignement léger de l'axe de la machine avec l'axe du trou.





Pour un emploi correct de l'appareil, vérifier par un contrôle visuel sur le premier filetage de ne pas dépasser les valeurs de compensation en compression et extension. Ceci pour éviter d'abîmer le filetage ou d'endommager l'appareil à tarauder.

Sur ce tarauder existe le dispositif de desaccouplement du porte taraud par l'opérateur à fin compensation en extension.

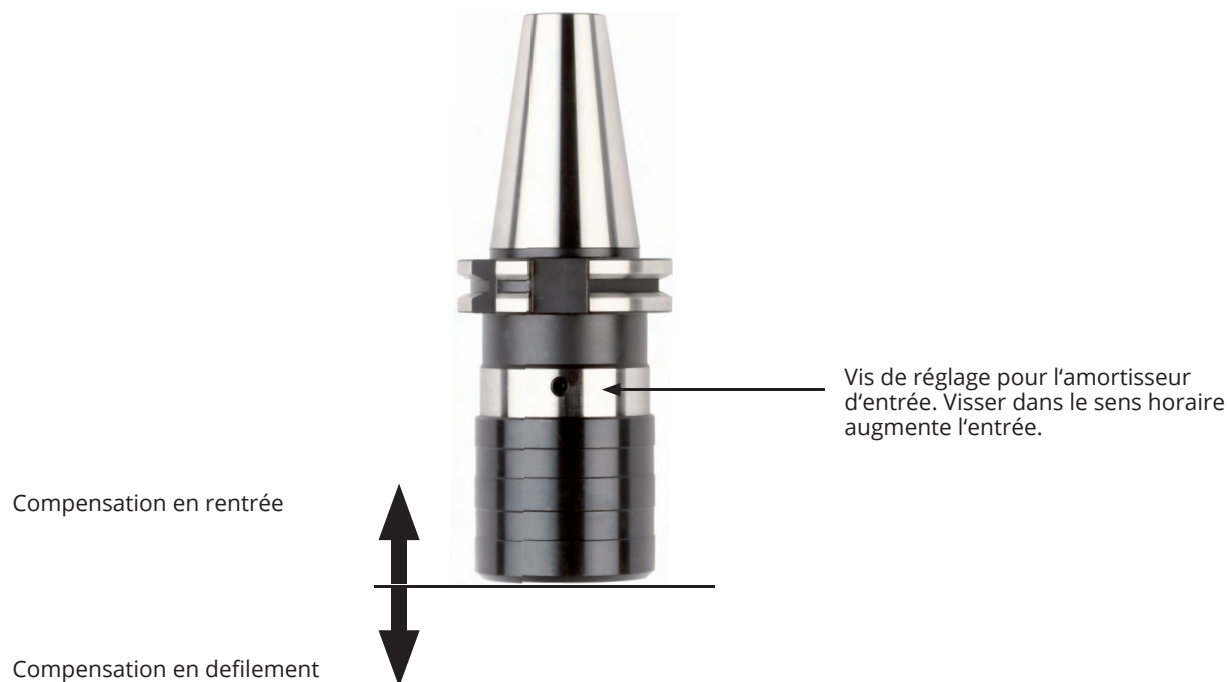

Réf.	Capacité de taraudage	Douille	Compensation	
			Rentrée	Defilement
xxx.16.12	M 3-M14	16.11.xx / 16.01.xx	7	7
xxx.16.20	M 5-M22	16.12.xx / 16.02.xx	12	12
xxx.16.36	M14-M36	16.14.xx / 16.03.xx	17,5	17,5



Diamètre de la queue					
Ø × □	DIN 352	DIN 5157	DIN 371	DIN 374	DIN 376
Ø 2,5 × 2,1 □	M1		M1	M3	M3,5
Ø 2,5 × 2,1 □	M1,1		M1,1	M3,5	
Ø 2,5 × 2,1 □	M1,2		M1,2		
Ø 2,5 × 2,1 □	M1,4		M1,4		
Ø 2,5 × 2,1 □	M1,6		M1,6		
Ø 2,5 × 2,1 □	M1,8		M1,8		
Ø 2,8 × 2,1 □	M2		M2	M4	M4
Ø 2,8 × 2,1 □	M2,2		M2,2		
Ø 2,8 × 2,1 □	M2,5		M2,5		
Ø 3,5 × 2,7 □	M3		M3	M5	M5
Ø 4 × 3 □	M3,5		M3,5		
Ø 4,5 × 3,4 □	M4		M4	M6	M6
Ø 6 × 4,9 □	M5		M5		
Ø 6 × 4,9 □	M6		M6		
Ø 6 × 4,9 □	M8			M8	M8
Ø 7 × 5,5 □	M10	G 1/8"		M10	M10
Ø 8 × 6,2 □			M8		
Ø 9 × 7 □	M12			M12	M12
Ø 10 × 8 □			M10		
Ø 11 × 9 □	M14	G 1/4"		M14	M14
Ø 12 × 9 □	M16	G 3/8"		M16	M16
Ø 14 × 11 □	M18			M18	M18
Ø 16 × 12 □	M20	G 1/2"		M20	M20
Ø 18 × 14,5 □	M22	G 5/8"		M22	M22
Ø 18 × 14,5 □	M24			M24	M24
Ø 20 × 16 □	M27	G 3/4"		M27	M27
Ø 22 × 18 □	M30	G 7/8"		M30	M30
Ø 25 × 20 □	M33	G 1		M33	M33
Ø 28 × 22 □	M36	G 1 1/8"		M36	M36
Ø 32 × 34 □	M39	G 1 1/4"		M39	M39
Ø 32 × 24 □	M42			M42	M42
Ø 36 × 29 □	M45	G 1 3/8"		M45	M45
Ø 36 × 29 □	M48	G 1 1/2"		M48	M48
Ø 36 × 29 □		G 1 3/4"			
Ø 36 × 29 □		G 2"			

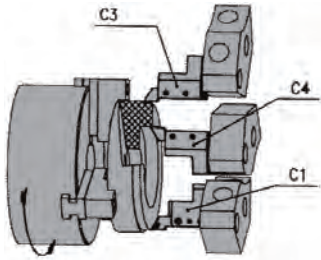

Utilisation d'attachements radiaux avec la broche en sens anti-horaire

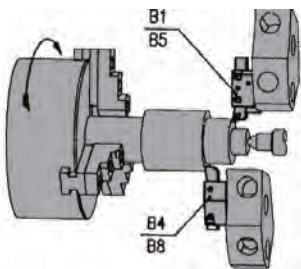

Utilisation d'attachements radiaux avec la broche en sens horaire

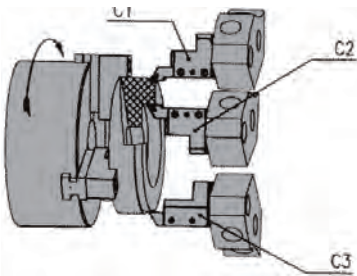

Utilisation d'attachements axiaux avec la broche en sens anti-horaire

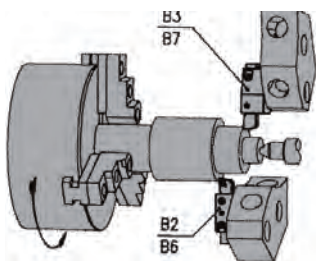

Utilisation d'attachements axiaux avec la broche en sens anti-horaire



Le mandrin à pinces de précision système KPS est l'alternative aux mandrins expansibles hydrauliques et mandrins de frettage.

Haute flexibilité par pinces interchangeable (pinces de précision système KPS disponible de Ø 0,5 jusqu'à 16 mm).

Forces de serrage et concentricité élevés résultent en surfaces précises et une durée de vie pour l'outil prolongée.

Ecrou de serrage lisse sans rainures pour usinage à très grande vitesse.

Version effilée.



Queue d'outil :

Cylindrique DIN 1835-1 forme A/DIN 6535 forme HA, tolérance h_8 .

Serrage au diamètre nominal. Pinces par capacité de 0,5 mm.

Faux rond :

Le faux-rond maximum mesuré sur pigne à 4×d par rapport au cône extérieur est de 5 µm.

Angle d'inclinaison:

L'angle d'inclinaison de la face de serrage est à 4°, ainsi il n'y a pas de forces radiales pendant le serrage qui peuvent influencer la concentricité.



Equilibrage :

Équilibré fin de principe (G 2,5 30.000 tr/min.).

Observation:

Mandrins à pinces système KPS sont fournis sans vis-butées par défaut, parce qu'ils ne sont pas recommandés à grandes vitesses.

Taille du mandrin à pince	Capacité d mm	Ø pas en mm	Couple de serrage max.	Système de serrage Type D, tr/mn max.*
D16 (KPS 10)	0,5 - 10	0,5	40 Nm	60.000
D24 (KPS 16)	1,0 - 16	0,5	70 Nm	40.000

* La vitesse de rotation maximum pour ce modèle de porte-outil est souvent restreinte par le type et la taille du cône.

Couple statique transmissible à la queue d'outil (Nm)

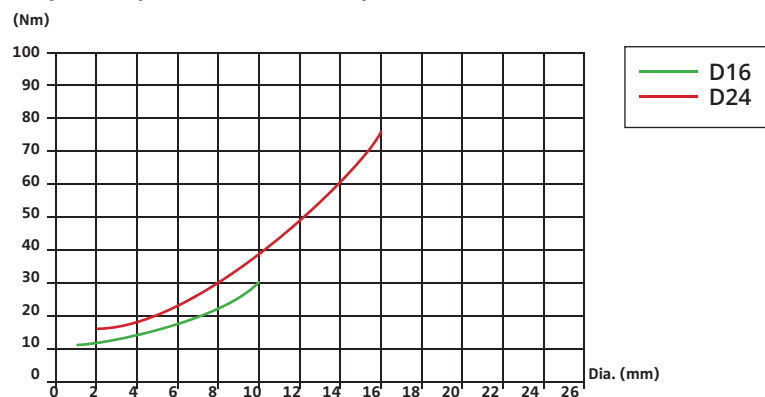

Recommandations d'assemblage pour les pinces système KPS avec la bague de montage

1. Dévisser l'écrou du mandrin à pince.
2. Insérer et compresser la pince dans la bague de montage.*
3. Introduire l'ensemble pince et bague dans l'écrou jusqu'en butée.
4. Pousser sur l'arrière de la pince pour éjecter l'ensemble pince et écrou de la bague.



Demontage

Insérer la pince avec l'écrou dans le moyen d'assemblage pour pousser la pince.
Ensuite enlever l'écrou.



Pinces de serrage



Moyen d'assemblage



Écrous de serrage*



Clés de serrage*

* breveté



Les mandrins de serrage à haute performance conviennent pour presque toutes les applications. Particulier en cas d'enlèvement de copeaux lourd nous garantissons forces de serrage élevées incomparables et grande fiabilité des processus.

Mandrins de serrage HKS conduisent par la rigidité de l'alimentation, la concentricité et de serrage, même à 3 mm du revêtement de nez à la finition de surface exceptionnelle et basse durée de vie.

Tous les mandrins de serrage HKS accordent le faux-rond maximum mesuré sur pige à 3x d par rapport au cône extérieur est de 3 µm.

Application:

- Enlèvement de copeaux lourd
- Fraisage finisseuse
- Fraisage dur
- Perçage, Frottage
- Filetage

Faux rond :

Le faux-rond maximum mesuré sur pige à 3x d par rapport au cône extérieur est de 3 µm.

Equilibrage :

Équilibré fin de principe (G 6,3 15.000 min⁻¹).

Queue d'outil :

Tous les queues d'outils disponibles dans le commerce, avec ou sans queue Weldon peuvent être fixés directement ou avec un manchon de serrage.



Taille	20mm	25mm	32mm
Couple	50-70 Nm	80-100 Nm	80-100 Nm
Tension	780 Nm	2000 Nm	2000 Nm





RELEASE THE BEAST



KEMMLER

K KEMMLER[®]
Präzisionswerkzeuge



Exemple:

40 3 . 02 . 20 .1

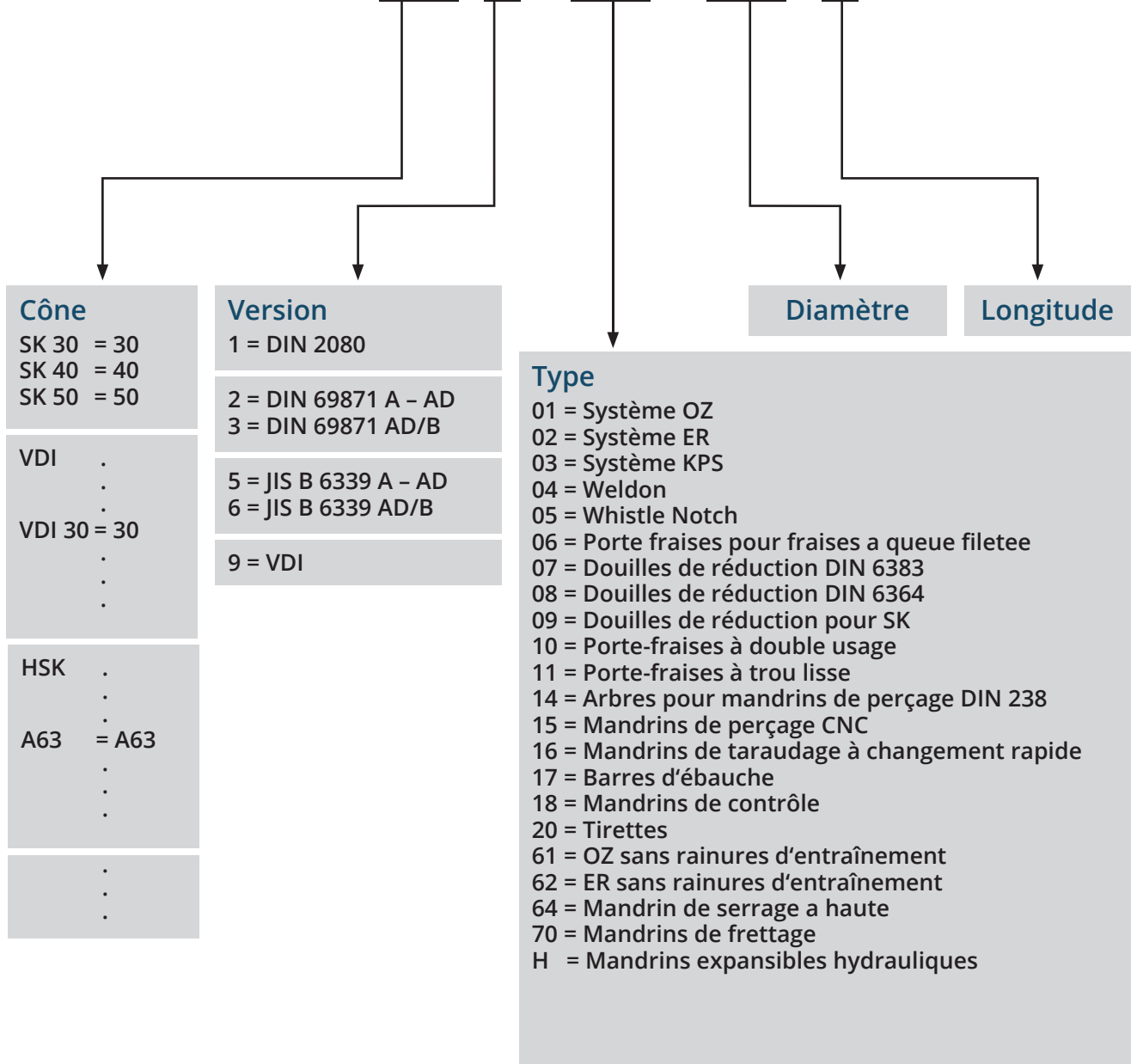

KEMMLER OEM

Laserbeschriftung der Werkzeuge

Laser engraving of toolholders

Marquage de porte-outils avec laser



Laserbeschriftung von Werkzeugaufnahmen

Durch unsere Laserbeschriftungsanlagen können wir Ihnen individuelle, kostengünstige Laserbeschriftung der Werkzeuge anbieten. Die dauerhafte Beschriftung kann mit Ihrem Firmennamen, Firmenlogo oder mit sonstigen Sonderzeichen erfolgen. Ebenfalls können die Etiketten auf den Verpackungen nach Ihren Vorgaben gestaltet werden.

Laser engraving of toolholders

With our newly acquired laser engravers we can offer you individual and cost-effective engraving of tools. The permanent engraving can include your company's name, logo or any other special description. Also the labels on the packaging can be designed according to your specifications.

Marquage laser de porte-outils

A l'aide de notre dispositif de marquage avec laser on peut mettre sur vos porte-outils telles données individuelles que par exemple le nom ou le logo de votre société pour le prix raisonnable. En outre selon vos besoins notre équipe peut rajouter des étiquettes sur les emballages avec l'information souhaitée.





Notes
Notes





Notes
Notes





Notes
Notes





Ihr Weg zu uns · How to find us · Plan d'accès

Mössingen befindet sich im Bundesland Baden-Württemberg, ca. 50 km südlich von Stuttgart.

Mössingen is situated in the federal state of Baden-Württemberg, approximately 50 km south of Stuttgart.

Mössingen se trouve dans la province Baden-Württemberg, à peu près 50 km au sud de Stuttgart.

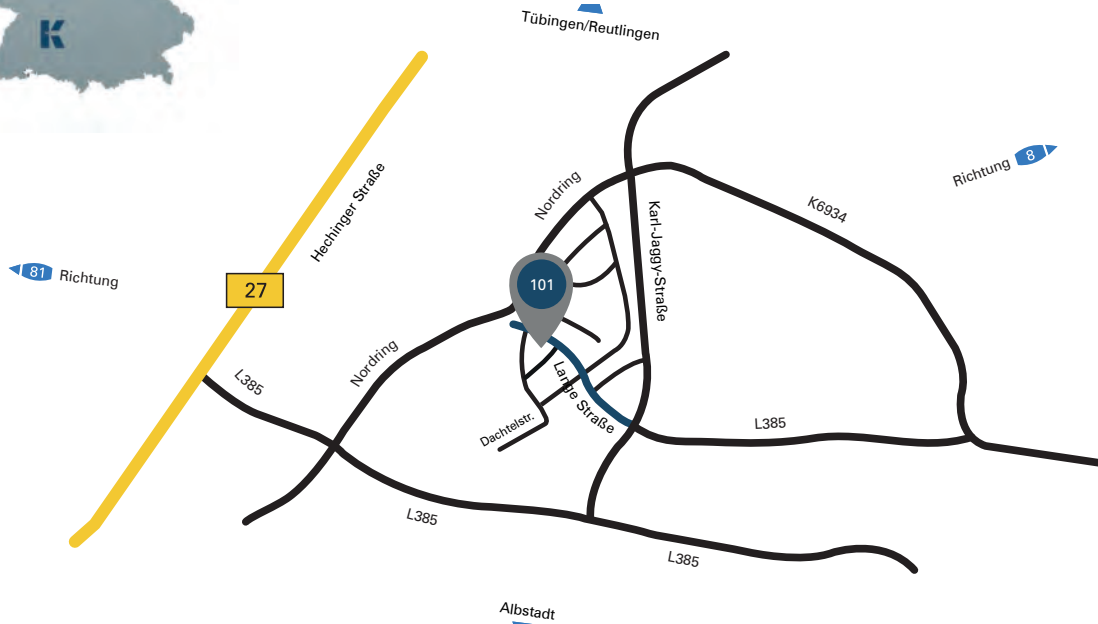

KEMMLER Präzisionswerkzeuge GmbH
Lange Str. 101
72116 Mössingen
Deutschland

Telefon: +49 7473 92408-0
Telefax: +49 7473 92408-20

info@kemmler-tools.de
www.kemmler-tools.de
facebook.com/kemmler





Copyright © 2019 Kemmler Präzisionswerkzeuge GmbH. Alle Rechte vorbehalten.
First Class® ist eine eingetragene Marke der Kemmler Präzisionswerkzeuge GmbH.
Technische Änderungen und Änderungen des Lieferprogramms vorbehalten. Für Druckfehler und Irrtümer keine Gewähr.

Printed in Germany 2019.
Dokumentnummer: 19-364289

Für sämtliche Leistungen gelten unsere jeweils aktuellen Allgemeinen Geschäftsbedingungen, die Sie auch im Internet unter www.kemmler-tools.de einsehen können.

*Copyright © 2019 Kemmler Präzisionswerkzeuge GmbH. All rights reserved.
First Class® is a registered trademark of the Kemmler Präzisionswerkzeuge GmbH.*

Subject to technical changes. No responsibility for errors and printing errors are accepted.

*Printed in Germany 2019.
Document number: 19-364289*

Our terms and conditions apply to all services offered by Kemmler. Please find a current version of our terms and conditions on the internet at: www.kemmler-tools.de

Copyright © 2019 Kemmler Präzisionswerkzeuge GmbH. Tous droits réservés.
First Class® est une marque déposée de la Kemmler Präzisionswerkzeuge GmbH.

Nous nous réservons le droit de procéder à des modifications.
Les erreurs de frappe ou d'impression n'engagent pas notre responsabilité.

Imprimé en Allemagne 2019.
Numéro du document: 19-364289

Nos conditions générales actuelles, qui peut être consulté sur le site Internet www.kemmler-tools.de s'appliquent à tous les services.



KEMMLER
Präzisionswerkzeuge GmbH
Lange Str. 101
DE - 72116 Mössingen
Telefon: +49 7473 92408-0
Telefax: +49 7473 92408-20
info@kemmler-tools.de
www.kemmler-tools.de
facebook.com/kemmler

Ihr Fachhändler - Your specialist dealer - Votre spécialiste



www.kemmler-tools.de



facebook.com/kemmler